

AFCT-5179xZ

SC Duplex Single Mode Transceiver



Data Sheet



Description

The AFCT-5179xZ transceiver is a high performance, cost effective module for serial optical data communications applications specified for a signal rate of 125 MBd. It is designed for Fast Ethernet applications and is also compatible with EFM baseline 100BASE-LX10 standard over dual single mode fiber.

This module is designed for single mode fiber and operates at a nominal wavelength of 1300 nm. It incorporates Avago Technologies' high performance, reliable, long wavelength optical devices and proven circuit technology to give long life and consistent service.

The transmitter section uses a Multiple Quantum Well laser with full IEC 825 and CDRH Class I eye safety.

The receiver section uses a planar PIN photodetector for low dark current and excellent responsivity.

A pseudo-ECL logic interface simplifies interface to external circuitry.

Features

- SC duplex single mode transceiver
- Single +3.3V or +5V power supply
- Multisourced 1 x 9 pin configuration
- Manufactured in an ISO9001 certified factory
- Aqueous washable plastic package
- Interchangeable with LED multisourced 1 x 9 transceivers
- Unconditionally eye safe laser IEC 825/CDRH Class 1 compliant
- Designed for EFM (Ethernet in the First Mile) baseline 100Base-LX10 performance over dual single mode fiber
- RoHS compliant
- Two temperature ranges:
 - 0 °C to +70 °C, AFCT-5179BZ/DZ
 - 40 °C to +85 °C, AFCT-5179AZ/CZ

Applications

- Fast Ethernet
- Ethernet in the First Mile

Connection Diagram

RECEIVER SIGNAL GROUND	o 1	○
RECEIVER DATA OUT	o 2	N/C
RECEIVER DATA OUT BAR	o 3	
SIGNAL DETECT	o 4	
RECEIVER POWER SUPPLY	o 5	
TRANSMITTER POWER SUPPLY	o 6	
TRANSMITTER DATA IN BAR	o 7	
TRANSMITTER DATA IN	o 8	N/C
TRANSMITTER SIGNAL GROUND	o 9	○

Top View

Pin Descriptions:

Pin 1 Receiver Signal Ground V_{EER} :

Directly connect this pin to the receiver ground plane.

Pin 2 Receiver Data Out RD:

See recommended circuit schematic, Figure 4.

Pin 3 Receiver Data Out Bar RD:

See recommended circuit schematic, Figure 4.

Pin 4 Signal Detect SD:

Normal optical input levels to the receiver result in a logic "1" output.

Low optical input levels to the receiver result in a fault condition indicated by a logic "0" output.

This Signal Detect output can be used to drive a PECL input on an upstream circuit, such as Signal Detect input or Loss of Signal-bar.

Pin 5 Receiver Power Supply V_{CCR} :

Provide +3.3 V or +5 V dc via the recommended transmitter power supply filter circuit. Locate the power supply filter circuit as close as possible to the V_{CC} pin.

Pin 6 Transmitter Power Supply V_{CCR} :

Provide +3.3 V or +5 V dc via the recommended transmitter power supply filter circuit. Locate the power supply filter circuit as close as possible to the V_{CC} pin.

Pin 7 Transmitter Data In Bar TD:

See recommended circuit schematic, Figure 4.

Pin 8 Transmitter Data In TD:

See recommended circuit schematic, Figure 4.

Pin 9 Transmitter Signal Ground V_{EET} :

Directly connect this pin to the transmitter ground plane.

Mounting Studs

The mounting studs are provided for mechanical attachment to the circuit board. They are embedded in the nonconductive plastic housing and are not tied to the transceiver internal circuit and should be soldered into plated-through holes on the printed circuit board.

Functional Description

Receiver Section

Design

The receiver section contains an InGaAs/InP photo detector and a preamplifier within the receptacle, coupled to a postamplifier/decision circuit on a separate circuit board.

The postamplifier is ac coupled to the preamplifier as illustrated in Figure 1. The coupling capacitor is large enough to pass the EFM test pattern at 125 MBd without significant distortion or performance penalty.

Figure 1 also shows a filter network which limits the bandwidth of the preamp output signal. The filter is designed to bandlimit the preamp output noise and thus improve the receiver sensitivity.

These components will also reduce the sensitivity of the receiver as the signal bit rate is increased above 155 MBd.

Noise Immunity

The receiver includes internal circuit components to filter power supply noise. Under some conditions of EMI and power supply noise, external power supply filtering may be necessary. If receiver sensitivity is found to be degraded by power supply noise, the filter network illustrated in Figure 2 may be used to improve performance. The values of the filter components are general recommendations and may be changed to suit a particular system environment. Shielded inductors are recommended.

Terminating the Outputs

The PECL Data outputs of the receiver may be terminated with the standard Thevenin-equivalent 50 ohm to $V_{CC} - 2V$ termination.

Other standard PECL terminating techniques may be used.

The two outputs of the receiver should be terminated with identical load circuits to avoid unnecessarily large ac current in V_{CC} . If the outputs are loaded identically the ac current is largely nulled. The Signal Detect output of the receiver is PECL logic and must be loaded if it is to be used. The Signal Detect circuit is much slower than the data path, so the ac noise generated by an asymmetrical load is negligible. Power consumption may be reduced by using a higher than normal load impedance for the Signal Detect output. Transmission line effects are not generally a problem as the switching rate is slow.

The Signal Detect Circuit

The Signal Detect circuit works by sensing the peak level of the received signal and comparing this level to a reference.

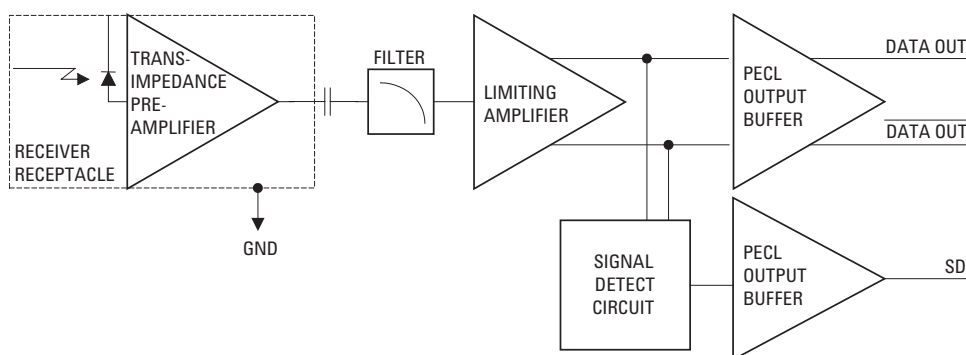

Figure 1 - Receiver Block Diagram

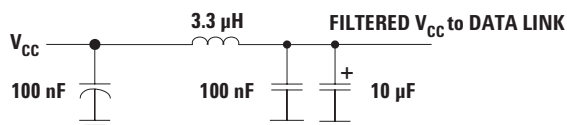

Figure 2 - p Filter Network for Noise Filtering

Transmitter Section

Design

The transmitter section, Figure 3, uses a Multiple Quantum Well laser as its optical source. The package of this laser is designed to allow repeatable coupling into single mode fiber. In addition, this package has been designed to be compliant with IEC 825 Class 1 and CDRH Class I eye safety requirements. The optical output is controlled by a custom IC which detects the laser output via the monitor photodiode. This IC provides both dc and ac current drive to the laser to ensure correct modulation, eye diagram and extinction ratio over temperature, supply voltage and life.

PCB mounting

The AFCT-5179xZ has two solderable mounting studs, Figures 5 and 6. These studs are not electrically connected. The transceiver is designed for common production processes. It may be wave soldered and aqueous washed providing the process plug is in place.

Each process plug can only be used once during processing, although with subsequent use, it can be used as a dust cover.

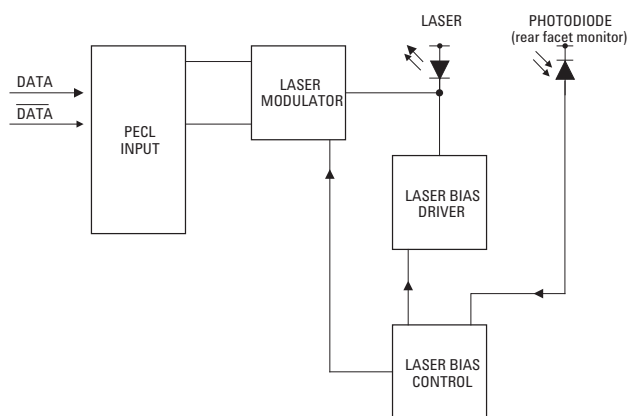
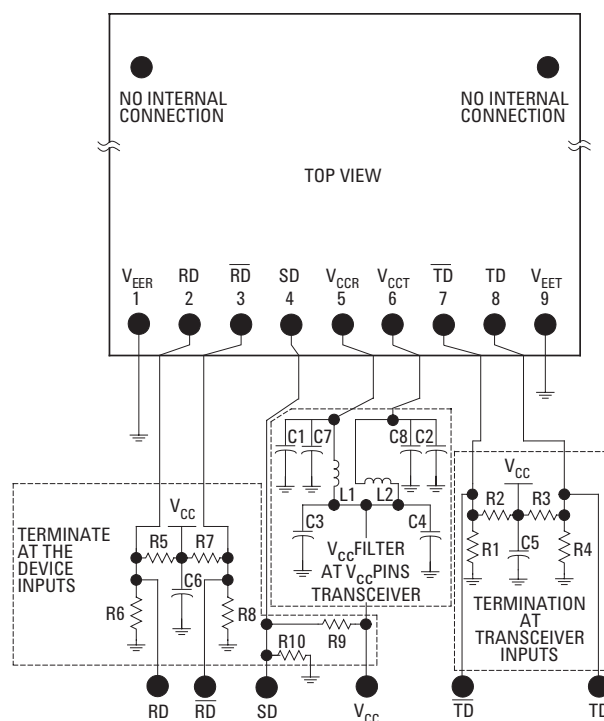

Figure 3 - Simplified Transmitter Schematic



- NOTES:
 THE SPLIT-LOAD TERMINATIONS FOR ECL SIGNALS NEED TO BE LOCATED AT THE INPUT OF DEVICES RECEIVING THOSE ECL SIGNALS. RECOMMEND 4-LAYER PRINTED CIRCUIT BOARD WITH 50Ω MICROSTRIP SIGNAL PATHS BE USED.
- R1 = R4 = R6 = R8 = R10 = 130 Ω
 - R2 = R3 = R5 = R7 = R9 = 82 Ω
 - C1 = C2 = 10 μF (see Figure 2)
 - C3 = C4 = C7 = C8 = 100 nF
 - C5 = C6 = 0.1 μF
 - L1 = L2 = 3.3 μH COIL OR FERRITE INDUCTOR.

Figure 4 - Recommended Circuit Schematic

Regulatory Compliance

Feature	Test Method	Performance
Electrostatic Discharge (ESD) to the Electrical Pins	MIL-STD-883F Method 3015.7	Class 1 (>1 kV) - Human Body Model
Electrostatic Discharge (ESD) to the Duplex SC Receptacle	Variation of IEC 801-2	Products of this type, typically, withstand at least 15 kV without damage when the Duplex SC Connector Receptacle is contacted by a Human Body Model probe.
Electromagnetic Interference (EMI)	FCC Class B CENELEC EN55022 Class B (CISPR 22A) VCCI Class 1	Typically provide a 17 dB margin to the noted standard limits up to 6 GHz, when tested in a GTEM cell with the transceiver mounted to a circuit card with a chassis enclosure.
Immunity	Variation of IEC 801-3	Typically show no measurable effect from a 10 V/m field swept from 27 MHz to 1 GHz applied to the transceiver without a chassis enclosure.
Eye Safety	FDA CDRH 21-CFR 1040 Class I	CDRH Accession Number: 9521220-121
	IEC 825 Issue 1 1993:11 Class 1 CENELEC EN60825 Class 1	TUV Bauart License: 933/21201880/10
Component Recognition	Underwriters Laboratories and Canadian Standards Association Joint Component Recognition for Information Technology Equipment Including Electrical	UL File#: E173874

Performance Specifications

Absolute Maximum Ratings

Stresses in excess of the absolute maximum ratings can cause catastrophic damage to the device. Limits apply to each parameter in isolation, all other parameters having values within the recommended operating conditions. It should not be assumed that limiting values of more than one parameter can be applied to the product at the same time. Exposure to the absolute maximum ratings for extended periods can adversely affect device reliability.

Parameter	Symbol	Minimum	Maximum	Units	Notes
Storage Temperature	T _S	-40	+85	°C	-
Operating Temperature - AFCT-5179BZ/DZ	-	0	+70	°C	1
Operating Temperature - AFCT-5179AZ/CZ	-	-40	+85	°C	1
Lead Soldering Temperature/Time	-	-	+260/10	°C/s	-
Output Current (other outputs)	I _{OUT}	0	30	mA	-
Input Voltage	-	GND	V _{CC}	V	-
Power Supply Voltage	-	0	+6	V	-

Operating Environment

Parameter	Symbol	Minimum	Maximum	Units	Notes
Power Supply Voltage	V _{CC}	+3.1	+5.25	V	-
Ambient Operating Temperature - AFCT-5179BZ/DZ	T _{OP}	0	+70	°C	1
Ambient Operating Temperature - AFCT-5179AZ/CZ	T _{OP}	-40	+85	°C	1

Transmitter Section

(Ambient Operating Temperature $V_{CC} = 3.1\text{ V to }5.25\text{ V}$)

Parameter	Symbol	Minimum	Typical	Maximum	Units	Notes
Output Center Wavelength	λ_C	1260	-	1360	nm	-
Output Spectral Width (RMS)	$\Delta\lambda$	-	-	7.7	nm	-
Average Optical Output Power	P_O	-15	-	-8	dBm	2
Extinction Ratio	E_R	6	-	-	dB	-
Power Supply Current	I_{CC}	-	50	140	mA	3
Output Eye	Compliant with eye mask IEEE Std 802.3ah- 2004					4
RIN	RIN_{12} (OMA)	-	-110	-	dB/Hz	-
Transmitter Dispersion Penalty	TDP	-	3.0	4	dB	-
Optical Return Loss	ORL	-	-	12	dB	-
Data Input Current - Low	I_{IL}	-350	-	-	μA	-
Data Input Current - High	I_{IH}	-	-	350	μA	-
Differential Input Voltage	$V_{IH} - V_{IL}$	300	-	-	mV	-
Data Input Voltage - Low	$V_{OL} - V_{CC}$	-2.0	-	-1.475	V	5
Data Input Voltage - High	$V_{OH} - V_{CC}$	-1.165	-	-0.74	V	5

Notes:

- 2 m/s air flow required.
- Output power is power coupled into a single mode fiber.
- The power supply current varies with temperature. Maximum current is specified at $V_{CC} = \text{Maximum @ maximum temperature}$ (not including terminations) and end of life.
- Mask coordinates (X1, X2, X3, Y1, Y2, Y3, Y4) = (0.18, 0.29, 0.35, 0.35, 0.38, 0.40, 0.55).
- These inputs are compatible with 10 K, 10 KH and 100 K ECL and PECL inputs.

Receiver Section

(Ambient Operating Temperature $V_{CC} = 3.1\text{ V to }5.25\text{ V}$)

Parameter	Symbol	Minimum	Typical	Maximum	Units	Notes
Receiver Sensitivity	-	-	-	-25	dBm	6a
	-	-	-	-31	dBm	6b
Maximum Input Power	-	-8	-	-	dBm	-
Signal Detect - Asserted	P_A	$P_D + 0.5$	-	-25	dBm avg.	-
Signal Detect - Deasserted	P_D	-45	-	-	dBm avg.	-
Signal Detect - Hysteresis AFCT-5179BZ/DZ	$P_A - P_D$	0.5	-	4.0	dB	-
	$P_A - P_D$	0.5	-	5.0	dB	-
Power Supply Current	I_{CC}	-	55	100	mA	7
Data Output Voltage - Low	$V_{OL} - V_{CC}$	-2.0	-	-1.50	V	8
Data Output Voltage - High	$V_{OH} - V_{CC}$	-1.1	-	-0.74	V	8
Signal Detect Output Voltage - Low	$V_{OL} - V_{CC}$	-2.0	-	-1.50	V	8
Signal Detect Output Voltage - High	$V_{OH} - V_{CC}$	-1.1	-	-0.74	V	8

Notes:

- 6a. Minimum sensitivity for IEEE 802.3ah test pattern with baseline wander.
- 6b. Minimum sensitivity and saturation levels for a FDDI test pattern as defined in FDDI SMF-PMDI with 4B/5B NRZI encoded data that contains a duty cycle baseline wander effect of 50kHz and a $2^{23}-1$ PRBS with 72 ones and 72 zeros inserted (ITU-T recommendation G.958).
- The current excludes the output load current.
- These outputs are compatible with 10 K, 10 KH and 100 K ECL and PECL outputs.

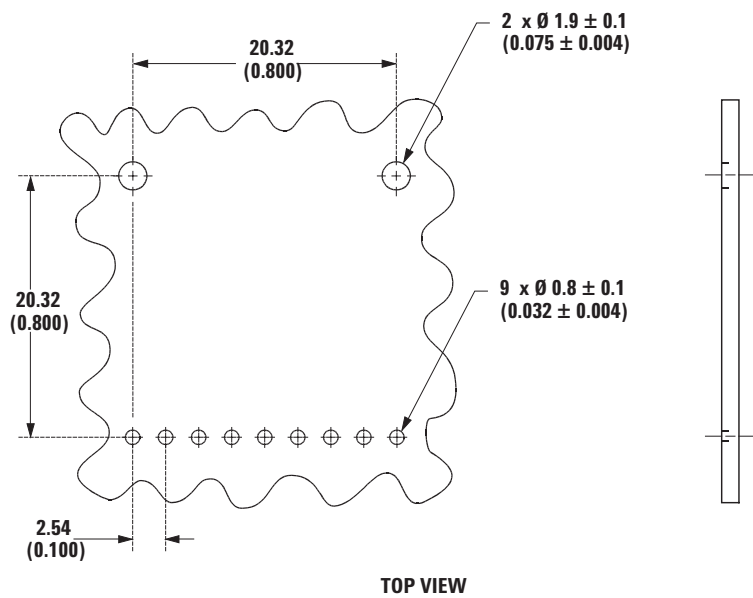

DIMENSIONS ARE IN MILLIMETERS (INCHES)

Figure 6. Recommended Board Layout Pattern

Ordering Information

Temperature Range 0 °C to +70 °C

AFCT-5179BZ Black Case
AFCT-5179DZ Blue Case

Temperature Range -40 °C to +85 °C

AFCT-5179AZ Black Case
AFCT-5179CZ Blue Case

Class 1 Laser Product: This product conforms to the applicable requirements of 21 CFR 1040 at the date of manufacture

Date of Manufacture: _____

Avago Technologies, No 1 Yishun Ave 7, Singapore

Handling Precautions

1. The AFCT-5179xZ can be damaged by current surges or overvoltage. Power supply transient precautions should be taken.
2. Normal handling precautions for electrostatic sensitive devices should be taken.

For product information and a complete list of distributors, please go to our web site: www.avagotech.com

Avago, Avago Technologies, and the A logo are trademarks of Avago Technologies, Pte. in the United States and other countries. Data subject to change. Copyright © 2006 Avago Technologies Pte. All rights reserved.
5989-2878EN - August 2, 2006

