

HFBR-53A5VEMZ/HFBR-53A5VMZ

3.3 V 1 x 9 Fiber Optic Transceivers for Gigabit Ethernet Low Voltage

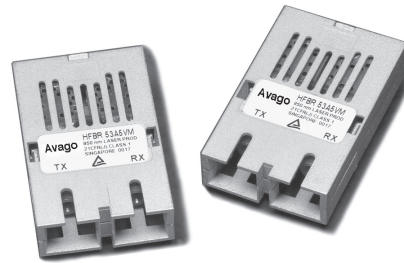

Data Sheet



Description

The HFBR-53A5VEMZ transceivers from Avago Technologies allow the system designer to implement a range of solutions for multimode Gigabit Ethernet applications.

The overall Avago transceiver product consists of three sections: the transmitter and receiver optical sub-assemblies, an electrical subassembly, and the package housing which incorporates a duplex SC connector receptacle.

Transmitter Section

The transmitter section of the HFBR-53A5VEMZ/FMZ consists of an 850 nm Vertical Cavity Surface Emitting Laser (VCSEL) in an optical subassembly (OSA), which mates to the fiber cable. The OSA is driven by a custom, silicon bipolar IC which converts differential PECL compatible logic signals into an analog laser diode drive current. The high speed output lines are internally ac-coupled and differentially terminate with a 100 Ω resistor.

Receiver Section

The receiver of the HFBR-53A5VEMZ/FMZ includes a GaAs PIN photo-diode mounted together with a custom, silicon bipolar transimpedance preamplifier IC in an OSA. This OSA is mated to a custom silicon bipolar circuit that provides post-amplification and quantization.

The post-amplifier also includes a Signal Detect circuit which provides a TTL logic-high output upon detection of a usable input optical signal level. The high speed output lines are internally ac-coupled.

Features

- Compliant with specifications for IEEE- 802.3z Gigabit Ethernet
- Industry standard mezzanine height 1 x 9 package style with integral duplex SC connector
- Performance HFBR-53A5VEMZ/FMZ:
 - 220 m links in 62.5/125 μ m MMF 160 MHz* km cables
 - 275 m links in 62.5/125 μ m MMF 200 MHz* km cables
 - 500 m links in 50/125 μ m MMF 400 MHz* km cables
 - 550 m links in 50/125 μ m MMF 500 MHz* km cables
- IEC 60825-1 Class 1/CDRH Class I laser eye safe
- Single +3.3 V power supply operation with PECL compatible logic interfaces and TTL Signal Detect
- Wave solder and aqueous wash process compatible
- RoHS compliant

Applications

- Switch to switch interface
- Switched backbone applications
- High speed interface for file servers
- High performance desktops

Related Products

- Physical layer ICs available for optical or copper interface (HDMP-1636A/1646A)
- Quad Serdes IC available for high-density interface
- Versions of this transceiver module also available for +5 V operation (AFBR-53D5XZ/HFCT-53D5XXZ)
- MT-RJ SFF fiber optic transceivers for Gigabit Ethernet (HFBR/HFCT-5912EZ)
- Gigabit Interface Converters (GBIC) Gigabit Ethernet SX-AFBR-5601Z/LX-AFCT-5611Z

Package and Handling Instructions

Flammability

The HFBR-53A5VEMZ/FMZ transceiver housing is made of high strength, heat resistant, chemically resistant, and UL 94V-0 flame retardant plastic.

Recommended Solder and Wash Process

The HFBR-53A5VEMZ/FMZ is compatible with industry-standard wave or hand solder processes.

Process Plug

This transceiver is supplied with a process plug (HFBR-5000) for protection of the optical ports within the duplex SC connector receptacle. This process plug prevents contamination during wave solder and aqueous rinse as well as during handling, shipping and storage. It is made of a high-temperature, molded sealing material that can withstand 80°C and a rinse pressure of 110 lbs per square inch.

Recommended Solder Fluxes

Solder fluxes used with the HFBR-53A5VEMZ/FMZ should be water-soluble, organic fluxes. Recommended solder fluxes include Lonco 3355-11 from London Chemical West, Inc. of Burbank, CA, and 100 Flux from Alpha-Metals of Jersey City, NJ.

Recommended Cleaning/Degrading Chemicals

Alcohols: methyl, isopropyl, isobutyl.

Aliphatics: hexane, heptane.

Other: soap solution, naphtha.

Do not use partially halogenated hydrocarbons such as 1,1,1 trichloroethane, ketones such as MEK, acetone, chloroform, ethyl acetate, methylene dichloride, phenol, methylene chloride, or N-methylpyrrolidone. Also, Avago does not recommend the use of cleaners that use halogenated hydrocarbons because of their potential environmental harm.

Regulatory Compliance

(See the Regulatory Compliance Table for transceiver performance)

The overall equipment design will determine the certification level. The transceiver performance is offered as a figure of merit to assist the designer in considering their use in equipment designs.

Electrostatic Discharge (ESD)

There are two design cases in which immunity to ESD damage is important.

The first case is during handling of the transceiver prior to mounting it on the circuit board. It is important to use normal ESD handling precautions for ESD sensitive devices. These precautions include using grounded wrist straps, work benches, and floor mats in ESD controlled areas. The transceiver performance has been shown to provide adequate performance in typical industry production environments.

The second case to consider is static discharges to the exterior of the equipment chassis containing the transceiver parts. To the extent that the duplex SC connector receptacle is exposed to the outside of the equipment chassis it may be subject to whatever system-level ESD test criteria that the equipment is intended to meet. The transceiver performance is more robust than typical industry equipment requirements of today.

Electromagnetic Interference (EMI)

Most equipment designs utilizing these high-speed transceivers from Avago will be required to meet the requirements of FCC in the United States, CEN-ELEC EN55022 (CISPR 22) in Europe and VCCI in Japan. Refer to EMI section (page 4) for more details.

Immunity

Equipment utilizing these transceivers will be subject to radio-frequency electromagnetic fields in some environments. These transceivers have good immunity to such fields due to their shielded design.

Eye Safety

These laser-based transceivers are classified as AEL Class I (U.S. 21 CFR(J) and AEL Class 1 per EN 60825-1 (+A11)). They are eye safe when used within the data sheet limits per CDRH. They are also eye safe under normal operating conditions and under all reasonably foreseeable single fault conditions per EN60825-1. Avago has tested the transceiver design for compliance with the requirements listed below under normal operating conditions and under single fault conditions where applicable. TÜV Rheinland has granted certification to these transceivers for laser eye safety and use in EN 60950 and EN 60825-2 applications. Their performance enables the transceivers to be used without concern for eye safety up to maximum volts transmitter V_{CC} .

CAUTION:

There are no user serviceable parts nor any maintenance required for the HFBR-53A5VEMZ/FMZ. All adjustments are made at the factory before shipment to our customers. Tampering with or modifying the performance of the HFBR-53A5VEMZ/FMZ will result in voided product warranty. It may also result in improper operation of the HFBR-53A5VEMZ/FMZ circuitry, and possible overstress of the laser source. Device degradation or product failure may result.

Connection of the HFBR-53A5VEMZ/FMZ to a non-approved optical source, operating above the recommended absolute maximum conditions or operating the HFBR-53A5VEMZ/FMZ in a manner inconsistent with its design and function may result in hazardous radiation exposure and may be considered an act of modifying or manufacturing a laser product. The person(s) performing such an act is required by law to recertify and reidentify the laser product under the provisions of U.S. 21 CFR (Subchapter J).

Regulatory Compliance

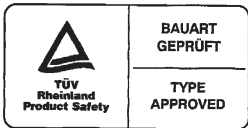
Feature	Test Method	Performance
Electrostatic Discharge (ESD) to the Electrical Pins	MIL-STD-883C Method 3015.7	Class 1 (>1500 V).
Electrostatic Discharge (ESD) to the Duplex SC Receptacle	Variation of IEC 61000-4-2	Typically withstand at least 15 kV without damage when the duplex SC connector receptacle is contacted by a Human Body Model probe.
Electromagnetic Interference (EMI)	FCC Class B CENELEC EN55022 Class B (CISPR 22A) VCCI Class I	Margins are dependent on customer board and chassis designs.
Immunity	Variation of IEC 61000-4-3	Typically show no measurable effect from a 10V/m field swept from 80 to 1000 MHz applied to the transceiver without a chassis enclosure.
Laser Eye Safety and Equipment Type Testing	US 21 CFR, Subchapter J per Paragraphs 1002.10 and 1002.12	AEL Class I, FDA/CDRH HFBR-53A5V*MZ Accession #9720151
	EN 60825-1: 1994 + A1 + A2 EN 60825-2: 2000 EN 60950: 2000	AEL Class 1, TUV Rheinland of North America HFBR-53A5V*MZ: Certificate #R72040311 Protection Class III
Component Recognition	Underwriters Laboratories and Canadian Standards Association Joint Component Recognition for Information Technology Equipment Including Electrical Business Equipment.	UL File E173874
RoHS Compliance		Reference to EU RoHS Directive 2002/95/EC

APPLICATION SUPPORT

Optical Power Budget and Link Penalties

The worst-case Optical Power Budget (OPB) in dB for a fiber-optic link is determined by the difference between the minimum transmitter output optical power (dBm avg) and the lowest receiver sensitivity (dBm avg). This OPB provides the necessary optical signal range to establish a working fiber-optic link. The OPB is allocated for the fiber-optic cable length and the corresponding link penalties. For proper link performance, all penalties that affect the link performance must be accounted for within the link optical power budget. The Gigabit Ethernet IEEE 802.3z standard identifies, and has modeled, the contributions of these OPB penalties to establish the link length requirements for 62.5/125 μm and 50/125 μm multimode fiber usage. Refer to the IEEE 802.3z standard and its supplemental documents that develop the model, empirical results and final specifications.

Data Line Interconnections

Avago's HFBR-53A5VEMZ/FMZ fiber-optic transceiver is designed for compatible PECL signals. The transmitter inputs are internally ac-coupled to the laser driver circuit from the transmitter input pins (pins 7, 8). The transmitter driver circuit for the laser light source is an ac-coupled circuit. This circuit regulates the output optical power. The regulated light output will maintain a constant output optical power provided the data pattern is reasonably balanced in duty factor. If the data duty factor has long, continuous state times (low or high data duty factor), then the output optical power will gradually change its average output optical power level to its pre-set value.

The receiver section is internally ac-coupled between the pre-amplifier and the post-amplifier stages. The actual Data and Data-bar outputs of the post-amplifier are ac-coupled to their respective output pins (pins 2, 3). Signal Detect is a single-ended, TTL output signal that is dc-coupled to pin 4 of the module. Signal Detect should not be ac-coupled externally to the follow-on circuits because of its infrequent state changes.

Caution should be taken to account for the proper interconnection between the supporting Physical Layer integrated circuits and this HFBR-53A5VEMZ/FMZ transceiver. Figure 3 illustrates a recommended interface circuit for interconnecting to a dc PECL compatible fiber-optic transceiver.

Eye Safety Circuit

For an optical transmitter device to be eye-safe in the event of a single fault failure, the transmitter must either maintain normal, eye-safe operation or be disabled.

In the HFBR-53A5VEMZ/FMZ there are three key elements to the laser driver safety circuitry: a monitor diode, a window detector circuit, and direct control of the laser bias. The window detection circuit monitors the average optical power using the monitor diode. If a fault occurs such that the transmitter DC regulation circuit cannot maintain the preset bias conditions for the laser emitter within $\pm 20\%$, the transmitter will automatically be disabled. Once this has occurred, only an electrical power reset will allow an attempted turn-on of the transmitter.

Signal Detect

The Signal Detect circuit provides a deasserted output signal that implies the link is open or the transmitter is OFF as defined by the Gigabit Ethernet specification IEEE 802.3z, Table 38.1. The Signal Detect threshold is set to transition from a high to low state between the minimum receiver input optional power and -30 dBm avg. input optical power indicating a definite optical fault (e.g., unplugged connector for the receiver or transmitter, broken fiber, or failed far-end transmitter or data source). A Signal Detect indicating a working link is functional when receiving encoded 8B/10B characters. The Signal Detect does not detect receiver data error or error-rate. Data errors are determined by Signal processing following the transceiver.

Electromagnetic Interference (EMI)

One of a circuit board designer's foremost concerns is the control of electromagnetic emissions from electronic equipment. Success in controlling generated Electromagnetic Interference (EMI) enables the designer to pass a governmental agency's EMI regulatory standard; and more importantly, it reduces the possibility of interference to neighboring equipment. The EMI performance of an enclosure using these transceivers is dependent on the chassis design. Avago encourages using standard RF suppression practices and avoiding poorly EMI-sealed enclosures.

Absolute Maximum Ratings

Stresses in excess of the absolute maximum ratings can cause catastrophic damage to the device. Limits apply to each parameter in isolation, all other parameters having values within the recommended operating conditions. It should not be assumed that limiting values of more than one parameter can be applied to the product at the same time. Exposure to the absolute maximum ratings for extended periods can adversely affect device reliability.

Parameter	Symbol	Min.	Typ.	Max.	Unit	Reference
Storage Temperature	T_S	-40		+100	°C	
Supply Voltage	V_{CC}	-0.5		5.0	V	1
Transmitter Differential Input Voltage	V_D			2.2	V	
Relative Humidity	RH	5		95	%	
TTL Signal Detect Current – Low	$I_{OL, MAX}$	-5			mA	
TTL Signal Detect Current – High	$I_{OH, MAX}$			4.0	mA	

Recommended Operating Conditions

Parameter	Symbol	Min.	Typ.	Max.	Unit	Reference
Ambient Operating Temperature	T_A	0		70	°C	
Case Temperature	T_C			80	°C	2
Supply Voltage	V_{CC}	3.14	3.3	3.47	V	
Power Supply Rejection	PSR		100		mV _{p-p}	3
Transmitter Differential Input Voltage	V_D	0.4		1.6	V	
Data Output Load	R_{DL}		50		Ω	
TTL Signal Detect Output Current	I_{OL}			1.0	mA	
TTL Signal Detect Output Current	I_{OH}	-400			μA	

Process Compatibility

Parameter	Symbol	Min.	Typ.	Max.	Unit	Reference
Hand Lead Soldering Temperature/Time	T_{SOLD}/t_{SOLD}			+260/10	°C/s	
Wave Soldering and Aqueous Wash	T_{SOLD}/t_{SOLD}			+260/10	°C/s	4

Notes:

1. The transceiver is class 1 eye safe up to $V_{CC} = 5.0$ V.
2. Case temperature measurement referenced to the center top of the internal metal transmitter shield.
3. Tested with a 100 mV_{p-p} sinusoidal signal in the frequency range from 10 Hz to 2 MHz on the V_{CC} supply with the recommended power supply filter in place. Typically less than a 1 dB change in sensitivity is experienced.
4. Aqueous wash pressure < 110 psi.

**HFBR-53A5VEMZ/FMZ, 850 nm VCSEL
Transmitter Electrical Characteristics**
($T_A = 0^\circ\text{C}$ to $+70^\circ\text{C}$, $V_{CC} = 3.14\text{ V}$ to 3.47 V)

Parameter	Symbol	Min.	Typ.	Max.	Unit	Reference
Supply Current	I_{CCT}		55	75	mA	
Power Dissipation	P_{DIST}		0.18	0.26	W	
Laser Reset Voltage	$V_{CCT-reset}$		2.5	2.0	V	1

Receiver Electrical Characteristics
($T_A = 0^\circ\text{C}$ to $+70^\circ\text{C}$, $V_{CC} = 3.14\text{ V}$ to 3.47 V)

Parameter	Symbol	Min.	Typ.	Max.	Unit	Reference
Supply Current	I_{CCR}		80	135	mA	
Power Dissipation	P_{DISR}		0.26	0.47	W	
Data Output Voltage – Peak to Peak Differential	V_{OPP}	0.4		2	V	2
Data Output Rise Time	t_r			0.40	ns	3
Data Output Fall Time	t_f			0.40	ns	3
Signal Detect Output Voltage – Low	V_{OL}			0.6	V	4
Signal Detect Output Voltage – High	V_{OH}	2.2			V	4
Signal Detect Assert Time	t_{SDA}			100	μs	
Signal Detect Deassert Time	t_{SDD}			350	μs	

Notes:

1. The Laser Reset Voltage is the voltage level below which the V_{CCT} voltage must be lowered to cause the laser driver circuit to reset from an electrical/optical shutdown condition to a proper electrical/optical operating condition. The maximum value corresponds to the worst-case highest V_{CC} voltage necessary to cause a reset condition to occur. The laser safety shutdown circuit will operate properly with transmitter V_{CC} levels of $2.5\text{ Vdc} \leq V_{CC} \leq 5.0\text{ Vdc}$.
2. These outputs are compatible with 10 K, 10 KH, and 100 K ECL and PECL inputs.
3. These are 20-80% values.
4. Under recommended operating conditions.

HFBR-53A5VEMZ/FMZ, 850 nm VCSEL Transmitter Optical Characteristics

($T_A = 0^\circ\text{C}$ to $+70^\circ\text{C}$, $V_{CC} = 3.14\text{ V}$ to 3.47 V)

Parameter	Symbol	Min.	Typ.	Max.	Unit	Reference
Output Optical Power 50/125 μm , NA = 0.20 Fiber	P_{OUT}	-9.5		-4	dBm avg.	1
Output Optical Power 62.5/125 μm , NA = 0.275 Fiber	P_{OUT}	-9.5		-4	dBm avg.	1
Optical Extinction Ratio		9			dB	2
Center Wavelength	λ_C	830	850	860	nm	
Spectral Width – rms	σ			0.85	nm rms	
Optical Rise/Fall Time	t_r/t_f			0.26	ns	3, 4, Figure 1
RIN_{12}				-117	dB/Hz	
Coupled Power Ratio	CPR	9			dB	5
Total Transmitter Jitter Added at TP2				227	ps	6

Receiver Optical Characteristics

($T_A = 0^\circ\text{C}$ to $+70^\circ\text{C}$, $V_{CC} = 3.14\text{ V}$ to 3.47 V)

Parameter	Symbol	Min.	Typ.	Max.	Unit	Reference
Input Optical Power	P_{IN}	-17		0	dBm avg.	7
Stressed Receiver Sensitivity	62.5 μm			-12.5	dBm avg.	8
	50 μm			-13.5	dBm avg.	8
Stressed Receiver Eye Opening at TP4		201			ps	6, 9
Receive Electrical 3 dB Upper Cutoff Frequency				1500	MHz	10
Operating Center Wavelength	λ_C	770		860	nm	
Return Loss		12			dB	11
Signal Detect – Asserted	P_A			-17	dBm avg.	12
Signal Detect – Deasserted	P_D	-30			dBm avg.	12
Signal Detect – Hysteresis	$P_A - P_D$	1.5			dB	12

Notes:

1. The maximum Optical Output Power complies with the IEEE 802.3z specification, and is class 1 laser eye safe.
2. Optical Extinction Ratio is defined as the ratio of the average optical power of the transmitter in the high ("1") state to the low ("0") state. Extinction Ratio shall be measured using the methods specified in TIA/EIA.526.4A. This measurement may be made with the node transmitting a 36A.3 data pattern. The Saturation Ratio is measured under fully modulated conditions with worst case reflections. A36A.3 data pattern is a repeating K28.7 data pattern which generates a 125 mHz square wave.
3. These are unfiltered 20-80% values.
4. Laser transmitter pulse response characteristics are specified by an eye diagram (Figure 1). The characteristics include rise time, fall time, pulse overshoot, pulse undershoot, and ringing, all of which are controlled to prevent excessive degradation of the receiver sensitivity. These parameters are specified by the referenced Gigabit Ethernet eye diagram using the required filter. The output optical waveform complies with the requirements of the eye mask discussed in section 38.6.5 and Fig. 38-2 of IEEE 802.3z.
5. CPR is measured in accordance with EIA/TIA-526-14A as referenced in 802.3z, section 38.6.10.
6. TP refers to the compliance point specified in 802.3z, section 38.2.1.
7. The receive sensitivity is measured using a worst case extinction ratio penalty while sampling at the center of the eye.
8. The stressed receiver sensitivity is measured using the conformance test signal defined in 802.3z, section 38.6.11. The conformance test signal is conditioned by applying deterministic jitter and intersymbol interference.
9. The stressed receiver jitter is measured using the conformance test signal defined in 802.3z, section 38.6.11 and set to an average optical power 0.5 dB greater than the specified stressed receiver sensitivity.
10. The 3 dB electrical bandwidth of the receiver is measured using the technique outlined in 802.3z, section 38.6.12.
11. Return loss is defined as the minimum attenuation (dB) of received optical power for energy reflected back into the optical fiber.
12. With valid 8B/10B encoded data.

Table 1. Pinout Table

Pin	Symbol	Functional Description
Mounting Pins		The mounting pins are provided for transceiver mechanical attachment to the circuit board. They are embedded in the nonconductive plastic housing and are not connected to the transceiver internal circuit, nor is there a guaranteed connection to the metallized housing in the EM and FM versions. They should be soldered into plated-through holes on the printed circuit board.
1	V _{EER}	Receiver Signal Ground Directly connect this pin to receiver signal ground plane. (V _{EER} = V _{EET})
2	RD+	Receiver Data Out AC coupled – PECL compatible.
3	RD-	Receiver Data Out Bar AC coupled – PECL compatible.
4	SD	Signal Detect Signal Detect is a single-ended TTL output. If Signal Detect output is not used, leave it open-circuited. Normal optical input levels to the receiver result in a logic “1” output, V _{OH} , asserted. Low input optical levels to the receiver result in a fault condition indicated by a logic “0” output V _{OL} , deasserted.
5	V _{CCR}	Receiver Power Supply Provide +3.3 Vdc via the recommended receiver power supply filter circuit. Locate the power supply filter circuit as close as possible to the V _{CCR} pin.
6	V _{CCT}	Transmitter Power Supply Provide +3.3 Vdc via the recommended transmitter power supply filter circuit. Locate the power supply filter circuit as close as possible to the V _{CCT} pin.
7	TD-	Transmitter Data In-Bar AC coupled – PECL compatible. Internally terminated differentially with 100 Ω.
8	TD+	Transmitter Data In AC coupled – PECL compatible. Internally terminated differentially with 100 Ω.
9	V _{EET}	Transmitter Signal Ground Directly connect this pin to the transmitter signal ground plane.

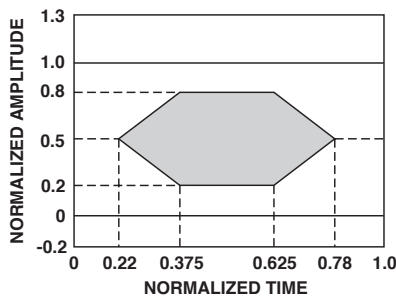
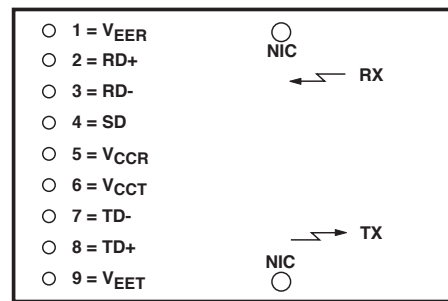

Figure 1. Transmitter optical eye diagram mask



TOP VIEW
NIC = NO INTERNAL CONNECTION (MOUNTING PINS)

Figure 2. Pin-out

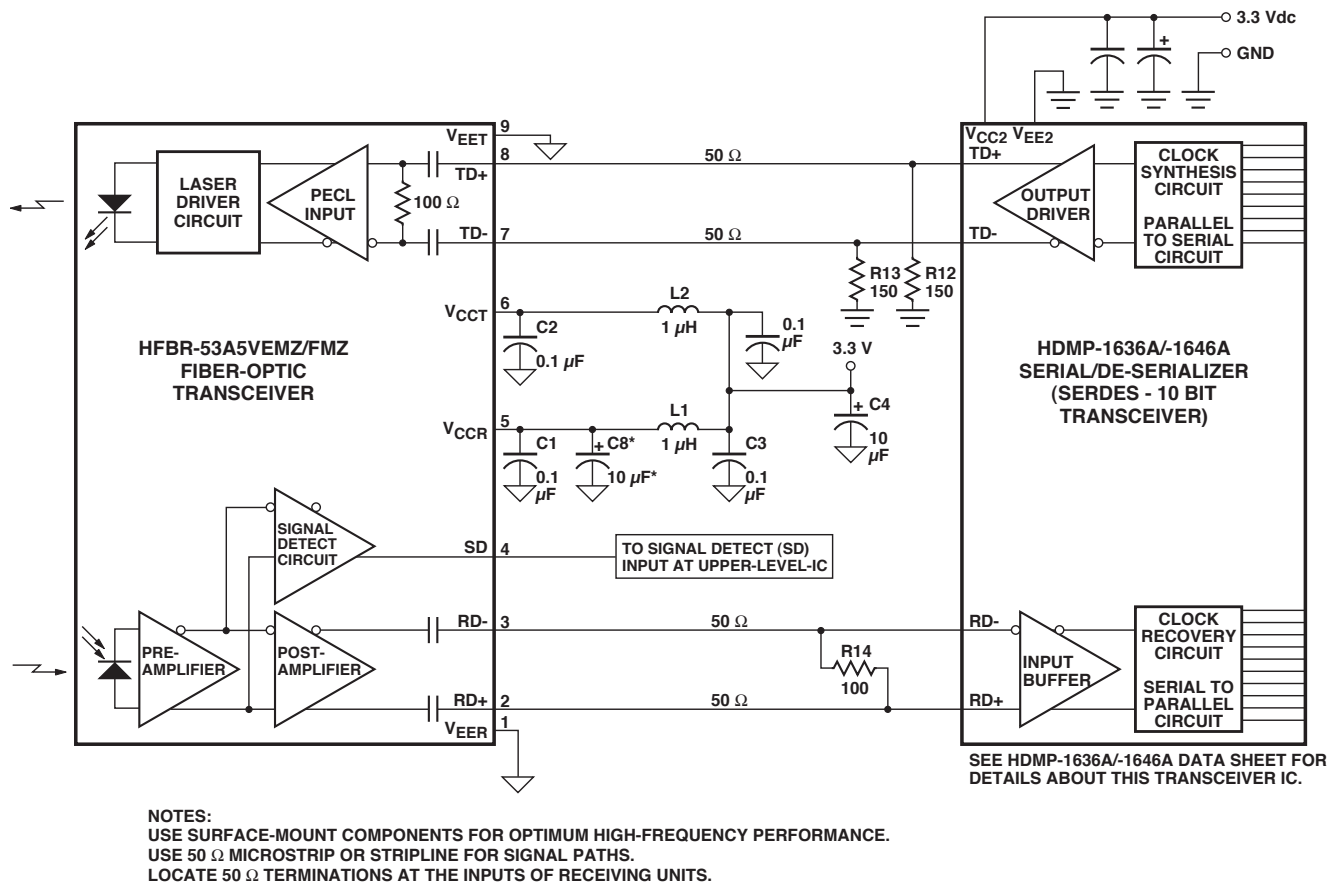

Figure 3. Recommended Gigabit/sec Ethernet HFBR-53A5VEMZ/FMZ fiber-optic transceiver and HDMP-1636A/1646A SERDES integrated circuit transceiver interface and power supply filter circuits

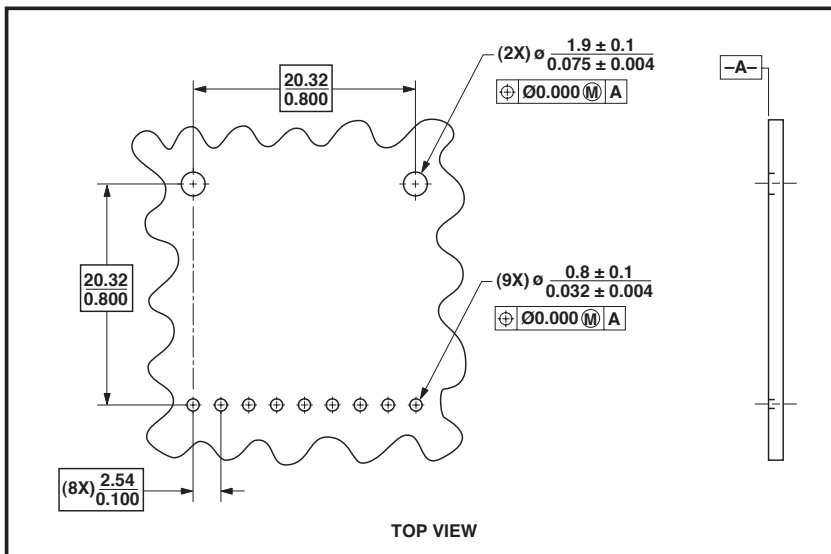

Figure 4. Recommended board layout hole pattern

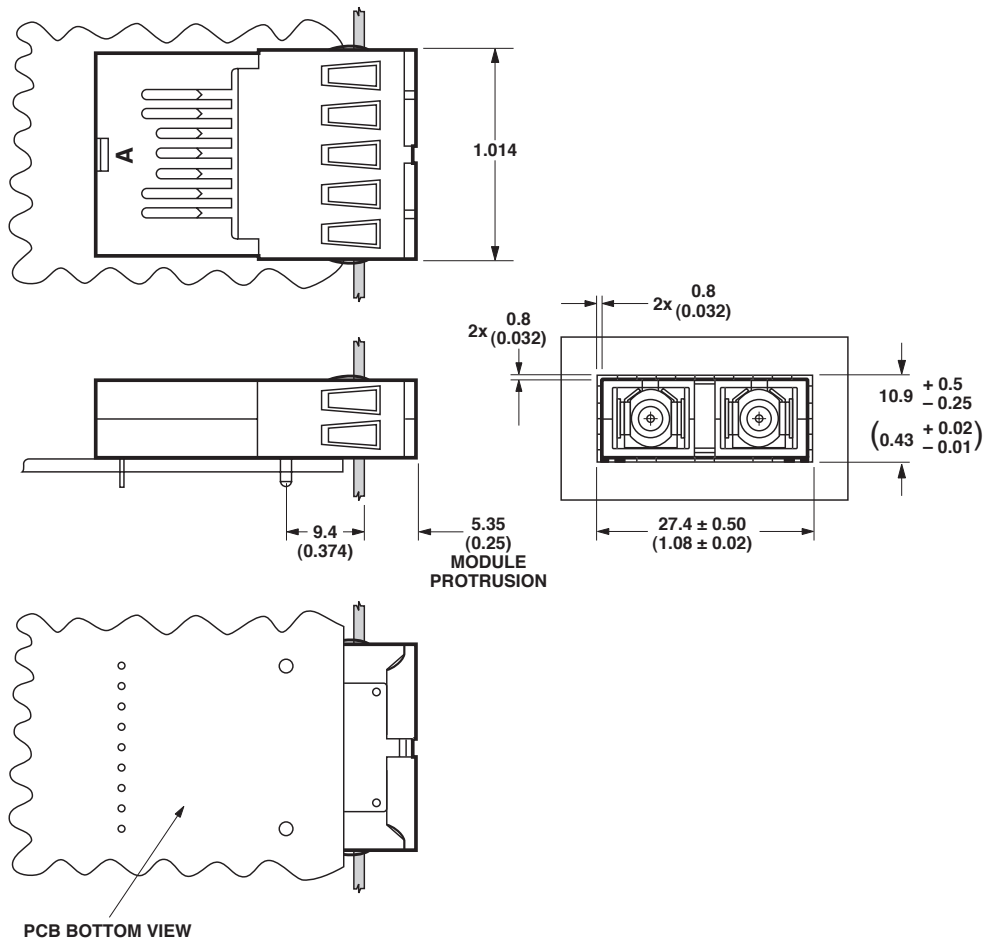

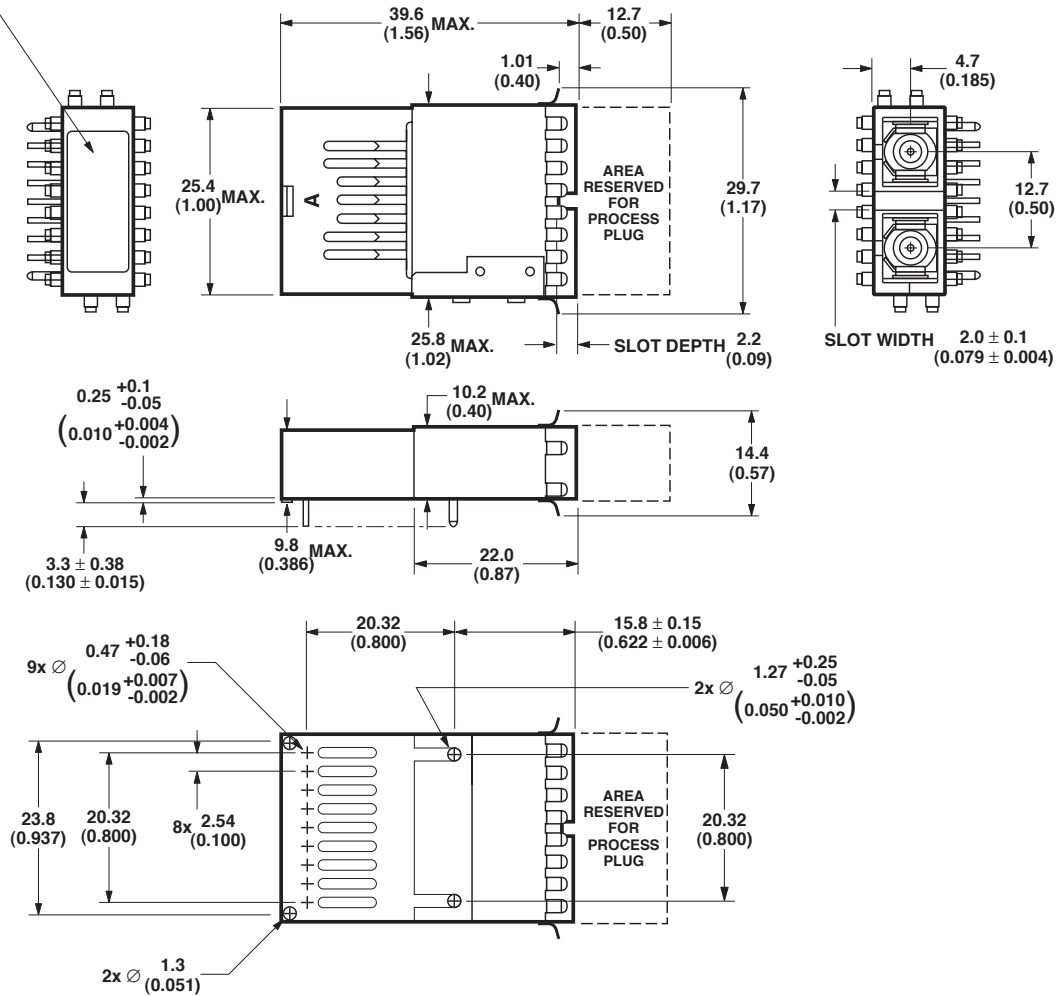

Figure 6. Suggested module positioning and panel cut-out for HFBR-53A5VEMZ

A
 XXXX-XXXX
 ZZZZ LASER PROD
 21CFR(J) CLASS 1
 COUNTRY OF ORIGIN YYWW
 TX  RX

KEY:
 YYWW = DATE CODE
 FOR MULTIMODE MODULE:
 XXXX-XXXX = HFBR-53xx
 ZZZZ = 850 nm



DIMENSIONS ARE IN MILLIMETERS (INCHES).
 ALL DIMENSIONS ARE ± 0.025 mm UNLESS OTHERWISE SPECIFIED.

Figure 7. Package outline for HFBR-53A5VFMZ

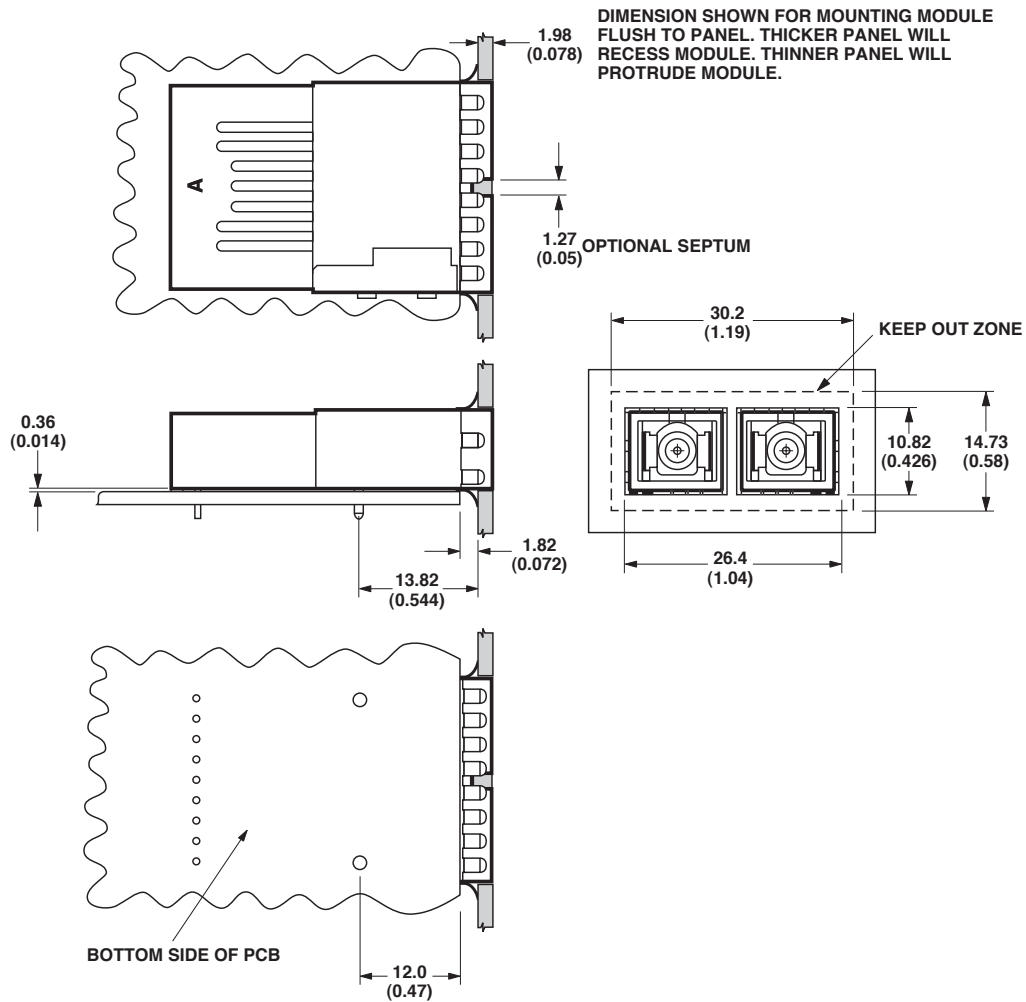

DIMENSIONS ARE IN MILLIMETERS (INCHES).
ALL DIMENSIONS ARE ± 0.025 mm UNLESS OTHERWISE SPECIFIED.

Figure 8. Suggested module positioning and panel cut-out for HFBR-53A5VMZ

Ordering Information

850 nm VCSEL	(SX – Short Wavelength Laser)
HFBR-53A5VEMZ	Extended shield, metal housing.
HFBR-53A5VMZ	Flush shield, metal housing.

For product information and a complete list of distributors, please go to our website: www.avagotech.com

Avago, Avago Technologies, and the A logo are trademarks of Avago Technologies Limited in the United States and other countries.
Data subject to change. Copyright © 2008 Avago Technologies Limited. All rights reserved. Obsoletes AV01-0386EN
AV02-1268EN May 13, 2008

