

# ABCU-5710RZ / ABCU-5700RZ

1000BASE-T 1.25 Gbd Small Form Pluggable Low Voltage (3.3 V)

Electrical Transceiver over Category 5 Cable



## Data Sheet

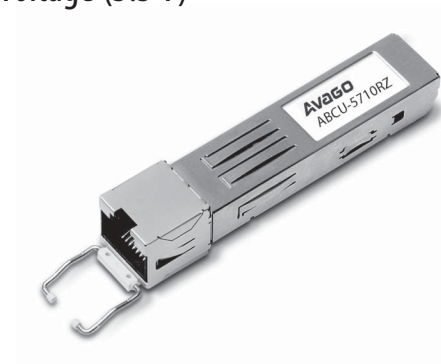

### Description

The ABCU-5710RZ and ABCU-5700RZ electrical transceivers from Avago Technologies offer full-duplex throughput of 1000 Mbps by transporting data over shielded and unshielded twisted pair category 5 cable with 5-level PAM (Pulse Amplitude Modulation) signals. The ABCU-5710RZ and ABCU-5700RZ differ only in handling of RX\_LOS signal functions, as explained further on the following pages.

The Avago Technologies 1000BASE-T module takes signals from both the twisted pair category 5 cable and the SerDes interface. Pin count overhead between the MAC and the PHY is minimized, and Gigabit Ethernet operation is achieved with maximum space savings.

### Module Diagrams

Figure 1 illustrates the major functional components of the ABCU-5700/5710RZ. The 20-pin connection diagram of module printed circuit board of the module is shown in Figure 2. Figure 3 depicts the pin assignment of the MDI (RJ45 jack).

Figure 6 depicts the external configuration and dimensions of the module.

### Features

- RoHS-6 Compliant (see Table 1)
- Designed for Industry-Standard, MSA Compliant Small Form Factor Pluggable (SFP) Ports
- Compatible with IEEE 802.3:2000
- Custom RJ-45 connector with integrated magnetics
- Link lengths at 1.25 Gbd: up to 100 m per IEEE802.3
- Low power, high performance 1.25 Gbd SerDes integrated in module
- Single +3.3 V power supply operation
- Auto-negotiation per IEEE 802.3:2000 Clause 28 (Twisted Pair) and Clause 37 (1000BASE-X)
- Compatible to both shielded and unshielded twisted pair category 5 cable
- Two configurations:
  - ABCU-5700RZ: RX\_LOS enabled
  - ABCU-5710RZ: RX\_LOS disabled
- Rated for Commercial Temperature applications (0° - 70° C)

### Applications

- Switch to switch interface
- Switched backplane applications
- File server interface

### Related Products

- AFBR-5710Z: Family of 850nm +3.3V SFP optical transceivers for Gigabit Ethernet
- AFCT-5710Z: Family of 1310nm +3.3V SFP optical transceivers for Gigabit Ethernet

## Installation

The ABCU-5700/5710RZ can be installed in or removed from any MultiSource Agreement (MSA) compliant Small Form Pluggable port whether the host equipment is operating or not. The module is simply inserted, small end first, under finger-pressure. Controlled hot-plugging is ensured by design and by 3-stage pin sequencing at the electrical interface to the host board. The module housing makes initial contact with the host board EMI shield, mitigating potential damage due to Electro-Static Discharge (ESD). The module pins sequentially contact the (1) Ground, (2) Power, and (3) Signal pins of the host board surface mount connector. This printed circuit board card-edge connector is depicted in Figure 2.

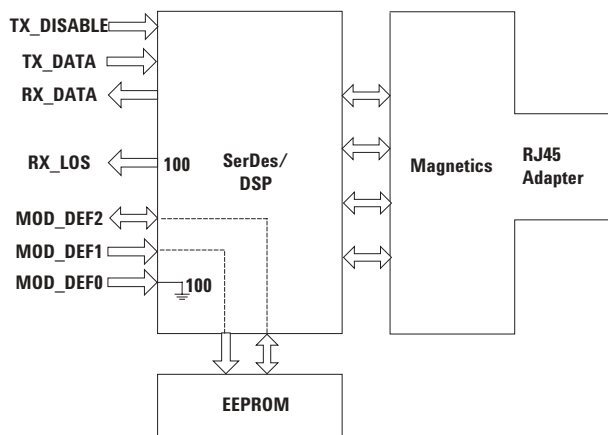
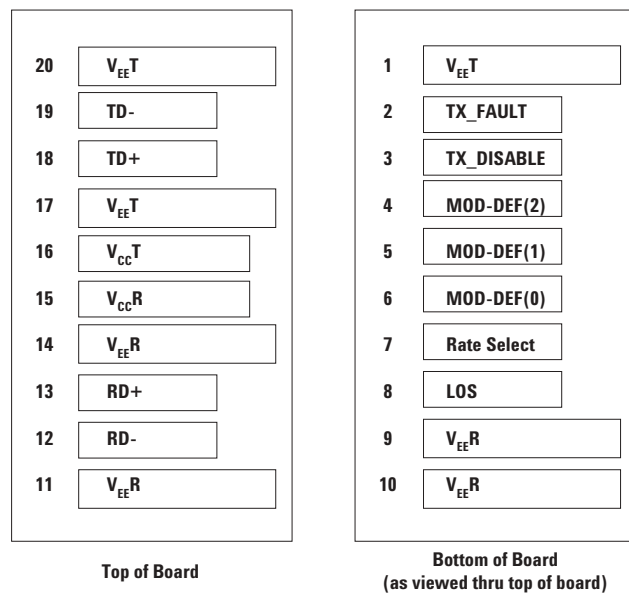

Figure 1. Transceiver Functional Diagram



Note:  
TxFault, LOS and Rate\_Select not used.

Figure 2. 20-pin Connection Diagram of Module Printed Circuit Board

## Serial Identification (EEPROM)

The ABCU-5700/5710RZ complies with an industry standard MultiSource Agreement that defines the serial identification protocol. This protocol uses the 2-wire serial CMOS EEPROM protocol of the ATMEL AT24C01A or equivalent. The contents of the ABCU-5700/5710RZ serial ID memory are defined in Table 10 as specified in the SFP MSA.

## Controller and Data I/O

Data I/Os are designed to accept industry standard differential signals. In order to reduce the number of passive components required on the customer's board, Avago Technologies has included the functionality of the transmitter bias resistors and coupling capacitors within the module. The transceiver is compatible with an "ac-coupled" configuration and is internally terminated. Figure 1 depicts the functional diagram of the ABCU-5700/5710RZ. 100-ohm resistor shown at RX\_LOS in Figure 1 refers to ABCU-5710RZ configuration, not ABCU-5700RZ configuration.

Caution should be taken into account for the proper interconnection between the supporting Physical Layer integrated circuits and the ABCU-5700/5710RZ.

Figure 4 illustrates the recommended interface circuit.

Several control data signals and timing diagrams are implemented in the module and are depicted in Figure 6.

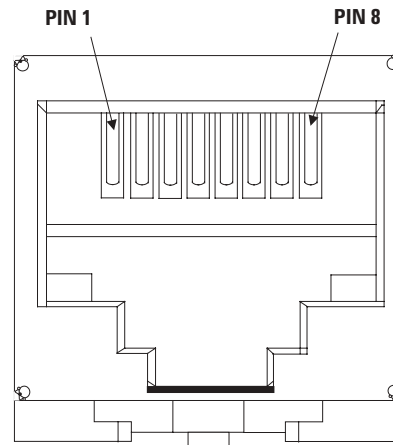

Figure 3. MDI (RJ 45 Jack) Pin Assignment

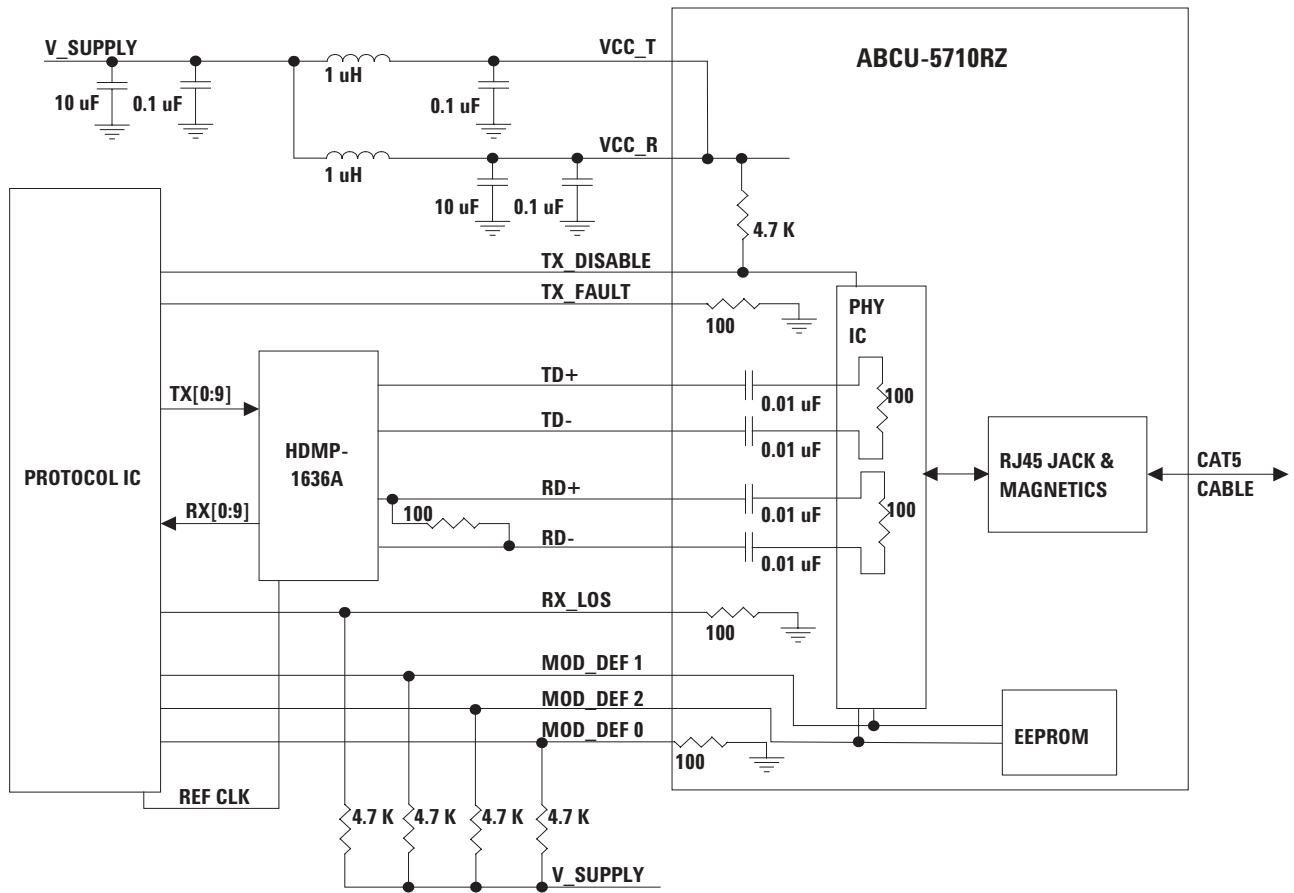
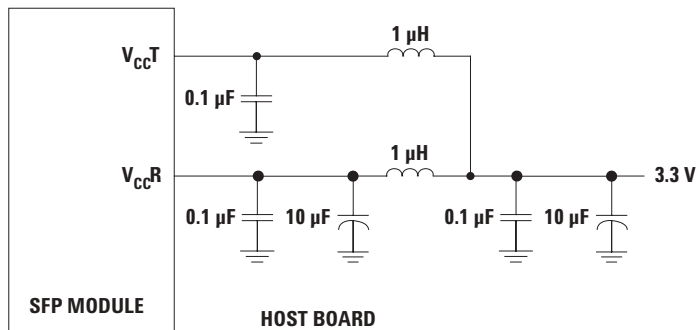

Figure 4. Typical Application Configuration for ABCU-5710RZ



Note: Inductors must have less than 1ohm series resistance per MSA

Figure 5. MSA Recommended Power Supply Filter

## Application Support

### Evaluation Kit

To help you in your preliminary transceiver evaluation, Avago Technologies offers a 1.25 GBd Gigabit Ethernet evaluation board. This board will allow testing of the electrical parameters of transceiver. Please contact your local Field Sales representative for availability and ordering details.

### Reference Designs

Reference designs for the SFP transceiver and the HDMP-1636A physical layer IC are available to assist the equipment designer. Figure 4 depicts a typical application configuration, while Figure 5 depicts the MSA power supply filter circuit design. Please contact your local Field Sales engineer for more information regarding application tools.

### Regulatory Compliance

See Table 1 for transceiver Regulatory Compliance performance. The overall equipment design will determine the certification level. The transceiver performance is offered as a figure of merit to assist the designer.

**Table 1. Regulatory Compliance**

Feature	Test Method	Performance
Electrostatic Discharge (ESD) to the Electrical Pins	MIL-STD-883C Method 3015.4 JEDEC/EIA JES022-A114-A	Class 2 (2000 Volts)
Electrostatic Discharge (ESD) to the RJ 45 Connector Receptacle	Variation of IEC 61000-4-2	Typically withstand 15 KV ( Air Discharge), 8 KV (Contact) without damage when the RJ 45 connector receptacle is contacted by a Human Body Model probe.
Electromagnetic Interference (EMI)	FCC Part 15 Class B CENELEC EN55022 Class B (CISPR 22A) VCCI Class 1	System margins are dependent on customer board and chassis design.
Radiated Immunity	Variation of IEC 61000-4-3	Typically shows a negligible effect from a 10 V/m field swept from 80 to 1000 MHz applied to the transceiver without a chassis enclosure.
Component Recognition	Underwriters Laboratories and Canadian Standards Association Joint Component Recognition for Information Technology Equipment Including Electrical Business Equipment	UL File # E173874
Grounding Configuration	DC short between signal and chassis grounds	- Meets all regulatory requirements as listed above. - Compliant with system boards using multi-point grounding scheme
ROHS Compliance	Chemical composition analysis	Less than 0.1% lead, mercury, hexavalent chromium, polybrominated biphenyls, and polybrominated biphenyl ethers by weight of homogeneous material. Exemption for lead in high melting temperature solder applied to module connector. Less than 0.01% cadmium by weight of homogeneous material.

## Electrostatic Discharge (ESD)

There are two conditions in which immunity to ESD damage is important. Table 1 documents our immunity to both of these conditions. The first condition is during handling of the transceiver prior to insertion into the transceiver port. To protect the transceiver, it is important to use normal ESD handling precautions. These precautions include using grounded wrist straps, work benches, and floor mats in ESD controlled areas. The ESD sensitivity of the ABCU-5700/5710RZ is compatible with typical industry production environments.

The second condition is static discharges to the exterior of the host equipment chassis after installation. To the extent that the RJ45 connector interface is exposed to the outside of the host equipment chassis, it may be subject to system-level ESD requirements. The ESD performance of the ABCU-5700/5710RZ exceeds typical industry standards.

## Immunity

Equipment hosting the ABCU-5700/5710RZ modules will be subjected to radio-frequency electromagnetic fields in some environments. The transceivers have excellent immunity to such fields due to their shielded design.

### **Electromagnetic Interference (EMI)**

Most equipment designs utilizing these high-speed transceivers from Avago Technologies will be required to meet the requirements of FCC in the United States, CENELEC EN55022 (CISPR 22A) in Europe and VCCI in Japan.

The metal housing and shielded design minimize the EMI challenge facing the host equipment designer. These transceivers provide superior EMI performance. This greatly assists the designer in the management of the overall system EMI performance.

### **Flammability**

The ABCU-5700/5710RZ electrical transceiver housing is made of metal and high strength, heat resistant, chemically resistant, and UL 94V-0 flame retardant plastic.

### **Caution**

There are no user serviceable parts nor any maintenance required for the ABCU-5700/5710RZ. Tampering with or modifying the performance will result in voided product warranty. It may also result in improper operation of the ABCU-5700/5710RZ circuitry, and possible overstress of the RJ 45 connector. Device degradation or product failure may result. Connecting the module to a non-approved 1000BaseT module, operating above the recommended absolute maximum conditions or operating the ABCU-5710RZ in a manner inconsistent with its design and function may result in hazardous radiation exposure and may be considered an act of modifying or manufacturing an electrical module product.

### **Ordering Information**

Please contact your local field sales engineer or one of Avago Technologies franchised distributors for ordering information. For technical information, please visit Avago Technologies web page at [www.avagotech.com](http://www.avagotech.com) or contact Avago Technologies Customer Response Center. For information related to the MSA visit [www.schelto.com/SFP/index.html](http://www.schelto.com/SFP/index.html)

### **Customer Manufacturing Processes**

This module is pluggable and is not designed for aqueous wash, IR reflow or wave soldering processes.

**Table 2. 20-pin Connection Diagram Description**

Pin	Name	Function/Description	MSA Notes
1	V <sub>EE</sub> T	Transmitter Ground	
2	TX Fault	Transmitter Fault Indication - High Indicates a Fault	Note 1
3	TX Disable	Transmitter Disable - Module disables on high or open	Note 2
4	MOD-DEF2	Module Definition 2 - Two wire serial ID interface	Note 3
5	MOD-DEF1	Module Definition 1 - Two wire serial ID interface	Note 3
6	MOD-DEF0	Module Definition 0 - Grounded in module	Note 3
7	Rate Select	Not Connected	
8	LOS	Loss of Signal - High Indicates Loss of Signal	Note 4
9	V <sub>EE</sub> R	Receiver Ground	
10	V <sub>EE</sub> R	Receiver Ground	
11	V <sub>EE</sub> R	Receiver Ground	
12	RD-	Inverse Received Data Out	Note 5
13	RD+	Received Data Out	Note 5
14	V <sub>EE</sub> R	Receiver Ground	
15	V <sub>CC</sub> R	Receiver Power - 3.3 V +/- 5%	Note 6
16	V <sub>CC</sub> T	Transmitter Power - 3.3 V +/- 5%	Note 6
17	V <sub>EE</sub> T	Transmitter Ground	
18	TD+	Transmitter Data In	Note 7
19	TD-	Inverse Transmitter Data In	Note 7
20	V <sub>EE</sub> T	Transmitter Ground	

**Notes:**

- TX Fault is not used and is always tied to ground through a 100 ohm resistor.
- TX Disable as described in the MSA is not applicable to the 1000BASE-T module, but is used for convenience as an input to reset the internal ASIC. This pin is pulled up within the module with a 4.7 K $\Omega$  resistor.
  - Low (0 – 0.8 V): Transceiver on
  - Between (0.8 V and 2.0 V): Undefined
  - High (2.0 – 3.465 V): Transceiver in reset state
  - Open: Transceiver in reset state
- Mod-Def 0,1,2. These are the module definition pins. They should be pulled up with a 4.7-10 K $\Omega$  resistor on the host board to a supply less than V<sub>CC</sub>T + 0.3 V or V<sub>CC</sub>R + 0.3 V.
  - Mod Def 0 is tied to ground through a 100 ohm resistor to indicate that the module is present.
  - Mod-Def 1 is clock line of two wire serial interface for optional serial ID
  - Mod-Def 2 is data line of two wire serial interface for optional serial ID
- LOS (Loss of Signal) operation on the 1000BaseT SFP is different than for optical SFP applications. For ABCU-5700RZ, RX\_LOS signal is a 1000BASE-T linkup/link-down indicator and not a peak (AC) or voltage (DC) detector. For ABCU-5710RZ, RX\_LOS is not used and is always tied to ground via 100-ohm resistor.
- RD-/+ : These are the differential receiver outputs. They are ac coupled 100  $\Omega$  differential lines which should be terminated with 100  $\Omega$  differential at the user SerDes. The ac coupling is done inside the module and is thus not required on the host board. The voltage swing on these lines will be between 370 and 2000 mV differential (185 – 1000 mV single ended) when properly terminated. These levels are compatible with CML and LVPECL voltage swings.
- V<sub>CC</sub>R and V<sub>CC</sub>T are the receiver and transmitter power supplies. They are defined as 3.3 V  $\pm$  5% at the SFP connector pin. The maximum supply current is 317 mA and the associated in-rush current will typically be no more than 30 mA above steady state after 500 nanoseconds.
- TD-/+ : These are the differential transmitter inputs. They are ac coupled differential lines with 100  $\Omega$  differential termination inside the module. The ac coupling is done inside the module and is thus not required on the host board. The inputs will accept differential swings of 500 – 2400 mV (250 – 1200 mV single ended), though it is recommended that values between 500 and 1200 mV differential (250 – 600 mV single ended) be used for best EMI performance. These levels are compatible with CML and LVPECL voltage swings.

## Absolute Maximum Ratings

Parameter	Symbol	Minimum	Typical	Maximum	Unit	Notes
Storage Temperature	$T_s$	-40		+75	°C	Note 1
Case Temperature	$T_c$	-40		+75	°C	Note 1, 2
Relative Humidity	RH	5		95	%	Note 1
Module Supply Voltage	$V_{ccT,R}$	-0.5		3.6	V	Note 1, 2
Data/Control Input Voltage	$V_I$	-0.5		$V_{cc}$	V	Note 1
Sense Output Current - LOS	$I_D$			NA	mA	Note 1
Sense Output Current - MOD-DEF2				5.0		

## Recommended Operating Conditions

Parameter	Symbol	Minimum	Typical	Maximum	Unit	Notes
Case Temperature	$T_c$	0		70	°C	Note 3
Module Supply Voltage	$V_{ccT,R}$	3.135	3.3	3.465	V	Note 3
Data Rate			1.25		Gb/s	Note 3

## Transceiver Electrical Characteristics

( $T_c = 0\text{ °C}$  to  $+70\text{ °C}$ ,  $V_{ccT,R} = 3.3\text{ V} \pm 5\%$ )

Parameter	Symbol	Minimum	Typical	Maximum	Unit	Notes
<b>AC Electrical Characteristics</b>						
Power Supply Noise Rejection (peak-peak)	PSNR		100		mV	Note 4
<b>DC Electrical Characteristics</b>						
Module supply current	$I_{cc}$			350	mA	
Power Dissipation	$P_{DISS}$			1100	mW	
<b>Sense Outputs:</b> MOD-DEF2	$V_{DH}$	2.0	3.05	$V_{ccT,R} + 0.3$	V	Note 5
	$V_{DL}$					
<b>Control Inputs:</b> Transmitter Disable (TX_DISABLE), MOD-DEF1, 2	$V_{IH}$	2.0		$V_{cc}$	V	Note 6
	$V_{IL}$	0		0.8	V	

### Notes:

1. Absolute Maximum Ratings are those values beyond which damage to the device may occur if these limits are exceeded for other than a short period of time. See Reliability Data Sheet for specific reliability performance.
2. Between Absolute Maximum Ratings and the Recommended Operating Conditions functional performance is not intended, device reliability is not implied, and damage to the device may occur over an extended period of time.
3. Recommended Operating Conditions are those values outside of which functional performance is not intended, device reliability is not implied, and damage to the device may occur over an extended period of time. See Reliability Data Sheet for specific reliability performance later when it is ready.
4. MSA-specified filter is required on the host board to achieve PSNR performance over the frequency range 10 Hz to 2 MHz.
5. LVTTTL, external 4.7-10 K $\Omega$  pull-Up resistor required.
6. LVTTTL, external 4.7-10 K $\Omega$  pull-Up resistor required for MOD-DEF 1 and MOD-DEF 2.

## Transmitter and Receiver Electrical Characteristics

( $T_C = 0\text{ }^{\circ}\text{C}$  to  $+70\text{ }^{\circ}\text{C}$ ,  $V_{CC,T,R} = 3.3\text{ V} \pm 5\%$ )

Parameter	Symbol	Minimum	Typical	Maximum	Unit	Notes
<b>Data Input:</b> Transmitter Differential Input Voltage (TD +/-)	$V_I$	500		2400	mV	Note 1
<b>Data Output:</b> Receiver Differential Output Voltage (RD +/-)	$V_O$	370	735	2000	mV	Note 2
Receive Data Rise & Fall Times (Receiver)	$T_{rf}$		100	250	ps	Note 3

## Transceiver Timing Characteristics

( $T_C = 0\text{ }^{\circ}\text{C}$  to  $70\text{ }^{\circ}\text{C}$ ,  $V_{CC,T,R} = 3.3\text{ V} \pm 5\%$ )

Parameter	Symbol	Minimum	Typical	Maximum	Unit	Notes
Tx Disable Assert Time	$t_{off}$			NA		Note 4
Tx Disable Negate Time	$t_{on}$			NA		Note 4
Module Reset Assert Time	$t_{off\_rst}$			10	$\mu\text{s}$	Note 5
Module Reset Negate Time	$t_{on\_rst}$			300	ms	Note 6
Time to initialize	$t_{init}$			300	ms	
Tx Fault Assert Time	$t_{fault}$			NA		Note 7
Tx Disable to Reset	$t_{reset}$			NA		Note 7
LOS Assert Time	$t_{loss\_on}$			NA		Note 7
LOS De-assert Time	$t_{loss\_off}$			NA		Note 7
Rate Select Change Time	$t_{ratesel}$			NA		Note 7
Serial ID Clock Rate	$F_{serial\_clock}$			100	kHz	

### Notes:

1. Internally ac coupled and terminated (100 Ohm differential). These levels are compatible with CML and LVPECL voltage swings.
2. Internally ac coupled with an external 100 ohm differential load termination.
3. 20%-80% rise and fall times measured with a 500 MHz signal utilizing a 1010 pattern.
4. Tx Disable function as described in the SFP MSA is not used in the 1000BASE-T module.
5. Time from rising edge of Tx Disable until link comes down.
6. Time from falling edge of Tx Disable until auto-negotiation starts.
7. Not used in the 1000BASE-T module



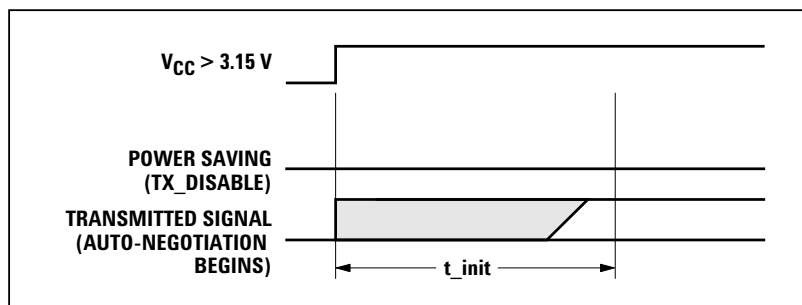

**$t_{init}$ : MODULE HOT-PLUGGED OR VOLTAGE APPLIED AFTER INSERTION, WHEN TX\_DISABLE IS NEGATED**

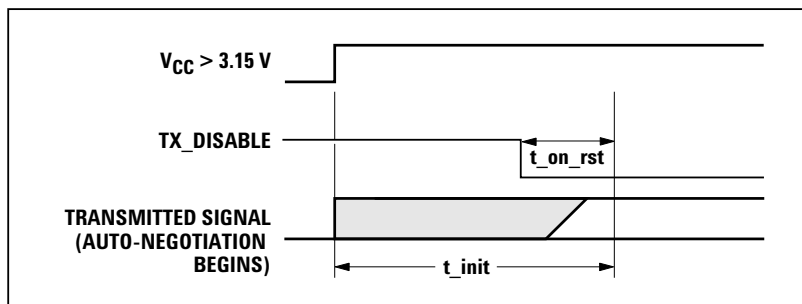

**$t_{init}$ : VOLTAGE APPLIED WHEN TX\_DISABLE IS ASSERTED**

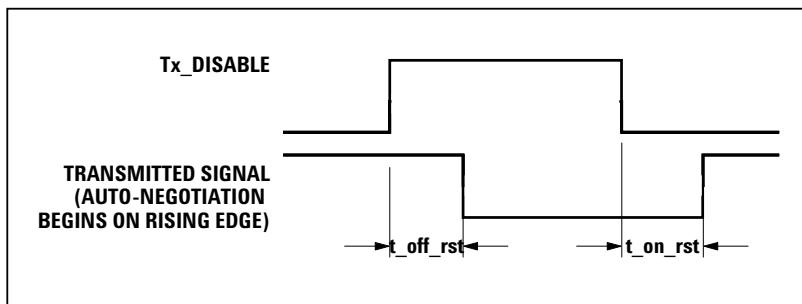

**$t_{off\_rst}$  &  $t_{on\_rst}$ : TX\_DISABLE (RESET) ASSERTED THEN DE-ASSERTED**

**Figure 6. Transceiver Timing Diagrams (Module Installed Except Where Noted)**

**Table 3. EEPROM Serial ID Memory Contents at address A0**

Addr	Hex	ASCII	Addr	Hex	ASCII	Addr	Hex	ASCII	Addr	Hex	ASCII
0	03		40	41	A	68	Note 3		96	Note 5	
1	04		41	42	B	69	Note 3		97	Note 5	
2	00		42	43	C	70	Note 3		98	Note 5	
3	00		43	55	U	71	Note 3		99	Note 5	
4	00		44	2D	-	72	Note 3		100	Note 5	
5	00		45	35	5	73	Note 3		101	Note 5	
6	08		46	37	7	74	Note 3		102	Note 5	
7	00		47	Note 1		75	Note 3		103	Note 5	
8	00		48	30	0	76	Note 3		104	Note 5	
9	00		49	52	R	77	Note 3		105	Note 5	
10	00		50	5A	Z	78	Note 3		106	Note 5	
11	01		51	20		79	Note 3		107	Note 5	
12	0D		52	20		80	Note 3		108	Note 5	
13	00		53	20		81	Note 3		109	Note 5	
14	00		54	20		82	Note 3		110	Note 5	
15	00		55	20		83	Note 3		111	Note 5	
16	00		56	20		84	Note 4		112	Note 5	
17	00		57	20		85	Note 4		113	Note 5	
18	64		58	20		86	Note 4		114	Note 5	
19	00		59	20		87	Note 4		115	Note 5	
20	41	A	60	00		88	Note 4		116	Note 5	
21	56	V	61	00		89	Note 4		117	Note 5	
22	41	A	62	00		90	Note 4		118	Note 5	
23	47	G	63	Note 2		91	Note 4		119	Note 5	
24	4F	O	64	00		92	00		120	Note 5	
25	20		65	10		93	00		121	Note 5	
26	20		66	00		94	00		122	Note 5	
27	20		67	00		95	Note 2		123	Note 5	
28	20								124	Note 5	
29	20								125	Note 5	
30	20								126	Note 5	
31	20								127	Note 5	
32	20										
33	20										
34	20										
35	20										
36	01										
37	00										
38	17										
39	6A										

**Notes:**

1. For ABCU-5700RZ, Address 47 is ASCII 0 (30h). For ABCU-5710RZ, Address 47 is ASCII 1 (31h).
2. Addresses 63 and 95 are check sums. Address 63 is the check sum for bytes 0-62 and address 95 is the check sum for bytes 64-94.
3. Address 68-83 specify a unique identifier.
4. Address 84-91 specify the date code.
5. These fields are reserved for optional use by Avago Technologies.

## Internal ASIC Registers

The ASIC (or “PHY”, for Physical Layer IC) in the transceiver module contains 32 registers. Each register contains 16 bits. The registers are summarized in table 11 and detailed in table 12 through 28. Each bit is either Read Only (RO) or Read/Write (R/W). Some bits are also described as Latch High (LH) or Latch Low (LL) and/or Self Clearing (SC).

The registers are accessible through the 2-wire serial CMOS EEPROM protocol of the ATMEL AT24C01A or equivalent. The address of the PHY is 1010110x, where x is the R/W bit. Each register’s address is 000yyyyy, where yyyyy is the binary equivalent of the register number. Write and read operations must send or receive 16 bits of data, so the “multi-page” access protocol must be used.

**Table 4. Summary of Internal IC Registers**

Register	Description
0	Control
1	Status
2-3	N/A for SFP Module
4	Auto-Negotiation Advertisement
5	Auto-Negotiation Link Partner Ability
6	Auto-Negotiation Expansion
7	Auto-Negotiation Next Page Transmit
8	Auto-Negotiation Link Partner Received Next Page
9	MASTER-SLAVE Control Register
10	MASTER-SLAVE Status Register
11-15	N/A for SFP Module
16	Extended Control 1
17	Extended Status 1
18-19	N/A for SFP Module
20	Extended Control 2
21	Receive Error Counter
22	Cable Diagnostic 1
23-25	N/A for SFP Module
26	Extended Control 3
27	Extended Status 2
28	Cable Diagnostic 2
29-31	N/A for SFP Module

**Table 5. Register 0 (Control)**

<b>Bit</b>	<b>Name</b>	<b>Description</b>	<b>Hardware Reset</b>	<b>Software Reset</b>	<b>Details</b>
0.15 R/W	Reset	1 = PHY reset 0 = Normal Operation	0	self-clearing	Performs software reset
0.14 R/W	Loopback	1 = Enable 0 = Disable	0	0	Serial data in on RD+/- is deserialized, then reserialized and sent out on TD+/-
0.13 R/W	Speed Selection (LSB)	0 = 1000 Mb/s	0	Update	Paired with bit 0.6. Other settings indicate different speeds, but the module will not function at speeds other than 1000 Mb/s. This bit is only meaningful if bit 0.12 is 0.
0.12 R/W	Auto-Negotiation Enable	1 = Enable 0 = Disable	1	Update	Changes to this bit take effect after software reset.
0.11 R/W	Power Down	1 = Power Down 0 = Normal Operation	0	0	
0.10 R/W	Isolate	1 = Isolate 0 = Normal Operation	0	0	
0.9 R/W/SC	Restart Auto-Negotiation	1 = Restart Auto-Negotiation Process 0 = normal operation	0	Self-clearing	
0.8 R/W	Duplex Mode	1 = Full Duplex 0 = Half Duplex	1	Update	This bit is only meaningful if 0.12 is 0.
0.7 R/W	Collision Test	1 = enable COL signal test 0 = disable COL signal test	0	0	
0.6 R/W	Speed Selection (MSB)	1 = 1000 Mb/s	1	Update	Paired with bit 0.13. Other settings indicate different speeds, but the module will not function at speeds other than 1000 Mb/s. This bit is only meaningful if bit 0.12 is 0.
0.5:0 R/W	N/A to SFP Module		000000	000000	

**Table 6. Register 1 (Status)**

Bit	Name	Description	Hardware Reset	Software Reset	Details
1.15:9 RO	N/A to SFP Module		0000000	0000000	
1.8 RO	Extended Status	1 = Extended status information in register 15	1	1	Always 1
1.7 RO	N/A to SFP Module		0	0	
1.6 RO	MF Preamble Suppression	1 = PHY will accept management frames with preamble suppressed.	1	1	Always 1
1.5 RO	Auto-Negotiation Complete	1 = Auto-Negotiation Process Completed 0 = Auto-Negotiation Process Not Completed	0	0	
1.4 RO/LH	Remote Fault	1 = remote fault condition detected 0 = no remote fault condition detected	0	0	
1.3 RO	Auto-Negotiation Ability	1 = module is able to perform Auto-Negotiation 0 = module is unable to perform Auto-Negotiation	1	1	
1.2 RO/LL	Link Status	1 = link is up 0 = link is down	0	0	
1.1 RO/LH	Jabber Detect	1 = jabber condition detected 2 = no jabber condition detected	0	0	
1.0 RO	Extended Capability	1 = extended register capabilities	1	1	Always 1

**Table 7. Register 4 (Auto-Negotiation Advertisement)**

<b>Bit</b>	<b>Name</b>	<b>Description</b>	<b>Hardware Reset</b>	<b>Software Reset</b>	<b>Details</b>
4.15:14 R/W	N/A to SFP Module		10	10	When writing to register 4, be sure to preserve the values of these bits. Changes to these values can interrupt the normal operation of the SFP module.
4.13 R/W	Remote Fault	1 = Remote fault bit is set 2 = No remote fault	0	Retain	This bit takes effect after auto-negotiation is restarted, either via bit 0.9 or because the link goes down.
4.12 R/W	N/A to SFP Module		0	Retain	
4.11:10 R/W	PAUSE Encoding	11 = Both Asymmetric PAUSE and Symmetric PAUSE toward local device 10 = Asymmetric PAUSE toward link partner 01 = Symmetric PAUSE 00 = No PAUSE	00	Retain	This bit takes effect after auto-negotiation is restarted, either via bit 0.9 or because the link goes down.
4.9:5 R/W	N/A to SFP Module		00000	00000	
4.4:0 RO	IEEE 802.3 Selector Field		00001	00001	Set per IEEE standard.

**Table 8. Register 5 (Auto-Negotiation Link Partner Ability)**

Bit	Name	Description	Hardware Reset	Software Reset	Details
5.15 RO	Next Page	1 = Link partner advertises next page ability 0 = Link partner does not advertise next page ability	0	0	
5.14 RO	Acknowledge	1 = Link partner acknowledges receiving link code word from module 0 = Link partner does not acknowledge receiving link code word from module	0	0	
5.13 RO	Remote Fault	1 = Link partner has a remote fault 0 = Link partner does not have a remote fault	0	0	
5.12 RO	N/A to SFP Module		0	0	
5.11:10 RO	PAUSE Encoding	11 = Asymmetric PAUSE and Symmetric PAUSE toward local device 10 = Asymmetric PAUSE toward link partner 01 = Symmetric PAUSE 00 = No PAUSE	00	00	
5.9:5 RO	N/A to SFP Module		00000	00000	
5.4:0 RO	IEEE 802.3 Selector Field		00000	00000	Set per IEEE standard.

**Table 9. Register 6 (Auto-Negotiation Expansion)**

Bit	Name	Description	Hardware Reset	Software Reset	Details
6.15:5 RO	N/A to SFP Module		00000000000	00000000000	
6.4 RO	Parallel Detection Fault	1 = A fault has been detected via the Parallel Detection function 0 = A fault has not been detected via the Parallel Detection function	0	0	This register is not valid until auto-negotiation is complete, as indicated by bit 1.5.
6.3 RO	Link Partner Next Page Able	1 = Link partner is next page able 0 = Link partner is not next page able	0	0	See note in bit 6.4.
6.2 RO	Next Page Able	1 = Local device is next page able 0 = Local device is not next page able	1	1	See note in bit 6.4.
6.1 RO/LH	Page Received	1 = A new page has been received 0 = A new page has not been received	0	0	See note in bit 6.4.
6.0 RO	Link Partner Auto-Negotiation Able	1 = Link partner is auto-negotiation able 0 = Link partner is not auto-negotiation able	0	0	See note in bit 6.4.

**Table 10. Register 7 (Auto-Negotiation Next Page Transmit Register)**

Bit	Name	Description	Hardware Reset	Software Reset	Details
7.15 R/W	Next Page	1 = Additional next pages to follow 0 = Last page	0	0	
7.14 RO	N/A to SFP Module		0	0	
7.13 R/W	Message Page	1 = Message page 0 = Unformatted page	1	1	
7.12 R/W	Acknowledge 2	1 = Will comply with message 0 = Will not comply with message	0	0	
7.11 RO	Toggle	1 = previous value of the toggle bit was 0 0 = previous value of the toggle bit was 1	0	0	
7.10:0 R/W	Message/Unformatted Code Field		00000000001	00000000001	

**Table 11. Register 8 (Auto-Negotiation Link Partner Received Next Page)**

Bit	Name	Description	Hardware Reset	Software Reset	Details
8.15 RO	Next Page	1 = Additional next pages to follow 0 = Last page	0	0	
8.14 RO	Acknowledge		0	0	
8.13 RO	Message Page	1 = Message page 0 = Unformatted page	0	0	
8.12 RO	Acknowledge 2	1 = Will comply with message 0 = Will not comply with message	0	0	
8.11 RO	Toggle	1 = previous value of the toggle bit was 0 0 = previous value of the toggle bit was 1	0	0	
8.10:0 RO	Message/Unformatted Code Field		00000000000	00000000000	



**Table 12. Register 9 (MASTER-SLAVE Control)**

Bit	Name	Description	Hardware Reset	Software Reset	Details
9.15:13 R/W	Transmitter Test Mode	000 = Normal Operation 001 = Transmit Waveform Test 010 = Transmit Jitter Test in MASTER Mode 011 = Transmit Jitter Test in SLAVE Mode	000	000	The module enters test modes when MDI crossover is first disabled via bits 16.6:5.
9.12 R/W	MASTER-SLAVE Manual Config Enable	1 = Enable MASTER-SLAVE Manual configuration value in register 9.11 2 = Disable MASTER-SLAVE Manual configuration value in register 9.11	0	Retain	This bit takes effect after auto-negotiation is restarted via bit 0.9.
9.11 R/W	MASTER-SLAVE Config Value	1 = Configure PHY as MASTER during MASTER-SLAVE negotiation 0 = Configure PHY as SLAVE during MASTER-SLAVE negotiation	1	Retain	This bit takes effect after auto-negotiation is restarted via bit 0.9. This bit is ignored unless bit 9.12 is 1.
9.10 R/W	Port Type	1 = Prefer PHY as MASTER (multiport) 0 = Prefer PHY as SLAVE (single port)	1	Retain	This bit takes effect after auto-negotiation is restarted via bit 0.9. This bit is ignored unless bit 9.12 is 0.
9.9 R/W	1000BASE-T Full Duplex	1 = Advertise PHY is 1000BASE-T full duplex capable 0 = Advertise PHY is not 1000BASE-T full duplex capable	1	Retain	This bit takes effect after auto-negotiation is restarted via bit 0.9.
9.8 R/W	1000BASE-T Half Duplex	1 = Advertise PHY is 1000BASE-T half duplex capable 0 = Advertise PHY is not 1000BASE-T half duplex capable	0	Retain	This bit takes effect after auto-negotiation is restarted via bit 0.9.
9.7:0 RO	N/A to SFP Module		00000000	00000000	

**Table 13. Register 10 (MASTER-SLAVE Status)**

Bit	Name	Description	Hardware Reset	Software Reset	Details
10.15 RO/LH/SC	MASTER-SLAVE Configuration Fault	1 = MASTER-SLAVE configuration fault detected 0 = No MASTER-SLAVE configuration fault detected	0	0	This bit is cleared each time that this register is read. This bit clears on Auto-Negotiation enable or Auto-Negotiation complete. This bit is set if the number of failed MASTER-SLAVE resolutions reaches 7. This bit is set if both PHY's are forced to MASTER's or SLAVE's at the same time using bits 9.12 and 9.11.
10.14 RO	MASTER-SLAVE Configuration Resolution	1 = Local PHY configuration resolved to MASTER 2 = Local PHY configuration resolved to SLAVE	0	0	
10.13 RO	Local Receiver Status	1 = Local Receiver OK 0 = Local Receiver not OK	0	0	
10.12 RO	Remote Receiver Status	1 = Remote Receiver OK 0 = Remote Receiver not OK	0	0	
10.11 RO	Link Partner Full Duplex	1 = Link Partner is capable of 1000BASE-T full duplex 0 = Link Partner is not capable of 1000BASE-T full duplex	0	0	This bit is valid only when the Page Received bit (6.1) is set to 1.
10.10 RO	Link Partner Half Duplex	1 = Link Partner is capable of 1000BASE-T half duplex 0 = Link Partner is not capable of 1000BASE-T half duplex	0	0	This bit is valid only when the Page Received bit (6.1) is set to 1.
10.9:8	N/A to SFP Module		00	00	
10.7:0 RO/SC	Idle Error Count	Counts errors when receiving idle patterns.	00000000	00000000	These bits do not roll-over when they are all one's.

**Table 14. Register 16 (Extended Control 1)**

<b>Bit</b>	<b>Name</b>	<b>Description</b>	<b>Hardware Reset</b>	<b>Software Reset</b>	<b>Details</b>
16.15:7 R/W	N/A to SFP Module		00000000	Retain (15:10, 7) or Update (9:8)	When writing to register 16, be sure to preserve the values of these bits. Changes to these values can interrupt the normal operation of the SFP module.
16.6:5 R/W	MDI Crossover Mode	00 = Manual MDI configuration 01 = Manual MDIX configuration 10 = N/A to SFP module 11 = Enable automatic crossover	11	Update	Changes to this bit take effect after software reset.
16.4:0 R/W	N/A to SFP Module		11000	Retain (2:0) or Update (4:3)	When writing to register 16, be sure to preserve the values of these bits. Changes to these values can interrupt the normal operation of the SFP module.

**Table 15. Register 17 (Extended Status 1)**

Bit	Name	Description	Hardware Reset	Software Reset	Details
17.15:14 RO	Speed	10 = 1000 Mbps	0	Retain	This bit is only valid after bit 17.11 is set.
17.13 RO	Duplex	1 = Full duplex 0 = Half duplex	0	Retain	This bit is only valid after bit 17.11 is set.
17.12 RO/LH	Page Received	1 = Page received 0 = Page not received	0	0	
17.11 RO	Speed and Duplex Resolved	1 = Resolved 0 = Speed not resolved	0	0	This bit is set when auto-negotiation is either completed or disabled.
17.10 RO	Link	1 = Link up 0 = Link down	0	0	
17.9:7 RO	Cable Length	000 = < 50 m 001 = 50 - 80 m 010 = 80 - 110 m 011 = 110 - 140 m 100 = > 140 m	000	000	
17.6 RO	MDI Crossover Status	1 = Crossover 0 = No crossover	0	0	Crossover means that pairs A+/- (pins 1 & 2 on the RJ45 jack) and B+/- (pins 3 & 6) are interchanged and C+/- (pins 4 & 5) and D+/- (pins 7 & 8) are interchanged. This bit is only valid after bit 17.11 is set.
17.5:4 RO	N/A to SFP Module		00	00	
17.3 RO	MAC Transmit Pause Enabled	1 = Transmit pause enabled 2 = Transmit pause disabled	0	0	This bit reflects the capability of the MAC to which the module is connected on the serial side. This bit is only valid after bit 17.11 is set.
17.2 RO	MAC Receive Pause Enabled	1 = Receive pause enabled 2 = Receive pause disabled	0	0	This bit reflects the capability of the MAC to which the module is connected on the serial side. This bit is only valid after bit 17.11 is set.
17.1 RO	Polarity	1 = Polarity reversed 2 = Polarity not reversed	0	0	This bit is set if any of the four twisted pairs have the + and - wires reversed.
17.0 RO	Jabber	1 = Jabber detected 0 = No jabber detected	0		

**Table 16. Register 20 (Extended Control 2)**

Bit	Name	Description	Hardware Reset	Software Reset	Details
20.15 RO	Link down on no idles	1 = Link lock lost 0 = Link lock intact	0	0	If idle patterns are not seen within 1 ms, link lock is lost and link is brought down.
20.14:4 R/W	N/A to SFP Module		00011000110	0001100110	When writing to register 20, be sure to preserve the values of these bits. Changes to these values can interrupt the normal operation of the SFP module.
20.3 R/W	Clause 37 Auto-Negotiation Enable	0 = Disable BASE-X auto-negotiation 1 = Enable BASE-X auto-negotiation	1	Update	Changes to this bit take effect after software reset.
20.2:0 R/W	N/A to SFP Module		000	000	When writing to register 20, be sure to preserve the values of these bits. Changes to these values can interrupt the normal operation of the SFP module.

**Table 17. Register 21 (Receive Error Counter)**

Bit	Name	Description	Hardware Reset	Software Reset	Details
21.15:0 RO/SC	Receive errors	Counts errors received on the 1000BASE-T side	0	0	These bits do not roll-over when they are all one's.

**Table 18. Register 22 (Cable Diagnostic 1)**

Bit	Name	Description	Hardware Reset	Software Reset	Details
22.15:2 RO	N/A to SFP Module				
22.1:0 R/W	MDI Pair Select	00 = Pins 1 & 2 (Channel A) 01 = Pins 3 & 6 (Channel B) 10 = Pins 4 & 5 (Channel C) 11 = Pins 7 & 8 (Channel D)			For VCT results, choose the twisted pair on which register 28 will display.

**Table 19. Register 26 (Extended Control 3)**

Bit	Name	Description	Hardware Reset	Software Reset	Details
26.15:8 RO	N/A to SFP Module		00000000	Retain	
26.7:3 R/W	N/A to SFP Module		00001	Update	When writing to register 26, be sure to preserve the values of these bits. Changes to these values can interrupt the normal operation of the SFP module.
26.2:0 R/W	RD+/- Output Amplitude	000 = 0.50 V 001 = 0.55 V 010 = 0.60 V 011 = 0.65 V 100 = 0.70 V 101 = 0.75 V 110 = 0.80 V 111 = 0.85 V	010	Retain	All voltages measured peak-to-peak into a 100-ohm load.

**Table 20. Register 27 (Extended Status 2)**

Bit	Name	Description	Hardware Reset	Software Reset	Details
27.15:13 RO/SC	N/A to SFP Module		100	Update (27.15), Retain (27.14:13)	When writing to register 27, be sure to preserve the values of these bits. Changes to these values can interrupt the normal operation of the SFP module.
27.12 R/W	1000BASE-X Auto-negotiation Bypass Enable	1 = Enabled 0 = Disabled	1	Update	If enabled, BASE-X link will come up after 200 ms even if BASE-X auto-negotiation fails. When writing to register 27, be sure to preserve the values of this bit. Changes to this value can interrupt the normal operation of the SFP module.
27.11 RO	1000BASE-X Auto-negotiation Bypass Status	1 = BASE-X auto-negotiation failed and BASE-X link came up because bypass mode timer expired 0 = BASE-X link came up because regular BASE-X auto-negotiation was completed	0	Retain	See bit 27.12.
27.10:0 R/W	N/A to SFP Module		0000001000	Update	When writing to register 27, be sure to preserve the values of these bits. Changes to these values can interrupt the normal operation of the SFP module.

**Table 21. Register 28 (Cable Diagnostic 2)**

<b>Bit</b>	<b>Name</b>	<b>Description</b>	<b>Hardware Reset</b>	<b>Software Reset</b>	<b>Details</b>
28.15 R/W	Enable Cable Diagnostic Test	1 = Enable test 0 = disable test	0	0	The test can only be performed when the link is down. If the link partner is trying to auto-negotiate or if the link partner is sending out idle link pulses, the test will proceed.
28.14:13 RO	Status	11 = Test fail 10 = Open detected in twisted pair 01 = Short detected in twisted pair 00 = No short or open detected in twisted pair	00	00	The twisted pair under test is specified in register 22.
28.12:8 RO	Reflected Magnitude	11111 = 1 V 10000 = 0 V 00000 = -1 V	00000	00000	The twisted pair under test is specified in register 22.
28.7:0 RO	Distance	Distance to the short or open	00000000	00000000	The distance is given in meters by $13/16 * (\text{decimal equivalent of } 28.7:0) + 32$ . The twisted pair under test is specified in register 22. If no short or open is detected, these bits are 0's.

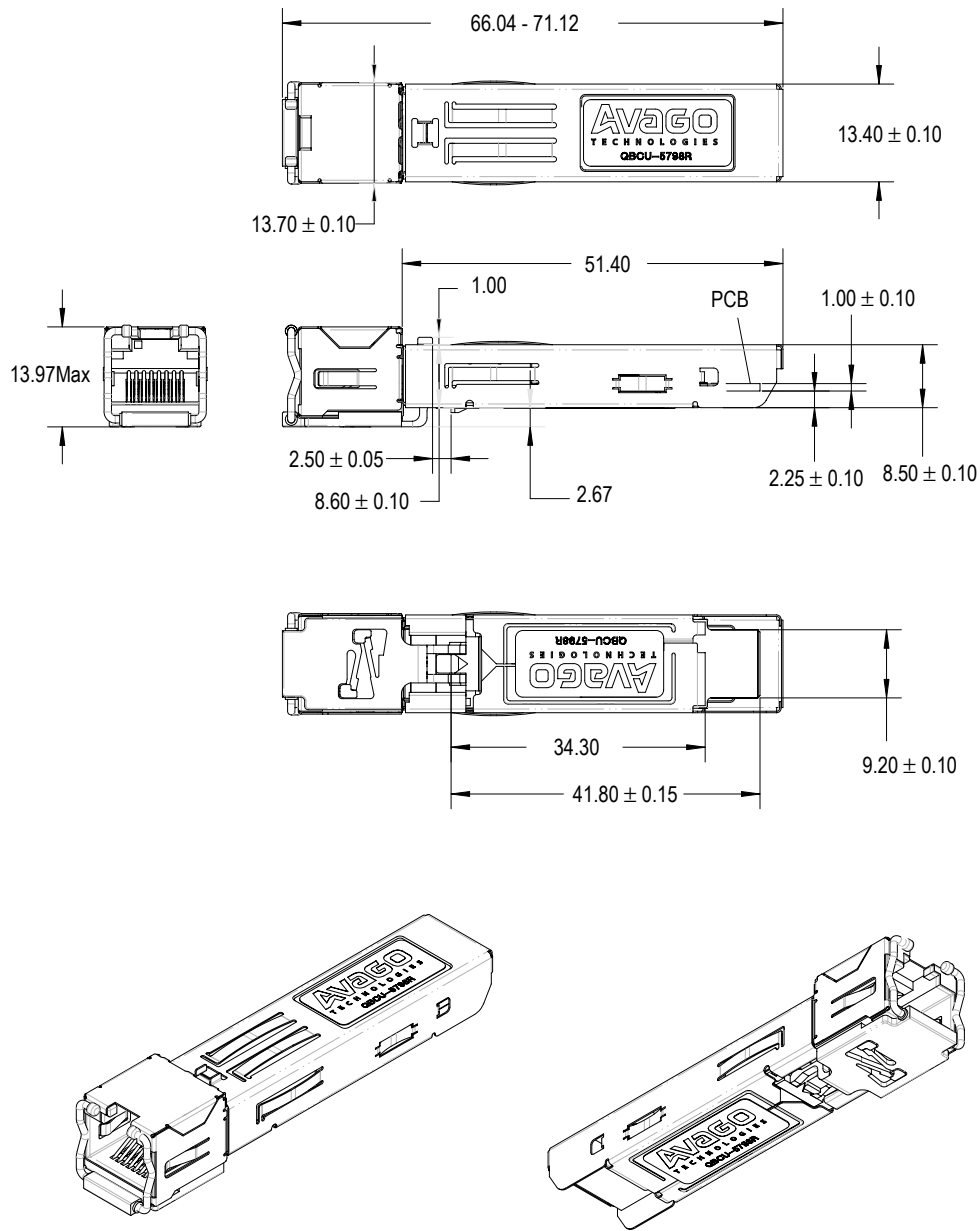
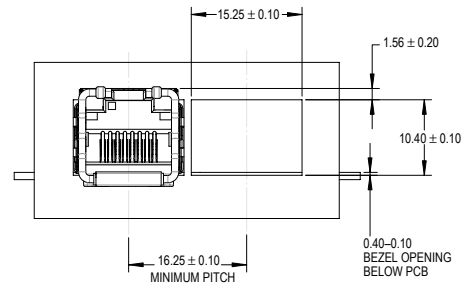
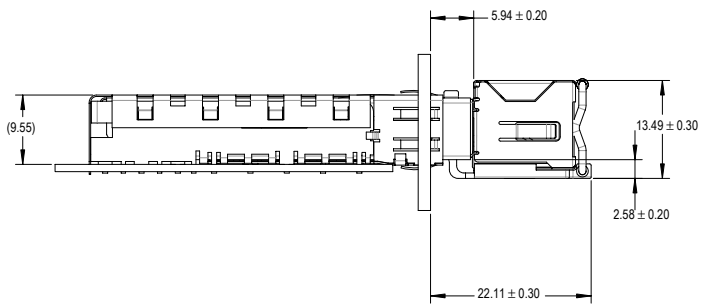
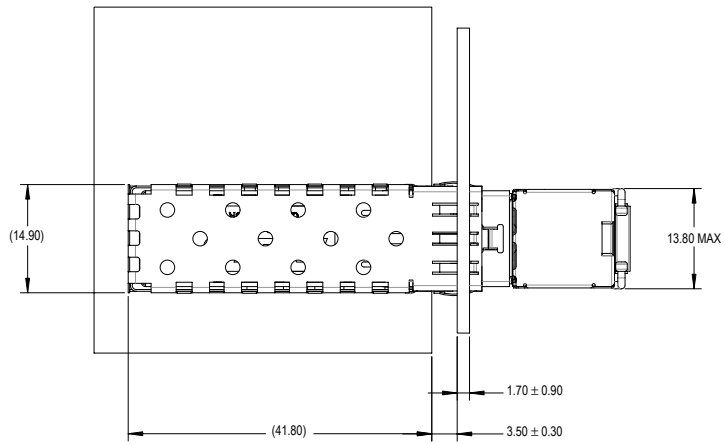

Figure 7a. Module Drawing





SFP MSA RECOMMENDED BEZEL

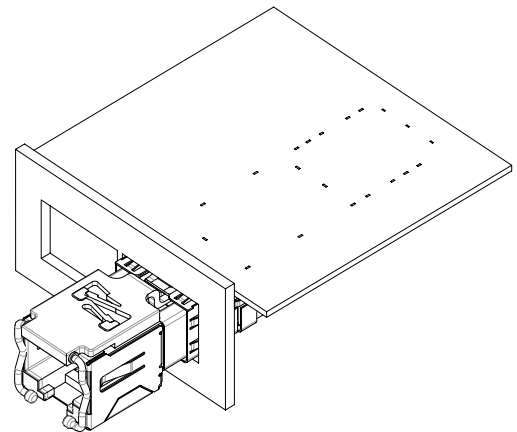
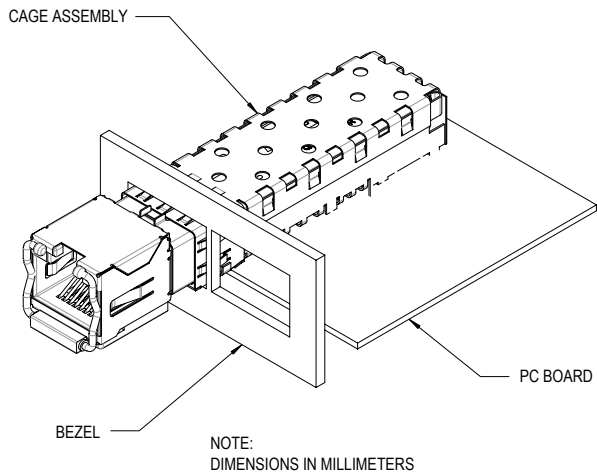
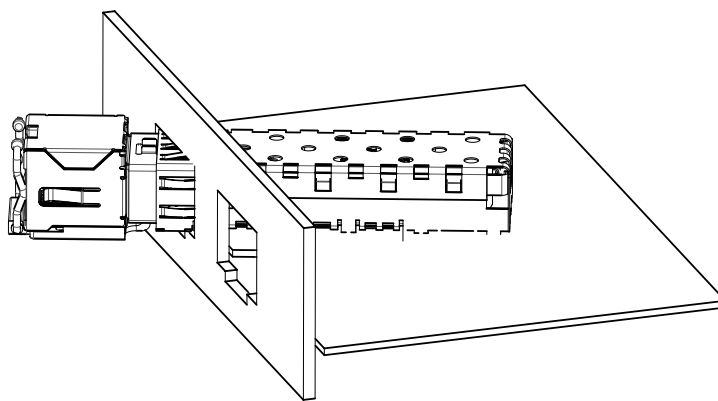
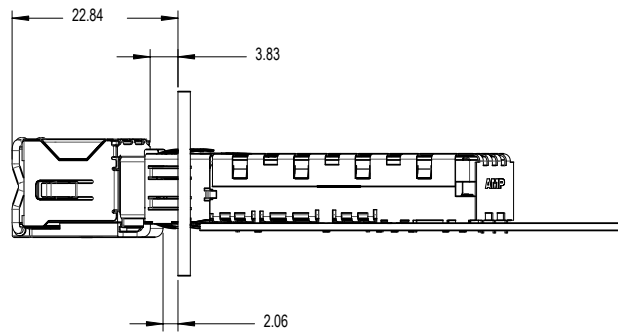
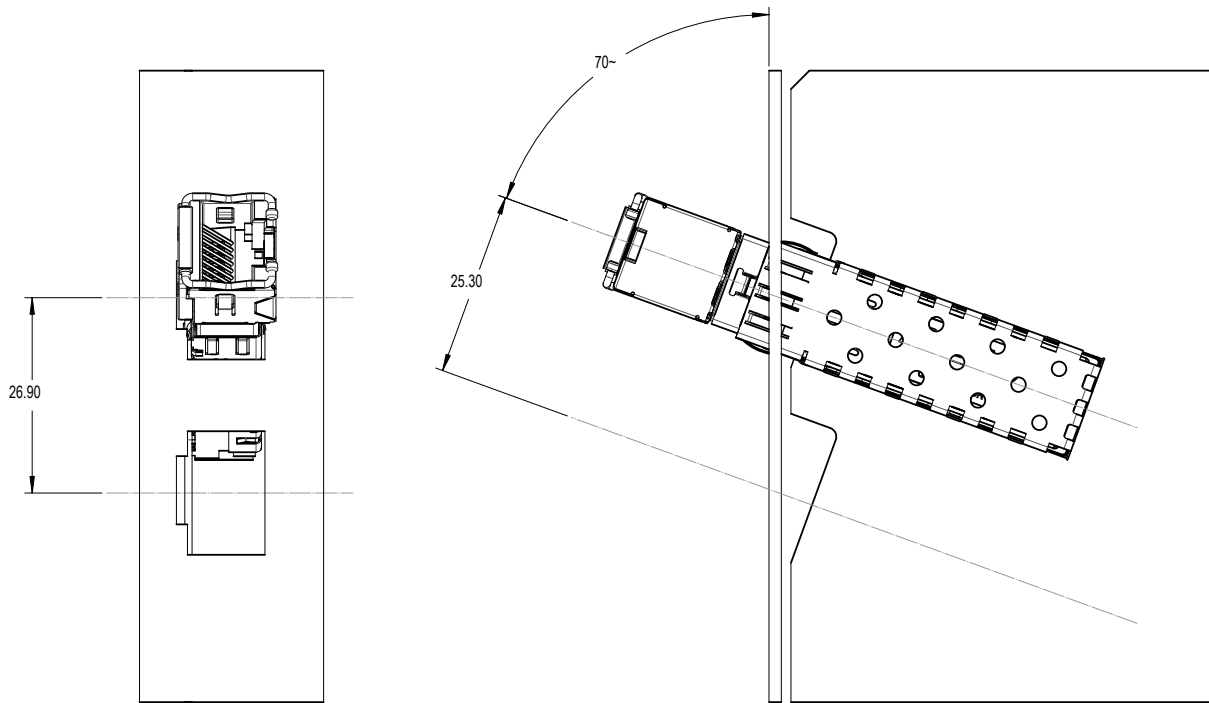

Figure 7b. Assembly Drawing



NOTE:  
DIMENSIONS IN MILLIMETERS

**Figure 7c. Angled Application**

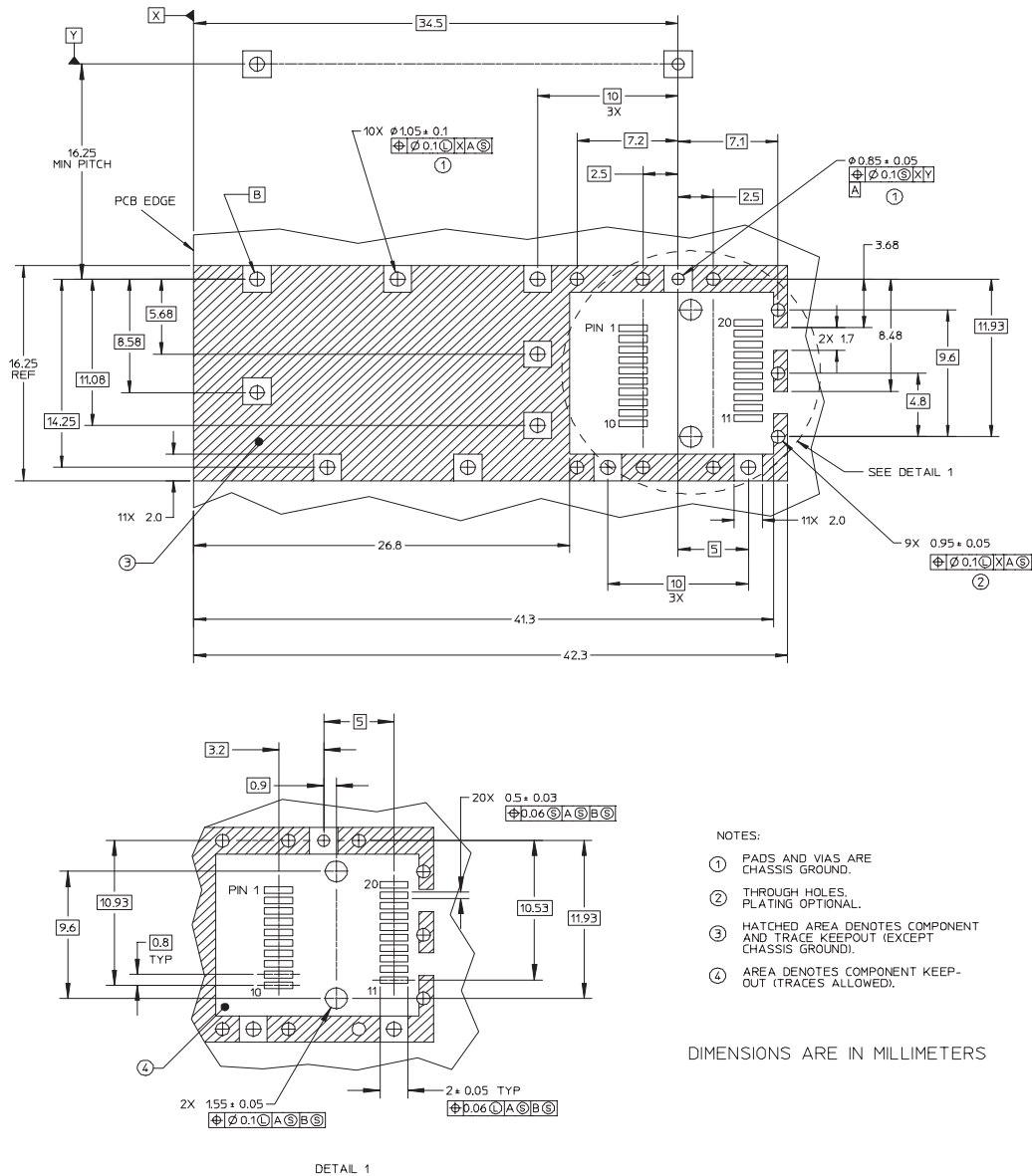

Figure 7d. SFP Host Board Mechanical Layout

For product information and a complete list of distributors, please go to our web site: [www.avagotech.com](http://www.avagotech.com)

Avago, Avago Technologies, and the A logo are trademarks of Avago Technologies, Limited in the United States and other countries.  
Data subject to change. Copyright © 2006 Avago Technologies Limited. All rights reserved. Obsoletes AV01-0165EN  
AV02-0223EN - April 20, 2007

