

M0220MD-202LDAR2

Vacuum Fluorescent Display Module

RoHS Compliant

Newhaven Display International, Inc.

2511 Technology Drive, Suite 101

Elgin IL, 60124

Ph: 847-844-8795

Fax: 847-844-8796

www.newhavendisplay.com

nhtech@newhavendisplay.com

nhsales@newhavendisplay.com

STANDARD NAME		DOCUMENT NO.	REV. NO	PAGE
			00	

1. SCOPE

This specification applies to VFD module

2. FEATURES

- 2.1 Since a DC/DC converter is used, only +5Vdc power source is required to operate the module.
- 2.2 High quality blue-green(505 nm) vacuum fluorescent display provides an attractive and readable medium. Other colors can be achieved by simple wavelength filters.
- 2.3 Characters are provided with a 5*7 dot matrix.

3. GENERAL DESCRIPTIONS

- 3.1 This specification becomes effective after being approved by the purchaser.
- 3.2 When any conflict is found in the specification, appropriate action shall be taken upon agreement of both parties.
- 3.3 The expected necessary service parts should be arranged by the customer before the completion of production.

4. PRODUCT SPECIFICATIONS

4.1 Type

Table_1

Digit Format	5*7 Dot Matrix with Descriptor
--------------	--------------------------------

4.2 Outer Dimensions, Weight (See Fig_4 on page 5/11 for details)

Table_2

Parameter		Specification	Unit
Outer Dimensions	Width	193.0±1.0	mm
	Height	64.0±1.0	mm
	Thickness	25.0 Max	mm
Weight		Typical 220	g

STANDARD NAME		DOCUMENT NO.	REV.NO	PAGE
			00	

4.3 Specifications of the Display Panel

Table_3

Parameter	Specification	Unit
Display Size (W*H)	146.1*29.0	mm
Number of Digit	20 Digits*2 Rows	--
Character Size (W*H)	5.5*10.5	mm
Character Pitch	Horizontal	7.4
	Vertical	15.5
Display Color	Blue-Green(505 nm)	

4.4 Environment Conditions

Table_4

Parameter	Symbol	Min.	Max.	Unit
Operating Temperature	Topr	-40	+85	°C
Storage Temperature	Tstg	-50	+95	°C
Humidity (Operating)	Hopr	0	85	%
Humidity(Non-operating)	Hstg	0	90	%
Vibration (10 ~ 55 Hz)	--	--	4	G
Shock	--	--	40	G

4.5 Absolute Maximum Ratings

Table_5

Parameter	Symbol	Min.	Max.	Unit
Supply Voltage	Vcc	-0.3	5.5	Vdc
Input Signal Voltage	Vis	-0.3	5.5	Vdc

4.6 Recommend Operating Conditions

Table_6

Parameter	Symbol	Min.	Typ.	Max.	Unit
Supply Voltage	Vcc	4.5	5.0	5.5	Vdc
H-Level Input Voltage	Vih	3.5	--	5.5	Vdc
L-Level Input Voltage	Vil	--	--	1.5	Vdc

4.7 DC Characteristics(Ta=+25 °C,Vcc=+5.0Vdc)

Table_7

Parameter	Symbol	Min.	Typ.	Max.	Unit
Supply Current ※)	Icc	--	800	1,200	mA
H-Level Input Current	Iih	-1.0	--	1.0	μ A
L-Level Input Current	Iil	-1.0	--	1.0	μ A
Luminance	L	100	200	--	Ft-L

※)The surge current can be approx.3 times the specified supply current at power on .

4.8 AC Characteristics (Ta=+25°C, Vcc=+5.0Vdc)

Table 8

Parameter	Symbol	Min.	TYP.	Max.	Unit
CLK-DOUT Delay Time	t _{PD}	--	--	300	ns
Delay Time Low to High	t _{DLH}	--	0.3	1.0	μs
Transit Time Low to High	t _{TLH}	--	2.0	5.0	μs
Delay time high to Low	t _{DHL}	--	0.3	1.0	μs
Transit Time High to Low	t _{THL}	--	2.0	5.0	μs

4.9 Timing Chart

4.9.1 Data Input Timing

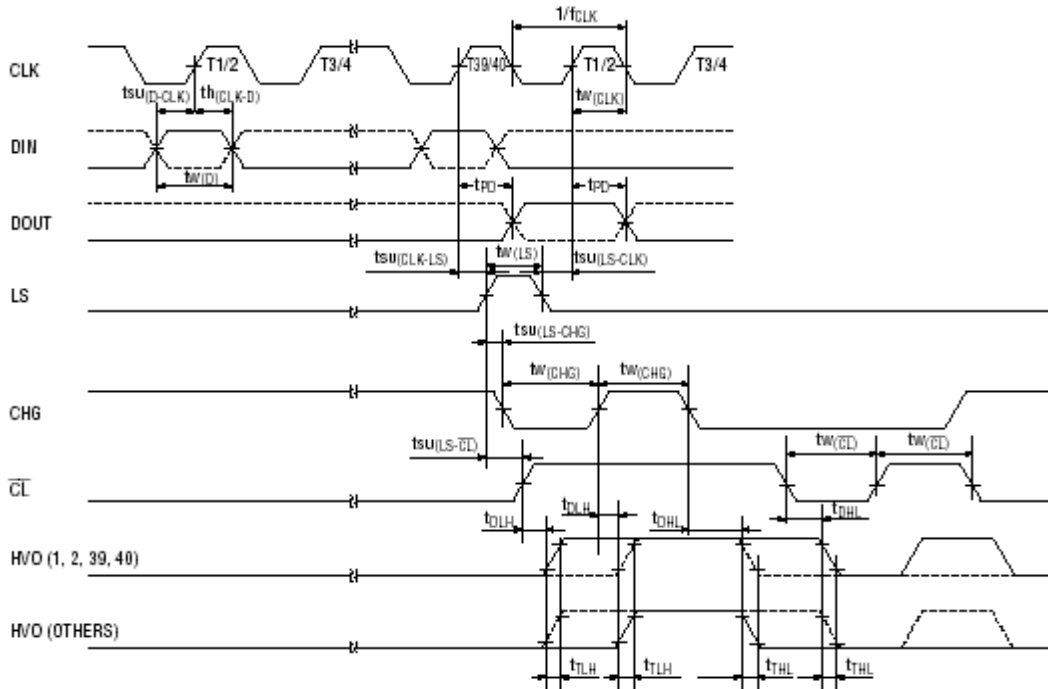

4.10 System Block Diagram

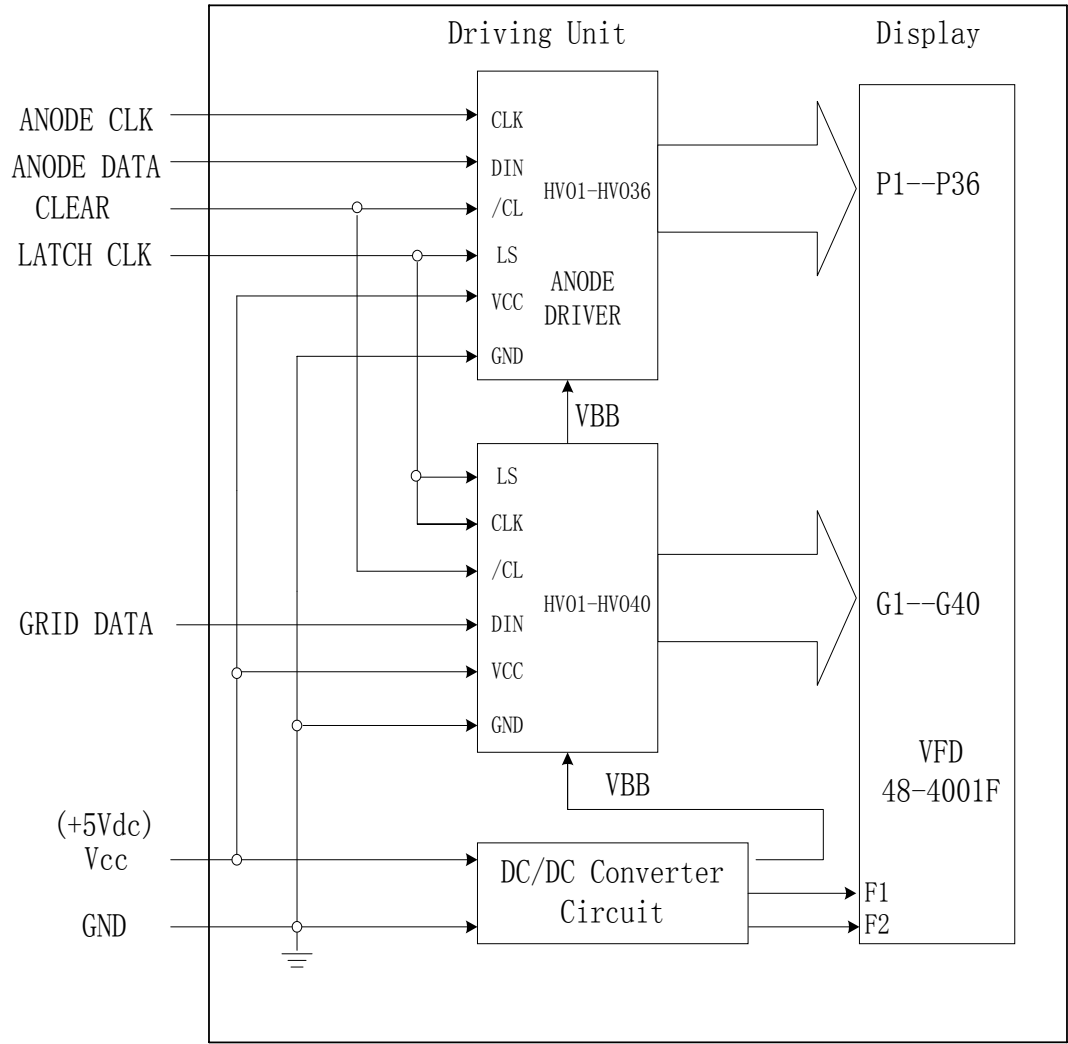

Fig-3. VFD Module System Block Diagram

- 4.11 Outer Dimensions :
- 4.12 Pattern Details :
- 4.13 Signal Interfacing :

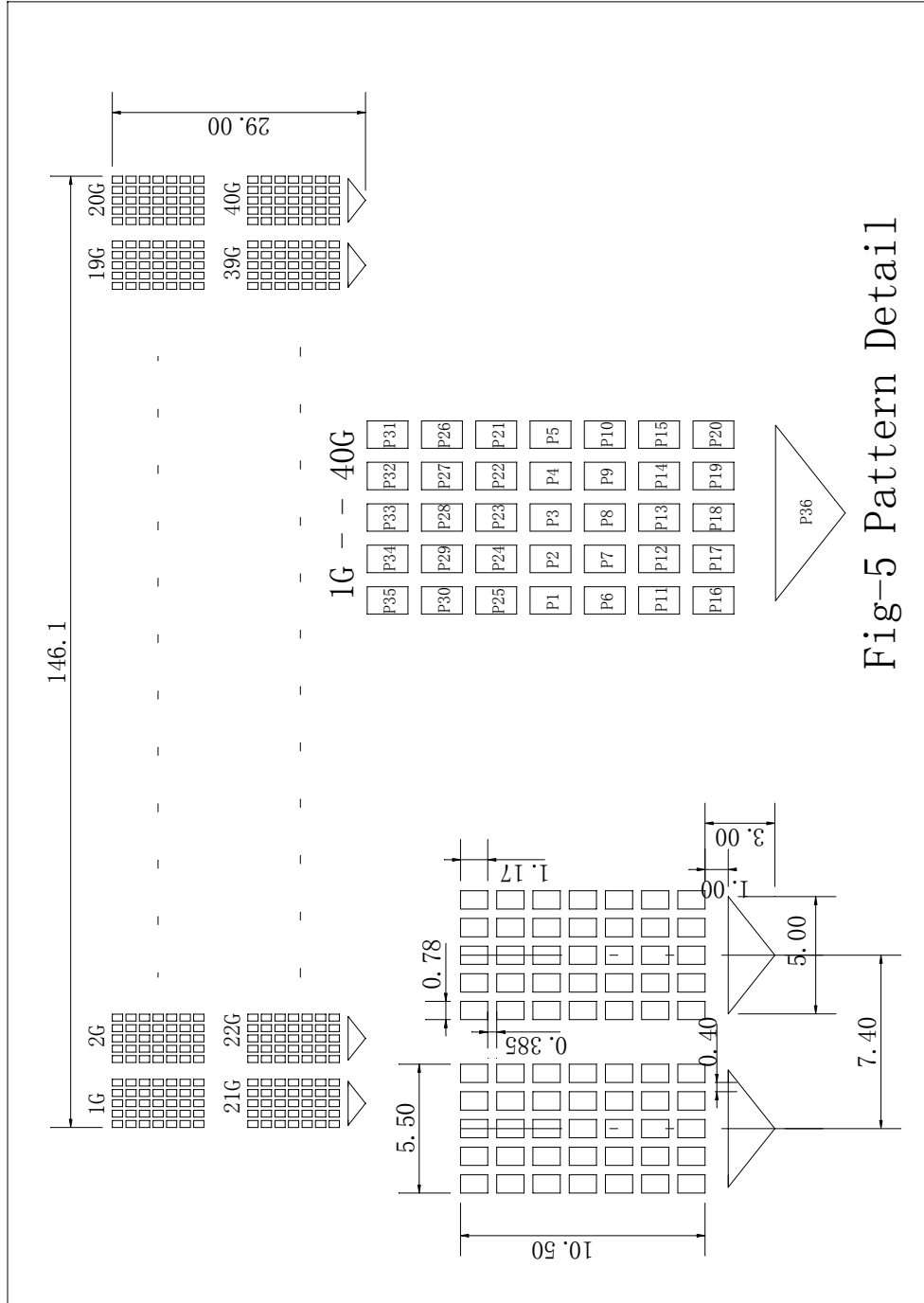

Fig-5 Pattern Detail

STANDARD NAME		DOCUMENT NO.	REV. NO	PAGE
			00	

Signal Interface

- Connector (Female): HIF3B-20D-2.54R (HIROSE) or equivalent
 → Mate Socket (Male) : BH-R20 FG (aster) or equivalent

Table_9

Pin No	Signal	Pin No	Signal
1	Vcc	2	Vcc
3	GND	4	GND
5	ANODE CLK	6	GND
7	GND	8	GND
9	GRID DATA	10	GND
11	CLEAR	12	GND
13	ANODE DATA	14	GND
15	LATCH CLK	16	GND
17	GND	18	GND
19	Vcc	20	Vcc

STANDARD NAME		DOCUMENT NO.	REV. NO	PAGE
			00	

5、 Function Descriptions

The anode and grid data is clocked into the module using a synchronous serial interface. The refresh rate should be at least 60Hz (100Hz IS RECOMMENDED). The sequence That this data should be sent to the module is as follows:

- Clock in the anode data
- Clock in the grid data
- Latch the anode and grid data
- Disable the clear signal
- Enable the clear signal

A minimum of 36 anode data bits should be sent to the module. The table below details the correlation between the anode bits clocked into the module and their Pixel position in the 5X7 characters. The 36th bits is unused in the upper row of characters and is the inverted triangle in the lower row. Additional bits can be clocked into the module if necessary. The module will only display the last 36 data bits. if, for example. 5 complete bytes of data are sent. the triangle will be the last bit of byte 5. and the first 4 bits of byte 1 will not be displayed.

1	2	3	4	5
6	7	8	9	10
11	12	13	14	15
16	17	18	19	20
21	22	23	24	25
26	27	28	29	30
31	32	33	34	35

At any point in time only 1 grid should be active. this active bit can be propagated through the display by clocking in low GRID DATA bits for the other position. For example: send the anode data for character position 1. then clock in a high GRID DATA bit (using the LATCH CLK signal). To display a character at position 2, send the anode data then clk in a low GRID DATA bit. this can be continued to character position 40. The table below details the character position of the VFD.

1 ST	2 ND		19 TH	20 TH
21 ST	22 ND		39 TH	40 TH

STANDARD NAME		DOCUMENT NO.	REV. NO	PAGE
			00	
<p>6、 Operation Recommendations</p> <p>6.1 Avoid applying excessive shock or vibration beyond the specification for the VFD module.</p> <p>6.2 Since VFDs are made of glass material, careful handing is required, i.e. Direct impact with hard material to the glass surface (especially exhaust tip) may crack the glass.</p> <p>6.3 When mounting the VFD module to you system, leave a slight gap between the VFD glass and your front panel. The module should be mounted without stress to avoid flexing of the PCB.</p> <p>6.4 Avoid plugging or unplugging the interface connection with the power on , otherwise it may cause the severe damage to input circuitry.</p> <p>6.5 Slow starting power supply may cause non-operation because the chip mcu won' t be reset.</p> <p>6.6 Exceeding any of maximum ratings may cause the permanent damage.</p> <p>6.7 Since the VFD modules contain high voltage source, careful handing is required while power is on</p> <p>6.8 When the power is turned off, the capacitor does not discharge immediately. So the high voltage applied to VFD must not get in contact with ICs. In other words, short-circuit of mounted component on PCB within 30 seconds after power-off may cause damage the module.</p> <p>6.9 The power supply must be capable of providing at least 3 times the rated current, because the surge current may be 3 times the specified current consumption when the power is turned on.</p> <p>6.10 Avoid using the module where excessive noise interference is expected. Noise may affects the interface signal and causes improper operation. And it is important to keep the length of the interface cable less than 50cm.</p> <p>6.11 Since all VFD modules contain C-MOS ICs, anti_static handling procedures are always required.</p>				

STANDARD NAME		DOCUMENT NO.	REV. NO	PAGE
			00	

7、Reliability Condition

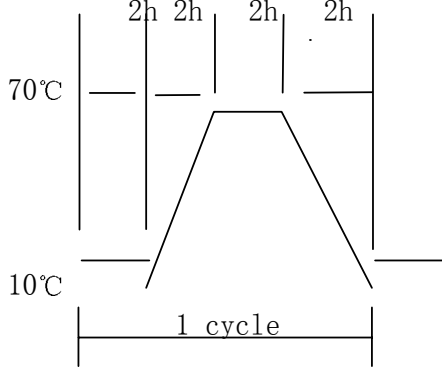
Item	Conditions	Criteria	Remarks
High Temp. (Storage)	Temperature: $85 \pm 2^{\circ}\text{C}$ Duration: 72hrs In unlighted state.	Free of the Major Defects	Measurement shall be done after the specimens are kept at room temperature for 24 hrs.
High Temp. (Operation)	Temperature: $70 \pm 2^{\circ}\text{C}$ Duration: 96hrs In unlighted state.		
Low Temp. (Storage)	Temperature: $-40 \pm 3^{\circ}\text{C}$ Duration: 72hrs In unlighted state.		
Low Temp. (Operation)	Temperature: $-20 \pm 2^{\circ}\text{C}$ Duration: 24hrs		
Temperature Cycling	 <p>Number of Repeating: 5 All Segments are lit.</p>		
Humidity (steady state)	Humidity: 90~95% Temperature: $40 \pm 2^{\circ}\text{C}$ Duration: 96hrs		
Vibration	Frequency: 10~55Hz Displacement: 1.5mm Direction: $\pm X, \pm Y, \pm Z$ Duration: 6hrs (2hrs for each direction) Condition: In unlighted state		

STANDARD NAME		DOCUMENT NO.	REV. NO	PAGE
			00	

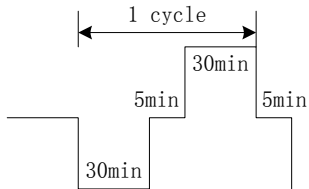
Item	Condition	Criteria	Remarks
Shock	G: 40G Time: 10ms Wave: Half sine wave Direction: $\pm X$ 、 $\pm Y$ 、 $\pm Z$ (3 times in each of the direction) Conditio: In unlighted State	Free of the Major Defects	Measurement shall be done after the specimens are kept at room temperature for 24 hrs.
Thermal Sock	 <p>Number of Repeating: 5 Unlighted state.</p>		

8. DESIGN CHANGE

8.1

8.2