

User's Guide

M0116MY-161LSBR2-1

VFD- RoHS Compliant

(Vacuum Fluorescent Display Module)

For product support, contact

Newhaven Display International
2511 Technology Drive, #101
Elgin, IL 60124

Tel: (847) 844-8795 Fax: (847) 844-8796

February 28, 2008

| | | | | |
|------------------|----------------------------|--------------|---------|------|
| STANDARD NAME | SPECIFICATION FOR APPROVAL | DOCUMENT NO. | REV. NO | PAGE |
| | | | 1.0 | 1/10 |

1. SCOPE

This specification applies to VFD module (Model No: M0116MY-161LSB2-1) .

2. FEATURES

- 2.1 Simple connection to the host system data bus via four-wire clocked serial interface.
- 2.2 Since a DC/DC converter is used, only +5Vdc power source is required to operate the module.
- 2.3 One chip controller offers integral 64×16 bit programmable logic array, low power consumption and high reliability in services.
- 2.4 32 brightness levels can be selected by brightness control command.
- 2.5 High quality vacuum fluorescent display provides an attractive and readable medium.
Other colors can be achieved by simple wavelength filters.
- 2.6 Characters are provided in an attractive 14-segment starburst format.

3. GENERAL DESCRIPTIONS

- 3.1 This specification becomes effective after being approved by the purchaser.
- 3.2 When any conflict is found in the specification, appropriate action shall be taken upon agreement of both parties.
- 3.3 The expected necessary service parts should be arranged by the customer before the completion of production.

4. PRODUCT SPECIFICATIONS

- 4.1 Type Table-1

| | |
|--------------|-------------------------------|
| Type | M0116MY-162LSB1-1 |
| Digit Format | 14Seg. & Comma, Decimal point |

- 4.2 Outer Dimensions, Weight (See Fig-4 on Page 4/11 for details) Table-2

| Parameter | | Specification | Unit |
|---------------------|-----------|-----------------|------|
| Outer Dimensions | Width | 177.3 ± 0.5 | mm |
| | Height | 32.0 ± 0.5 | mm |
| | Thickness | 15.0 Max | mm |
| Weight | | Typical 90 | G |

| | | | | |
|------------------|----------------------------|--------------|---------|------|
| STANDARD NAME | SPECIFICATION FOR APPROVAL | DOCUMENT NO. | REV. NO | PAGE |
| | | | 1.0 | 2/10 |

4.3 Specification of Display Panel (See Fig-4 on Page 5/10)

Table-3

| Parameter | Symbol | Specification | Unit |
|----------------------|--------|-------------------------|------|
| Display Size (W*H) | - | 132.5*11.0 | mm |
| Number of Digit | - | 16 Digits | - |
| Character Size (W*H) | - | 5.0*10.0 | mm |
| Display Color | - | Blue-Green (peak 505nm) | mm |

4.4 Environment Conditions

Table-4

| Parameter | Symbol | Min | Max | Unit |
|--------------------------|--------|-----|-----|------|
| Operating Temperature | Topr | -45 | +85 | °C |
| Storage Temperature | Tstg | -50 | +95 | °C |
| Humidity (Operating) | Hopr | 0 | 85 | % |
| Humidity (Non-operating) | Hstg | 0 | 90 | % |
| Vibration (10~55Hz) | - | - | 4 | G |
| Shock | - | - | 40 | G |

4.5 Absolute Maximum Ratings

Table-5

| Parameter | Symbol | Min | Max. | Unit |
|----------------------|--------|------|------|------|
| Supply Voltage | Vcc | - | 6.0 | Vdc |
| Input Signal Voltage | Vis | -0.4 | 5.5 | Vdc |

4.6 Recommend Operating Conditions

Table-6

| Parameter | Symbol | Min | Typ. | Max. | Unit |
|-----------------------|--------|-----|------|------|------|
| Supply Voltage | Vcc | 4.5 | 5.0 | 5.5 | Vdc |
| H-Level Input Voltage | Vih | 2.0 | - | - | Vdc |
| L-Level Input Voltage | Vil | - | - | 0.8 | Vdc |

4.7 DC Characteristics (Ta=+25°C, Vcc=+5.0Vdc)

Table-7

| Parameter | Symbol | Min. | Typ. | Max. | Unit |
|-----------------------|--------|------|------|-------|-------|
| Supply current ※) | Icc | - | 350 | 500 | mA |
| H-Level Input Current | Iih | - | - | 20.0 | μA |
| L-Level Input Current | Iil | - | - | -0.36 | μA |
| Luminance | L | 100 | 200 | - | ft -L |

※) The surge current can be approx. 3 times the specified supply current at power on..

| | | | | |
|---------------|----------------------------|--------------|--------|------|
| STANDARD NAME | SPECIFICATION FOR APPROVAL | DOCUMENT NO. | REV NO | PAGE |
| | | | 1.0 | 3/10 |

4.8 Timing Chart

4.8.1 SCLK and DATA Timing

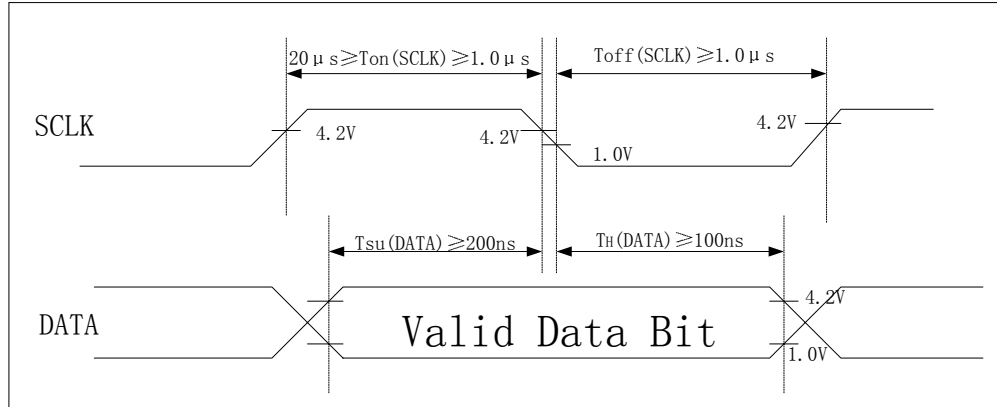

Fig-1. SCLK and Serial DATA Timing Diagram

4.8.2 Data word LSB/MSB Timing

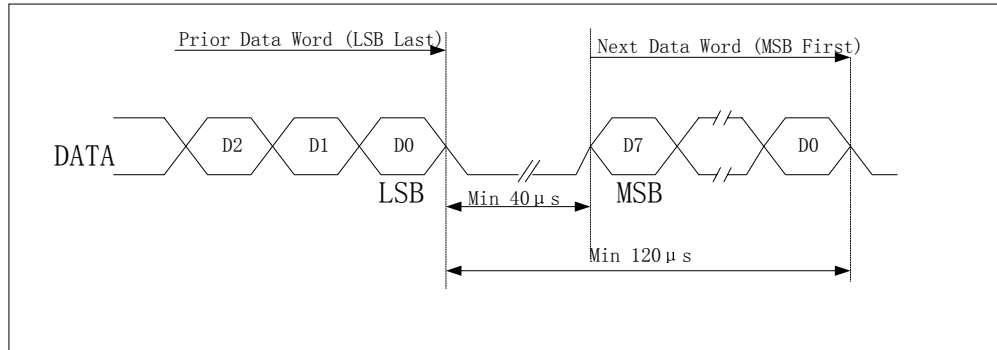

Fig-2 Data Word LSB/MSB Timing Diagram

4.9 Signal Interfacing

Table-8

| Pin # | Signal | Signal Description |
|------------|--------|--|
| 1 | Vcc | Vcc: Power Supply Terminal (+5Vdc is required) |
| 3 | SCLK | SCLK: Serial Clock of Shift Register (Falling Edge Active) |
| 5 | DATA | DATA: Serial Input Data |
| 7 | /RST | RST: Reset Signal Input (Active Low) |
| 9 | N/C | N/C: No Connection/ |
| 2,4,6,8,10 | GND | GND: Power/Signal Ground Terminal |

| STANDARD NAME | SPECIFICATION FOR APPROVAL | DOCUMENT NO. | REV. NO | PAGE |
|---------------|----------------------------|--------------|---------|------|
| | | | | 1.0 |

4.10 System Block Diagram

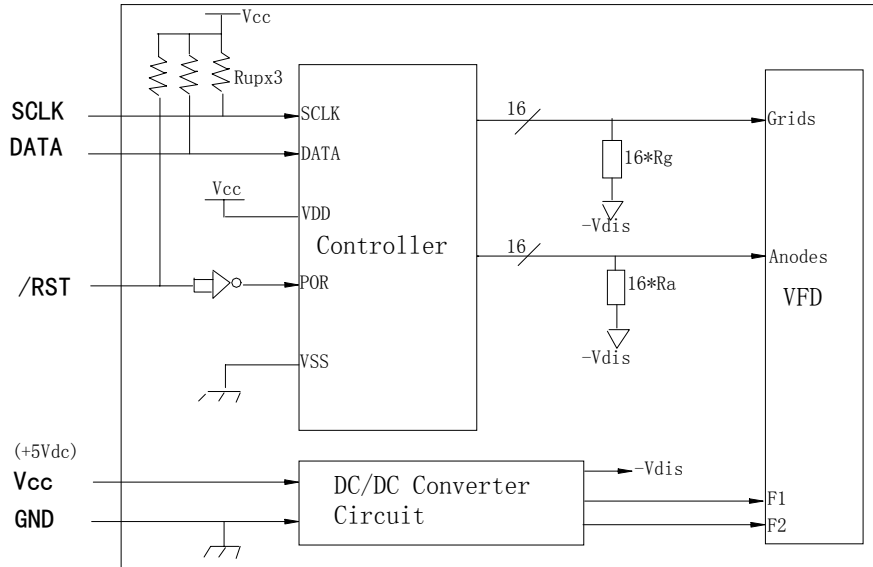

Fig-3 VFD Module System Block Diagram

4.11 Outer Dimensions

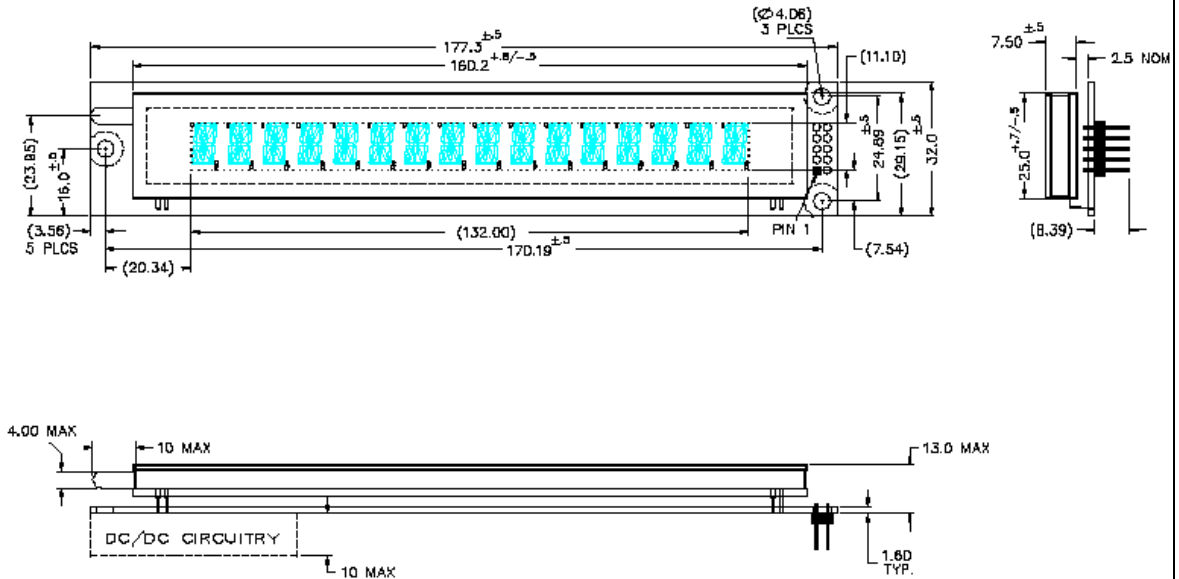

Fig-4. Outer Dimensions

| | | | | |
|------------------|----------------------------|--------------|---------|------|
| STANDARD NAME | SPECIFICATION FOR APPROVAL | DOCUMENT NO. | REV. NO | PAGE |
| | | | 1.0 | 5/10 |

5. FUNCTIONS

The module has control data, display data write and reset functions.

Input data from the host system is loaded into the module's display buffer via the serial data input channel as 8-bit serial data. The MSB value of 8-bit serial data determines whether the input data into this module is control data or display data.

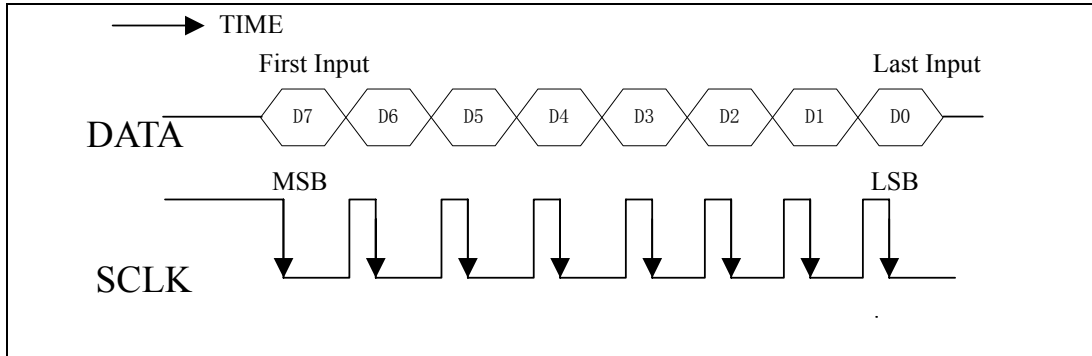

Fig-5 Synchronous Serial Data Input

5.1 Control Data

The control data can be input by setting MSB to "1" : In addition, a command type and associated data with the command is determined by the D6~D0.

| Command | Function | Binary Code | | | | | | | |
|------------------------|----------------------------|-------------|----|----|-------|-------|-------|-------|-------|
| | | D7 | D6 | D5 | D4 | D3 | D2 | D1 | D0 |
| Buffer Pointer Control | Specifies the RAM address. | 1 | 0 | 1 | 0 | 2^3 | 2^2 | 2^1 | 2^0 |
| Digit Counter Control | Sets the number of digits. | 1 | 1 | 0 | 0 | 2^3 | 2^2 | 2^1 | 2^0 |
| Brightness Control | Sets the brightness. | 1 | 1 | 1 | 2^4 | 2^3 | 2^2 | 2^1 | 2^0 |

| | | | | |
|------------------|----------------------------|--------------|--------|------|
| STANDARD NAME | SPECIFICATION FOR APPROVAL | DOCUMENT NO. | REV.NO | PAGE |
| | | | 1.0 | 6/10 |

5.1.1 Buffer Pointer Control

This command changes the display contents only at an arbitrary digit.

(The RAM write address is set.) The digit position to be modified is represented by the value of D3~D0. If the most significant digit(left-end digit) is to be selected, each of D3~D0 are set to a value of "1" and if the second digit is to be selected, each of D3~D3 set to a value of "0". Otherwise a decimal value of from "1" to "12" should be entered. The set value of D3~D0 is lower than the decimal value of the specified position by 2.

Table-10

| Digit | Binary Code | | | | | | | | Digit | Binary Code | | | | | | | |
|----------|-------------|-----|-----|-----|-----|-----|-----|-----|-----------|-------------|-----|-----|-----|-----|-----|-----|-----|
| | D 7 | D 6 | D 5 | D 4 | D 3 | D 2 | D 1 | D 0 | | D 7 | D 6 | D 5 | D 4 | D 3 | D 2 | D 1 | D 0 |
| Left End | 1 | 0 | 1 | 0 | 1 | 1 | 1 | 1 | 9th | 1 | 0 | 1 | 0 | 0 | 1 | 1 | 1 |
| 2nd | 1 | 0 | 1 | 0 | 0 | 0 | 0 | 0 | 10th | 1 | 0 | 1 | 0 | 1 | 0 | 0 | 0 |
| 3rd | 1 | 0 | 1 | 0 | 0 | 0 | 0 | 1 | 11th | 1 | 0 | 1 | 0 | 1 | 0 | 0 | 1 |
| 4th | 1 | 0 | 1 | 0 | 0 | 0 | 1 | 0 | 12th | 1 | 0 | 1 | 0 | 1 | 0 | 1 | 0 |
| 5th | 1 | 0 | 1 | 0 | 0 | 0 | 1 | 1 | 13th | 1 | 0 | 1 | 0 | 1 | 0 | 1 | 1 |
| 6th | 1 | 0 | 1 | 0 | 0 | 1 | 0 | 0 | 14th | 1 | 0 | 1 | 0 | 1 | 1 | 0 | 0 |
| 7th | 1 | 0 | 1 | 0 | 0 | 1 | 0 | 1 | 15th | 1 | 0 | 1 | 0 | 1 | 1 | 0 | 1 |
| 8th | 1 | 0 | 1 | 0 | 0 | 1 | 1 | 0 | Right End | 1 | 0 | 1 | 0 | 1 | 1 | 1 | 0 |

5.1.2 Digit Counter Control

This command is used to define the number of display digits. The code is normally used only during initialization routine of the host system.

If all 13 characters are to be controlled, each of D3~D0 are set to a value of "0", otherwise a decimal value from "1" to "12" is entered, corresponding to the actual number of characters to be controlled.

Table-11

| Number of Display Digit | Binary Code | | | | | | | | Number of Display Digit | Binary Code | | | | | | | |
|-------------------------------|-------------|-----|-----|-----|-----|-----|-----|-----|-------------------------------|-------------|-----|-----|-----|-----|-----|-----|-----|
| | D 7 | D 6 | D 5 | D 4 | D 3 | D 2 | D 1 | D 0 | | D 7 | D 6 | D 5 | D 4 | D 3 | D 2 | D 1 | D 0 |
| 1 | 1 | 1 | 0 | 0 | 0 | 0 | 0 | 1 | 9 | 1 | 1 | 0 | 0 | 1 | 0 | 0 | 1 |
| 2 | 1 | 1 | 0 | 0 | 0 | 0 | 1 | 0 | 10 | 1 | 1 | 0 | 0 | 1 | 0 | 1 | 0 |
| 3 | 1 | 1 | 0 | 0 | 0 | 0 | 1 | 1 | 11 | 1 | 1 | 0 | 0 | 1 | 0 | 1 | 1 |
| 4 | 1 | 1 | 0 | 0 | 0 | 1 | 0 | 0 | 12 | 1 | 1 | 0 | 0 | 1 | 1 | 0 | 0 |
| 5 | 1 | 1 | 0 | 0 | 0 | 1 | 0 | 1 | 13 | 1 | 1 | 0 | 0 | 1 | 1 | 0 | 1 |
| 6 | 1 | 1 | 0 | 0 | 0 | 1 | 1 | 0 | 14 | 1 | 1 | 0 | 0 | 1 | 1 | 1 | 0 |
| 7 | 1 | 1 | 0 | 0 | 0 | 1 | 1 | 1 | 15 | 1 | 1 | 0 | 0 | 1 | 1 | 1 | 1 |
| 8 | 1 | 1 | 0 | 0 | 1 | 0 | 0 | 0 | 16 | 1 | 1 | 0 | 0 | 0 | 0 | 0 | 0 |

| | | | | |
|------------------|----------------------------|--------------|--------|------|
| STANDARD NAME | SPECIFICATION FOR APPROVAL | DOCUMENT NO. | REV.NO | PAGE |
| | | | 1.0 | 7/10 |

5.1.3 Brightness Control

This command sets the brightness of the VFD. This command allows the brightness to be adjusted by 1/32 step. As shown in Table-12, the test value ranges from 0 to 31.

Table-12

| Brightness Level | Binary Code | | | | | | | | Brightness Level | Binary Code | | | | | | | |
|---------------------|-------------|--------|--------|--------|--------|--------|--------|--------|---------------------|-------------|--------|--------|--------|--------|--------|--------|--------|
| | D 7 | D 6 | D 5 | D 4 | D 3 | D 2 | D 1 | D 0 | | D 7 | D 6 | D 5 | D 4 | D 3 | D 2 | D 1 | D 0 |
| 0/31(0.0%) | 1 | 1 | 1 | 0 | 0 | 0 | 0 | 0 | 16/31(51.6%) | 1 | 1 | 1 | 1 | 0 | 0 | 0 | 0 |
| 1/31(3.2%) | 1 | 1 | 1 | 0 | 0 | 0 | 0 | 1 | 17/31(54.8%) | 1 | 1 | 1 | 1 | 0 | 0 | 0 | 1 |
| 2/31(6.4%) | 1 | 1 | 1 | 0 | 0 | 0 | 1 | 0 | 18/31(58.1%) | 1 | 1 | 1 | 1 | 0 | 0 | 1 | 0 |
| 3/31(9.7%) | 1 | 1 | 1 | 0 | 0 | 0 | 1 | 1 | 19/31(61.2%) | 1 | 1 | 1 | 1 | 0 | 0 | 1 | 1 |
| 4/31(12.9%) | 1 | 1 | 1 | 0 | 0 | 1 | 0 | 0 | 20/31(64.5%) | 1 | 1 | 1 | 1 | 0 | 1 | 0 | 0 |
| 5/31(16.1%) | 1 | 1 | 1 | 0 | 0 | 1 | 0 | 1 | 21/31(67.7%) | 1 | 1 | 1 | 1 | 0 | 1 | 0 | 1 |
| 6/31(19.4%) | 1 | 1 | 1 | 0 | 0 | 1 | 1 | 0 | 22/31(71.0%) | 1 | 1 | 1 | 1 | 0 | 1 | 1 | 0 |
| 7/31(22.6%) | 1 | 1 | 1 | 0 | 0 | 1 | 1 | 1 | 23/31(74.2%) | 1 | 1 | 1 | 1 | 0 | 1 | 1 | 1 |
| 8/31(25.8%) | 1 | 1 | 1 | 0 | 1 | 0 | 0 | 0 | 24/31(77.4%) | 1 | 1 | 1 | 1 | 1 | 0 | 0 | 0 |
| 9/31(29.0%) | 1 | 1 | 1 | 0 | 1 | 0 | 0 | 1 | 25/31(80.6%) | 1 | 1 | 1 | 1 | 1 | 0 | 0 | 1 |
| 10/31(32.3%) | 1 | 1 | 1 | 0 | 1 | 0 | 1 | 0 | 26/31(83.9%) | 1 | 1 | 1 | 1 | 1 | 0 | 1 | 0 |
| 11/31(35.5%) | 1 | 1 | 1 | 0 | 1 | 0 | 1 | 1 | 27/31(87.1%) | 1 | 1 | 1 | 1 | 1 | 0 | 1 | 1 |
| 12/31(38.7%) | 1 | 1 | 1 | 0 | 1 | 1 | 0 | 0 | 28/31(90.3%) | 1 | 1 | 1 | 1 | 1 | 1 | 0 | 0 |
| 13/31(41.9%) | 1 | 1 | 1 | 0 | 1 | 1 | 0 | 1 | 29/31(93.5%) | 1 | 1 | 1 | 1 | 1 | 1 | 0 | 1 |
| 14/31(45.2%) | 1 | 1 | 1 | 0 | 1 | 1 | 1 | 0 | 30/31(96.8%) | 1 | 1 | 1 | 1 | 1 | 1 | 1 | 0 |
| 15/31(48.4%) | 1 | 1 | 1 | 0 | 1 | 1 | 1 | 1 | 31/31(100%) | 1 | 1 | 1 | 1 | 1 | 1 | 1 | 1 |

5.2 Input Display Data Word

Display data words are loaded into the display buffer of module as 8-bit codes, with the MSB set to "0". The 64 available codes are shown in Table-13 on next page.

16 display data words must be entered to fully load the display data buffer. The display buffer pointer (write in position) specified by the buffer. Pointer control command is automatically incremented by one each time the display data is entered.

To set the comma or decimal point, the display data codes of 2C Hex or 2E Hex is entered respectively. Only when 2C Hex and 2E Hex data are entered, the display buffer pointer in the RAM is not automatically incremented but stays present location.

| | | | | |
|------------------|----------------------------|--------------|--------|------|
| STANDARD NAME | SPECIFICATION FOR APPROVAL | DOCUMENT NO. | REV.NO | PAGE |
| | | | 1.0 | 8/10 |

Character Font Table

Table-14

| | | | | | | | | | | | | | | | |
|----|--|----|--|----|--|----|--|----|--|----|--|----|--|----|--|
| 00 | | 08 | | 10 | | 18 | | 20 | | 28 | | 30 | | 38 | |
| 01 | | 09 | | 11 | | 19 | | 21 | | 29 | | 31 | | 39 | |
| 02 | | 0A | | 12 | | 1A | | 22 | | 2A | | 32 | | 3A | |
| 03 | | 0B | | 13 | | 1B | | 23 | | 2B | | 33 | | 3B | |
| 04 | | 0C | | 14 | | 1C | | 24 | | 2C | | 34 | | 3C | |
| 05 | | 0D | | 15 | | 1D | | 25 | | 2D | | 35 | | 3D | |
| 06 | | 0E | | 16 | | 1E | | 26 | | 2E | | 36 | | 3E | |
| 07 | | 0F | | 17 | | 1F | | 27 | | 2F | | 37 | | 3F | |

14-Segment Display

| | | | | |
|------------------|-----------------------------------|--------------|---------|------|
| STANDARD NAME | SPECIFICATION FOR APPROVAL | DOCUMENT NO. | REV. NO | PAGE |
| | | | 1.0 | 9/10 |

5.3 RESET

The reset function allows the users to re-initialize the alphanumeric display controller, while the power is still applied to the module, by applying a logical “0” to pin #5 and pin #7(/RST) of the connector. (Pulse Width \geq 200us)

When the controller is initialized, the display status is shown in Table-13. The RAM data (Display Buffer Data) are the same as the prior data.

Table-13

| Parameter | Reset Status | Binary Code | | | | | | | |
|-------------------------|----------------|-------------|----|----|----|----|----|----|----|
| | | D7 | D6 | D5 | D4 | D3 | D2 | D1 | D0 |
| Write in Position | Left End Digit | 1 | 0 | 1 | 0 | 1 | 1 | 1 | 1 |
| Number of Display Digit | 16 Digits | 1 | 1 | 0 | 0 | 0 | 0 | 0 | 0 |
| Brightness Level | 0% | 1 | 1 | 1 | 0 | 0 | 0 | 0 | 0 |

| | | | | |
|----------------|-----------------------------------|--------------|--------|-------|
| TNDARD NAME | SPECIFICATION FOR APPROVAL | DOCUMENT NO. | REV.NO | PAGE |
| | | | 1.0 | 10/10 |

6. OPERATING RECOMMENDATIONS

- 6.1 Avoid applying excessive shock or vibration beyond the specification for the VFD module.
- 6.2 Since VFD is made of glass material, careful handling is required.
- 6.3 When mounting the VFD module to your system, leave a slight gap between the VFD glass and your front panel.
The module should be mounted without stress to avoid flexing of the PCB.
- 6.4 Avoid plugging or unplugging the interface connection with the power on, otherwise it may cause severe damage to input circuitry.
- 6.5 Slow starting power supply may cause non-operation because one chip Mi-com won't be reset.
- 6.6 Exceeding any of maximum ratings may cause the permanent damage.
- 6.7 Since the VFD module contain high voltage source, careful handling is required while power is on.
- 6.8 When the power is turned off, the capacitor does not discharge immediately.
So the high voltage applied to the VFD must not get in contact with ICs.
In other words, short-circuit of mounted components on PCB within 30 seconds after power-off may cause damage to the module.
- 6.9 The power supply must be capable of providing at least 3 times the rated current, because the surge current may be 3 times the specified current consumption when the power is turned on.
- 6.10 Avoid using the module where excessive noise interference is expected.
Noise may affect the interface signal and cause improper operation. It is important to keep the length of the interface cable less than 50cm.
- 6.11 Since all VFD modules contain C-MOS ICs, anti-static handling procedures are always required.