

# Vacuum Fluorescent Display Module Hardware Specification

Model: GU256X64C-3xx0 series

Specification No: DS-904-0001-00

Date Of Issue: September 03, 2003 (00)

Revision:

Published by  
NORITAKE ITRON Corp. / Japan  
<http://www.noritake-itron.jp/>

This specification is subject to change without prior notice.

Index.

1	General Description .....	2
1.1	Scope .....	2
1.2	Construction .....	2
1.3	Outline .....	2
1.4	Block Diagram .....	2
2	General Purpose I/O port .....	3
3	Electrical specification .....	3
3.1	Absolute Maximum Ratings .....	3
3.2	Electrical ratings .....	4
3.3	Electrical Characteristics .....	4
4	Optical Specifications .....	5
5	Environmental Specifications .....	5
6	Interface .....	6
6.1	Type of interface .....	6
6.2	Interface timing .....	6
6.2.1	RS-232 Asynchronous serial interface timing .....	6
6.2.2	Parallel interface timing .....	7
7	Setup .....	7
7.1	DIP-Switch (SW1) .....	7
8	Connector .....	8
8.1	RS-232 Interface & Power connector (CN3) .....	8
8.2	Parallel interface & Power connector (CN2) .....	8
8.3	I/O Port connector (CN1, 14 through holes) .....	8
8.4	Connectors .....	8
9	Outline Drawing .....	9
	Notice for the Cautious Handling VFD Modules .....	10

# 1 General Description

## 1.1 Scope

This specification covers the hardware and its requirements of the vacuum fluorescent graphic display module GU256X64C-3xx0 series.

## 1.2 Construction

The module consists of a 256 x 64dot graphic BD-VFD, refresh RAM, character generator, DC/DC converter, display controller, and all necessary control logic. The module can simultaneously display graphic patterns and/or characters on the screen.

## 1.3 Outline

Power supply: + 5 V<sub>DC</sub> only  
 Interface: Parallel interface, RS-232 Asynchronous Serial interface  
 I/O port: 12bits General purpose I/O port available  
           8bit Input/Output port (Port 0), 4bit Input port (Port 1)  
 Protocol: Direct mode  
           Packet mode  
 Function: Character display  
           Graphic display  
           Control command  
           Display action command  
           Draw command  
           Window function  
           General Purpose I/O port control  
           Macro, Program Macro function  
           Character and Bit Image download function  
           Memory SW

For more detail;

Refer to specification:

DS-957-0005-xx: for 256x64dot –31xx series “General function” software spec

DS-957-0003-xx: for 256x64dot –39xx series “General function” software spec

DS-954-0003-xx: “Program Macro” software spec

## 1.4 Block Diagram

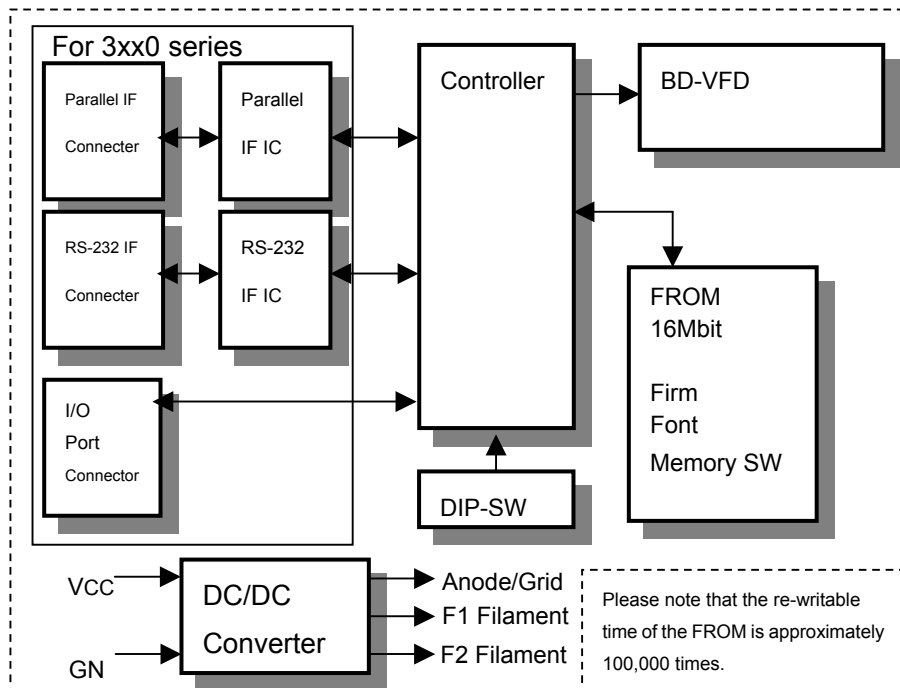

## 2 General Purpose I/O port

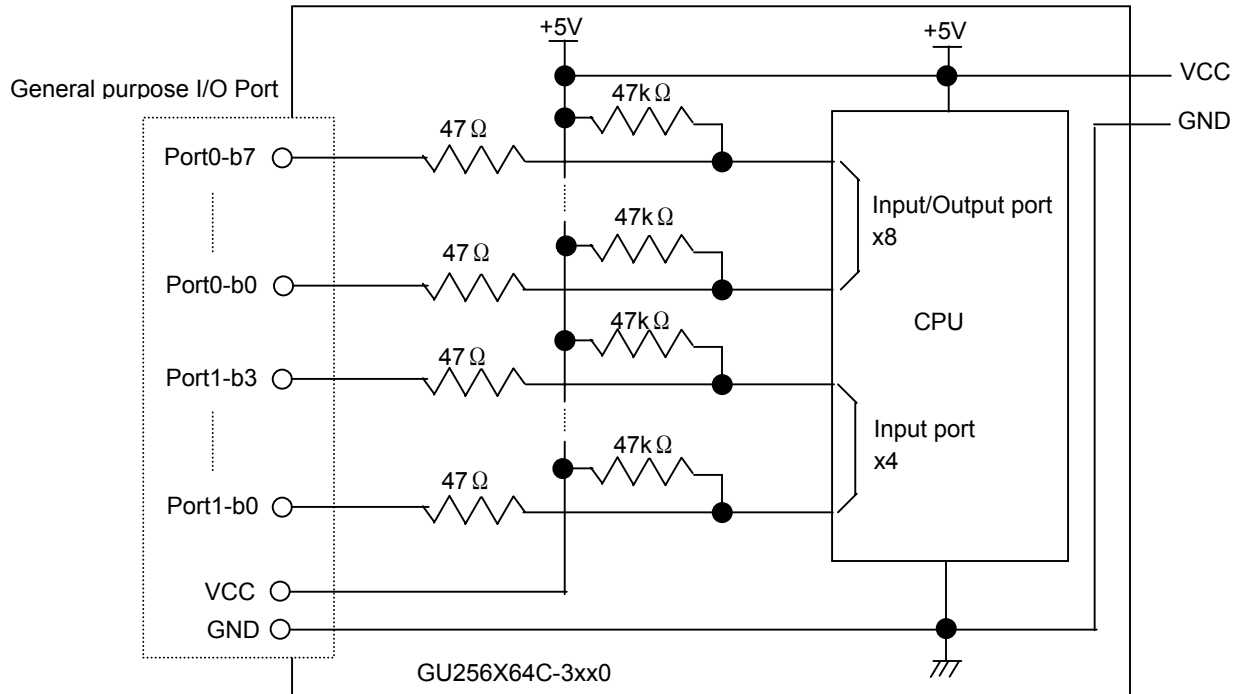

Refer to 3.3 Electrical Characteristics “General purpose I/O port supply Voltage for –3xx0, –3xx1 series.”  
 For controlling, refer to 256x64dot “General function” software spec., “I/O Port Input/Output setting”, “I/O Port Output”, “I/O Port Input”.

## 3 Electrical specification

### 3.1 Absolute Maximum Ratings

#### Power Supply Voltage

Parameter	Symbol	Min.	Typ.	Max.	Unit	Note
Power Supply Voltage	VCC	-0.3	-	+6.0	VDC	

#### Logic Supply Voltage

Parameter	Symbol	Min.	Typ.	Max.	Unit	Note
Parallel I/F D0 –D7 /WR	VpIN	-0.3	-	Vcc+0.3	VDC	
RS-232 Serial I/F RXD, DSR	VsIN	-25		+25	VDC	

#### I/O port supply Voltage

Parameter	Symbol	Min.	Typ.	Max.	Unit	Note
I/O port Port 0, Port 1	ViIN	-0.3	-	Vcc+0.3	VDC	

### 3.2 Electrical ratings

#### Power Supply Voltage

Parameter	Symbol	Min.	Typ.	Max.	Unit	Note
Power Supply Voltage	VCC	4.75	5.0	5.25	VDC	

All driving voltage for the VFD is converted from the DC/DC converter on board.

### 3.3 Electrical Characteristics

#### Logic input/output condition

Measuring Conditions: Ambient temperature = 25degrees, VCC =5.0VDC

Parameter		Symbol	Min.	Typ.	Max.	Unit	Condition	Note
Parallel I/F	Logic input current D0 – D7, /WR	I <sub>pIH</sub>	-	-	1.0	uADC	-	-
		I <sub>pIL</sub>	-	-	-200	uADC	-	-
	Logic input voltage D0 – D7, /WR	V <sub>pIH</sub>	0.8VCC		VCC	VDC	-	-
		V <sub>pIL</sub>	0		0.2VCC	VDC	-	-
	Logic output voltage RDY	V <sub>pOH</sub>	3.5		VCC	VDC	I <sub>OH</sub> =-10uA	(1)
		V <sub>pOL</sub>	0		0.6	VDC	I <sub>OL</sub> =4mA	
RS-232 I/F	Logic input voltage RXD, DSR	V <sub>sIH</sub>	3	-	15	VDC	-	-
		V <sub>sIL</sub>	-15	-	-3	VDC	-	-
	Logic output voltage TXD, DTR	V <sub>sOH</sub>	5	-	-	VDC	R <sub>L</sub> =3KΩ	-
		V <sub>sOL</sub>	-	-	-5	VDC		-
	Logic input Impedance RXD, DSR	R <sub>sIN</sub>	3	-	7	K Ω		-

(1) "RDY" is open collector terminal. (Pull up by 47Kohm)

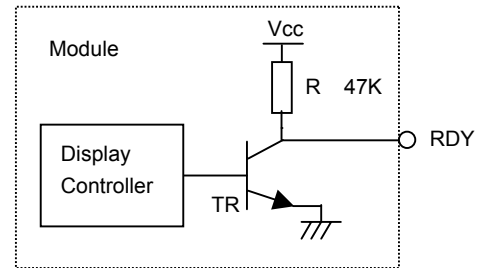

#### General purpose I/O port supply Voltage

Measuring Conditions: Ambient temperature = 25degrees, VCC =5.0VDC

Parameter		Symbol	Min.	Typ.	Max.	Unit	Condition	Note
General purpose I/O port	Logic input current Port 0, 1	I <sub>iIH</sub>	-	-	1.0	uADC	-	-
		I <sub>iIL</sub>	-	-	-200	uADC	-	-
	Logic input voltage Port 0	V <sub>iIH</sub>	2.0	-	VCC	VDC	-	-
		V <sub>iIL</sub>	0	-	0.8	VDC	-	-
	Logic output voltage Port 0	V <sub>iOH</sub>	VCC-0.6	-	-	VDC	I <sub>OH</sub> =-200uA	-
		V <sub>iOL</sub>	-	-	0.5	VDC	I <sub>OL</sub> =1.6mA	
	Logic input voltage Port 1 (Schmidt Trigger input)	V <sub>iT-</sub>	1.0	-	-	VDC	-	-
		V <sub>iT+</sub>	-	-	0.7VCC	VDC	-	-
		V <sub>iT+</sub> - V <sub>iT-</sub>	0.4	-	-	VDC	-	-

**General purpose I/O port output permissible current**

Measuring Conditions: Ambient temperature = 25degrees, VCC =5.0VDC

Parameter		Symbol	Min.	Typ.	Max.	Unit	Condition	Note
General purpose I/O port	Output permissible current Port 0, 1 (per 1 terminal)	liOH	—	—	1.5	mADC	-	-
		liOL	—	—	8	mADC	-	-
	Output permissible current Port 0, 1 (The Sum of all I/O terminal)	liOH	—	—	8	mADC	-	-
		liOL	—	—	30	mADC	-	-

**Output current should not be exceeded from the value of above table.****In case of driving the LED or some other device directly, please be sure to insert current limiter into an output line.****Power Supply condition**

Measuring Conditions: Ambient temperature = 25degrees, VCC =5.0VDC

Parameter	Symbol	Min.	Typ.	Max.	Unit	Condition	Note
Power Supply Current 1	ICC1	-	0.43	0.56	ADC		(2)
Power Supply Current 2	ICC2	-	0.33	0.43	ADC		(3)
Power Supply Current 3	ICC3	-	80	120	mADC		(4)

Note

(2),(3) ICC1 shows the current at all dots in the screen are lighted and ICC2 at all dots off. At power on rush, more than 2times current of above table should be expected. Provide the quick rise type power supply (&lt;100msec.).

(4)ICC3 shows the current at Power OFF Mode (Power save mode).

Refer to 256x64dot "General function" software spec., "Display power ON/OFF" command.

**4 Optical Specifications**

Number of dots:	16,384 (256 x 64)
PCB Size:	133.0 mm x 38.0 mm (X x Y)
Display area:	83.08mm x 20.68 mm(X x Y)
Dot size:	0.2mm x 0.2mm(X x Y)
Dot pitch:	0.325mm x 0.325mm (X x Y)
Luminance:	250cd/m <sup>2</sup> Min. (500cd/m <sup>2</sup> Typ.)
Color of illumination:	Green (Blue Green)

**5 Environmental Specifications**

Operating temperature:	-40 to +85degrees
Storage temperature:	-40 to +85degrees
Storage humidity:	20 to 80 % R.H (Non Condensing)
Vibration:	10-55-10Hz, all amplitude 1mm, 30Min., X-Y-Z (Non operating)
Shock:	392m/s <sup>2</sup> (40G) 9mS X-Y-Z (Non operating)

## 6 Interface

### 6.1 Type of interface

The following interfaces are available on this module;  
Parallel interface, RS-232 Serial interface

### 6.2 Interface timing

#### 6.2.1 RS-232 Asynchronous serial interface timing

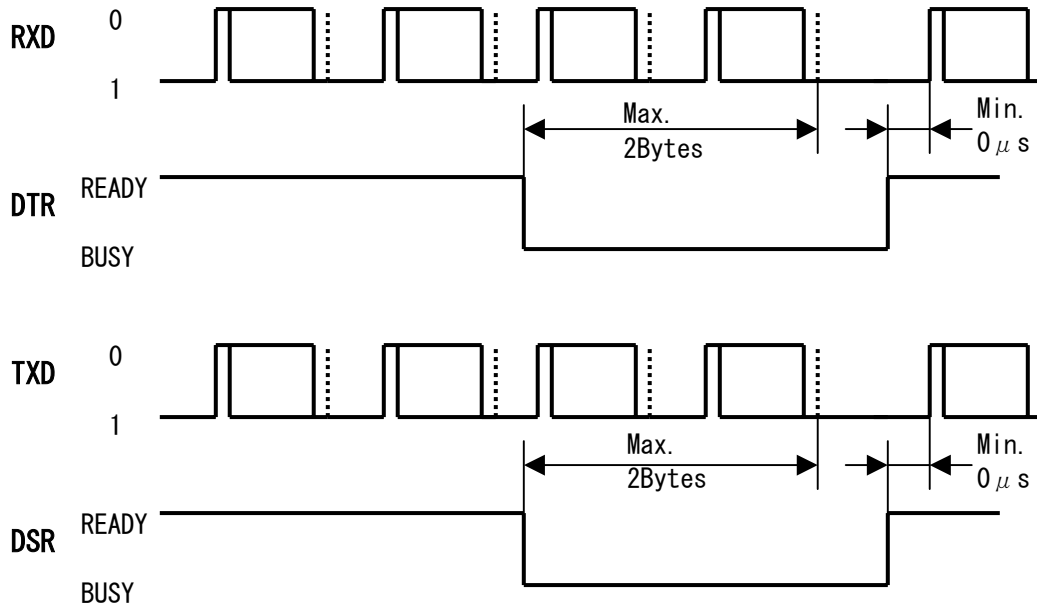

The above timing is RS-232 level. The logical value is inverted from above level.

Interface:

<b>Baud rate</b>	19,200 or 38,400bps (Selectable by DIP SW)
<b>Parity</b>	Non parity
<b>Format</b>	Start (1bit)+Data (8bit)+(Parity)+Stop (1bit)
<b>Handshake</b>	DTR, DSR

Buffer Capacity

<b>Receiving buffer</b>	256byte
<b>Sending buffer</b>	128byte

DTR signal change timing

<b>DTR change</b>	1 (Ready)→0(Busy)	0(Busy) →1(Ready)
<b>Condition</b>	When the rest of receiving buffer or sending buffer size less than 32bytes.	When the rest of receiving buffer and sending buffer size more than 64bytes.

### 6.2.2 Parallel interface timing

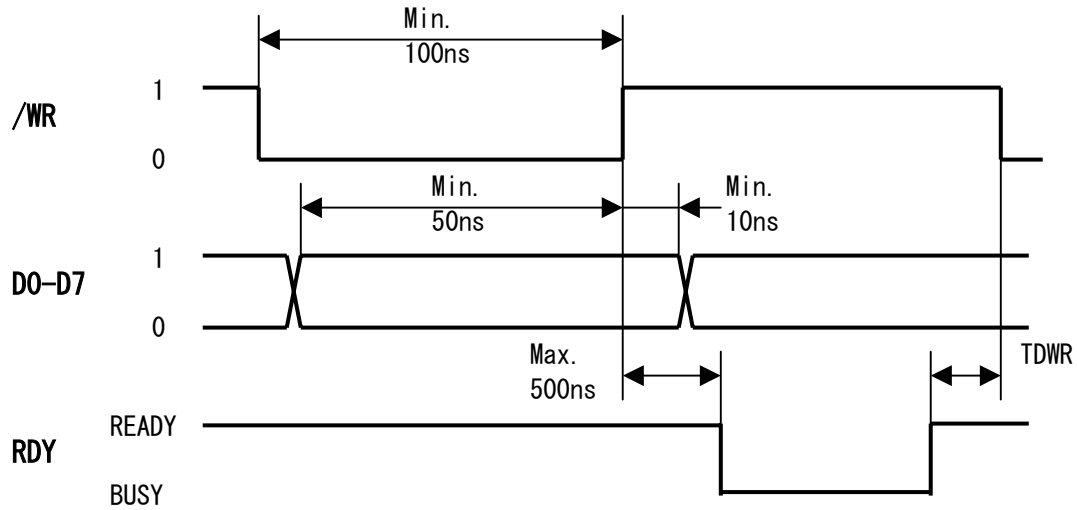

TDWR = Normal command mode: Min 1  $\mu$  S  
 Graphic DMA Mode: Min 15  $\mu$  S

\*RDY=0(BUSY) is output every 1 byte.

This module has 256 bytes of receiving buffer internally, and after data is inputted, RDY signal is set to RDY=0(BUSY) until it is stored into the receiving buffer.

If data is inputted when receiving buffer is full, RDY signal is set to RDY=0(BUSY) until space for 1 byte will be available in receiving buffer.

It changes, and is variable depending on the command contents, or data writing frequency at user side.

Due to above reason, RDY line should be always checked for data writing.

## 7 Setup

### 7.1 DIP-Switch (SW1)

SW No.	Function	Default
1	Display address select (For multi connection)	Off
2		Off
3		Off
4		Off
5	Baud Rate select	Off
6	Command mode select	Off
7	Operating Mode select	Off
8	Protocol select	Off

Detail of setup for DIP SW, refer to 256x64dot "General function" software spec., "Setup"



## 8 Connector

### 8.1 RS-232 Interface & Power connector (CN3)

Pin No.	Signal name	Function	Direction
1	RXD	Data receive	Input
2	DTR	Display busy	Output
3	DSR	Host busy	Input
4	TXD	Data send	Output
5	TEST *	TEST (Factory use only)	Input
6	VCC	Power supply (5V)	Input
7	GND	Ground	Input

\* Internally connected. (Be sure to leave this pin open)

### 8.2 Parallel interface & Power connector (CN2)

Pin No.	Signal name	Function	Direction	Pin No.	Signal name	Function	Direction
1	D7	Data input	Input	2	D6	Data input	Input
3	D5	Data input	Input	4	D4	Data input	Input
5	D3	Data input	Input	6	D2	Data input	Input
7	D1	Data input	Input	8	D0	Data input	Input
9	GND	Ground	Input	10	/WR	Data write	Input
11	GND	Ground	Input	12	RDY	Display READY	Output
13	GND	Ground	Input	14	GND	Ground	Input
15	VCC	Power supply (5V)	Input	16	VCC	Power supply (5V)	Input

### 8.3 I/O Port connector (CN1, 14 through holes)

Pin No.	Signal name	Function	Direction	Pin No.	Signal name	Function	Direction
1	Bit7	Input/Output Port 0	Input/Output	8	Bit0	Port 0	Input/Output
2	Bit6			9	Bit3	Input Port 1	Input
3	Bit5			10	Bit2		
4	Bit4			11	Bit1		
5	Bit3			12	Bit0		
6	Bit2			13	VCC	Power supply (5V)	Input
7	Bit1			14	GND	Ground	Input

### 8.4 Connectors

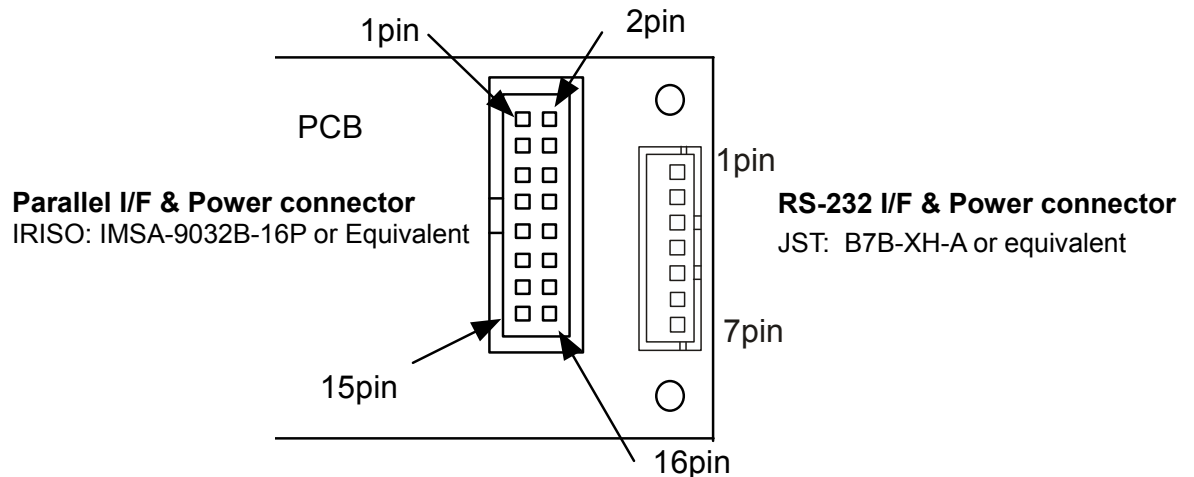

9 Outline Drawing

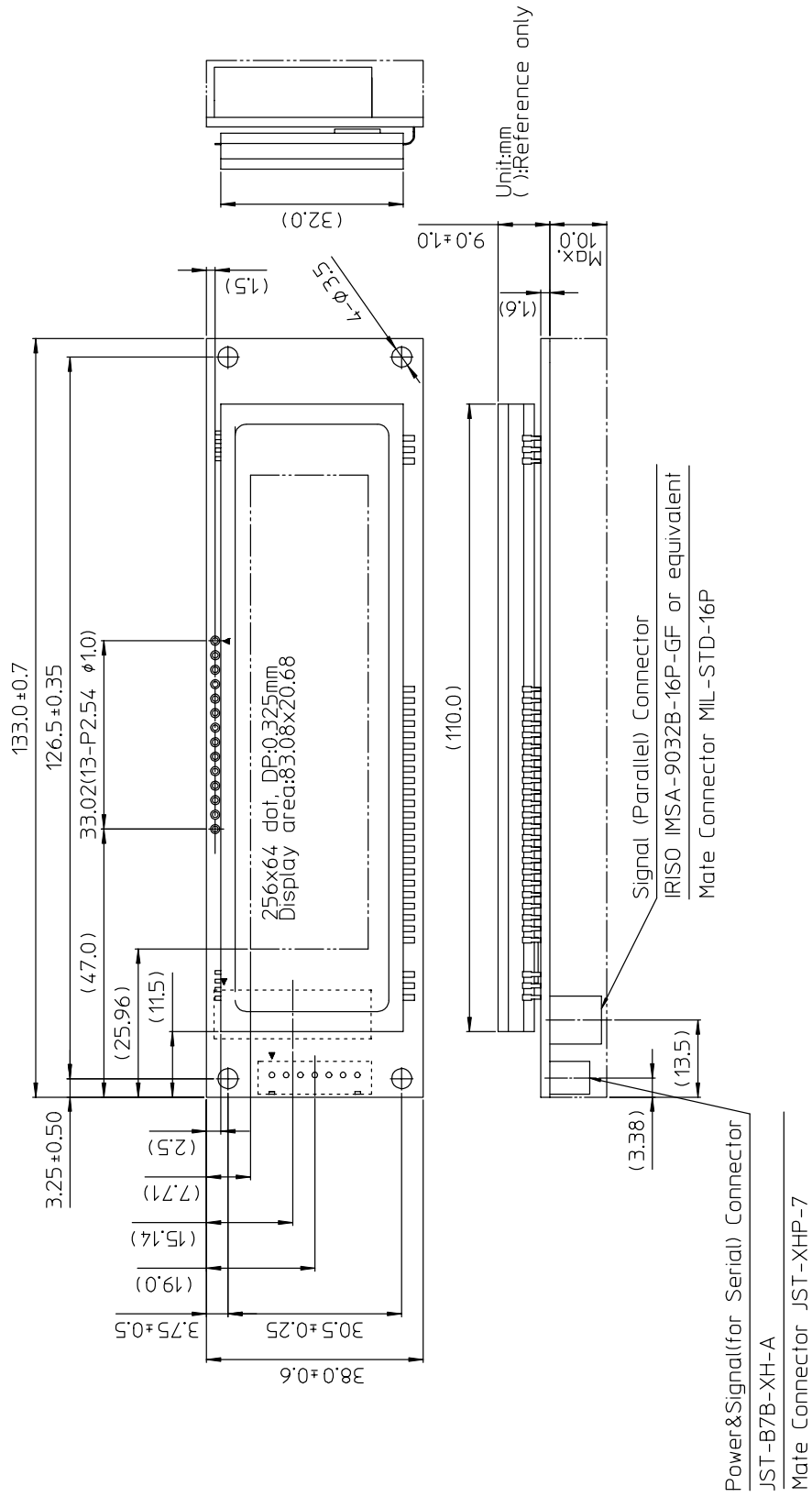

## Notice for the Cautious Handling VFD Modules

### Handling and Usage Precautions:

Please carefully follow the appropriate product application notes for proper usage, safety handling, and operation standards for maximum performance.

#### [VFD tubes are made of glass]

- Because the edges of the VFD glass-envelop are not smooth, it is necessary to handle carefully to avoid injuries to your hands
- Please avoid breaking the VFD glass-envelop to prevent injury from sharp glass particles.
- The tip of the exhaust pipe is fragile so avoid shock from impact.
- It is recommended to allow sufficient open space surrounding the exhaust pipe to avoid possible damage.
- Please design the PCB for the VFD-module within 0.3 mm warping tolerance to avoid any forces that may damage the display due to PCB distortion causing a breakdown of the electrical circuit leading to VFD failure.

#### [High voltage]

- Avoid touching conductive electrical parts, because the VFD-module uses high voltage exceeding 30~100 volts.
- Even when electric power is turned off, it may take more than one minute for the electrical current to discharge.

#### [Cable connection]

- Do not unplug the power and/or data cables of VFD-modules during operating condition because unrecoverable damage may result.
- Sending input signals to the VFD-module during a power off condition sometimes causes I/O port damage.
- It is recommended to use a 30 cm or shorter signal cable to prevent functional failures.

#### [Electrostatic charge]

- VFD-modules need electrostatic free packaging and protection from electrostatic charges during handling and usage.

#### [Structure]

- During operation, VFD and VFD-modules generate heat. Please consider sufficient heat radiation dissipation using heat sink solutions.
- We prefer to use UL grade materials or components in conjunction with VFD-modules.
- Wrap and twist motion causes stress and may break VFDs & VFD modules. Please adhere to allowances within 0.3mm at the point of attachment.

#### [Power]

- Apply regulated power to the VFD-module within specified voltages to protect from failures.
- Because some VFD-modules may consume in rush current equal to twice the typical current at power-on timing, we recommend using a sufficient power capability and quick starting of the power regulator.
- VFD-module needs a specified voltage at the point of connection. Please use an adequate power cable to avoid a decrease in voltage. We also recommend inserting a power fuse for extra protection.

#### [Operating consideration]

- Illuminating phosphor will decrease in brightness during extended operation. If a fixed pattern illuminates for an extended period,( several hours), the phosphor efficiency will decrease compared to the non operating phosphor causing a non uniform brightness among pixels. Please consider programming the display patterns to use all phosphor segments evenly. Scrolling may be a consideration for a period of time to refresh the phosphor condition and improve even illumination to the pixels.
- We recommend using a signal cable 30cm or less to avoid some possible disturbances to the signal.

#### [Storage and operating environment]

- Please use VFD-modules under the recommended specified environmental conditions. Salty, sulfur and dusty environments may damage the VFD-module even during storage.

#### [Discard]

- Some VFDs contain a small amount of cadmium in the phosphor and lead in the solder. When discarding VFDs or VFD-modules, please adhere to governmental related laws or regulations.

#### [Others]

- Although the VFD-module is designed to be protected from electrical noise, please plan your circuitry to exclude as much noise as possible.
- Do not reconstruct or repair the VFD-module without our authorization. We cannot assure the quality or reliability of unauthorized reconstructed VFD-modules.

#### Notice:

- We do not authorize the use of any patents that may be inherent in these specifications.
- Neither whole nor partial copying of these specifications are permitted without our approval.  
If necessary , please ask for assistance from our sales consultant.
- This product is not designed for military, aerospace, medical or other life-critical applications. If you choose to use this product for these applications, please ask us for prior consultation or we cannot take responsibility for problems that may occur.