

Lead (Pb) Free Product - RoHS Compliant

0.150" 4-Character 5 x 7 Dot Matrix Serial Input Alphanumeric Display

Red	HDSP2000LP
Yellow	HDSP2001LP
High Efficiency Red	HDSP2002LP
Green	HDSP2003LP

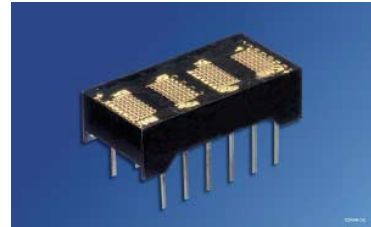

DESCRIPTION

The HDSP200XLP are four digit 5 x 7 dot matrix serial input alphanumeric displays. The displays are available in red, yellow, high efficiency red, or bright green. The package is a standard twelve-pin DIP with a flat plastic lens. The display can be stacked horizontally or vertically to form messages of any length.

The HDSP200XLP has two fourteen-bit CMOS shift registers with built-in row drivers. These shift registers drive twenty-eight rows and enable the design of customized fonts. Cascading multiple displays is possible because of the Data In and Data Out pins. Data In and Out are easily input with the clock signal and displayed in parallel on the row drivers. Data Out represents the output of the 7th bit of digit number four shift register. The shift register is level triggered. The like columns of each character in a display cluster are tied to a single pin (see Block Diagram). High true data in the shift register enables the output current mirror driver stage associated with each row of LEDs in the 5 x 7 diode array.

The TTL compatible V_B input may either be tied to V_{CC} for maximum display intensity or pulse width modulated to achieve intensity control and reduce power consumption.

In the normal mode of operation, input data for digit four, column one is loaded into the seven on-board shift register locations one through seven. Column one data for digits 3, 2, and 1 is shifted into the display shift register locations. Then column one input is enabled for an appropriate period of time, T . A similar process is repeated for columns 2, 3, 4, and 5. If the decode time and load data time into the shift register is t , then with five columns, each column of the display is operating at a duty factor of:

$$DF = \frac{T}{5(T + t)}$$

$T+t$, allotted to each display column, is generally chosen to provide the maximum duty factor consistent with the minimum refresh rate necessary to achieve a flicker free display. For most strobed display systems, each column of the display should be refreshed (turned on) at a minimum rate of 100 times per second.

With columns to be addressed, this refresh rate then gives a value for the time $T+t$ of: $1/[5 \times (100)] = 2.0$ msec. If the device is operated at 5.0 MHz clock rate maximum, it is possible to maintain $t < T$. For short display strings, the duty factor will then approach 20%.

FEATURES

- Four 0.150" Dot Matrix Characters
- Four Colors: Red, Yellow, High Efficiency Red, Green
- Wide Viewing Angle: X Axis +50°, Y Axis +75°
- Built-in CMOS Shift Registers with Constant Current LED Row Drivers
- Custom Fonts from Shift Registers
- Easily Cascaded for Multiple Displays
- TTL Compatible
- End Stackable
- Extended Operating Temperature Range: -40°C to + 85°C
- Categorized for Luminous Intensity
- All Displays Color Matched
- Compact Plastic Package
- 100% Burned-in and Tested

HDSP2000LP, HDSP2001LP, HDSP2002LP, HDSP2003LP

Ordering Information

Type	Color of Emission	Character Height [inch] ([mm])	Ordering Code
HDSP2000LP	red	0.150 (3.7)	Q68000A8131
HDSP2001LP	yellow		Q68000A8304
HDSP2002LP	high efficiency red		Q68000A8132
HDSP2003LP	green		Q68000A8133

Package Outlines

Dimensions in mm (inch)

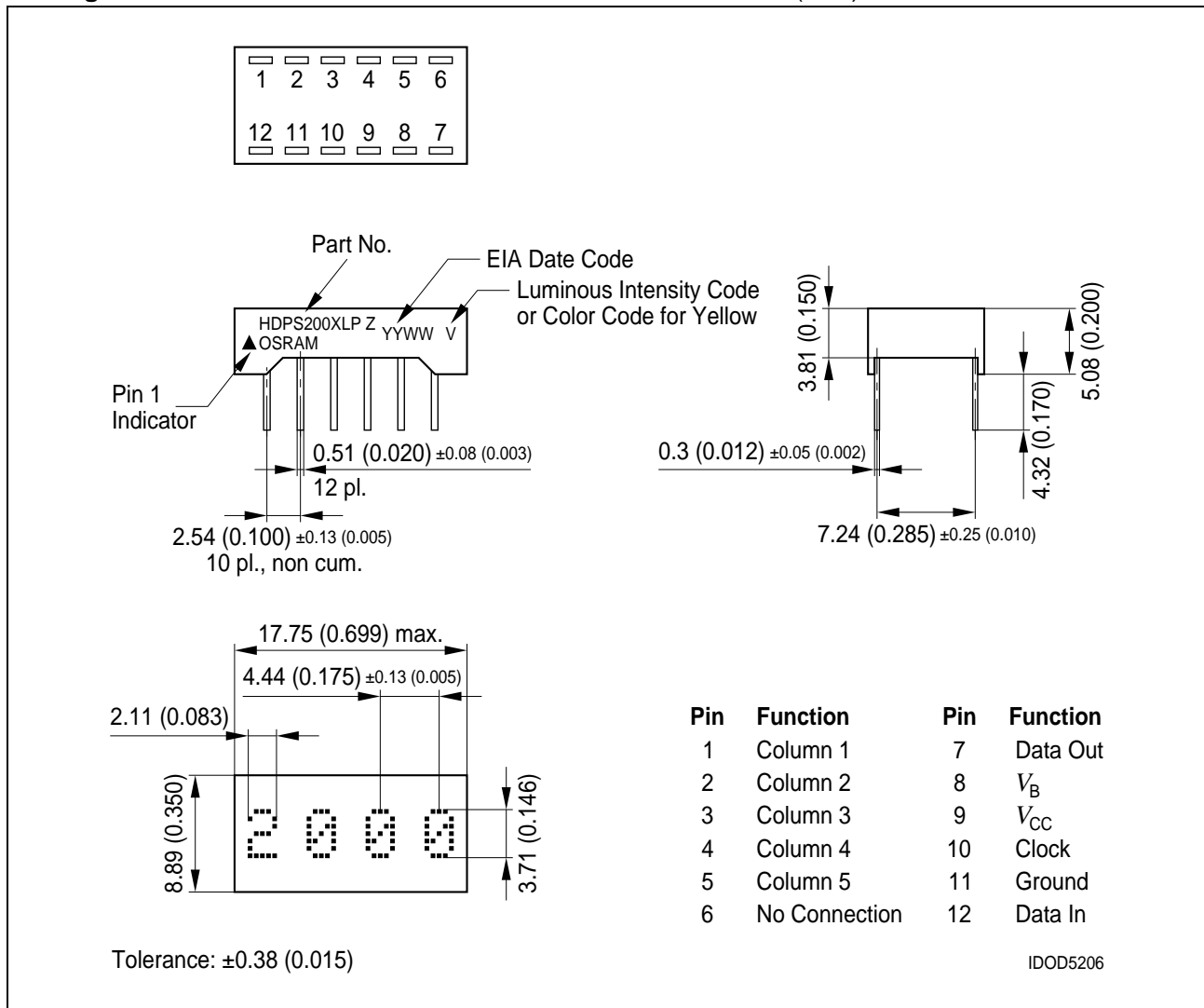

Maximum Ratings

Parameter	Symbol	Value	Unit
Operating temperature range	T_{op}	- 40 ... + 85	°C
Storage temperature range	T_{stg}	- 40 ... + 100	°C
DC Supply Voltage	V_{CC}	-0.5 to + 7.0	V
Inputs, Data Out and V_B		-0.5 to $V_{CC} + 0.5$	V
Column Input Voltage	V_{COL}	-0.5 to + 6.0	V
Solder temperature 063" (1.59 mm) below seating plane, $t < 5.0$ s	T_S	260	°C
Allowable Power Dissipation at $T_A=25^\circ\text{C}^1)$		0.86	W

¹⁾ Maximum allowable dissipation is derived from $V_{CC}=5.25$ V, $V_B=2.4$ V, $V_{COL}=3.5$ V, 20 LEDs on per character, 20% DF.

Maximum Allowable Power Dissipation vs. Temperature

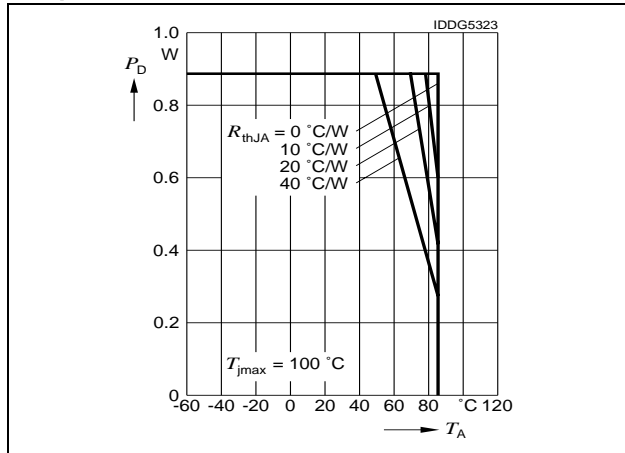

AC Electrical Characteristics

($V_{CC}=4.75$ to 5.25 V, $T_A=-40^\circ\text{C}$ to 85°C)

Symbol	Description	Min.	Max. ¹⁾	Units	Fig.
T_{SETUP}	Setup Time	50	—	ns	1
T_{HOLD}	Hold Time	25	—	ns	1
T_{WL}	Clock Width Low	75	—	ns	1
T_{WH}	Clock Width High	75	—	ns	1
$F_{(CLK)}$	Clock Frequency	0	5.0	MHz	1
T_{THL}, T_{TLH}	Clock Transition Time	—	200	ns	1
T_{PHL}, T_{PLH}	Propagation Delay Clock to Data Out	—	125	ns	1

¹⁾ V_B Pulse Width Modulation Frequency—50 kHz (max).

Timing Characteristics

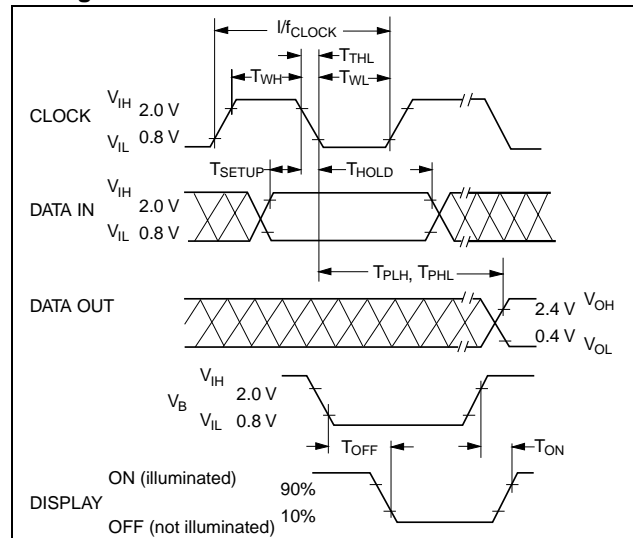

Peak Column Current vs. Column Voltage

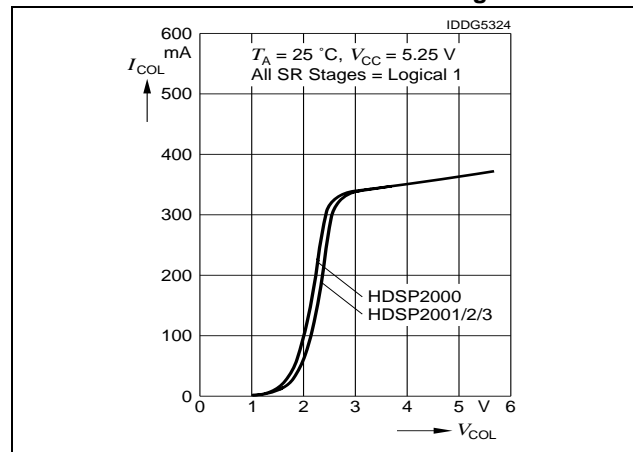

HDSP2000LP, HDSP2001LP, HDSP2002LP, HDSP2003LP

Recommended Operating Conditions

Parameter	Symbol	Min.	Typ.	Max.	Units
Supply Voltage	V_{CC}	4.75	5.0	5.25	V
Data Out Current, Low State	I_{OL}	—	—	1.6	mA
Data Out Current, High State	I_{OH}	-0.5	—	—	mA
Column Input Voltage, Column On HDSP2000LP ¹⁾	V_{COL}	2.4	—	3.5	V
Column Input Voltage, Column On, HDSP2001LP/2002LP/2003LP ¹⁾	V_{COL}	2.75	—	3.5	V
Setup Time	T_{SETUP}	70	—	—	ns
Hold Time	T_{HOLD}	30	—	—	ns
Width of Clock	$T_{W(CLK)}$	75	—	—	ns
Clock Frequency	T_{CLK}	—	—	5.0	MHz
Clock Transition Time	T_{THL}	—	—	200	ns

¹⁾ See Figure „Peak column current versus column voltage“ on **page 3**

Electrical characteristics (-40°C to +85°C, unless otherwise specified)

Description	Symbol	Min.	Typ. ¹⁾	Max.	Units	Test Conditions
Supply Current (quiescent)	V_{CC}	—	1	5	mA	$V_B=0.4\text{ V}$ $V_{CC}=5.25\text{ V}$ $V_{CLK}=V_{DATA}=2.4\text{ V}$ All SR Stages=Logical 1
		—	1	5	mA	$V_B=2.4\text{ V}$
Supply Current (operating)	V_{CC}	—	1.5	10.0	mA	$F_{CLK}=5.0\text{ MHz}$
Column Current at any Column Input ²⁾	i_{COL} (All)	—	—	10	μA	$V_B=0.4\text{ V}$ $V_{CC}=5.25\text{ V}$ $V_{COL}=3.5\text{ V}$ All SR Stages=Logical 1
	I_{COL}	—	335	410	mA	$V_B=2.4\text{ V}$
V_B , Clock or Data Input, Threshold Low	V_{IL}	—	—	0.8	V	$V_{CC}=4.75\text{ V}-5.25\text{ V}$
V_B , Clock or Data Input, Threshold High	V_{IH}	2.0	—	—	V	
Data Out Voltage	V_{OH}	2.4	—	—	V	$I_{OH}=-0.5\text{ mA}$ $V_{CC}=4.75\text{ V}$ $I_{COL}=0\text{ mA}$
	V_{OL}	—	—	0.4	V	$I_{OL}=1.6\text{ mA}$
Input Current Logical 0, V_B only	I_{IL}	-30	-110	-300	μA	$V_{CC}=4.75\text{ V}-5.25\text{ V}$, $V_{IL}=0.8\text{ V}$
Input Current Logical 0 Data, Clock	I_{IL}	—	-1	-10	μA	
Power Dissipation per Package ²⁾	P_D	—	0.4	—	W	$V_{CC}=5.0$, $V_{COL}=3.5\text{ V}$, 17.5% DF 15 LEDs on per character, $V_B=2.4\text{ V}$
Thermal Resistance IC Junction-to-Ambient	R_{qJ-A}	—	85	—	$^{\circ}\text{C/W/Device}$	

¹⁾ All typical values specified at $V_{CC}=5.0\text{ V}$ and $T_A=25^{\circ}\text{C}$ unless otherwise noted.

²⁾ See Figure „Peak column current versus column voltage“ on **page 3**

HDSP2000LP, HDSP2001LP, HDSP2002LP, HDSP2003LP

Optical Characteristics

Red HDSP2000LP

Description	Symbol	Min.	Typ. ⁴⁾	Units	Test Conditions
Peak Luminous Intensity per LED ^{1) 3)} (Character Average)	I_{Vpeak}	105	200	μcd	$V_{CC}=5.0\text{ V}$, $V_{COL}=3.5\text{ V}$, $T_J=25^\circ\text{C}$, $V_B=2.4\text{ V}$
Peak Wavelength	λ_{Vpeak}	—	655	nm	—
Dominant Wavelength ²⁾	λ_{dom}	—	639	nm	—

Yellow HDSP2001LP

Description	Symbol	Min.	Typ. ⁴⁾	Units	Test Conditions
Peak Luminous Intensity per LED ^{1) 3)} (Character Average)	I_{Vpeak}	400	1140	μcd	$V_{CC}=5.0\text{ V}$, $V_{COL}=3.5\text{ V}$, $T_J=25^\circ\text{C}$, $V_B=2.4\text{ V}$
Peak Wavelength	λ_{Vpeak}	—	583	nm	—
Dominant Wavelength ²⁾	λ_{dom}	—	585	nm	—

High Efficiency Red HDSP2002LP

Description	Symbol	Min.	Typ. ⁴⁾	Units	Test Conditions
Peak Luminous Intensity per LED ^{1) 3)} (Character Average)	I_{Vpeak}	400	1430	μcd	$V_{CC}=5.0\text{ V}$, $V_{COL}=3.5\text{ V}$, $T_J=25^\circ\text{C}$, $V_B=2.4\text{ V}$
Peak Wavelength	λ_{Vpeak}	—	635	nm	—
Dominant Wavelength ²⁾	λ_{dom}	—	626	nm	—

Green HDSP2003LP

Description	Symbol	Min.	Typ. ⁴⁾	Units	Test Conditions
Peak Luminous Intensity per LED ^{1) 3)} (Character Average)	I_{Vpeak}	650	1550	μcd	$V_{CC}=5.0\text{ V}$, $V_{COL}=3.5\text{ V}$, $T_J=25^\circ\text{C}$, $V_B=2.4\text{ V}$
Peak Wavelength	λ_{Vpeak}	—	565	nm	—
Dominant Wavelength ²⁾	λ_{dom}	—	569	nm	—

Notes:

¹⁾ The displays are categorized for luminous intensity with the intensity category designated by a letter code on the bottom of the package.

²⁾ Dominant wavelength (λ_{dom}) is derived from the CIE chromaticity diagram and represents the single wavelength which defines the color of the device.

³⁾ The luminous sterance of the LED may be calculated using the following relationships:

$$L_v (\text{cd/m}^2) = I_v (\text{Candela}) / A (\text{Meter})^2$$

$$L_v (\text{Footlamberts}) = p I_v (\text{Candela}) / A (\text{Foot})^2$$

$$\text{HDSP2000LP, } A = 5.58 \times 10^{-8} \text{ m}^2 = 6 \times 10^{-7} \text{ ft.}^2$$

$$\text{HDSP2001/2/3LP, } A = 7.8 \times 10^{-8} \text{ m}^2 = 8.4 \times 10^{-7} \text{ ft.}^2$$

⁴⁾ All typical values specified at $V_{CC}=5.0\text{ V}$ and $T_A=25^\circ\text{C}$ unless otherwise noted.

HDSP2000LP, HDSP2001LP, HDSP2002LP, HDSP2003LP

Block Diagram

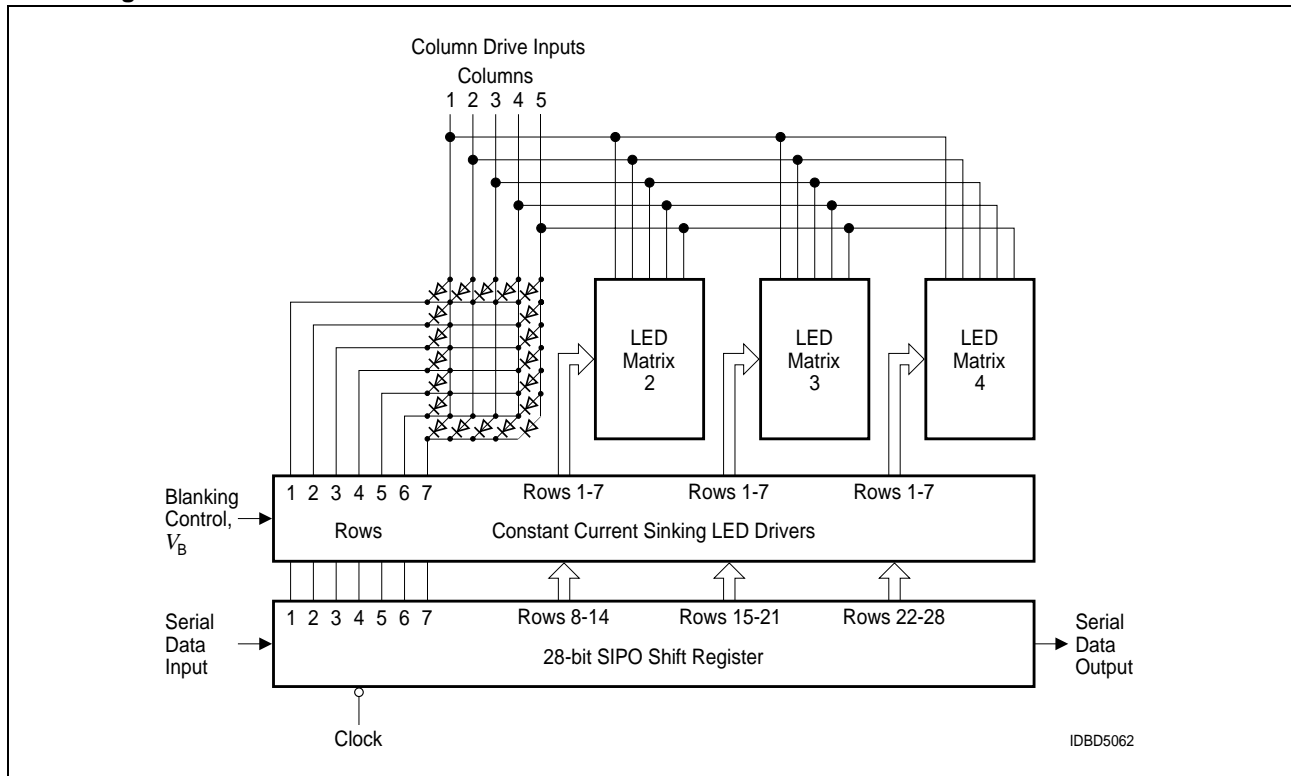

Contrast Enhancement Filters

Display Color	Ambient Lighting		
	Dim	Moderate	Bright
Red HDSP2000LP	Panelgraphic Dark Red 63 Panelgraphic Ruby Red 60 Chequers Red 118 Plexiglass 2423	Polaroid HNCP37 3M Light Control Film Panelgraphic Gray 10 Chequers Gray 105	—
Yellow HDSP2001LP	Panelgraphic Yellow 27		Polaroid HNCP 10-Glass* Marks Polarized MPC 30-25C**
HER HDSP2002LP	Panelgraphic Ruby Red 60 Chequers Red 112		Polaroid HNCP 10-Glass* Marks Polarized MPC 20-15C**
Green HDSP2003LP	Panelgraphic Green 48 Chequers Green 107		Polaroid HNCP 10-Glass* Marks Polarized MPC 50-12C**

Note:

1. Optically coated circular polarized filters, such as Polaroid HNCP10.

*Polaroid Corp.
1 Upland Rd., Bldg. #2
Norwood, MA 02062
800/225-2770

**Marks Polarized Corp.
25-B Jefryn Blvd. W
Deer Park, NY 11729
516/242-1300
FAX 516/242-1347
Marks Polarized Corp. manufactures
to MIL-1-45208 inspection system.

General Quality Assurance Levels

Generic data available.

2009-03-31

6

Opto Semiconductors

OSRAM

Thermal Considerations

The small alphanumeric displays are hybrid LED and CMOS assemblies that are designed for reliable operation in commercial, industrial, and military environments. Optimum reliability and optical performance will result when the junction temperature of the LEDs and CMOS ICs are kept as low as possible.

Thermal Modeling

HSDP200XLP consist of two driver ICs and four 5 x 7 LED matrixes. A thermal model of the display is shown in Figure „Thermal Model“. It illustrates that the junction temperature of the semiconductor = junction self heating + the case temperature rise + the ambient temperature.

Equation 1 shows this relationship.

Thermal Model

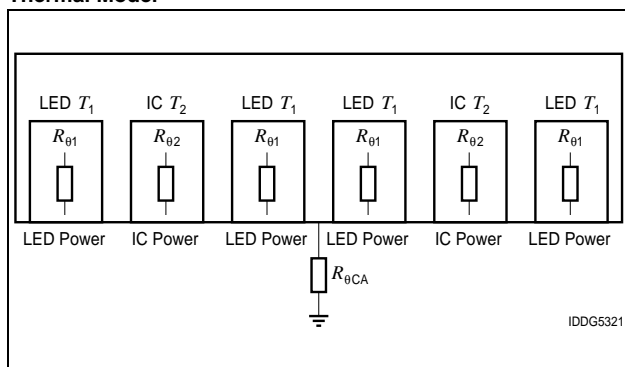

See Equation 1 below.

The junction rise within the LED is the product of the thermal impedance of an individual LED (37°C/W, DF=20%, F=200 Hz), times the forward voltage, $V_{F(LED)}$, and forward current $I_{F(LED)}$, of 13 – 14.5 mA. This rise averages $T_{J(LED)}=1^{\circ}\text{C}$. The Table below shows the $V_{F(LED)}$ for the respective displays.

Model Number	VF		
	Min.	Typ.	Max.
HDSP2000LP	1.6	1.7	2.0
HSDP2001/2/3LP	1.9	2.2	3.0

The junction rise within the LED driver IC is the combination of the power dissipated by the IC quiescent current and the 28 row driver current sinks. The IC junction rise is given in Equation 2.

A thermal resistance of 28°C/W results in a typical junction rise of 6°C.

See Equation 2 below.

Equation 1.

$$T_{J(LED)} = P_{LED} Z_{\theta JC} + P_{CASE} (R_{\theta JC} + R_{\theta CA}) + T_A$$

$$T_{J(LED)} = [(I_{COL}/28)V_{F(LED)} Z_{\theta JC}] + [(n/35)I_{COL} DF (5V_{COL}) + V_{CC} I_{CC}] \cdot [R_{\theta JC} + R_{\theta CA}] + T_A$$

Equation 2.

$$T_{J(IC)} = P_{COL} (R_{\theta JC} + R_{\theta CA}) + T_A$$

$$T_{J(IC)} = [5(V_{COL} - V_{F(LED)}) \cdot (I_{COL}/2) \cdot (n/35)DF + V_{CC} \cdot I_{CC}] \cdot [R_{\theta JC} + R_{\theta CA}] + T_A$$

For ease of calculations the maximum allowable electrical operating condition is dependent upon the aggregate thermal resistance of the LED matrixes and the two driver ICs. All of the thermal management calculations are based upon the parallel combination of these two networks which is 15°C/W. Maximum allowable power dissipation is given in Equation 3.

Equation 3.

$$P_{DISPLAY} = \frac{T_{J(MAX)} - T_A}{R_{\theta JC} + R_{\theta CA}}$$

$$P_{DISPLAY} = 5V_{COL} I_{COL} (n/35) DF + V_{CC} I_{CC}$$

For further reference see Figures „Maximum Allowable Power Dissipation vs. Temperature“ (page 3) and Figures from page 8 on.

Key to equation symbols

DF	Duty factor
I_{CC}	Quiescent IC current
I_{COL}	Column current
n	Number of LEDs on in a 5 x 7 array
P_{CASE}	Package power dissipation excluding LED under consideration
P_{COL}	Power dissipation of a column
$P_{DISPLAY}$	Power dissipation of the display
P_{LED}	Power dissipation of a LED
R_{qCA}	Thermal resistance case to ambient
R_{qJC}	Thermal resistance junction to case
T_A	Ambient temperature
$T_{J(IC)}$	Junction temperature of an IC
$T_{J(LED)}$	Junction temperature of a LED
$T_{J(MAX)}$	Maximum junction temperature
V_{CC}	IC voltage
V_{COL}	Column voltage
$V_{F(LED)}$	Forward voltage of LED
Z_{qJC}	Thermal impedance junction to case

Optical Considerations

The light output of the LEDs is inversely related to the LED diode's junction temperature as shown in Figure „Normalized Luminous Intensity vs. Junction Temperature“. For optimum light output, keep the thermal resistance of the socket or PC board as low as possible.

Normalized Luminous Intensity vs. Junction Temperature

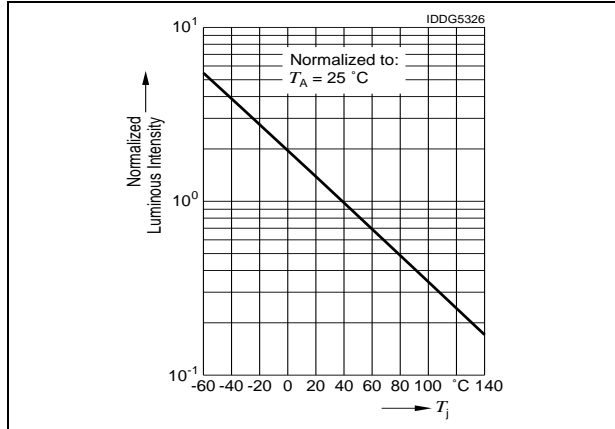

When mounted in a 10 °C/W socket and operated at Absolute Maximum Electrical conditions, the HDSP200XLP will show an LED junction rise of 17 °C. If $T_A = 40$ °C, then the LED's T_j will be 57 °C. Under these conditions the following figure shows that the I_v will be 75% of its 25 °C value.

Maximum LED Junction Temperature vs. Socket Thermal Resistance

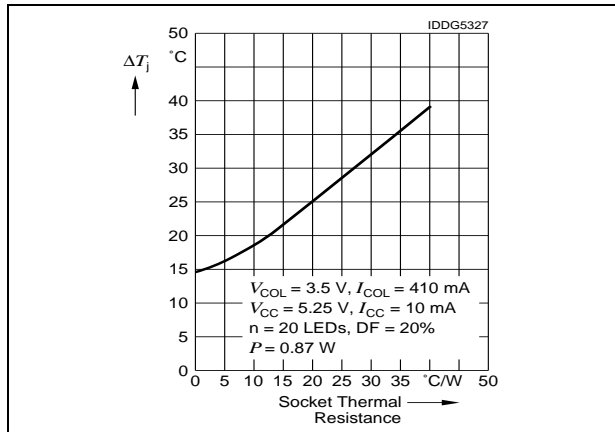

Maximum Package Power Dissipation

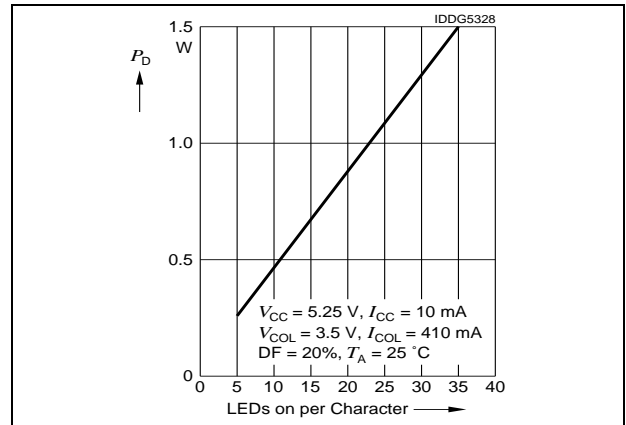

Package Power Dissipation

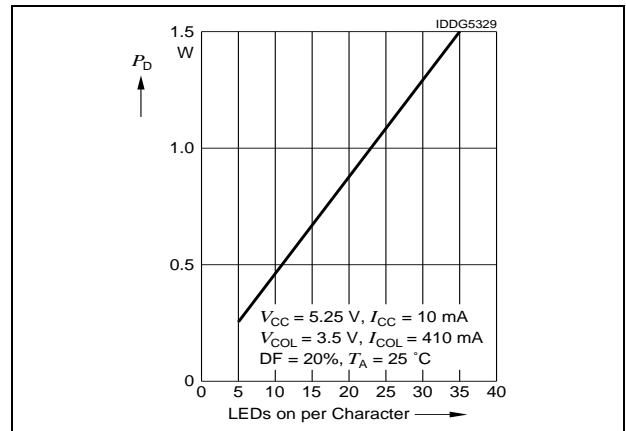

Maximum Character Power Dissipation

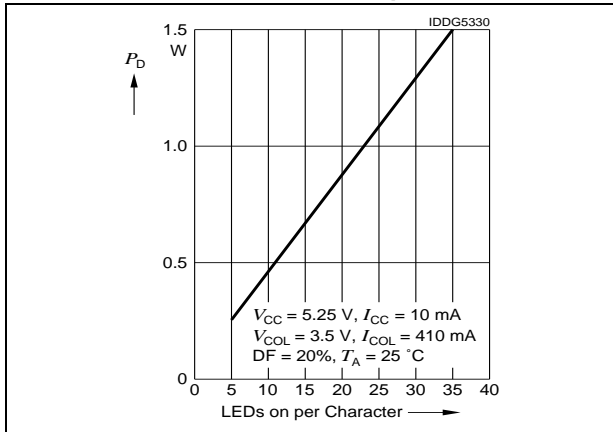

Soldering Considerations

The HDSP200xLP can be hand soldered using a grounded iron set to 260°C.

The display is compatible with leadfree and tin/lead solder. Wave soldering is also possible following these conditions. Preheat does not exceed 93°C on the solder side of the PC board or a package surface temperature of 85°C. Water soluble organic acid flux (except carboxylic acid) or resin-based RMA flux without alcohol can be used.

Wave temperature of 245°C +/-5°C with a dwell between 1.5 sec. to 3 sec. Exposure to the wave should not exceed temperatures above 260°C for five seconds at 0.063 inches below the seating plane. The packages should not be immersed in the wave.

Character Power Dissipation

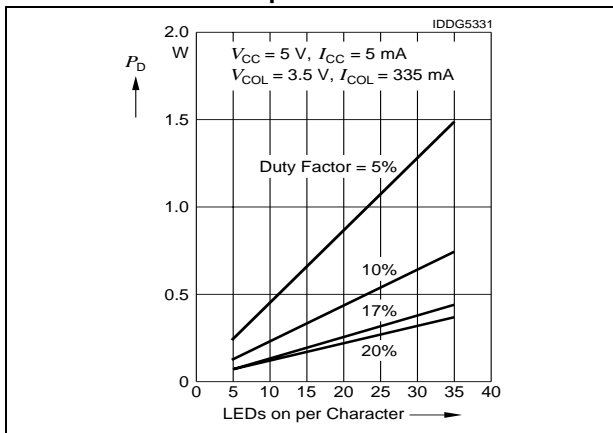

Revision History: 2009-03-31

Previous Version: 2008-09-03

Page	Subjects (major changes since last revision)	Date of change
all	Lead free device	2006-01-23
	update of outline drawing	2008-09-03
2	ordering code corrected	2009-03-31

Cleaning the Displays

IMPORTANT—Do not use cleaning agents containing alcohol of any type with this display. The least offensive cleaning solution is hot D.I. water (60°C) for less than 15 minutes. Addition of mild saponifiers is acceptable. Do not use commercial dishwasher detergents.

For post solder cleaning use water or non-alcohol mixtures formulated for vapor cleaning processing or non-alcohol mixtures formulated for room temperature cleaning. Nonalcohol vapor cleaning processing for up to two minutes in vapors at boiling is permissible. For suggested solvents refer to Appnote 19 at www.osram-os.com

Published by
OSRAM Opto Semiconductors GmbH
 Leibnizstrasse 4, D-93055 Regensburg
www.osram-os.com
 © All Rights Reserved.

Attention please!

The information describes the type of component and shall not be considered as assured characteristics. Terms of delivery and rights to change design reserved. Due to technical requirements components may contain dangerous substances. For information on the types in question please contact our Sales Organization. If printed or downloaded, please find the latest version in the Internet.

Packing

Please use the recycling operators known to you. We can also help you – get in touch with your nearest sales office. By agreement we will take packing material back, if it is sorted. You must bear the costs of transport. For packing material that is returned to us unsorted or which we are not obliged to accept, we shall have to invoice you for any costs incurred.

Components used in life-support devices or systems must be expressly authorized for such purpose! Critical components¹⁾ may only be used in life-support devices or systems²⁾ with the express written approval of OSRAM OS.

¹⁾ A critical component is a component used in a life-support device or system whose failure can reasonably be expected to cause the failure of that life-support device or system, or to affect its safety or the effectiveness of that device or system.

²⁾ Life support devices or systems are intended (a) to be implanted in the human body, or (b) to support and/or maintain and sustain human life. If they fail, it is reasonable to assume that the health and the life of the user may be endangered.