

UNCONTROLLED DOCUMENT

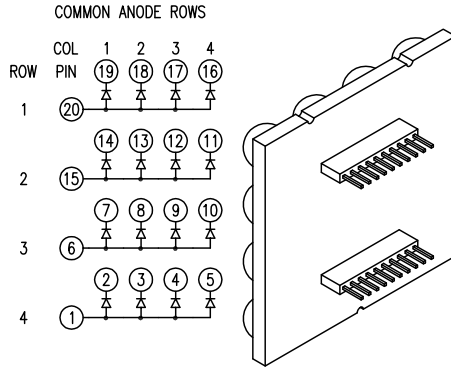
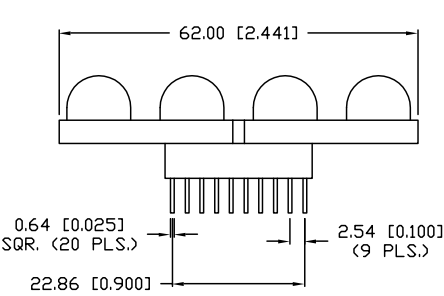
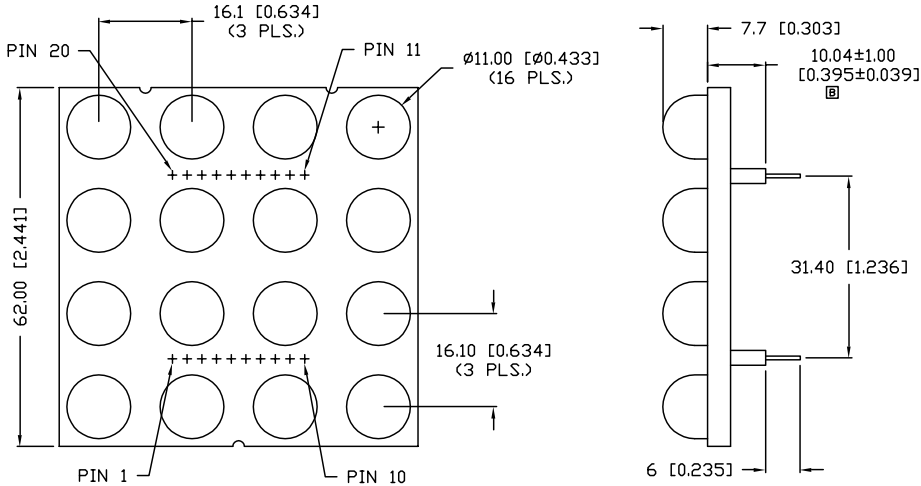

PART NUMBER		REV.
SSP-LXS2442UP16A		B
REV.	E.C.N. NUMBER AND REVISION COMMENTS	DATE
A	E.C.N. #10582.	1.19.00
B	E.C.N. #10694.	12.14.00

ELECTRO-OPTICAL CHARACTERISTICS T _A =25°C I _f =20mA					
PARAMETER	MIN	TYP	MAX	UNITS	TEST COND
PEAK WAVELENGTH		525		nm	
FORWARD VOLTAGE		3.5	4.0	V _f	
REVERSE VOLTAGE	5.0			V _r	I _r =100μA
AXIAL INTENSITY**		5000		mcd	I _f =20mA
VIEWING ANGLE		30		2x theta	
EMITTED COLOR:	GREEN				
EPOXY LENS FINISH:	WATER CLEAR				

** INTENSITY PER DIE.

LIMITS OF SAFE OPERATION AT 25°C PER DIE

PARAMETER	MAX	UNITS
PEAK FORWARD CURRENT*	100	mA
STEADY CURRENT	30	mA
POWER DISSIPATION	98	mW
DERATE FROM 25°C	-1.2	mW/°C
OPERATING, STORAGE TEMP.	-30 TO +70	°C
SOLDERING TEMP.	+260	°C
2.0mm FROM BODY		3 SEC. MAX

* t<10μs

CAUTION: STATIC SENSITIVE DEVICE
 FOLLOW PROPER E.S.D. HANDLING PROCEDURES
 WHEN WORKING WITH THIS PART.
 ESD CLASSIFICATION: CLASS II BASED ON MIL-STD 883E.

UNCONTROLLED DOCUMENT

*UNLESS OTHERWISE SPECIFIED TOLERANCES PER DECIMAL PRECISION ARE: X=±1 (±0.039), X.X=±0.5 (±0.020), X.XX=±0.25 (±0.010), X.XXX=±0.127 (±0.005). LEAD SIZE=±0.05 (±0.002), LEAD LENGTH=±0.75 (±0.030), MIN.=+DECIMAL PRECISION -0.00, MAX.=+0.00 -DECIMAL PRECISION

REV. B	PART NUMBER SSP-LXS2442UP16A
2.44" SQUARE, 16 LED CLUSTER, 525nm ULTRA GREEN LEDS, WATER CLEAR LENS, COMMON ANODE ROWS.	

CONFIDENTIAL INFORMATION
 THE INFORMATION CONTAINED IN THIS DOCUMENT IS THE PROPERTY OF LUMEX INC. EXCEPT AS SPECIALLY AUTHORIZED IN WRITING BY LUMEX INC., THE HOLDER OF THIS DOCUMENT SHALL KEEP ALL INFORMATION CONTAINED HEREIN CONFIDENTIAL AND SHALL PROTECT SAME IN WHOLE OR IN PART FROM DISCLOSURE AND DISSEMINATION TO ALL THIRD PARTIES.

RELIABILITY NOTE
 OUR MANY YEARS OF EXPERIENCE DATA ACCUMULATION INDICATE THAT SOLDER HEAT IS A MAJOR CAUSE OF EARLY AND FUTURE FAILURE. PLEASE PAY ATTENTION TO YOUR SOLDERING PROCESS.

		290 E. HELEN ROAD PALATINE, IL 60067-6976 PHONE: +1.847.359.2790 US WEB: www.lumex.com TW WEB: www.lumex.com.tw	
DRAWN BY: CT	CHECKED BY:	APPROVED BY:	DATE: 9.21.99 PAGE: 1 OF 1 SCALE: N/A