

# HDSM-531W/533W

0.56inch (14.0mm)

Single digit surface mount LED display



## Data Sheet

### Description

This is 0.56" (14.22mm) height single digit display. This device utilizes white ChipLED. This device comes with top surface gray and white segments.

White HDSM-	Description
531W	Common Anode, Right Hand Decimal
533W	Common Cathode, Right Hand Decimal

### Features

- 0.56" digit height
- Low current operation
- Excellent characters appearance
- Available in CA and CC
- 1000 pieces per reel
- Moisture Sensitivity Level: Level 3
- RoHS compliant

### Package Dimensions

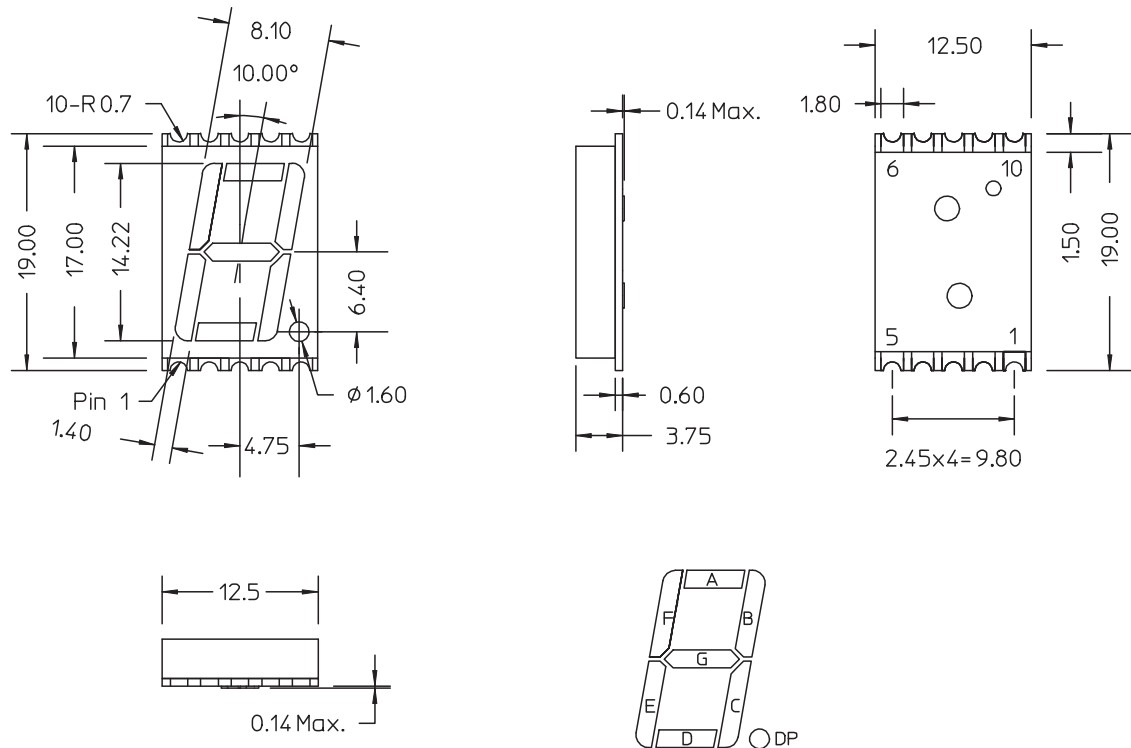

### Notes:

All dimensions are in millimeters (inches).  
Tolerance:  $\pm 0.25\text{mm}$  (0.01") unless otherwise noted.

**CAUTION:** LEDs are Class 1A ESD sensitive per JESD22-A114C.01.  
Please observe appropriate precautions during handling and processing.

### Pin Connection (Common Anode)

Pin No.	Connection
1	CATHODE E
2	CATHODE D
3	COMMON ANODE
4	CATHODE C
5	CATHODE DP
6	CATHODE B
7	CATHODE A
8	COMMON ANODE
9	CATHODE F
10	CATHODE G

### Pin Connection (Common Cathode)

Pin No.	Connection
1	ANODE E
2	ANODE D
3	COMMON CATHODE
4	ANODE C
5	ANODE DP
6	ANODE B
7	ANODE A
8	COMMON CATHODE
9	ANODE F
10	ANODE G

### Internal Circuit Diagram (Common Anode)

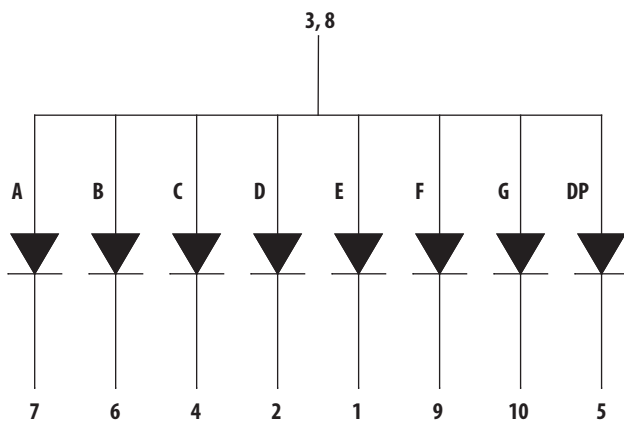

### Internal Circuit Diagram (Common Cathode)

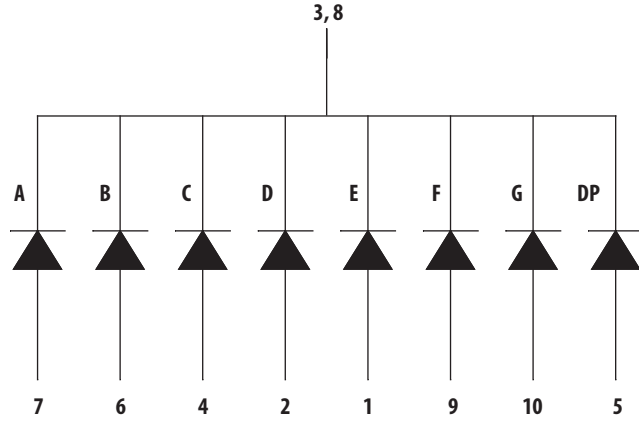

**Absolute Maximum Ratings @ T<sub>A</sub>=25°C**

Parameter	White	Unit
Power Dissipation Per Segment	39	mW
Peak Forward Current Per Segment (1/10 Duty Cycle, 0.1ms pulse width)	80	mA
Continuous Forward Current Per Segment Derating Linearly From 25°C Per Segment	25 0.25	mA mA/°C
Reverse Voltage Per Segment	5	V
Operating Temperature Range		-40°C to +105°C
Storage Temperature Range		-40°C to +105°C

**Electrical / Optical Characteristics @ T<sub>A</sub>=25°C****White**

Parameter	Symbol	Min.	Typ.	Max.	Unit	Test Condition
Average Luminous Intensity	I <sub>V</sub>	28	44	–	mcd	I <sub>F</sub> = 5 mA
Chromaticity Coordinates	(X,Y)		Refer to Figure 1			I <sub>F</sub> = 5 mA
Forward Voltage, Per Segment	V <sub>F</sub>	–	2.95	3.8	V	I <sub>F</sub> = 5 mA
Reverse Current, Per Segment	I <sub>R</sub>	–	–	100	μA	V <sub>R</sub> = 5 V
Luminous Intensity Matching Ratio	I <sub>V-m</sub>	–	–	2:1	–	I <sub>F</sub> = 5 mA

Typical Electrical / Optical characteristic Curves @  $T_A=25^\circ\text{C}$

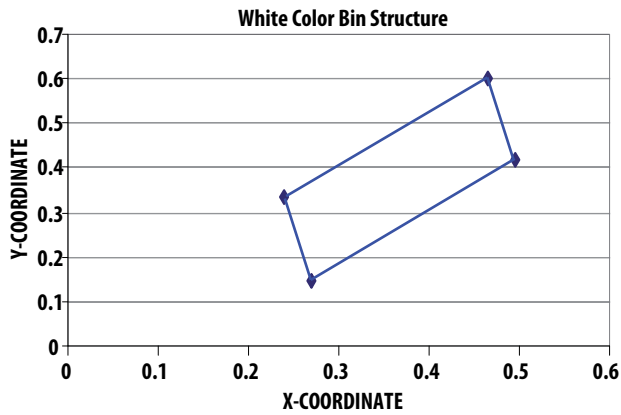

Figure 1. Color bin limit (CIE 1931 Chromatically Diagram)  
[Tolerance: +/-0.02]

Chromaticity Coordinates				
X	0.24	0.495	0.269	0.465
Y	0.332	0.418	0.147	0.602

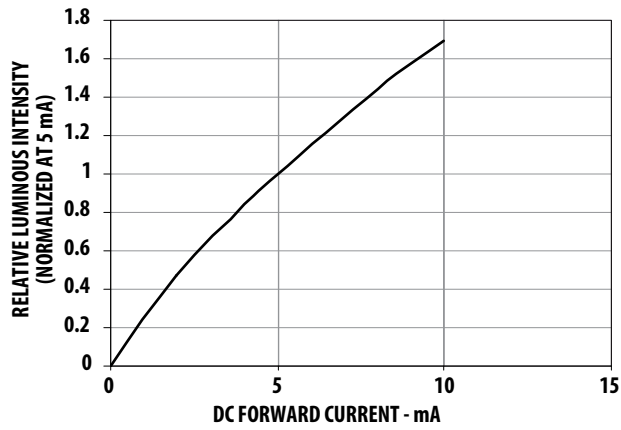

Figure 2. Relative luminous intensity versus forward current

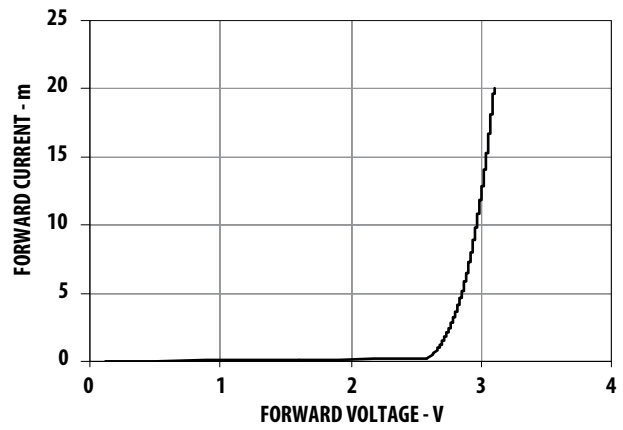

Figure 3. Forward current versus forward voltage

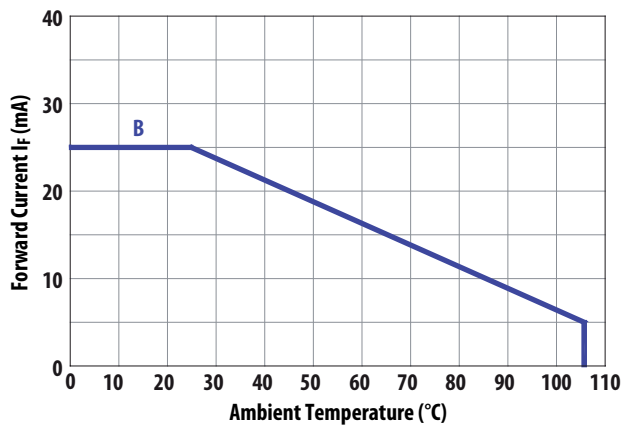
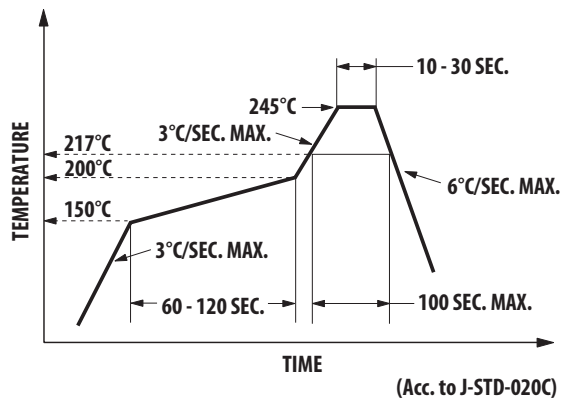

Figure 4. Allowable DC Current Versus Ambient Temperature

## SMT Soldering Profile

### Pb free reflow soldering Profile



#### Notes:

1. The peak temperature refers to the peak package body temperature.
2. Number of reflow process shall be limited to maximum 2 times only. Cooling process to normal temperature is required between first and second soldering process.

## Recommended Soldering Pattern (unit: mm)

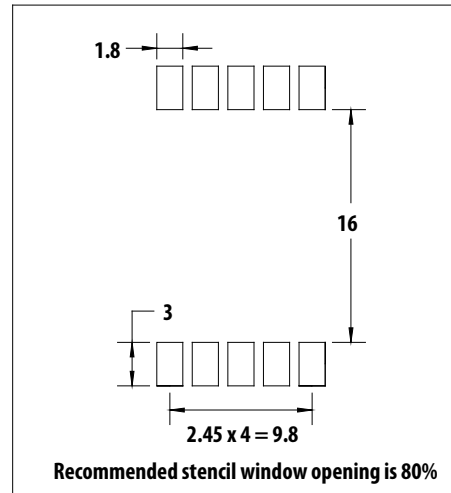

## Tape Specification (unit: mm)

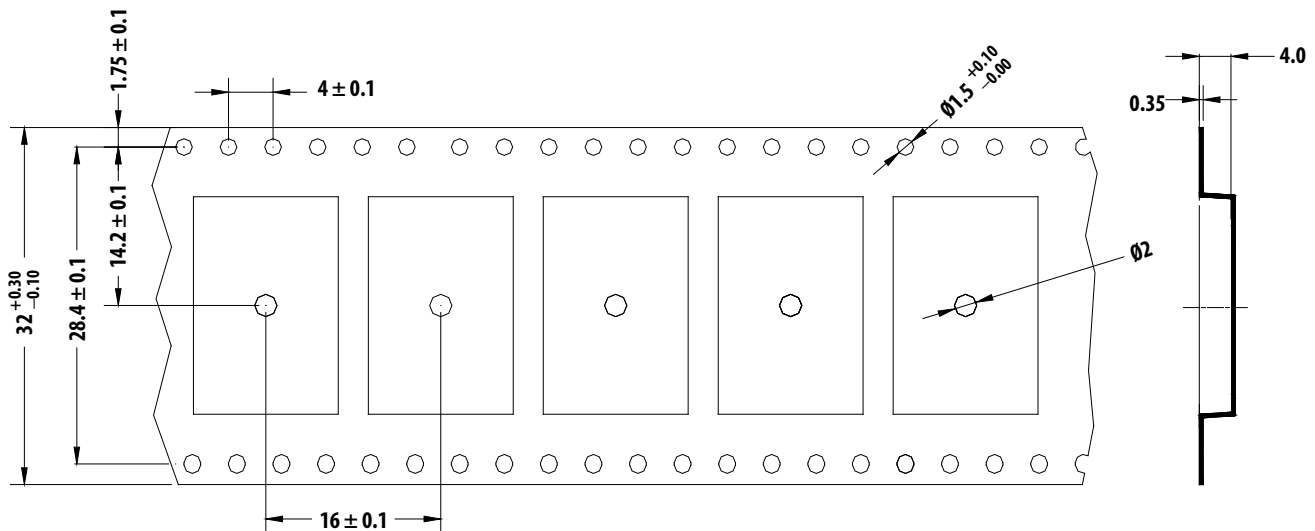

For product information and a complete list of distributors, please go to our web site: [www.avagotech.com](http://www.avagotech.com)

Avago, Avago Technologies, and the A logo are trademarks of Avago Technologies in the United States and other countries. Data subject to change. Copyright © 2005-2011 Avago Technologies. All rights reserved. AV02-1642EN - March 17, 2011

**AVAGO**  
TECHNOLOGIES