

<div style="border: 1px solid black; border-radius: 15px; padding: 5px; display: inline-block;"> LCD Module Specification </div>	First Edition	Approved by <i>A. Kamen</i>	Production Div.
	May 2, 2000	Checked by	Quality Assurance Div.
	Final Revision	<i>Z. Katsun</i>	
	*****	Checked by <i>S. Matsukawa</i>	Design Engineering Div.
Type No.	F - 5 1 1 6 7 NCU - FW - AB		Prepared by <i>Y. Kuragano</i>
			Production Div.

Table of Contents

1. General Specifications	2
2. Electrical Specifications.....	3
3. Optical Specifications	8
4. I/O Terminal.....	10
5. Test.....	12
6. Appearance Standards.....	13
7. Code System of Production Lot.....	15
8. Type Number	15
9. Applying Precautions.....	15
10. Precautions Relating Product Handling	16
11. Warranty.....	17

Revision History

Rev.	Date	Page	Comment

Downloaded from Elcodis.com electronic components distributor

1. General Specifications

Operating Temp.	: min. 0°C ~ max. 50°C
Storage Temp.	: min. -20°C ~ max. 70°C
Dot Pixels	: 320×3 [R.G.B] (W) × 240 (H) dots
Dot Size	: 0.10 (W) × 0.34 (H) mm
Dot Pitch	: 0.12 (W) × 0.36 (H) mm
Viewing Area	: 122.0 (W) × 92.0 (H) mm
Outline Dimensions	: 167.1* (W) × 109.0 (H) × 8.0 max. (D) mm * Without CFL Cable
Weight	: 204g max.
LCD Type	: CTD-17753 (F-STN / Color-mode / Transmissive)
Viewing Angle	: 12:00
Data Transfer	: 8-bit parallel data transfer
Duty	: 1/240 Duty
Backlight	: Cold Cathode Fluorescent Lamp (CFL) × 1
Additional Spec.	: Wide Viewing Type
Drawings	: Dimensional Outline UE-300830

2. Electrical Specifications

2.1. Absolute Maximum Ratings

GND=0V

Parameter	Symbol	Conditions	Min.	Max.	Units
Supply Voltage (Logic)	V _{CC1-GND}	—	-0.3	7.0	V
Supply Voltage (LCD Drive)	V _{CC2-GND}	—	0	6.0	V
Input Voltage	V _I	—	-0.3	V _{CC1} +0.3	V
V _{CONT} Input Voltage	V _{CONT-GND}	—	0	3.0	V

2.2. DC Characteristics

T_a=25°C, GND=0V

Parameter	Symbol	Conditions	Min.	Typ.	Max.	Units
Supply Voltage (Logic)	V _{CC1-GND}	—	3.0	—	5.5	V
Supply Voltage (LCD Drive)	V _{CC2-GND}	—	3.0	—	5.5	V
Voltage for Contrast Adjustment (Note1)	V _{CONT-GND}	—	0.8	—	2.7	V
High Level Input Voltage	V _{IH}	V _{CC1} =3.0~5.5V	0.8 × V _{CC1}	—	V _{CC1}	V
Low Level Input Voltage	V _{IL}	V _{CC1} =3.0~5.5V	0	—	0.2 × V _{CC1}	V
Supply Current (Note2)	I _{CC}	V _{CC1-GND} =5.0V V _{CC2-GND} =5.0V	—	40.0	60.0	mA
Clock Frequency	f _{CP}	V _{CC1} =2.7~5.5V Duty=50%	—	—	30	MHz

Note1: The relation between Voltage for Contrast Adjustment and LCD Contrast is shown as follows;
0.8V(Bright)~2.7V(dark)

Note2: Supply current which checker pattern displayed.

$$I_{CC} = I_{CC1} + I_{CC2}$$

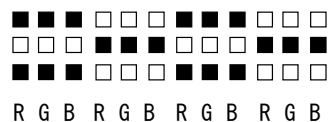

f_F=70Hz

V_D=24.5

2.3. AC Characteristics

V_{CC1}=2.7~5.5V

Parameter	Symbol		Min.	Max.	Units
LP Cycle Time	t _{LP}	—	5	—	ns
LP High Level Width	t _{WLH}	—	40	—	ns
LP Low Level Width	t _{WLL}	—	1000	—	ns
Rise/Fall Time	t _r , t _d	Note 1	—	6.6	ns
FLM Setup Time	t _{st}	—	60	—	ns
FLM Hold Time	t _{hd}	—	30	—	ns
CP Cycle Time	t _{CP}	—	40	—	ns
CP High Level Width	t _{WCH}	—	15	—	ns
CP Low Level Width	t _{WCL}	—	15	—	ns
LP Setup Time 1	t _{st1}	—	30	—	ns
LP Setup Time 2	t _{st2}	—	30	—	ns
LP Hold Time	t _{hd1}	—	15	—	ns
Data Setup Time	t _{st3}	—	15	—	ns
Data Hold Time	t _{hd2}	—	15	—	ns
LP ↑ to CP ↑	t _{LH}	—	25	—	ns
LP ↓ to CP ↓	t _{LS}	—	25	—	ns
DISPOFF Low Level Width	t _{WDL}	—	100	—	ns
DISPOFF Cancellation Time	t _{SD}	—	20	—	ns

Note 1: The rise and fall times (t_r, t_f) must satisfy the following relationships.

$$t_r, t_f \leq (1/f - 2 \times t_w) / 2 \quad f : \text{frequency} \quad t_w : \text{Minimum pulse width}$$

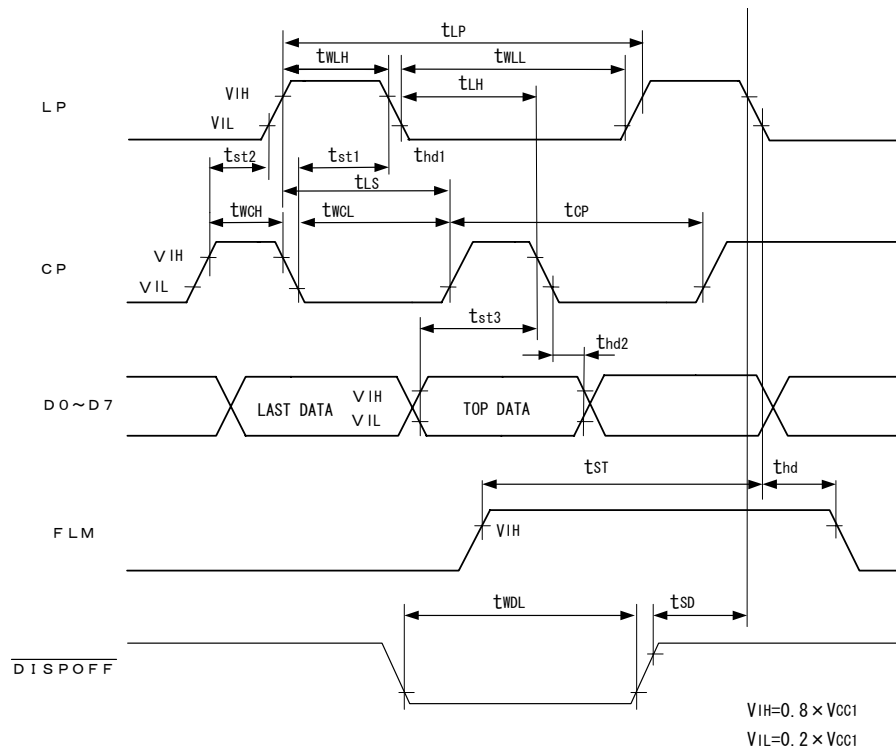

2.4. Timing Chart

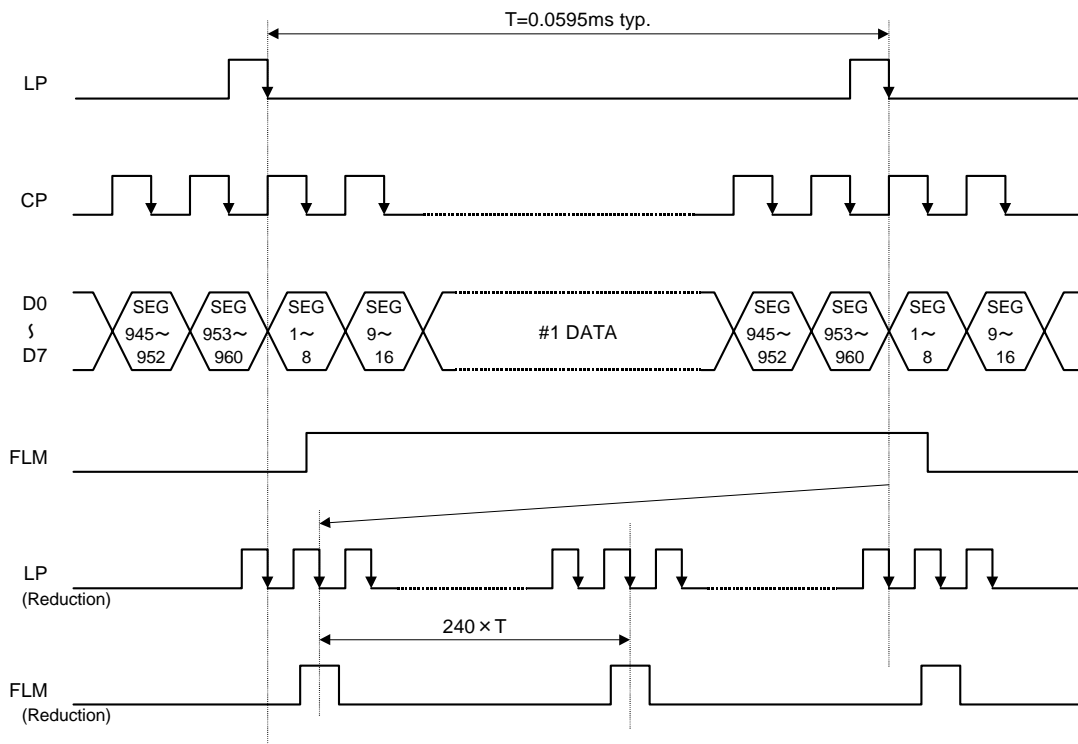

2.5. Comparison of Display and Data

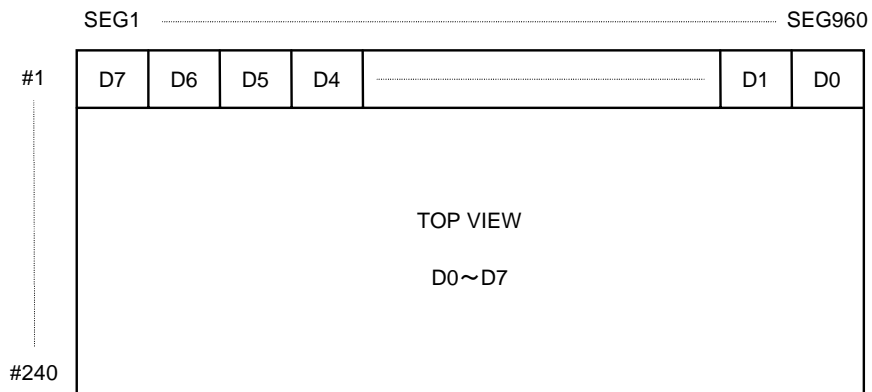

2.6. Power Supply ON/OFF Sequence

2.6.1. ON Sequence

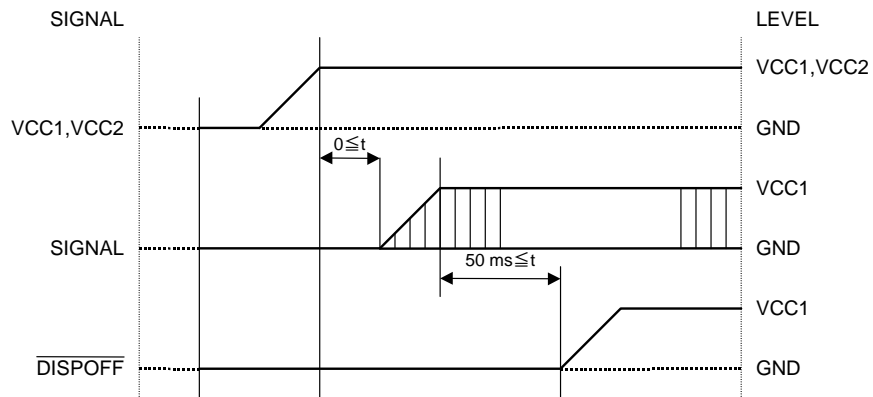

2.6.2. OFF Sequence

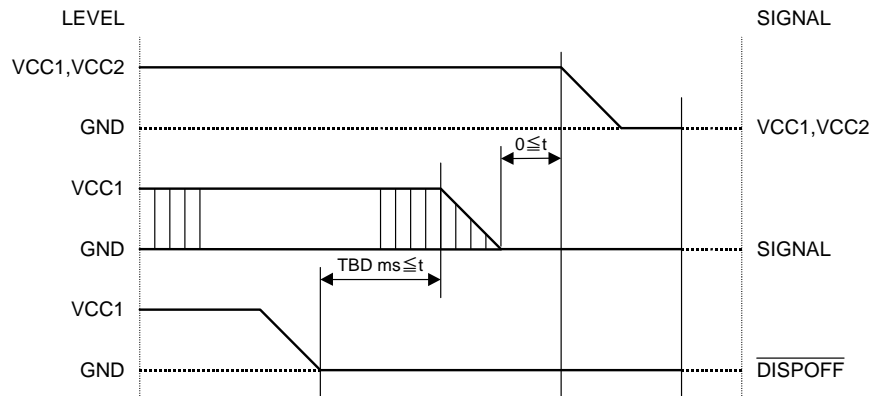

Please maintain the above sequence when turning on and off the power supply of the module. If $\overline{\text{DISPOFF}}$ is supplied to the module while internal alternate signal for LCD driving (M) is unstable, DC component will be supplied to the LCD panel. This may cause damage the LCD module.

2.7. Lighting Specifications

Ta=25°C

Parameter	Symbol	Conditions	Min.	Typ.	Max.	Units	Notes
Lamp Voltage	V _L	—	—	430	—	V _{rms}	1
Lamp Current	I _L	—	4.0	5.0	6.0	mArms	2
Starting Voltage	V _S	—	—	—	700	V _{rms}	3
Surface Luminance	L	I _L = 5.0 mA	80	120	—	cd/m ²	4
Average Life	T _{AL}	I _L = 5.0 mA	20000	—	—	hrs	5

Note 1 : The voltage (r.m.s.) to maintain the electric discharge of the lamp. It is measured after lighting for 3 minutes .

Note 2 : The current (r.m.s.) to flow through the lamp with the electric discharge. It is measured after lighting for 3 minutes.

Note 3 : The voltage at starting the electric discharge when the voltage is increased gradually from 0V.

Note 4 : Surface Luminance is specified by the average of 9 luminance values measured at each point shown above after 20 minutes power on with the all ON pattern adjusted to maximum contrast and the dimming control of 100%. (maximum brightness)

Note 5 : CFL life is defined as the time for which the initial luminance is attenuated by 50% of the luminance value. Average Life represents the time elapsed at the point of time when the residual ratio becomes below 50% when plural lamps are lighted in comparison with the definition of life mentioned above.

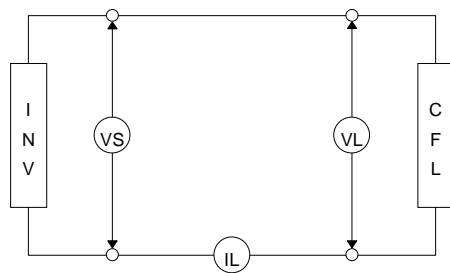

CFL Testing Circuit

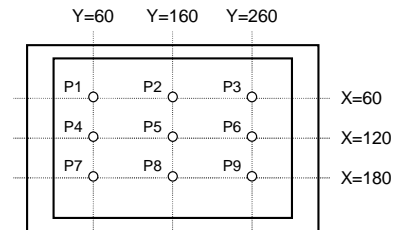

Measurement Points

3. Optical Specifications

3.1. Optical Characteristics

Ta=25°C, 1/240 Duty, 1/16 Bias, V_{OD}=24.5V, θ = 0°, φ = -°

Parameter		Symbol	Conditions	Min.	Typ.	Max.	Units
Contrast Ratio	Note 1	CR	θ = 0°, φ = -°	—	20	—	
Chromaticity (white)		x	—	—	0.324	—	
		y	—	—	0.361	—	
Viewing Angle			Shown in 3.3				
Response Time	Rise Note 2	T _{ON}	—	—	540	810	ms
	Decay Note 3	T _{OFF}	—	—	160	240	ms

Note 1 : Contrast ratio is defined as follows.

$$CR = L_{ON} / L_{OFF}$$

L_{ON} : Luminance of the ON segments

L_{OFF} : Luminance of the OFF segments

Note 2 : The time that the luminance level reaches 90% of the saturation level from 0% when ON signal is applied.

Note 3 : The time that the luminance level reaches 10% of the saturation level from 100% when OFF signal is applied.

Note 4 : Definition of Driving Voltage V_{OD}

$$V_{OD} = V_{CC1} - V_{ADJ} - V_{BE}$$

Assuming that the typical driving waveforms shown below are applied to the LCD Panel at 1/A Duty - 1/B Bias (A : Duty Number, B : Bias Number). Driving voltage V_{OD} is defined as the voltage V_{O-P} when the contrast ratio (CR=L_{ON} / L_{OFF}) is at its maximum.

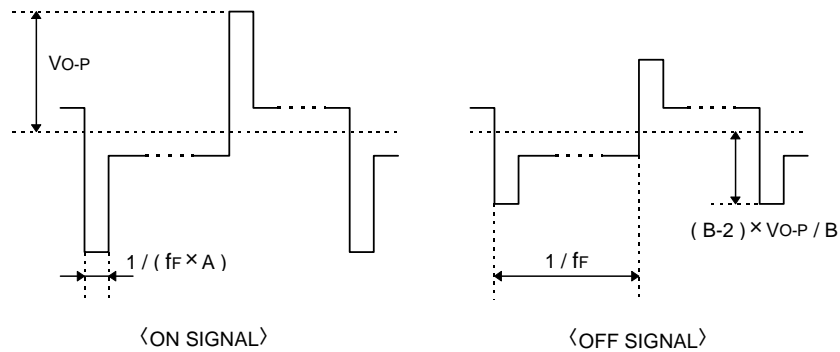

3.2. Definition of Viewing Angle and Optimum Viewing Area

- Point ● shows the point where contrast ratio is measured. : $\theta = 0^\circ$, $\phi = -^\circ$
- Driving condition : 1/240 Duty, 1/16 Bias, $V_{OD} = 24.5V$ (Shown in 3.1 Note4), $f_F = 70Hz$

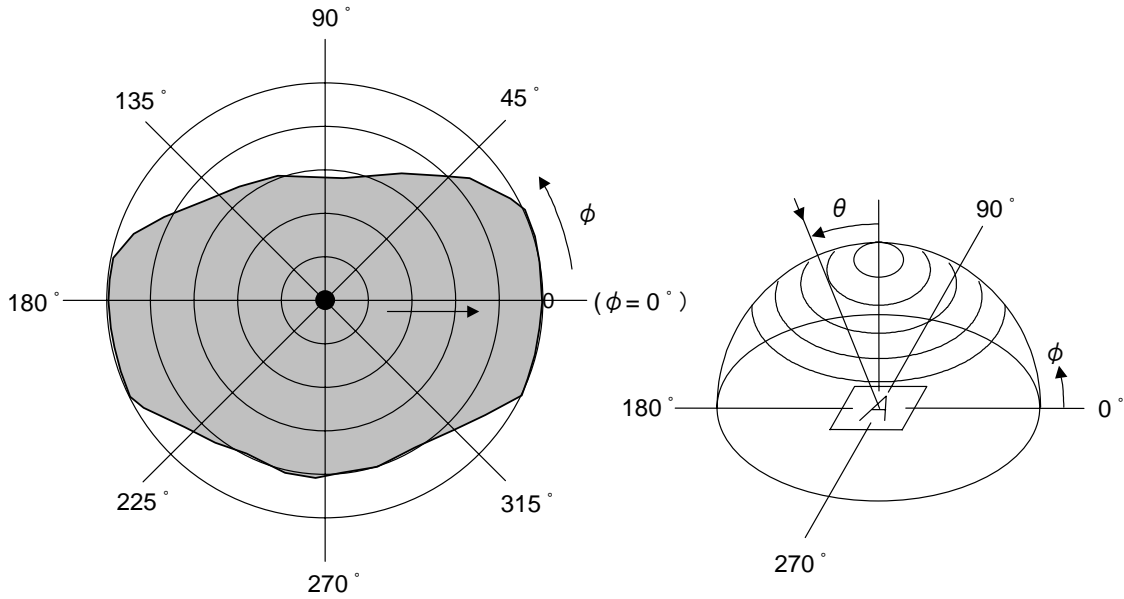

• Area  shows typ. $CR \geq 2$

3.3. System Block Diagram

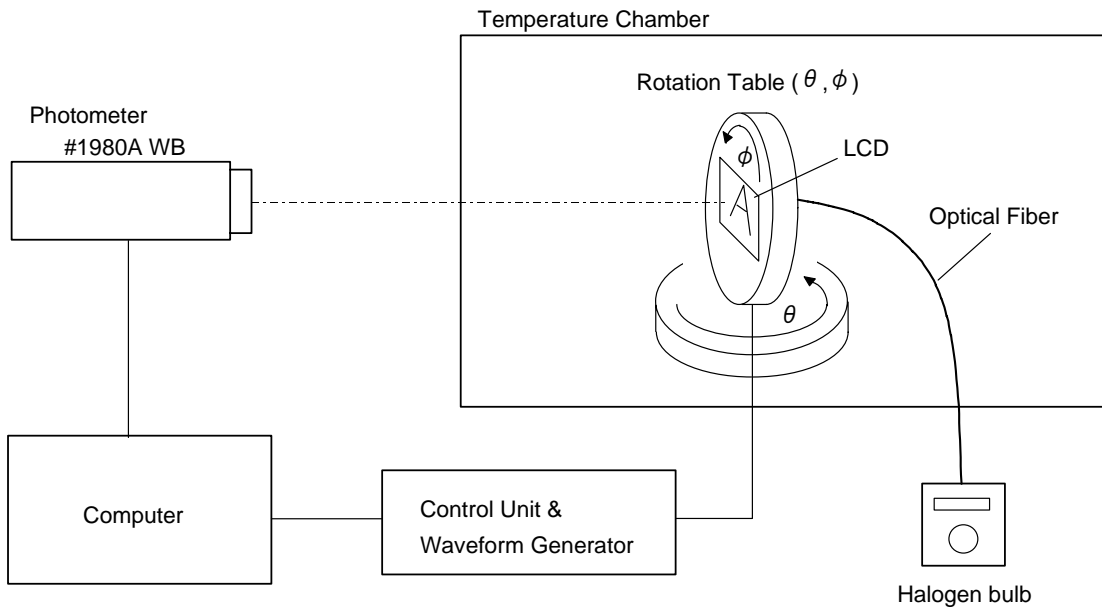

4. I/O Terminal

4.1. Pin Assignment

CN1

No.	Symbol	Level	Function
1	D0	H / L	Display Data
2	D1	H / L	Display Data
3	D2	H / L	Display Data
4	D3	H / L	Display Data
5	D4	H / L	Display Data
6	D5	H / L	Display Data
7	D6	H / L	Display Data
8	D7	H / L	Display Data
9	$\overline{\text{DISP OFF}}$	H / L	Display Control Signal H : Display on L : Display off
10	FLM	H / L	First Line Marker
11	LP	H→L	Data Latch Signal
12	CP	H→L	Clock Signal for Shifting Data
13	M	H / L	Alternate Signal for LCD Drive
14	VCC1	—	Power Supply for Logic
15	VSS	—	Power Supply (0V, GND)
16	VSS	—	Power Supply (0V, GND)
17	VCC2	—	Power Supply for LCD Drive
18	V _{ADJ}	—	Voltage Level for LCD Contrast Adjustment

CN2

No.	Symbol	Level	Function
1	HOT	—	Power Supply for CFL (HOT)
2	NC	—	Non-connection
3	NC	—	Non-connection
4	LGND	—	Power Supply for CFL (GND)

4.2. Example of Power Supply

It is recommended to apply a potentiometer for the contrast adjust due to the tolerance of the driving voltage and its temperature dependence.

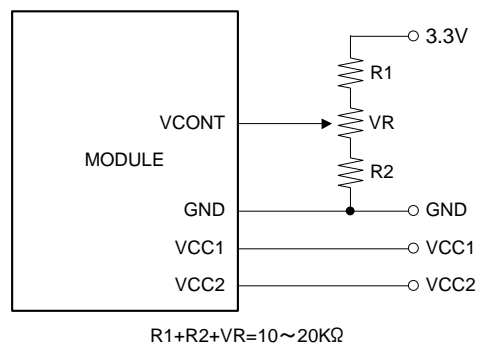

4.3. Block Diagram

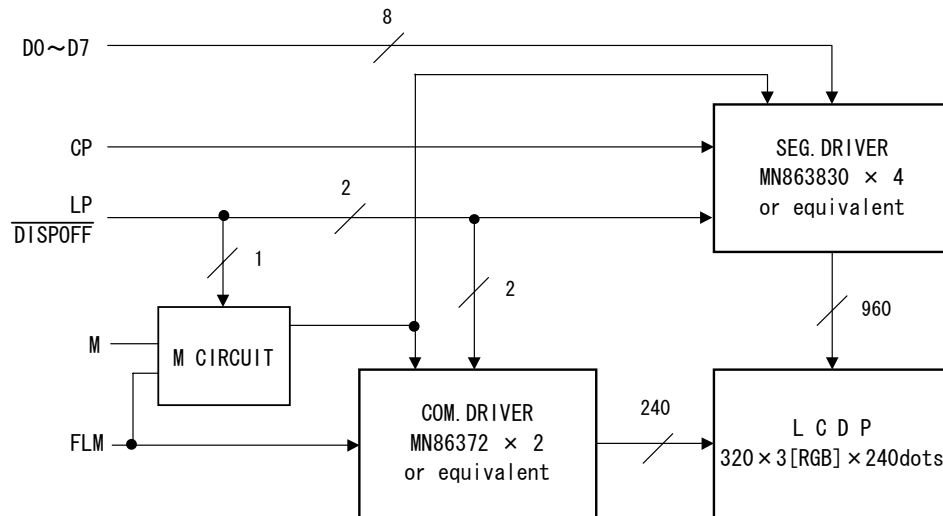

VCC1 —————> TO LSI LOGIC

VCC2 ———> DC/DC Converter+ Bias circuit ———> TO LSI
 VADJ ———>

VSS ———> 

HOT ———> CFL ———> LGND

5. Test

No change on display and in operation under the following test condition.

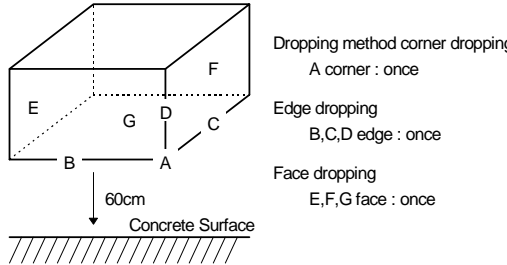
No.	Parameter	Conditions	Notes
1	High Temperature Operating	50°C ± 2°C, 96hrs (operation state)	
2	Low Temperature Operating	0°C ± 2°C, 96hrs (operation state)	3
3	High Temperature Storage	70°C ± 2°C, 96hrs	4
4	Low Temperature Storage	-20°C ± 2°C, 96hrs	3, 4
5	Damp Proof Test	40°C ± 2°C, 90~95%RH, 96hrs	3, 4
6	Vibration Test	Total fixed amplitude : 1.5mm Vibration Frequency : 10~55Hz One cycle 60 seconds to 3 directions of X, Y, Z for each 15 minutes	5
7	Shock Test	To be measured after dropping from 60cm high on the concrete surface in packing state. 	

Note 1 : Unless otherwise specified, tests will be conducted under the following condition.

Temperature : 20 ± 5°C

Humidity : 65 ± 5%

Note 2 : Unless otherwise specified, tests will be not conducted under functioning state.

Note 3 : No dew condensation to be observed.

Note 4 : The function test shall be conducted after 4 hours storage at the normal temperature and humidity after removed from the test chamber.

Note 5 : Vibration test will be conducted to the product itself without putting it in a container.

6. Appearance Standards

6.1. Inspection conditions

The LCD shall be inspected under 40W white fluorescent light.

The distance between the eyes and the sample shall be more than 30cm.

All directions for inspecting the sample should be within 45° against perpendicular line.

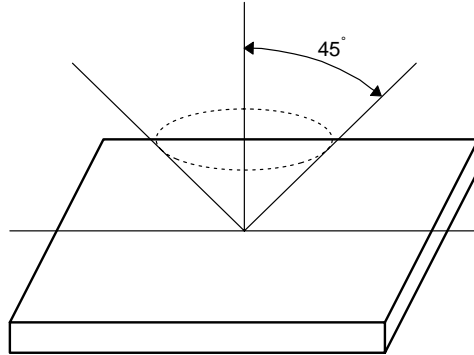

6.2. Definition of applicable Zones

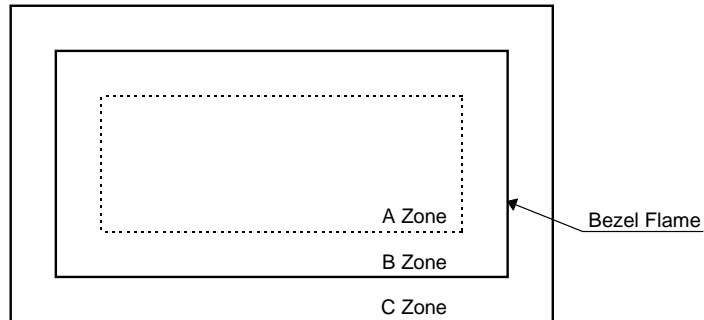

A Zone : Active display area

B Zone : Area from outside of "A Zone" to validity viewing area

C Zone : Rest parts

A Zone + B Zone = Validity viewing area

6.3. Standards

No.	Parameter	Criteria																												
1	Black and White Spots, Foreign Substances	(1) Round Shape <table border="1" style="margin-left: 20px;"> <thead> <tr> <th style="text-align: center;">Zone</th> <th colspan="3" style="text-align: center;">Acceptable Number</th> </tr> <tr> <th style="text-align: center;">Dimension (mm)</th> <th style="text-align: center;">A</th> <th style="text-align: center;">B</th> <th style="text-align: center;">C</th> </tr> </thead> <tbody> <tr> <td style="text-align: center;">$D \leq 0.1$</td> <td style="text-align: center;">*</td> <td style="text-align: center;">*</td> <td style="text-align: center;">*</td> </tr> <tr> <td style="text-align: center;">$0.1 < D \leq 0.2$</td> <td style="text-align: center;">3</td> <td style="text-align: center;">5</td> <td style="text-align: center;">*</td> </tr> <tr> <td style="text-align: center;">$0.2 < D \leq 0.25$</td> <td style="text-align: center;">2</td> <td style="text-align: center;">3</td> <td style="text-align: center;">*</td> </tr> <tr> <td style="text-align: center;">$0.25 < D \leq 0.3$</td> <td style="text-align: center;">0</td> <td style="text-align: center;">1</td> <td style="text-align: center;">*</td> </tr> <tr> <td style="text-align: center;">$0.3 < D$</td> <td style="text-align: center;">0</td> <td style="text-align: center;">0</td> <td style="text-align: center;">*</td> </tr> </tbody> </table> <p style="margin-left: 20px;">$D = (\text{Long} + \text{Short}) / 2$ * : Disregard</p>	Zone	Acceptable Number			Dimension (mm)	A	B	C	$D \leq 0.1$	*	*	*	$0.1 < D \leq 0.2$	3	5	*	$0.2 < D \leq 0.25$	2	3	*	$0.25 < D \leq 0.3$	0	1	*	$0.3 < D$	0	0	*
		Zone	Acceptable Number																											
Dimension (mm)	A	B	C																											
$D \leq 0.1$	*	*	*																											
$0.1 < D \leq 0.2$	3	5	*																											
$0.2 < D \leq 0.25$	2	3	*																											
$0.25 < D \leq 0.3$	0	1	*																											
$0.3 < D$	0	0	*																											
(2) Line Shape <table border="1" style="margin-left: 20px;"> <thead> <tr> <th colspan="2" style="text-align: center;">Zone</th> <th colspan="3" style="text-align: center;">Acceptable Number</th> </tr> <tr> <th style="text-align: center;">X (mm)</th> <th style="text-align: center;">Y (mm)</th> <th style="text-align: center;">A</th> <th style="text-align: center;">B</th> <th style="text-align: center;">C</th> </tr> </thead> <tbody> <tr> <td style="text-align: center;">—</td> <td style="text-align: center;">$0.03 \geq W$</td> <td style="text-align: center;">*</td> <td style="text-align: center;">*</td> <td style="text-align: center;">*</td> </tr> <tr> <td style="text-align: center;">$2.0 \geq L$</td> <td style="text-align: center;">$0.05 \geq W$</td> <td style="text-align: center;">3</td> <td style="text-align: center;">3</td> <td style="text-align: center;">*</td> </tr> <tr> <td style="text-align: center;">$1.0 \geq L$</td> <td style="text-align: center;">$0.1 \geq W$</td> <td style="text-align: center;">3</td> <td style="text-align: center;">3</td> <td style="text-align: center;">*</td> </tr> <tr> <td style="text-align: center;">—</td> <td style="text-align: center;">$0.1 < W$</td> <td colspan="3" style="text-align: center;">In the same way (1)</td> </tr> </tbody> </table> <p style="margin-left: 20px;">X : Length Y : Width * : Disregard</p> <p>Total defects shall not exceed 5.</p>	Zone		Acceptable Number			X (mm)	Y (mm)	A	B	C	—	$0.03 \geq W$	*	*	*	$2.0 \geq L$	$0.05 \geq W$	3	3	*	$1.0 \geq L$	$0.1 \geq W$	3	3	*	—	$0.1 < W$	In the same way (1)		
Zone		Acceptable Number																												
X (mm)	Y (mm)	A	B	C																										
—	$0.03 \geq W$	*	*	*																										
$2.0 \geq L$	$0.05 \geq W$	3	3	*																										
$1.0 \geq L$	$0.1 \geq W$	3	3	*																										
—	$0.1 < W$	In the same way (1)																												
2	Air Bubbles (between glass & polarizer)	<table border="1" style="margin-left: 20px;"> <thead> <tr> <th style="text-align: center;">Zone</th> <th colspan="3" style="text-align: center;">Acceptable Number</th> </tr> <tr> <th style="text-align: center;">Dimension (mm)</th> <th style="text-align: center;">A</th> <th style="text-align: center;">B</th> <th style="text-align: center;">C</th> </tr> </thead> <tbody> <tr> <td style="text-align: center;">$D \leq 0.3$</td> <td style="text-align: center;">*</td> <td style="text-align: center;">*</td> <td style="text-align: center;">*</td> </tr> <tr> <td style="text-align: center;">$0.3 < D \leq 0.4$</td> <td style="text-align: center;">3</td> <td style="text-align: center;">*</td> <td style="text-align: center;">*</td> </tr> <tr> <td style="text-align: center;">$0.4 < D \leq 0.6$</td> <td style="text-align: center;">2</td> <td style="text-align: center;">3</td> <td style="text-align: center;">*</td> </tr> <tr> <td style="text-align: center;">$0.6 < D$</td> <td style="text-align: center;">0</td> <td style="text-align: center;">0</td> <td style="text-align: center;">*</td> </tr> </tbody> </table> <p style="margin-left: 20px;">* : Disregard</p> <p>Total defects shall not exceed 3.</p>	Zone	Acceptable Number			Dimension (mm)	A	B	C	$D \leq 0.3$	*	*	*	$0.3 < D \leq 0.4$	3	*	*	$0.4 < D \leq 0.6$	2	3	*	$0.6 < D$	0	0	*				
Zone	Acceptable Number																													
Dimension (mm)	A	B	C																											
$D \leq 0.3$	*	*	*																											
$0.3 < D \leq 0.4$	3	*	*																											
$0.4 < D \leq 0.6$	2	3	*																											
$0.6 < D$	0	0	*																											
3	The Shape of Dot	However, each pixel shall remain more than one-third of the original pixel size.																												
4	Polarizer Scratches	Not to be conspicuous defects.																												
5	Polarizer Dirts	If the stains are removed easily from LCDP surface, the module is not defective.																												
6	Complex Foreign Substance Defects	Black spots, line shaped foreign substances or air bubbles between glass & polarizer should be 5pcs maximum in total.																												
7	Distance between Different Foreign Substance Defects	$D \leq 0.2$: 20mm or more $0.2 < D$: 40mm or more																												

7. Code System of Production Lot

The production lot of module is specified as follows.

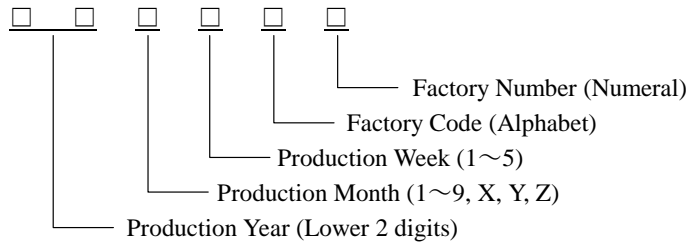

8. Type Number

The type number of module is specified on the back of module as follows.

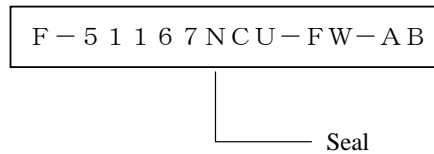

9. Applying Precautions

Please contact us when questions and/or new problems not specified in this specifications arise.

10. Precautions Relating Product Handling

The Following precautions will guide you in handling our product correctly.

1) Liquid crystal display devices

- ① The liquid crystal display device panel used in the liquid crystal display module is made of plate glass. Avoid any strong mechanical shock. Should the glass break handle it with care.
- ② The polarizer adhering to the surface of the LCD is made of a soft material. Guard against scratching it.

2) Care of the liquid crystal display module against static electricity discharge.

- ① When working with the module, be sure to ground your body and any electrical equipment you may be using. We strongly recommend the use of anti static mats (made of rubber), to protect work tables against the hazards of electrical shock.
- ② Avoid the use of work clothing made of synthetic fibers. We recommend cotton clothing or other conductivity-treated fibers.
- ③ Slowly and carefully remove the protective film from the LCD module, since this operation can generate static electricity.

3) When the LCD module alone must be stored for long periods of time:

- ① Protect the modules from high temperature and humidity.
- ② Keep the modules out of direct sunlight or direct exposure to ultraviolet rays.
- ③ Protect the modules from excessive external forces.

4) Use the module with a power supply that is equipped with an overcurrent protector circuit, since the module is not provided with this protective feature.

5) Do not ingest the LCD fluid itself should it leak out of a damaged LCD module. Should hands or clothing come in contact with LCD fluid, wash immediately with soap.

6) Conductivity is not guaranteed for models that use metal holders where solder connections between the metal holder and the PCB are not used. Please contact us to discuss appropriate ways to assure conductivity.

7) For models which use CFL:

- ① High voltage of 1000V or greater is applied to the CFL cable connector area. Care should be taken not to touch connection areas to avoid burns.
- ② Protect CFL cables from rubbing against the unit and thus causing the wire jacket to become worn.
- ③ The use of CFLs for extended periods of time at low temperatures will significantly shorten their service life.

8) For models which use touch panels:

- ① Do not stack up modules since they can be damaged by components on neighboring modules.
- ② Do not place heavy objects on top of the product. This could cause glass breakage.

9) For models which use COG, TAB, or COF:

- ① The mechanical strength of the product is low since the IC chip faces out unprotected from the rear. Be sure to protect the rear of the IC chip from external forces.
- ② Given the fact that the rear of the IC chip is left exposed, in order to protect the unit from electrical damage, avoid installation configurations in which the rear of the IC chip runs the risk of making any electrical contact.

10) Models which use flexible cable, heat seal, or TAB:

- ① In order to maintain reliability, do not touch or hold by the connector area.
- ② Avoid any bending, pulling, or other excessive force, which can result in broken connections.

11. Warranty

This product has been manufactured to your company's specifications as a part for use in your company's general electronic products. It is guaranteed to perform according to delivery specifications. For any other use apart from general electronic equipment, we cannot take responsibility if the product is used in medical devices, nuclear power control equipment, aerospace equipment, fire and security systems, or any other applications in which there is a direct risk to human life and where extremely high levels of reliability are required. If the product is to be used in any of the above applications, we will need to enter into a separate product liability agreement.

- ① We cannot accept responsibility for any defect, which may arise from additional manufacturing of the product (including disassembly and reassembly), after product delivery.
- ② We cannot accept responsibility for any defect, which may arise after the application of strong external force to the product.
- ③ We cannot accept responsibility for any defect, which may arise due to the application of static electricity after the product has passed your company's acceptance inspection procedures.
- ④ When the product is in CFL models, CFL service life and brightness will vary according to the performance of the inverter used, leaks, etc. We cannot accept responsibility for product performance, reliability, or defect, which may arise.
- ⑤ We cannot accept responsibility for industrial property, which may arise through the use of your product, with exception to those issues relating directly to the structure or method of manufacturing of our product.
- ⑥ Optrex will not be held responsible for any quality guarantee issue for defect products judged as Optrex-origin longer than 2 (two) years from Optrex production or 1 (one) year from Optrex, Optrex America, Optrex Europe, Display LC delivery whichever ever comes later.