

## User's Guide

NHD-1.8-128160YF-CTXI#

# TFT

(Liquid Crystal Display Graphic Module)

1.8" Diagonal  
8/16 - bit interface  
128x160 Resolution (portrait mode)  
White LED Backlight

---

Tel: (847) 844-8795 Fax: (847) 844-8796

**Newhaven Display International**  
**2511 Technology Drive, #101**  
**Elgin, IL 60124**

*March 30, 2009*

---

---

## RECORDS OF REVISION

DATE	REVISED NO.	REVISED DESCRIPTIONS	PREPARED	CHECKED	APPROVED
Oct-17-2007	1.00	FIRST ISSUE			

---

---

## CONTENTS

1.	FEATURES- -----	1
2.	BLOCK DIAGRAM &APPLICATION CIRCUIT -----	1
3.	OUTLINE DIMENSIONS- -----	2
4.	INTERFACE PIN CONNECTIONS-----	4
5.	ELECTRICAL CHARACTERISTICS -----	4
6.	Electro-Optical Characteristics -----	5
7.	QUALITY GUARANTEE & INSPECTION CRITERIA ---	8
8.	RELIABILITY -----	11

## 1. FEATURES

ITEM	STANDARD VALUE	UNIT
LCD Type	1.77" TFT-LCD (Thin Film Transistor Liquid Crystal Display)	---
Viewing Direction	6:00	O'clock
Backlight Type	2-Parallel-White LED	---
Module Outsize	34.0*47.0*2.4	mm
TP Viewing area	/	mm
TP Active area	/	mm
LCD Active area	28.032*35.04	mm
Dot Number	128(RGB) × 160	---
Dot size	0.219*0.219	mm
Operation temperature	-10 ~70	°C
Storage temperature	-30 ~80	°C
Driver IC	S6D0144	---
Interface mode	8080 System 8/16 bit Interface	---

Remark:

1. Display color support 262K/65K, In detail please see also the S6D0144 specification.

## 2. BLOCK DIAGRAM

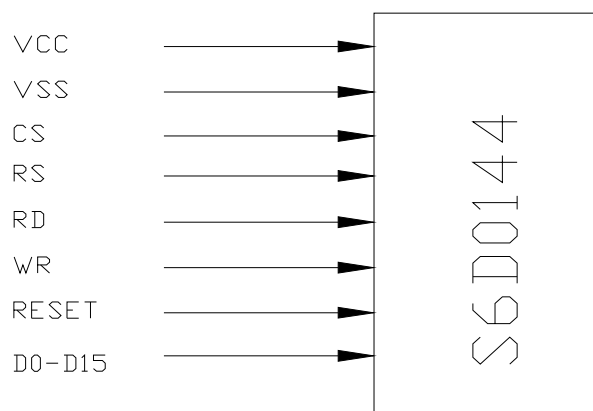

### 3. OUTLINE DIMENSIONS

REV	EC NUMBER	DESCRIPTION	DATE
①	XXXXXX	XXXXXXXXXX	xxxx/xx/xx

PIN DESCRIPTION	
1	LED-A1
2	LED-A2
3	LED-K
4	IM0
5	RESETB
6	DB15
7	DB14
8	DB13
9	DB12
10	DB11
11	DB10
12	DB9
13	DB8
14	DB7
15	DB6
16	DB5
17	DB4
18	DB3
19	DB2
20	DB1
21	DB0
22	RD
23	WR
24	RS
25	CS
26	NC
27	VCC
28	GND
29	TP
30	TP
31	TP
32	TP
33	GND

NOTES:

- 1.DISPLAY TYPE: TFT-LCD
- 2.1.BLICKLIGHT 2 CHIP LEDs,parallel connection
- 3.OPERATING TEMP: -20°~70°
- 4.STORAGE TEMP: -30°~80°
- 5.DRIVER IC: S6D0144
- 6.GENERAL TOLERANCE:±0.2
7. ROHS

	DRAWN	ME CHECKED	EE CHECKED	APPROVED
PAGE:1/1	VER. A	SCALE:1/1		
TOLERANCE UNLESS:±0.3				

#### 4. NTERFACE PIN CONNECTIONS

PIN	SYMBOL	FUNCTION
1	LED-A1	Anode of backlight
2	LED-A2	
3	LED-K	Cathode of backlight
4	IMO	Select the MPU system interface mode
5	RESET	Reset Signal
6	DB15	16-bit data bus
7	DB14	
8	DB13	
9	DB12	
10	DB11	
11	DB10	
12	DB9	
13	DB8	
14	DB7	
15	DB6	
16	DB5	
17	DB4	
18	DB3	
19	DB2	
20	DB1	
21	DB0	
22	RD	Read signal pin
23	WR	Write signal pin
24	RS	Data/Common select
25	CS	Chip select
26	NC	NO connect
27	VCC	Power supply
28	GND	Ground
29	TP PIN	TP pin
30	TP PIN	
31	TP PIN	
32	TP PIN	
33	GND	Ground

IMO	MPU-Interface Mode	DB Pin in use
GND	i80-system 16-bit interface	DB[15:0]
VCC	i80-system 8-bit interface	DB[15:8]

---

## 5. ELECTRICAL CHARACTERISTICS

### 5.1 ABSOLUTE MAXIMUM RATING

(VSS = 0V)

Item	Symbol	Rating	Unit
Supply voltage for logic block	VDD - VSS	-0.3 ~ 3.3	V
Supply voltage for I/O block	VDD3 - VSS	-0.3 ~ 5.0	
Supply voltage for step-up circuit	VCI - VSS	-0.3 ~ 5.0	V
LCD Supply Voltage range	AVDD - VSS	-0.3 ~ 6.5	V
	VGH - VSS	-0.3 ~ 22.0	
	VSS - VGL	-0.3 ~ 22.0	
	VSS - VCL	-0.3 ~ 5.0	
	VGH - VGL	-0.3 ~ 33	
Input Voltage range	Vin	- 0.3 to VDD3 +0.3	V

### 5.2 DC Characteristics

Characteristic	Symbol	CONDITION	MIN	TYP	MAX	Unit
Operating voltage	VDD		1.40		1.60	V
	VDD3		1.65		3.3	V
LCD driving voltage	VGH		+7		16.5	V
	VGL		-13.5		-7	V
	AVDD		3.5		5.5	V
Input high voltage	V <sub>IH</sub>		0.8VDD3		VDD3	V
Input low voltage	V <sub>IL</sub>		0		0.2VDD3	V
Output high voltage	V <sub>OH</sub>	I <sub>OH</sub> = -1.0mA	0.8VDD3		VDD3	V
Output low voltage	V <sub>OL</sub>	I <sub>OL</sub> = 10mA	0.0		0.2VDD3	V

### 5.3 AC Characteristics

*Please Refer to the SPEC of S6D0144 .*

## 6. Electro-Optical Characteristics

### 6.1 Backlight Unit

Item	Symbol	Min	Typ.	Max	Unit	Remark
Input voltage	V <sub>BL</sub>		3.2		V	-
Current	I <sub>BL</sub>	---	18	---	mA	-
ICE	X	0.26	-	0.30	-	X>Y
	Y	0.27	-	0.31	-	
Brightness	-	---	2800	---	cd/m <sup>2</sup>	
Luminous Intensity Ratio	-	---	----	20	%	-

### 6.2 LCD panel

Item	Symbol	Conditions	Specifications			Unit	Note	
			Min.	Typ.	Max.			
Transmittance	T%	Viewing normal angle $\theta_x = \theta_y = 0^\circ$		6.5		%	All left side data are based on CMO's following condition -- Type 6 NTSC: 58% LC: 5066 Light : C light (Machine:BM5A) Polarizer without DBEF <b>Reference Only</b>	
Contrast Ratio	CR		150	250	-	--		
Response Time	T <sub>R</sub>		-	10	20	ms		
	T <sub>F</sub>		-	20	30	ms		
Chromaticity	Red		X <sub>R</sub>	0.611	0.641	0.671		
			Y <sub>R</sub>	0.315	0.345	0.375		
	Green		X <sub>G</sub>	0.266	0.296	0.326		
			Y <sub>G</sub>	0.554	0.584	0.614		
	Blue		X <sub>B</sub>	0.102	0.132	0.162		
			Y <sub>B</sub>	0.106	0.136	0.166		
White	X <sub>W</sub>	0.279	0.309	0.339				
	Y <sub>W</sub>	0.318	0.348	0.378				
Viewing Angle	Hor.	$\theta_{x+}$	-	45		deg.		
		$\theta_{x-}$	-	45				
	Ver.	$\theta_{y+}$	-	35				
		$\theta_{y-}$	-	15				



**\*Note (1) Definition of Contrast Ratio (CR):**

The contrast ratio can be calculated by the following expression.

$$\text{Contrast Ratio (CR)} = L_{63} / L_0$$

L63: Luminance of gray level 63

L0: Luminance of gray level 0

$$\text{CR} = \text{CR} (10)$$

CR (X) is corresponding to the Contrast Ratio of the point X at Figure in Note (6).

**\*Note (2) Definition of Response Time (TR, TF):**

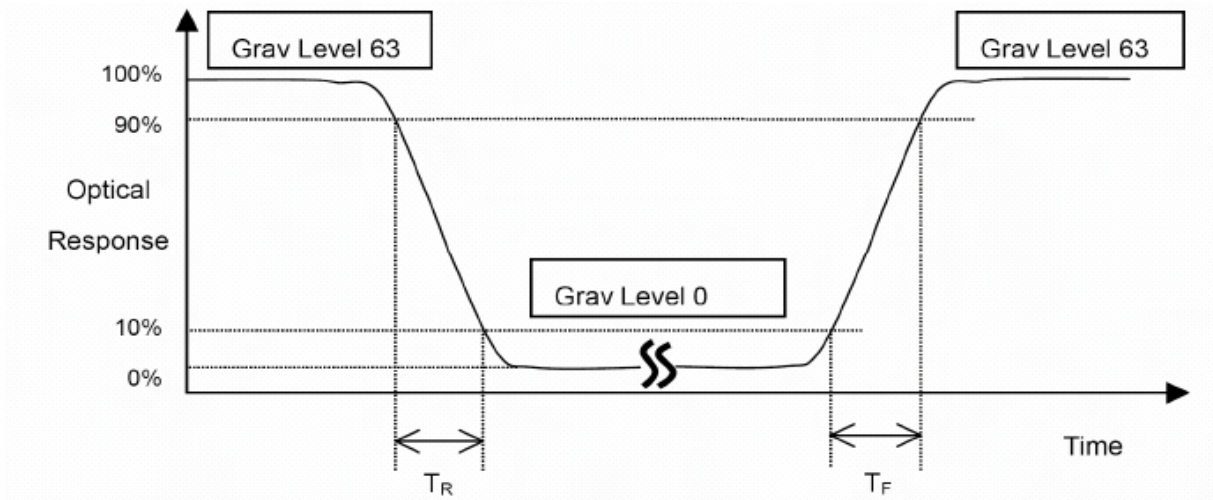

**\*Note(3) Definition of Viewing Angle**

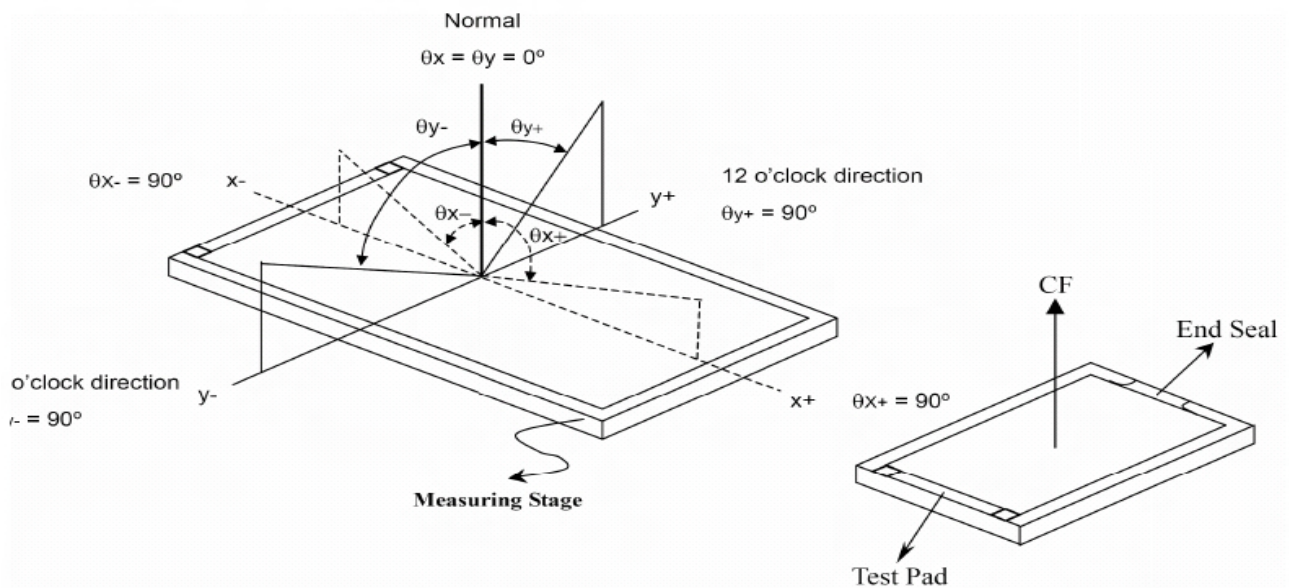

**\*Note (4) Measurement Set-Up:**

The LCD module should be stabilized at a given temperature for 20 minutes to avoid abrupt temperature change during measuring. In order to stabilize the luminance, the measurement should be executed after lighting Backlight for 20 minutes in a windless room.

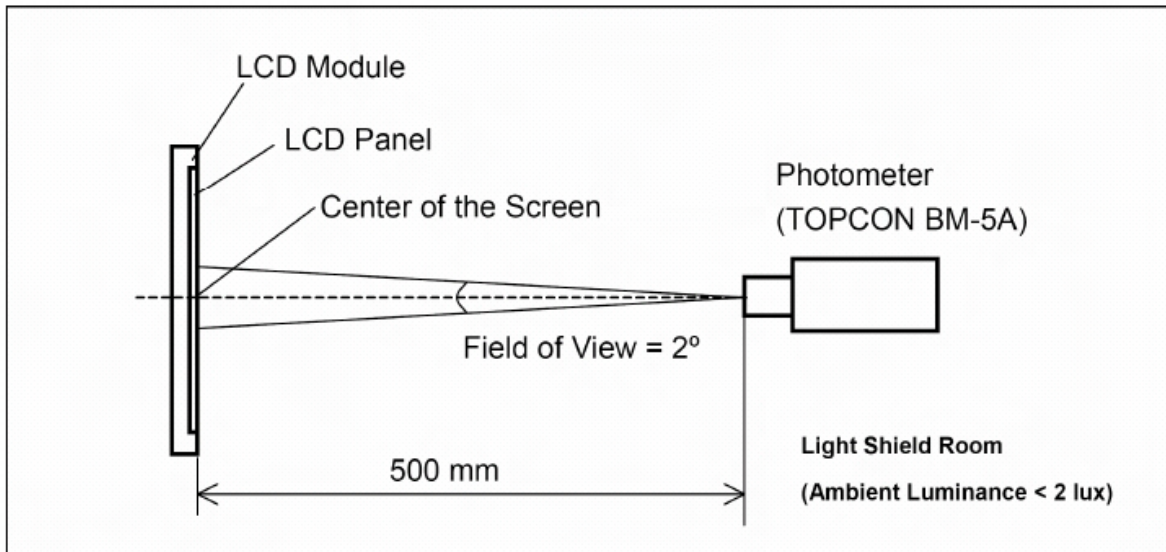

**\*Note (5)**

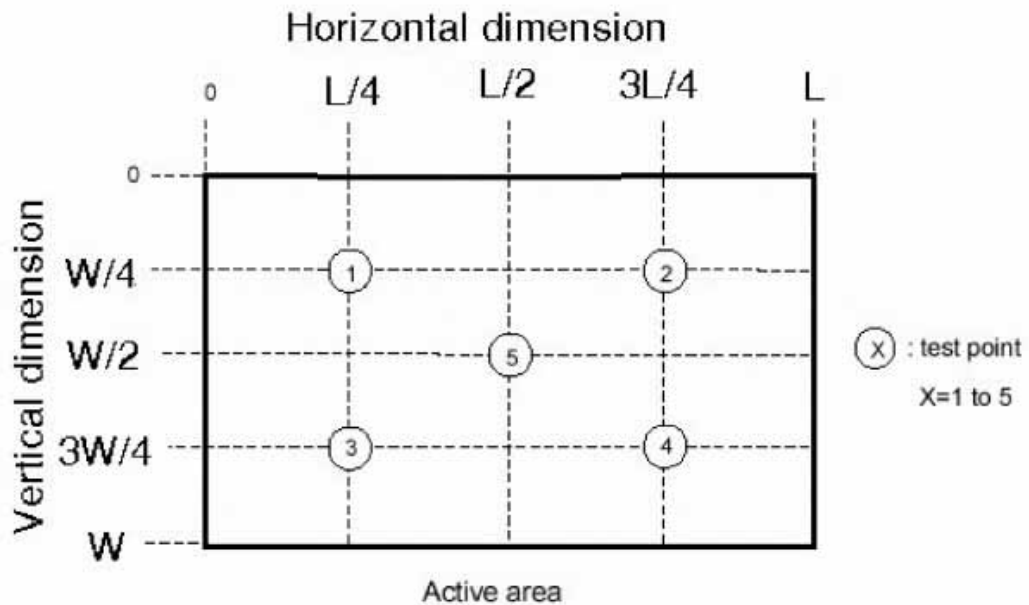

---

## 7. QUALITY GUARANTEE & INSPECTION CRITERIA

### 7.1 Appearance inspection

Appearance inspection should be done under the following condition.

- (1) In the dark room.
- (2) The distance from eyes to LCD must be 30 cm.
- (3) Viewing direction must be within 30 degrees to vertical line of LCD center.

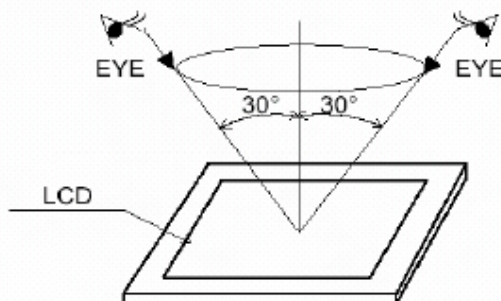

### 7.2 Definition of A zone, B zone and C zone

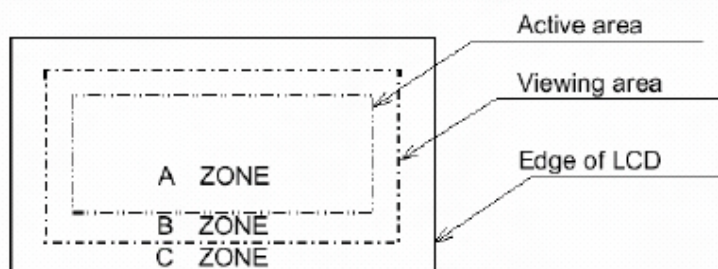

### 7.3 Electrical Testing

1. Missing vertical, horizontal segment, segment contrast defect.
2. Missing character, dot or icon.
3. Display malfunction.
4. No function or no display.
5. Current consumption exceeds product specifications.
6. LCD viewing angle defect.
7. Mixed product types.
8. Contrast defect

#### 7.4 Black or white spots on LCD (display only)

1. White and black spots on display  $\leq 0.20\text{mm}$ , no more than three white or black spots present.
2. Densely spaced: No more than two spots or lines within 5mm

#### 7.5 LCD black spots, white spots, contamination (non-display)

1. Round type: As following drawing

$$\psi = (x+y)/2$$

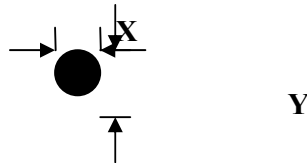

SIZE	Acceptable QTY
$\psi \leq 0.10$	Accept no dense
$0.10 < \psi \leq 0.15$	2
$0.15 < \psi \leq 0.20$	1
total	2

2. Line Type: (As following drawing)

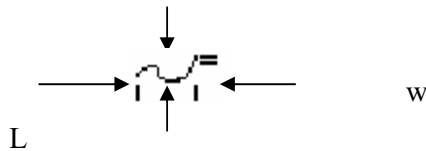

Length	Width	Acceptable QTY
---	$W \leq 0.02$	Accept no dense
$L \leq 3.0$	$0.02 < W \leq 0.03$	2
$L \leq 2.5$	$0.03 < W \leq 0.05$	
---	$0.05 < W$	As round type

#### 7.6 Polarizer bubbles

If bubbles are visible, judge using black spot specifications, not easy to find, must check in specify direction.

Size $\psi$	Acceptable QTY
$\psi \leq 0.20$	Accept no dense
$0.20 < \psi \leq 0.50$	2

---

## 7.7 Chipped glass

Symbols:

a: Chip length    b: Chip width    c: Chip thickness

t: Glass thickness

1 ITO electrode

$a \leq t$

$b \leq 0.5\text{mm}$

$c \leq 3.0\text{mm}$

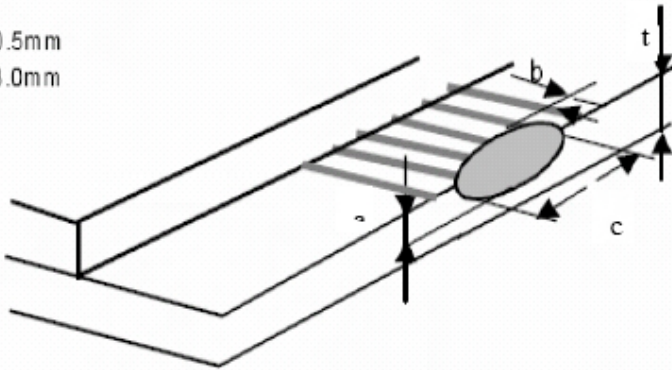

2 General ,corner portion

$a \leq t$

$b \leq 1.0\text{mm}$

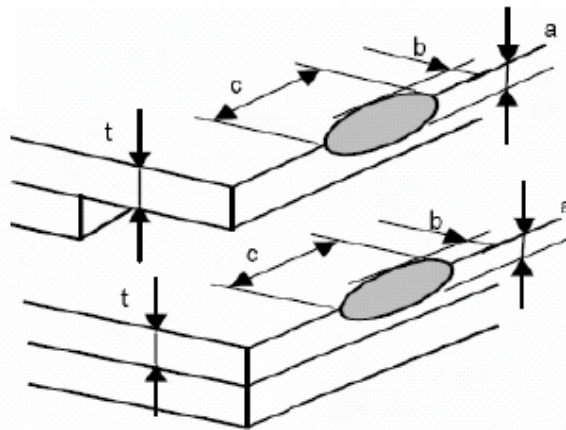

\*Effective width of seal area shall be more than 0.3mm.

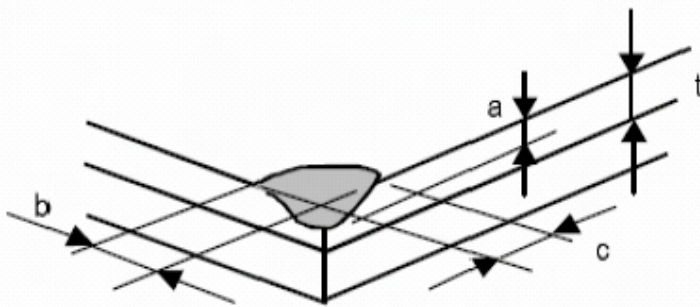



---

## **7.8 Backlight elements**

1. Illumination source flickers when lit.
2. Spots or scratches that appear when lit must be judged using LCD spot, lines and contamination standards.
3. Backlight doesn't light or color is wrong

## **7.9 Soldering**

1. No unmelted solder paste may be present on the PCB.
2. No cold solder joints, missing solder connections, oxidation or icicle.
3. No residue or solder balls on PCB.
4. No short circuits in components on PCB.

## **7.10 General appearance**

1. No oxidation, contamination, curves or, bends on interface pin (OLB) of TCP.
2. No cracks on interface pin (OLB) of TCP
3. NO contamination, solder residue or solder balls on product.
4. The IC on the TCP may not be damaged, circuits.
5. The uppermost edge of the protective strip on the interface pin must be present or look as if it cause the interface pin to sever.
6. The residual rosin or tin oil of soldering (component or chip component) is not burned into brown or black color.
7. Sealant on top of the ITO circuit has not hardened
8. Pin type must match type in specification sheet.
9. LCD pin loose or missing pins.
10. Product packaging must the same as specified on packaging specification sheet.
11. Product dimension and structure must conform to product specification sheet.
12. The appearance of Heat Seal should not admit any dirt and break.

## 8. RELIABILITY

Test Item	Sample Type	Test Condition	Test result determinant gist
High temperature storage	Normal temperature	$70 \pm 3^{\circ}\text{C}; 240\text{H}$	the inspection of Appearance and function character.
	Broad temperature	$80 \pm 3^{\circ}\text{C}; 240\text{H}$	
Low temperature storage	Normal temperature	$-20 \pm 3^{\circ}\text{C}; 240\text{H}$	
	Broad temperature	$-30 \pm 3^{\circ}\text{C}; 240\text{H}$	
High temperature /humidity storage	Normal temperature	$50^{\circ}\text{C} \pm 3^{\circ}\text{C}, 90\% \pm 3\%\text{RH}; 240\text{H}$	
	Broad temperature	$60^{\circ}\text{C} \pm 3^{\circ}\text{C}, 90\% \pm 3\%\text{RH}; 240\text{H}$	
High temperature operation	Normal temperature	$60 \pm 3^{\circ}\text{C}; 96\text{H}$	No objection of the function character; no fatal objection of the appearance.
	Broad temperature	$70 \pm 3^{\circ}\text{C}; 96\text{H}$	
Low temperature operation	Normal temperature	$0 \pm 3^{\circ}\text{C}; 96\text{H}$	
	Broad temperature	$-20 \pm 3^{\circ}\text{C}; 96\text{H}$	
High temperature /humidity operation	Normal temperature	$40^{\circ}\text{C} \pm 3^{\circ}\text{C}, 90\% \pm 3\%\text{RH}; 96\text{H}$	
	Broad temperature	$50^{\circ}\text{C} \pm 3^{\circ}\text{C}, 90\% \pm 3\%\text{RH}; 96\text{H}$	
Temperature Shock	Normal temperature	$-20 \pm 3^{\circ}\text{C}, 30\text{min} \rightarrow 70 \pm 3^{\circ}\text{C}, 30\text{min}; 10\text{cycle}$	inspect the objections appearance、function & the whole structure
	Broad temperature	$-30 \pm 3^{\circ}\text{C}, 30\text{min}$ $80 \pm 3, 30\text{min}; 10\text{cycle}$	The inspection of appearance、function & the whole structure

ESD test	ALL	Discharge modality: Air discharge. Discharge voltage: $\pm 2KV/\pm 4 KV/\pm 6K \pm 8KV/\pm 12KV/15KV$	.no software error & objection in $\pm 2KV\sim\pm 12KV$ ,no hardware errors & objection in $\pm 15KV$ .
		Discharge modality: Contact discharge Discharge voltage: $\pm 2KV/\pm 4 KV/\pm 6KV/\pm 8KV$	no software errors & objection in $\pm 2KV\sim\pm 12KV$ ,no hardware errors & objection in $\pm 8KV$ .
Bend test	ALL	Bend velocity: 60time/min; Bendtimes:50000tims	Stimulate the folder's repeat folding, no objection of display function
Vibration test	ALL	frequencyrange:10HZ~55HZ;swing:0.75mm;Z-axist direction: 60min.	the inspection of appearance、function & the whole structure

## 9. PRECAUTIONS FOR USING LCD MODULES

### Handing Precautions

(1) The display panel is made of glass. Do not subject it to a mechanical shock by dropping it or impact.

(2) If the display panel is damaged and the liquid crystal substance leaks out, be sure not to get any in your mouth. If the substance contacts your skin or clothes, wash it off using soap and water.

(3) Do not apply excessive force to the display surface or the adjoining areas since this may cause the color tone to vary.

(4) The polarizer covering the display surface of the LCD module is soft and easily scratched. Handle this polarizer carefully.

(5) If the display surface becomes contaminated, breathe on the surface and gently wipe it with a soft dry cloth. If it is heavily contaminated, moisten cloth with one of the following solvents :

- Isopropyl alcohol
- Ethyl alcohol

(6) Solvents other than those above-mentioned may damage the polarizer. Especially, do not use the following.

- Water



- 
- Ketone
  - Aromatic solvents

(7) Exercise care to minimize corrosion of the electrode. Corrosion of the electrodes is accelerated by water droplets, moisture condensation or a current flow in a high-humidity environment.

(8) Install the LCD Module by using the mounting holes. When mounting the LCD module make sure it is free of twisting, warping and distortion. In particular, do not forcibly pull or bend the IO cable or the backlight cable.

(9) Do not attempt to disassemble or process the LCD module.

(10) NC terminal should be open. Do not connect anything.

(11) If the logic circuit power is off, do not apply the input signals.

(12) To prevent destruction of the elements by static electricity, be careful to maintain an optimum work environment.

- Be sure to ground the body when handling the LCD modules.
- Tools required for assembling, such as soldering irons, must be properly grounded.
- To reduce the amount of static electricity generated, do not conduct assembling and other work under dry conditions.

- The LCD module is coated with a film to protect the display surface. Exercise care when peeling off this protective film since static electricity may be generated.

### **Storage Precautions**

When storing the LCD modules, avoid exposure to direct sunlight or to the light of fluorescent lamps. Keep the modules in bags (avoid high temperature, high humidity and low temperatures below 0 °C). Whenever possible, the LCD modules should be stored in the same conditions in which they were shipped from our company.

### **Others**

Liquid crystals solidify under low temperature (below the storage temperature range) leading to defective orientation or the generation of air bubbles (black or white). Air bubbles may also be generated if the module is subject to a low temperature.

If the LCD modules have been operating for a long time showing the same display patterns, the display patterns may remain on the screen as ghost images and a slight contrast irregularity may also appear. A normal operating status can be regained by suspending use for some time. It should be noted that this phenomenon does not adversely affect performance reliability.

To minimize the performance degradation of the LCD modules resulting from destruction caused by static electricity etc., exercise care to avoid holding the following sections when handling the modules.

- Exposed area of the printed circuit board.
- Terminal electrode sections.