

NHD-0440AZ-RN-FBW

Character Liquid Crystal Display Module

NHD-	Newhaven Display
0440-	4 lines x 40 characters
AZ-	Model
R-	Reflective
N-	No Backlight
F-	FSTN (+)
B-	6:00 view
W-	Wide Temp. (-20°C ~+70°C)
	RoHS Compliant

Newhaven Display International, Inc.

2511 Technology Drive, Suite 101

Elgin IL, 60124

Ph: 847-844-8795

Fax: 847-844-8796

www.newhavendisplay.com

nhtech@newhavendisplay.com

nhsales@newhavendisplay.com

Document Revision History

Revision	Date	Description	Changed by
0	10/21/2008	Initial Release	-
1	11/2/2009	User Guide Reformat	MC
2	11/16/2009	Updated Block diagram and initialization code	MC
3	1/5/2011	Updating driver information	JT

Functions and Features

- 4 lines x 40 characters

2 Built-in controllers (SPLC780D or ST7066U)

- +5.0V Power Supply
- 1/16 duty, 1/5 bias
- RoHS compliant

Mechanical Drawing

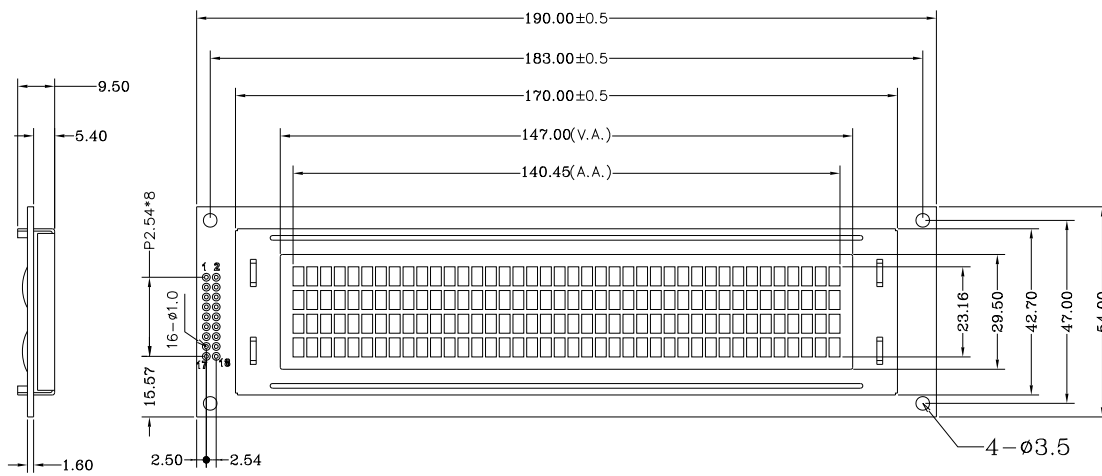

PIN ASSIGNMENT

1	DB7
2	DB6
3	DB5
4	DB4
5	DB3
6	DB2
7	DB1
8	DB0
9	E1
10	RW
11	RS
12	V0
13	VSS
14	VDD
15	E2
16	NC
17	NC
18	NC

Specification:

- 1) Driving: Duty:1/16, Bias:1/5, VLCD:4.5V, VDD:5.0V
- 2) Viewing Direction: 6 O'clock
- 3) Display mode: FSTN/Positive/Reflective
- 4) Operating temp.: -20°C ~ +70°C
Storage temp.: -30°C ~ +80°C
- 5) Driver: ST7066 or SPLC780D
- 6) RoHS Compliant

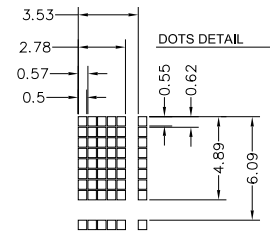

Newhaven Display

NHD-0440AZ-RN-FBW

Pin Description and Wiring Diagram

Pin No.	Symbol	External Connection	Function Description
1-4	DB7-DB4	MPU	Four high order bi-directional three-state data bus lines.
5-8	DB3-DB0	MPU	Four low order bi-directional three-state data bus lines. These four are not used during 4-bit operation.
9	E1	MPU	Operation enable signal. Falling edge triggered for top 2 lines.
10	R/W	MPU	Read/Write select signal, R/W=1: Read R/W:=0: Write
11	RS	MPU	Register select signal. RS=0: Command, RS=1: Data
12	V0	Power Supply	Power supply for contrast (approx. +0.5V)
13	Vss	Power Supply	Ground
14	VDD	Power Supply	Supply voltage for logic (+5.0V)
15	E2	MPU	Operation enable signal. Falling edge triggered for bottom 2 lines.
16	NC	-	No Connect
17	NC	-	No Connect
18	NC	-	No Connect

Recommended LCD connector: 2.54mm pitch pins

Backlight connector: --- **Mates with:** ---

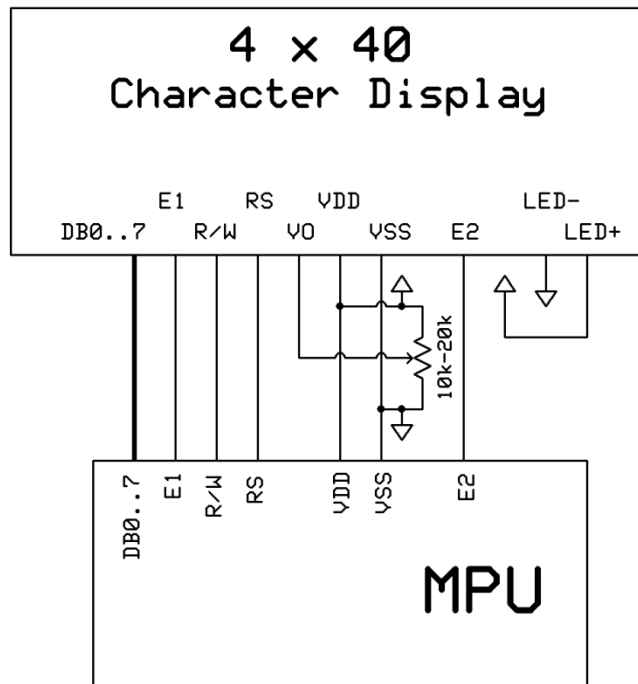

Electrical Characteristics

Item	Symbol	Condition	Min.	Typ.	Max.	Unit
Operating Temperature Range	Top	Absolute Max	-20	-	+70	°C
Storage Temperature Range	Tst	Absolute Max	-30	-	+80	°C
Supply Voltage	VDD		2.7	5.0	5.5	V
Supply Current	IDD	Ta=25°C, VDD=5.0V	-	3.5	4.0	mA
Supply for LCD (contrast)	VDD-V0	Ta=25°C	-	4.5	-	V
"H" Level input	Vih		2.2	-	VDD	V
"L" Level input	Vil		0	-	0.6	V
"H" Level output	Voh		2.4	-	-	V
"L" Level output	Vol		-	-	0.4	V
Backlight Supply Voltage	Vled	-	-	-	-	V
Backlight Supply Current	Iled	-	-	-	-	mA

Optical Characteristics

Item	Symbol	Condition	Min.	Typ.	Max.	Unit
Viewing Angle – Vertical (top)	AV	Cr ≥ 3	-	20	-	°
Viewing Angle – Vertical (bottom)	AV	Cr ≥ 3	-	50	-	°
Viewing Angle – Horizontal (left)	AH	Cr ≥ 3	-	30	-	°
Viewing Angle – Horizontal (right)	AH	Cr ≥ 3	-	30	-	°
Contrast Ratio	Cr		3	5	-	-
Response Time (rise)	Tr	-	-	150	250	ms
Response Time (fall)	Tf	-	-	150	250	ms

Controller Information

Built-in SPLC780D. Download specification at http://www.newhavendisplay.com/app_notes/SPLC780D.pdf

Built-in ST7066U. Download specification at http://www.newhavendisplay.com/app_notes/ST7066U.pdf

Display character address code

DDRAM address

															Display position				
1	2	3	4	5	-	-	-	-	-	-	-	-	-	-	36	37	38	39	40
00	01	02	03	04	-	-	-	-	-	-	-	-	-	-	23	24	25	26	27
40	41	42	43	44	-	-	-	-	-	-	-	-	-	-	63	64	65	66	67
00	01	02	03	04	-	-	-	-	-	-	-	-	-	-	23	24	25	26	27
40	41	42	43	44	-	-	-	-	-	-	-	-	-	-	63	64	65	66	67

DDRAM address

Built-in Font Table

Lower 4 Bits \ Upper 4 Bits	0000	0001	0010	0011	0100	0101	0110	0111	1000	1001	1010	1011	1100	1101	1110	1111
xxxx0000	CG RAM (1)			0	a	P	`	P				-	タ	ミ	&	P
xxxx0001	(2)		!	1	A	Q	a	q			。	ア	チ	△	ö	q
xxxx0010	(3)		"	2	B	R	b	r			「	イ	ツ	×	ß	θ
xxxx0011	(4)		#	3	C	S	c	s			」	ウ	テ	モ	ε	∞
xxxx0100	(5)		\$	4	D	T	d	t			、	エ	ト	ト	μ	Ω
xxxx0101	(6)		%	5	E	U	e	u			・	オ	ナ	1	ε	ü
xxxx0110	(7)		&	6	F	V	f	v			ヲ	カ	ニ	ヨ	ρ	Σ
xxxx0111	(8)		'	7	G	W	g	w			ア	キ	ヌ	ラ	g	π
xxxx1000	(1)		<	8	H	X	h	x			イ	ク	ネ	リ	√	∞
xxxx1001	(2)		>	9	I	Y	i	y			ウ	ケ	ル	ル	ˆ	γ
xxxx1010	(3)		*	:	J	Z	j	z			エ	コ	ハ	レ	j	≠
xxxx1011	(4)		+	;	K	[k	[オ	サ	ヒ	ロ	*	≠
xxxx1100	(5)		,	<	L	¥	l	l			カ	シ	フ	ク	φ	≠
xxxx1101	(6)		-	=	M]	m]			ユ	ス	ハ	ン	も	÷
xxxx1110	(7)		.	>	N	^	n	→			ヨ	セ	ホ	°	ñ	
xxxx1111	(8)		/	?	O	_	o	←			ッ	リ	マ	°	ö	■

Example Initialization Program

```
/******  
void command1(char i)           //Top half of the display  
{  
    P1 = i;  
    W = 0;  
    RS = 0;  
    E1 = 1;  
    delay(2);  
    E1 = 0;  
}  
void command2(char i)           //Bottom half of the display  
{  
    P1 = i;  
    W = 0;  
    RS = 0;  
    E2 = 1;  
    delay(2);  
    E2 = 0;  
}  
/******  
void writedata1(char i)         //Top half of the display  
{  
    P1 = i;  
    W = 0;  
    RS = 1;  
    E1 = 1;  
    delay(2);  
    E1 = 0;  
}  
void writedata2(char i)         //Bottom half of the display
```

```

{
    P1 = i;
    W = 0;
    RS = 1;
    E2 = 1;
    delay(2);
    E2 = 0;
}

/*****/

void init_LCD()
{
    delay(15);
    command1(0x30);    //Wake up
    command2(0x30);
    delay(5);
    command1(0x30);    //Wake up
    command2(0x30);
    delay(5);
    command1(0x30);    //Wake up
    command2(0x30);
    delay(5);
    command1(0x38);    //Function Set = 8bit mode; 2-line; 5x8
    command2(0x38);
    command1(0x08);    //Turn off display
    command2(0x08);
    command1(0x01);    //Clear display
    command2(0x01);
    command1(0x06);    //Entry mode cursor increment
    command2(0x06);
    command1(0x0c);    //Turn on display; no cursor
    command2(0x0c);
}

/*****/

```

Quality Information

Test Item	Content of Test	Test Condition	Note
High Temperature storage	Endurance test applying the high storage temperature for a long time.	+80°C , 48hrs	2
Low Temperature storage	Endurance test applying the low storage temperature for a long time.	-30°C , 48hrs	1,2
High Temperature Operation	Endurance test applying the electric stress (voltage & current) and the high thermal stress for a long time.	+70°C 48hrs	2
Low Temperature Operation	Endurance test applying the electric stress (voltage & current) and the low thermal stress for a long time.	-20°C , 48hrs	1,2
High Temperature / Humidity Operation	Endurance test applying the electric stress (voltage & current) and the high thermal with high humidity stress for a long time.	+40°C , 90% RH , 48hrs	1,2
Thermal Shock resistance	Endurance test applying the electric stress (voltage & current) during a cycle of low and high thermal stress.	0°C,30min -> 25°C,5min -> 50°C,30min = 1 cycle 10 cycles	
Vibration test	Endurance test applying vibration to simulate transportation and use.	10-55Hz , 15mm amplitude. 60 sec in each of 3 directions X,Y,Z For 15 minutes	3
Static electricity test	Endurance test applying electric static discharge.	VS=800V, RS=1.5kΩ, CS=100pF One time	

Note 1: No condensation to be observed.

Note 2: Conducted after 4 hours of storage at 25°C, 0%RH.

Note 3: Test performed on product itself, not inside a container.

Precautions for using LCDs/LCMs

See Precautions at www.newhavendisplay.com/specs/precautions.pdf

Warranty Information and Terms & Conditions

http://www.newhavendisplay.com/index.php?main_page=terms