

TOLERANCE:

+10mm
-10mm

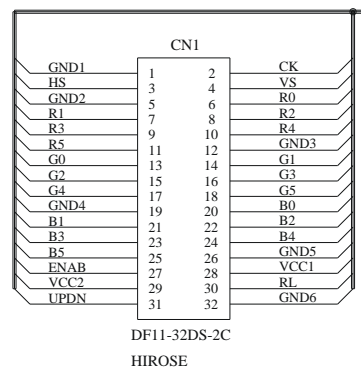
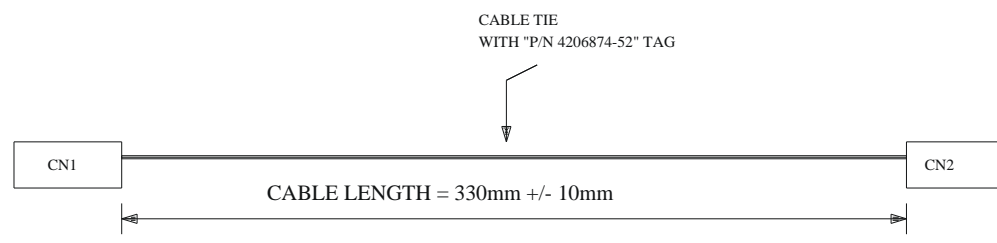

CONNECTOR:
HIROSE, DF11-32DS-2C X 2 PCS
DF11 CRIMP TERMINAL X 64 PCS
TIN PLATED

WIRE: 330mm
UL1571 AWG28, RED X 1 PC
UL1571 AWG28, BLACK X 31 PCS

CONNECTION:
ONE TO ONE

LABELING:
A P/N LABEL SURROUNDED AT THE MIDDLE OF PIN 1

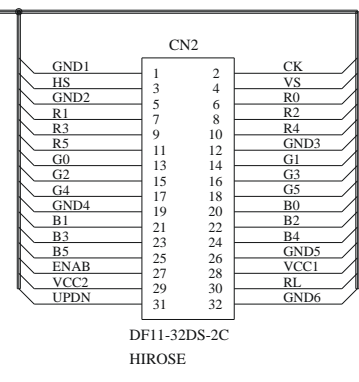

USAGE: PANEL CABLE FOR SHARP 15" AND 18" PANEL

CABLE P/N: 4206874-52
NAME: DF11-32WAY, 330mm

DIGITAL VIEW LTD.		
COPYRIGHT 2000, ALL RIGHTS RESERVED		
CONFIDENTIAL		
DRAWN BY: KENNETH TSANG		
Title PANEL CABLE: DF11-32WAY, 330mm		
Size A	Document Number (G:_D\DV_CABLE\C0687452.SCH)	REV 02
Date: July 19, 2000	Sheet 1	of 1