

UNCONTROLLED DOCUMENT

UNDER REVISION

SC:0.25	PART NUMBER	REV.
	SSH-LX5091	D
REV.	E.C.N. NUMBER AND REVISION COMMENTS	DATE
A	E.C.N. #10BRDR. & REDRAWN.	04.01.99
B	E.C.N. #10525.	06.24.99
C	E.C.N. #11496.	04.10.08
D	E.C.N. #11526.	08.15.08

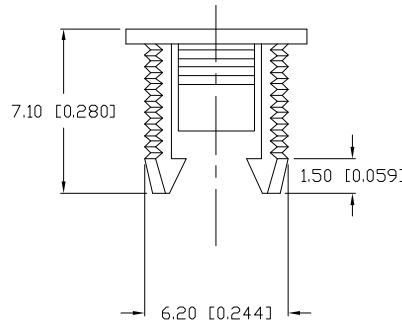
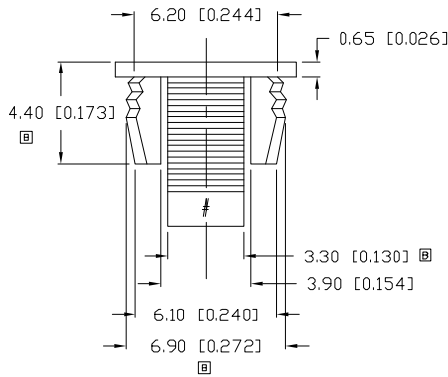
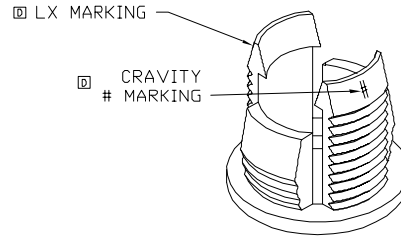
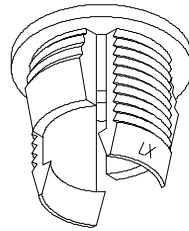
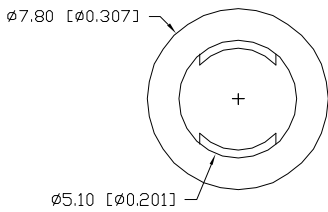

NOTES:

1. MATERIAL: BLACK PP.
2. PANEL CUTOUT: 1/4".
3. PANEL THICKNESS: 0.050"-0.100".

*UNLESS OTHERWISE SPECIFIED TOLERANCES PER DECIMAL PRECISION ARE: X=±1 (±0.039), X.X=±0.5 (±0.020), X.XX=±0.25 (±0.010), X.XXX=±0.127 (±0.005). LEAD SIZE=±0.05 (±0.002), LEAD LENGTH=±0.75 (±0.030), MIN=+DECIMAL PRECISION MAX=-0.00 -DECIMAL PRECISION

UNCONTROLLED DOCUMENT

REV. D	PART NUMBER SSH-LX5091	<p>CONFIDENTIAL INFORMATION</p> <p>THE INFORMATION CONTAINED IN THIS DOCUMENT IS THE PROPERTY OF LUMEX INC. EXCEPT AS SPECIFICALLY AUTHORIZED IN WRITING BY LUMEX INC., THE HOLDER OF THIS DOCUMENT SHALL KEEP ALL INFORMATION CONTAINED HEREIN CONFIDENTIAL AND SHALL PROTECT SAME IN WHOLE OR IN PART FROM DISCLOSURE AND DISSEMINATION TO ALL THIRD PARTIES.</p> <p>RELIABILITY NOTE</p> <p>OUR MANY YEARS OF EXPERIENCE DATA ACCUMULATION INDICATE THAT SOLDER HEAT IS A MAJOR CAUSE OF EARLY AND FUTURE FAILURE. PLEASE PAY ATTENTION TO YOUR SOLDERING PROCESS.</p>	 <p>290 E. HELEN ROAD PALATINE, IL 60067-6976 PHONE: +1.847.359.2790 US WEB: www.lumex.com TW WEB: www.lumex.com.tw</p>
LED PANEL HOLDER FROM 5mm (T-1 3/4) LED, BLACK POLYPROPYLENE.		<p>DRAWN BY: CK/BC</p> <p>CHECKED BY:</p> <p>APPROVED BY:</p>	<p>DATE: 09.22.93</p> <p>PAGE: 1 OF 1</p> <p>SCALE: N/A</p>