

Micro Dual Serial Motor Controller

User's Guide

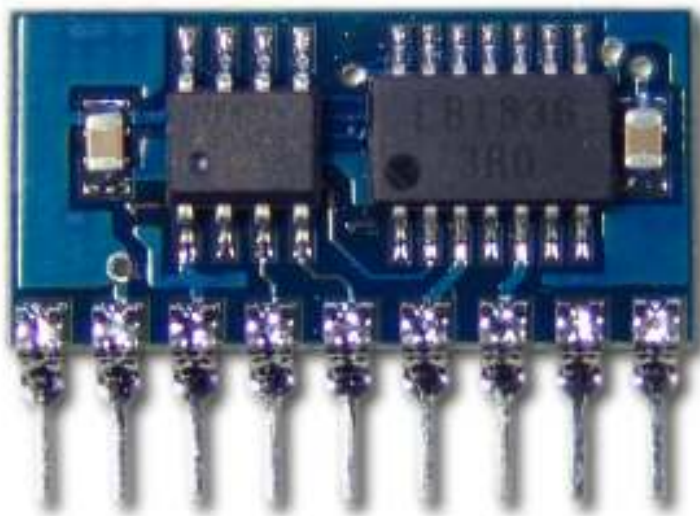

Contents:

- Safety Warning
- Contacting Pololu
- Module Pinout
- Connecting the Motor Controller
- Basics of the Serial Interface
- Configuring the Motor Controller
- Using the Motor Controller
- Example BASIC Stamp II Program
- Troubleshooting Tips
- How the Motor Controller Works
- Description and Specifications



© 2004
<http://www.pololu.com/>

SMC02B



Important Safety Warning

The motor controller module is not intended for young children! Younger users should use this module only under adult supervision. **By using this product, you agree not to hold Pololu liable for any injury or damage related to the use or to the performance of this product. This product is not designed for, and should not be used in, applications where the malfunction of the product could cause injury or damage.**

Contacting Pololu

You can check the Pololu web site at <http://www.pololu.com/> for the latest information about the motor controller, including color pictures, application examples, and troubleshooting tips.

We would be delighted to hear from you about your project and about your experience with our motor controller. You can contact us through our online feedback form or by email at support@pololu.com. Tell us what we did well, what we could improve, what you would like to see in the future, or anything else you would like to say!

Module Pinout

The function of each of the nine module pins is listed in the table below. With the module components facing you and the pins facing down, the pins are numbered left to right.

PIN	FUNCTION
1	motor supply (1.8-9.0 V)
2	ground (0 V)
3	logic supply (2.5-5.5 V)
4	serial control input
5	reset
6	motor 1, positive output
7	motor 1, negative output
8	motor 0, negative output
9	motor 0, positive output

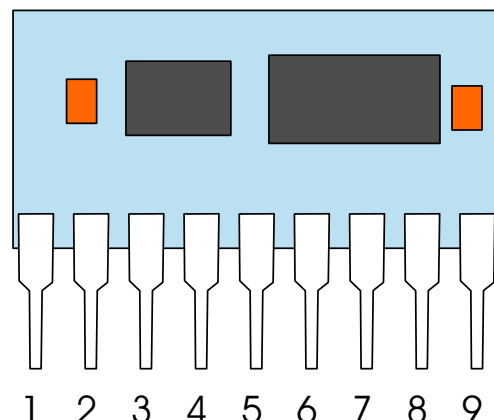

Connecting the Motor Controller

The motor controller module has pins with a standard 0.1" spacing. You can hook up your motor controller with a solderless breadboard, by soldering wires directly onto the pins, or even with your own custom printed circuit board. You can also use a socket to allow you to plug your motor controller in without directly soldering it.

Connecting Power (pins 1-3). Connect the ground pin (pin 2) to a ground terminal on your main controller unit and to the negative terminal of your motor power source. Connect the positive terminal of your motor power source to pin 1. Connect your logic power supply to pin 3. The logic power supply is the voltage at which your main controller operates, such as 5 V. You can connect the same power source to both logic and motor supplies. For example, if you are using a microcontroller that can run at 4.5 V, you could run both your logic and motors off of three 1.5-volt batteries. **Warning:** make sure the motor supply does not exceed 9 volts and the logic supply does not exceed 5.5 volts.

Reset Input (pin 5). The reset input must be kept high (at the logic supply voltage) for the motor controller to operate; bringing it low (to 0 V) for at least 2 microseconds resets the motor controller to its initial state (all motors off, waiting for its first serial command). Connect this pin to a digital output on your main controller. If you do not want to use the reset line, connect it through a 4.7 kOhm resistor to your logic supply. We strongly recommend using the reset line; you might also use a pull-down resistor on the reset line so that if your main controller gets reset, the motors do not keep running.

Serial Input (pin 4). Use a pin on your main controller that can be used as a logic-level, asynchronous serial output. Serial data can be sent down this line 8 bits at a time, with no parity bit, at any rate between 1200 and 19200 baud. *Once you choose a baud rate, you cannot change it until the motor controller is reset.* **Important note:** unlike RS-232 serial lines (the standard for serial ports used to connect devices to personal computers), this line uses logic voltages between 0 and the supply voltage. The higher voltages used on RS-232 lines will damage the motor controller. If you need to convert RS-232 levels to TTL levels, you will need to use a level converter such as the MAX220 (made by Maxim). You could also use the simple circuit shown below. **When building circuits that connect to a PC, be especially careful because you could potentially destroy the PC's serial port. Before attempting to connect your own electronics to a computer, make sure you know what you are doing!**

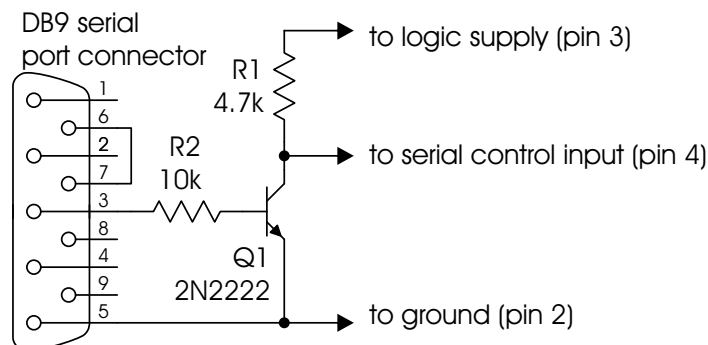

Connecting the Motors in Dual Motor Mode (pins 6-9). If you are using your motor controller to control two independent motors, connect one or two motors to pins 6 through 9. You probably don't need to worry too much about the polarity, but pins 6 and 9 go positive when the controller receives "forward" commands. If you find out that your motors turn in different directions than you expect, you can flip the wiring or just switch the forward and reverse commands on your robot controller program.

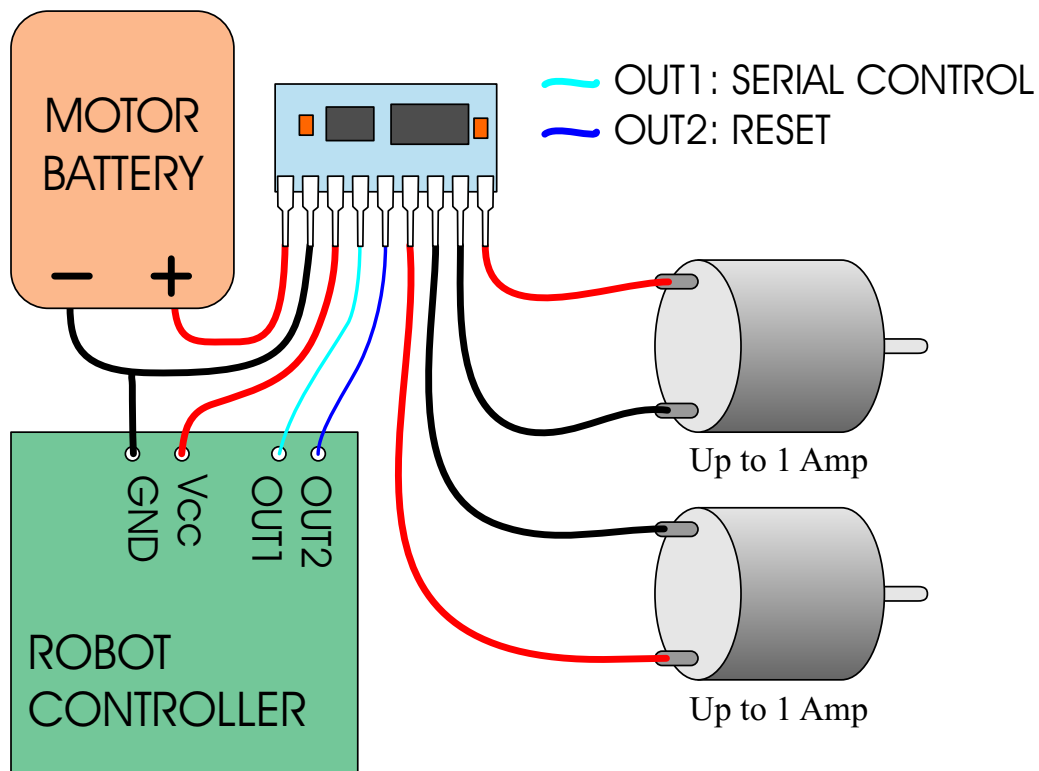

A typical two-motor setup.

The green box labeled "robot controller" represents a main control unit that includes a battery that is not shown. This robot controller could be a microcontroller or a device such as the BASIC Stamp from Parallax. Keep in mind that the wiring you use for the motor outputs and power connections should be capable of conducting several amps. We recommend using at least 26 gauge wire (remember, smaller numbers mean bigger wires!).

Connecting One Motor in Single Motor Mode (pins 6-9). If you are using your motor controller to control a single motor, you must use pins 6 through 9. Before connecting the single motor, make sure that you have configured the motor controller for single motor mode. Connect pins 6 and 9 to one motor lead, and connect pins 7 and 8 to the other motor lead. **If you make these connections in dual-motor mode, you could destroy your motor controller!**

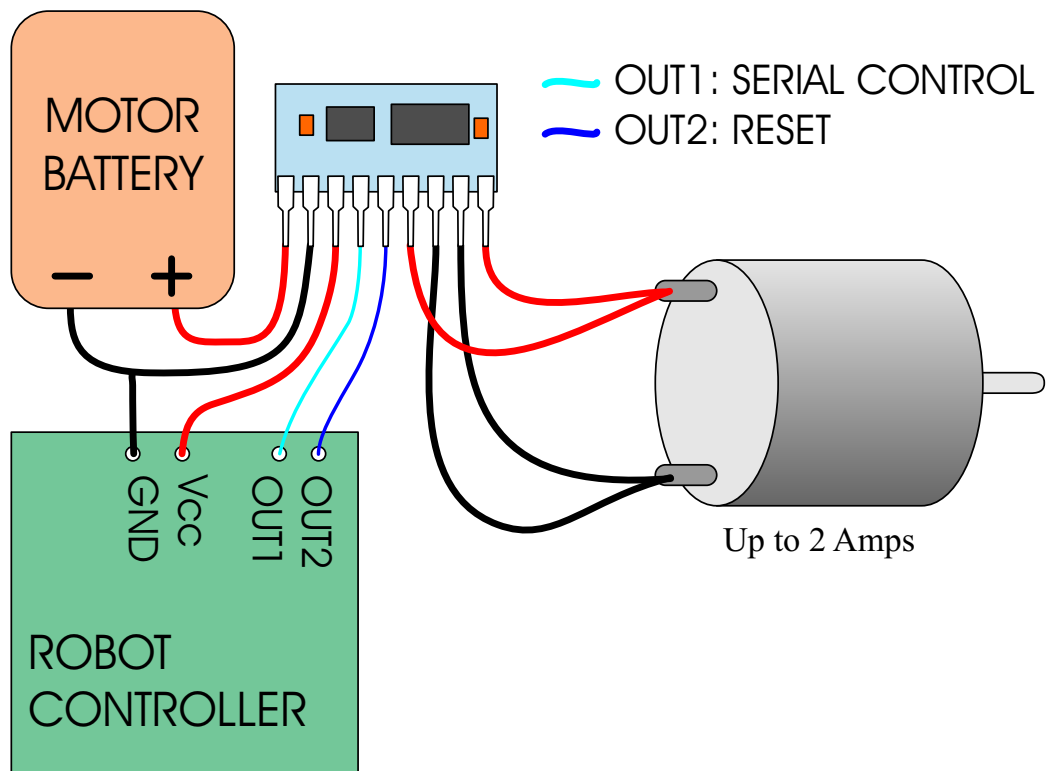

A typical single-motor setup.

In this configuration, the two H-bridges of the motor controller are wired in parallel. Single-motor mode must be used to ensure that the two H-bridges are also controlled in parallel. This setup allows up to 2 A to be delivered to the motor.

The green box labeled "robot controller" represents a main control unit that includes a battery that is not shown. This robot controller could be a microcontroller or a device such as the BASIC Stamp from Parallax. Keep in mind that the wiring you use for the motor outputs and power connections should be capable of conducting several amps. We recommend using at least 26 gauge wire (remember, smaller numbers mean bigger wires!).

Basics of the Serial Interface

The motor controller uses a serial interface to communicate with a main controller, which could be a small microprocessor or a desktop computer. To use the motor controller, you must program your main controller to send data with the correct format to the motor controller's asynchronous serial input, pin 4.

The motor controller expects eight bits at a time (with no parity bit) at a constant baud rate ranging from 1200 to 19200 baud (the motor controller will automatically detect the baud rate). The serial bits must be at logic levels and *non-inverted*, meaning that a zero is sent as a low voltage, and a one is sent as a high voltage, as shown in the diagram to the right. (The PC-connection circuit on page 3 corrects the inverted signal coming out of PC serial ports.) *Commands sent to the serial input **must** conform to the above format or else the motor controller and other devices connected to the serial line may behave unexpectedly.*

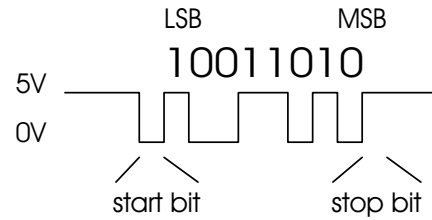

Once you can send individual bytes correctly, you must send the correct sequence of bytes to get the motor controller to run your motors. This motor controller *interface protocol* is compatible with other Pololu serial devices such as our servo controller, so you can control multiple Pololu serial devices on a single line. The protocol requires one start byte, a one-byte device identifier, and then any number of bytes, as required by the device specified in the second byte:

start byte = 0x80	device type	data byte 1	data byte 2
-------------------	-------------	-------------	-------------

The start byte is identified by its most significant bit being set; all subsequent bytes must have bit 7 clear, giving them possible values of 0 to 0x7F (0 to 127 decimal). Whenever a byte is transmitted on the serial line, all devices on that line check to see if the byte is the start byte; if it is, then all devices check the next byte to see if the data is meant for them. All subsequent bytes, the data bytes in the diagram above, are only interpreted by the appropriate devices, while all other devices wait for a new start byte.

If you did not understand all of the details above and you just want to use your motor controller, don't worry. You just need to use the right serial settings and send the correct sequences of bytes, as described on the following pages.

Summary: Use non-inverted, logic-level serial transmission at baud rates between 1200 and 19200, 8 bits at a time with no parity and one stop bit.



Resetting the Motor Controller

The motor controller's reset line should normally be kept high at the logic supply voltage. Pull the reset line low to 0 V for at least 2 microseconds to reset the motor controller to its initial state (all motors off, waiting for the first serial command). If you do not want to use the reset line, connect it through a 4.7 kOhm resistor to your logic supply. We strongly recommend using the reset line; you might also use a pull-down resistor on the reset line so that if your main controller gets reset, the motors do not keep running. **After turning on the motor controller or resetting it, allow 100 ms for it to start up before sending any serial data.**

Controlling Multiple Motor Controllers with One Serial Line

To control a particular motor, you must specify its motor number in command byte 3. Regardless of configuration, every motor controller responds to commands for motor number 0, and, in two-motor mode, to motor 1. To control more than two motors with a single serial line, you need to use motor numbers 2 through 63. Configure each motor controller to respond to different motor numbers, then connect them to the same serial line; each motor controller will respond only to the motor number to which it is configured. After you configure a motor controller, you can write its motor number on the label on the back to keep track of your motor numbers.

For example, to control six motors independently with dual-motor mode, you need three motor controller boards, each with different motor numbers. All three motor controllers respond to commands for motor numbers 0 and 1. For controlling the six motors independently, use motor numbers 2, 3, 4, 5, 6, and 7. (In single-motor mode, you would need six motor controllers configured to numbers 1 through 6 since only motor number 0 is a universal motor number.)

Example BASIC Stamp II Program

The program on the next page, which can run on a BASIC Stamp II controller, makes motor 1 gradually speed up, then slow down, then speed up in the other direction, and then slow down again. For the code to work, pin 15 must be connected to the reset input (pin 5), and pin 14 must be connected to the serial input (pin 4). The interface code should look similar in other programming languages; the description below should help you in understanding the code and, if necessary, in translating it to other languages.

On line 1, the 8-bit variable `speed` is declared for later use. The serial line is then taken high, to its idle state, before the motor controller is reset by a low-going pulse on pin 15 (lines 3 and 4). A 100-ms pause on line 5 ensures that the motor controller is up and running before any serial data is sent to it.

The first *for loop* on lines 6-9 causes motor 1 to gradually speed up. The serial output is created by the `serout` statement on line 7. The first parameter, 14, specifies the pin number through which to send the serial signal. The next parameter, 84, sets up the serial characteristics to be 8 bits with no parity, non-inverted, at a baud rate of 9600. The four numbers in square brackets are the data to be sent, and they correspond to the



© 2004

<http://www.pololu.com/>

Example BASIC Stamp II Program (continued)

four control bytes for the motor controller. The first two bytes should always be \$80 and 0. The second 0 makes motor 1 go backward. The speed variable, which increases every time through the loop, is the only part of the command that changes, and that is what makes the motor gradually speed up. The `pause` statement on line 8 causes the program to wait for 20 ms (0.02 seconds) before sending the next command.

When the first loop ends, the motor is set to its full speed of 127. The second loop on lines 10-13 slows the motor back down by sending speeds from 127 down to 0. The next two loops on lines 14-21 then repeat the process, except for the parameter value of 1 in byte three, which causes motor 1 to spin forward.

```
1      speed  var  byte
2      high 14      `take serial line high
3      low 15      `reset motor controller
4      high 15
5      pause 100   `motor controller startup time
6      for speed = 0 to 127
7          serout 14,84,[$80, 0, 0,speed]
8          pause 20
9      next
10     for speed = 127 to 0
11         serout 14,84,[$80, 0, 0,speed]
12         pause 20
13     next
14     for speed = 0 to 127
15         serout 14,84,[$80, 0, 1,speed]
16         pause 20
17     next
18     for speed = 127 to 0
19         serout 14,84,[$80, 0, 1,speed]
20         pause 20
21     next
```

Troubleshooting Tips

All motor controllers are fully tested prior to shipment; if your motor controller does not work at first, it can be difficult to determine the cause because there is no output besides the motor outputs to determine the state of the motor controller: a broken unit will look just like a working one, and the only difference you can detect between the two is that one works and the other doesn't! Nevertheless, patience and meticulous attention to detail, along with these few tips, should usually help you through.

- Double check all of your connections. Are your logic and motor supply grounds connected? If you are using a breadboard or sockets, are the motor controller pins all making good contact?



Troubleshooting Tips (continued)

- Double check your code. Are your baud rate settings correct? If you cannot get your design working with the top baud rate of 19200, try lowering it to 9600, where slight timing mismatches are less likely to frustrate your efforts.
- Are you using the correct motor number? If nothing seems to be working, start by using motor number 0, which should work regardless of the configuration.
- Are you using good power supplies? Especially if you are using multiple motor controllers, make sure your logic power supply can deliver the necessary current (approximately 20 mA per motor controller). Do not use regulated power for your motor supply.
- If your motors unexpectedly run for a second then stop for a second and repeat, your motor controller is probably overheating, and the thermal protection feature is being activated. You can help the situation by putting a heat sink on the motor driver chip, lowering your motor supply voltage, and putting short stops between changes in motor direction.

How the Motor Controller Works

The motor controller uses *H-bridges* to turn motors forward and backward (see the dotted 'H' in the left figure). H-bridges have four switches, which are turned on in pairs to allow current to flow into the motors in both directions, as shown below. In the left figure, all four switches are open, and the motor is turned off. When switches 1 and 4 close, the motor turns in one direction; when switches 2 and 3 close, the motor turns the other way. The dual serial motor controller contains two H-bridges, allowing bidirectional control of two motors.

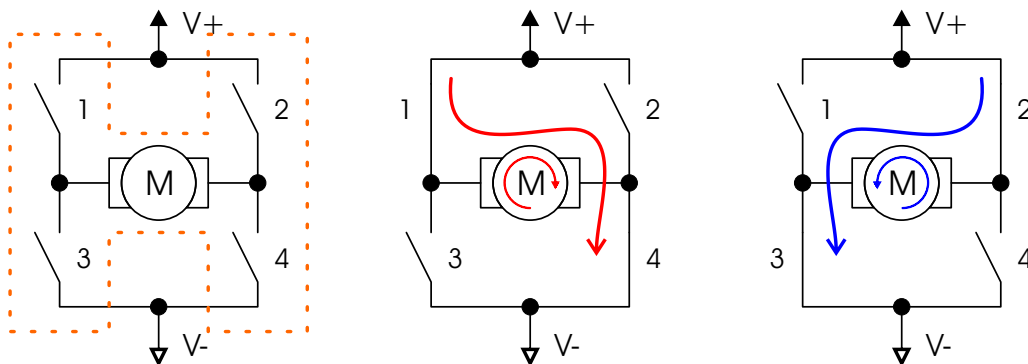

A technique called *pulse width modulation* (PWM) is used to control the speed of the motors. A little computer called a microcontroller (the 8-pin black component) controls the H-bridge switches. It turns the switches on and off very rapidly (600 times per second) and varies the percentage of the time that the switches are on to achieve the speed set by the serial interface. For a higher speed, the switches are on a larger fraction of the time than for a slower speed. At the maximum speed of 127, the switches are left on. The momentum of the motor shaft keeps the shaft spinning at a constant speed that can be varied smoothly over all 127 different speeds.



The Pololu Micro Dual Serial Motor Controller

For a robot to interact with its environment, it must be able to convert electrical signals into motion. However, the power requirements of *actuators*, electrical devices capable of producing motion, are typically so high that normal digital circuitry cannot drive them. In addition, precise motion control requires constantly changing the signals sent to the actuators, leaving the control circuitry with little time to attend to other tasks.

The Pololu motor controller bridges the gap between robot controllers and power-hungry actuators. Using one serial output from your robot controller, you can independently set each of two small DC motors (the kind typically found in remote-control cars and motorized toys) to go forward or backward at any of 127 different speeds. To control additional motors, you can connect multiple motor controllers to the same serial line. The motor controller is compatible with the Pololu Servo Controller, so you can control an almost unlimited number of motors and servos with one serial line.

Because of its small size, the motor controller is especially suited for small robots and mechanisms that use small motors that run at low voltages. With this motor controller, you can make a robot that runs off of just two 1.5 V batteries or three 1.2 V rechargeable cells!

Specifications

PCB size.....	0.90" x 0.45"
Motor ports.....	2
Speeds.....	127 forward and backward, off, brake
Maximum current.....	two motors 1 A each, one motor 2 A
Motor supply voltage.....	1.8-9.0 V
Logic supply voltage.....	2.5-5.5 V
PWM frequency.....	two motors 600 Hz, one motor 750 Hz
Serial baud rate.....	1200-19200 (automatically detected)

