

# 6100

# Hysteresis Motor

Model 6100

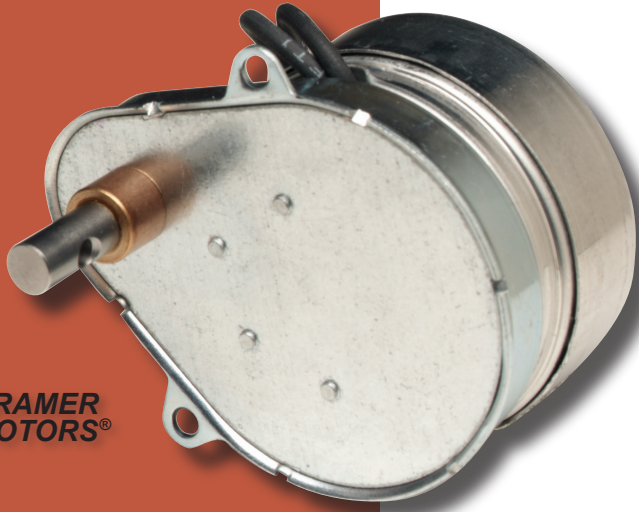

**CRAMER  
MOTORS®**

*Cramer's AC Hysteresis Motor is a shaded pole, synchronous-type that provides smooth, quiet performance and allows operation to a stall condition without damage or increase in temperature. External rear bearing provides stability and strength and allows for a double-ended output shaft that can be configured with pinions, levers, flats or knurls. The pear-shaped gearbox is designed to contain a wide range of gear ratios.*

### Applications Include:

- HVAC Controls • Point of Purchase • Animated Display Drives
- Automatic Teller Machines

### Similar Products By Cramer:



DC Permanent Motors Model 800



AC Permanent Motors  
Models 105, 107, and 113

### Features:

- Rear output bearing is external and larger than most other motors, resulting in the ability to handle higher side loads
- Designed with a stall torque performance feature, eliminating motor damage or increase in temperature
- Quiet operation and back drive capability
- Optional extended shafts available for manual rotation of motor or actuator
- Optional double-ended shafts available for actuation of two devices
- Lifetime lubrication

### Performance Data: Torque Rating (typical) @ 1 RPM, 60 Hz (oz. in.)

Model	5 Watt
Starting Torque @ 1 RPM	30 oz. in.
Running Torque @ 1 RPM	60 oz. in.
Operating Temperature Range	-40°F to 212°F
	-40°C to 100°C
Insulation Class	UL Class F Rating (155°C)
Voltage Offered	24, 120, and 240 (50 & 60 Hz) VAC
Standard Speeds	1, 2, 4, 5 & 6 RPM
Direction of Rotation	CW & CCW



105 Nutmeg Road South  
 South Windsor, CT 06074 USA  
 P: 860.291.8402  
 F: 860.610.0897  
 cramer-motors.com

# Hysteresis Motor

## Exclusive Market Design Features:

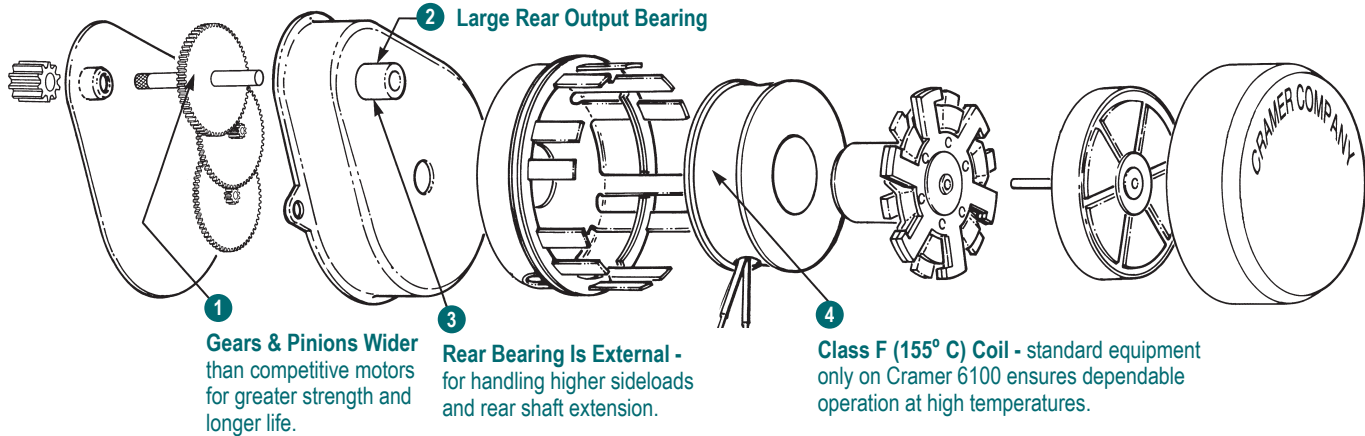

## Shaft Selection Data:

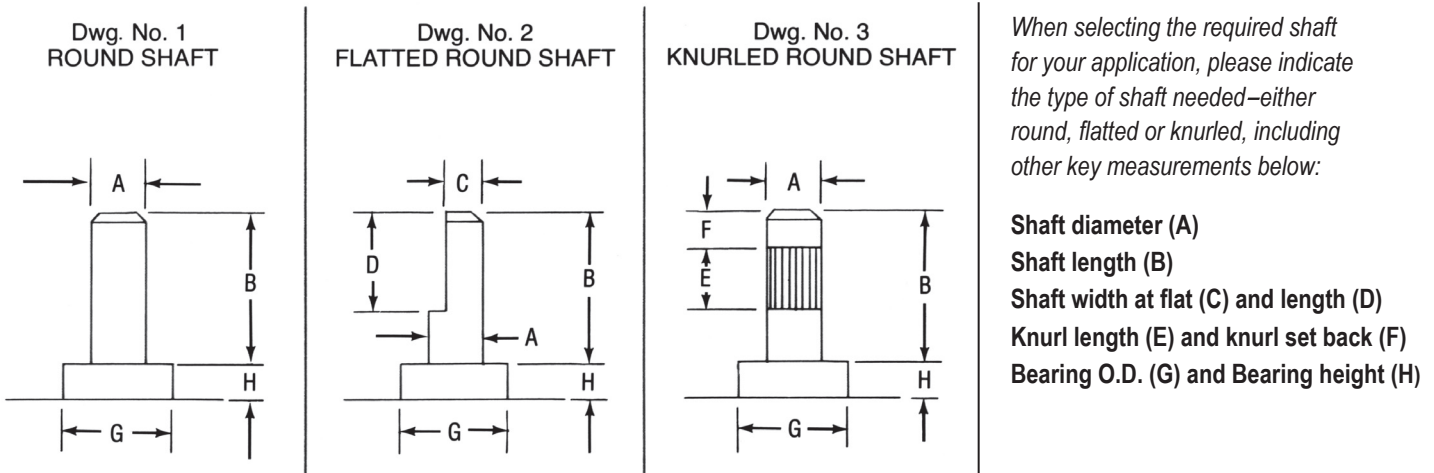

## Motor Selection:

When specifying a motor for meeting your application, Cramer Company requires information such as torque, speed requirements, voltage, shaft dimensions and shape, direction of rotation and other key performance values.

To assist you in specifying the requirements above, please visit [cramer-motors.com](http://cramer-motors.com) or call our sales staff and request a specification worksheet for completing the information.

**Warranty:** Cramer warrants its products against defective material or workmanship for a period of one year from the date of shipment from factory, providing product has been used in accordance with instructions and specified ratings. Consult factory for further details concerning our warranty policy.

## Motor Dimensions:

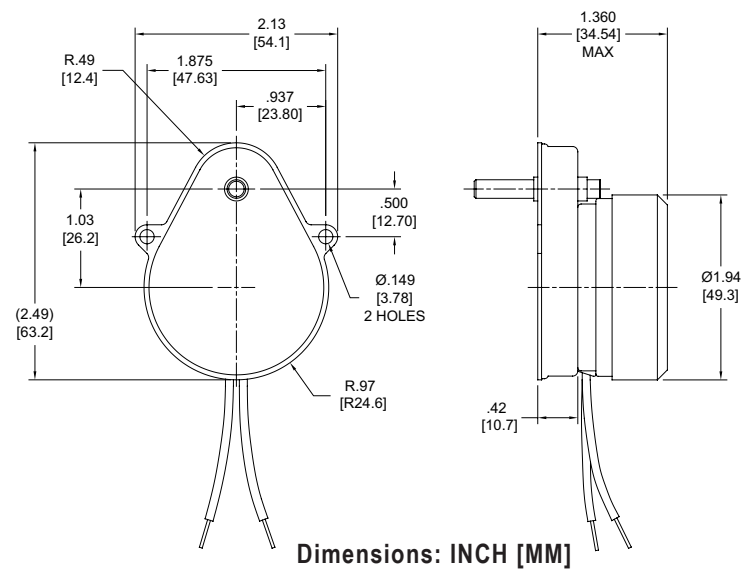

105 Nutmeg Road South • South Windsor, CT 06074 USA  
P: 860.291.8402 • F: 860.610.0897 • [cramer-motors.com](http://cramer-motors.com)