

800

# DC Permanent Magnet Motors

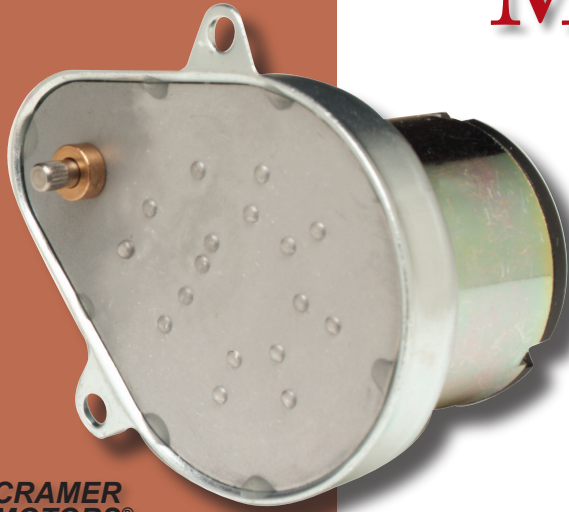

CRAMER  
MOTORS®

Model 800

*The Cramer line of DC Permanent Magnet Motors offers application solutions requiring fast starts, high starting torque and drive reversibility.*

## Applications:

- Warning Lights • Graphic Plotters • Automatic Teller Machines • Printers
- Medical Pump and Drive Values • Transit Ticket Dispensers • Card Readers

## Features:

- High torque capability • Fast starting and stops
- Clockwise and Counter Clockwise rotation available
- Clutches available are One-Way Incremental, or Two-Way Slip
- Pear-shape and round-gear case available

## Similar Products By Cramer:



Hysteresis Motors Model 6100



AC Permanent Magnet Motors  
Models 105, 107, and 113

**CRAMER  
COMPANY**

Precision Timers and Motion Devices

105 Nutmeg Road South  
South Windsor, CT 06074 USA

P: 860.291.8402

F: 860.610.0897

cramer-motors.com

## Specifications: Rating Data (Ounce Inches @ 1 RPM)

### Model 800

Starting Torque* @ 1 RPM	60 oz. in.
Running Torque** @ 1 RPM	60 oz. in.
Current Input (No load)	as low as 18 ma.
Standard Voltages	4 - 24 VDC
Noise Suppression	Varistor type
Standard Mounting	2 hole
Mounting Centers (Round)	2.125 inches
Mounting Centers (Pear Shaped)	1.875 inches
Gear Train Rating - Dynamic*** (Standard Duty)	30 oz. in.
Gear Train Rating - Static**** (Standard Duty)	90 oz. in.
Operating Temperature Range	+77°F to 185°F
	+25°C to 85°C

\*Starting Torque is the Torque Load the motor can accelerate from rest.

\*\*Running torque is the load the motor can drive after obtaining rated motor speed.

\*\*\*Dynamic Torque is the maximum load, that the gear train can drive continuously without undue wear.

\*\*\*\*Static Torque is the maximum torque load that can be sustained without risk of damage to the gear train.

# DC Permanent Magnet Motors

## Pear-Shaped Gear Case:

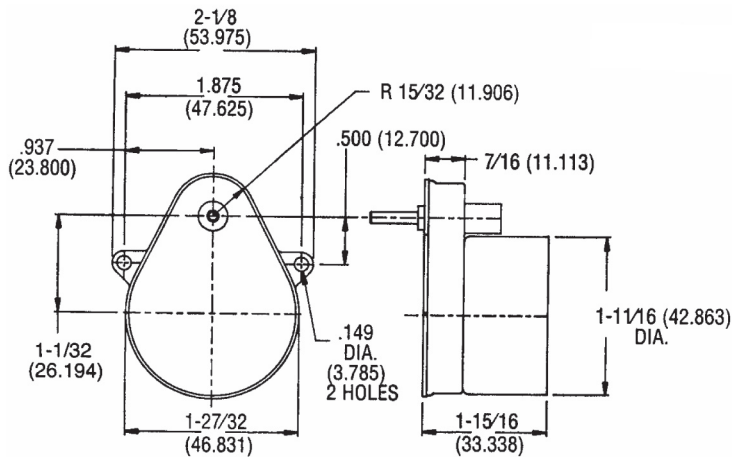

## Round-Shaped Gear Case:

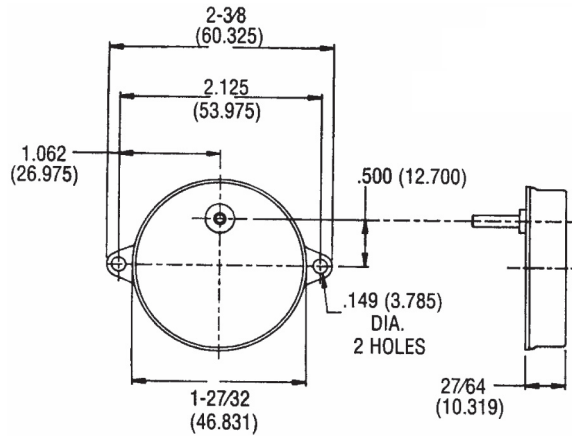

Dimensions: INCH [MM]

## Shaft Selection Data:

Dwg. No. 1  
ROUND SHAFT

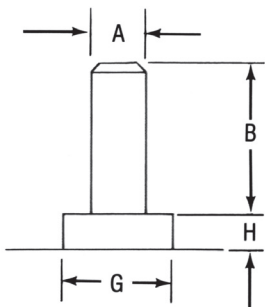

Dwg. No. 2  
FLATTED ROUND SHAFT

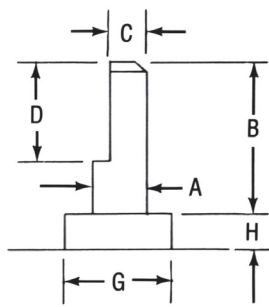

Dwg. No. 3  
KNURLED ROUND SHAFT

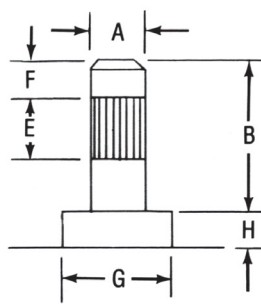

When selecting the required shaft for your application, please indicate the type of shaft needed—either round, flatted or knurled, including other key measurements below:

Shaft diameter (A)

Shaft length (B)

Shaft width at flat (C) and length (D)

Knurl length (E) and knurl set back (F)

Bearing O.D. (G) and Bearing height (H)

## Motor Selection:

When specifying a motor for meeting your application, Cramer Company requires information such as torque, speed requirements, voltage, shaft dimensions and shape, direction of rotation and other key performance values.

To assist you in specifying the requirements above, please visit [cramer-motors.com](http://cramer-motors.com) or call our sales staff and request a specification worksheet for completing the information.

**Warranty:** Cramer warrants its products against defective material or workmanship for a period of one year from the date of shipment from factory, providing product has been used in accordance with instructions and specified ratings. Consult factory for further details concerning our warranty policy.

**CRAMER**  
**COMPANY**

A Division of Capewell Components Company LLC

105 Nutmeg Road South • South Windsor, CT 06074 USA

P: 860.291.8402 • F: 860.610.0897 • [cramer-motors.com](http://cramer-motors.com)