

FAN1851A

Ground Fault Interrupter

Features

- Improved performance over industry equivalents
 - Tight fault current range (Typ $\pm 100\mu\text{A}$)
 - Temperature compensated fault current characteristics
 - No external trimming required
- Direct interface to SCR
- Supply voltage derived from AC line—26V shunt
- Adjustable sensitivity
- Grounded neutral fault detection
- Meets UL943 standards
- 450 μA quiescent current
- Ideal for 120V or 220V systems
- Package options: 8L DIP and 8L SOIC

Description

The FAN1851A is a controller for AC outlet ground fault interrupters. These devices detect hazardous grounding conditions (example: a pool of water or an electrical equipment connected to opposite phases of the AC line) in consumer and industrial environments. The output of the IC triggers an external SCR, which in turn opens a relay circuit breaker to prevent a harmful or lethal shock.

Full advantage of the U.S. UL943 timing specification is taken to ensure maximum immunity to false triggering due to line noise. A special feature in the circuitry rapidly resets the integrating timing capacitor in the event that noise pulses introduce unwanted charging currents. Also, a flip-flop is included that ensures firing of even a slow circuit breaker relay on either of the two half-cycles of the line voltage when external full wave rectification is used.

The application circuit can be configured to detect both normal faults (hot wire to ground) and grounded neutral faults.

Block Diagram

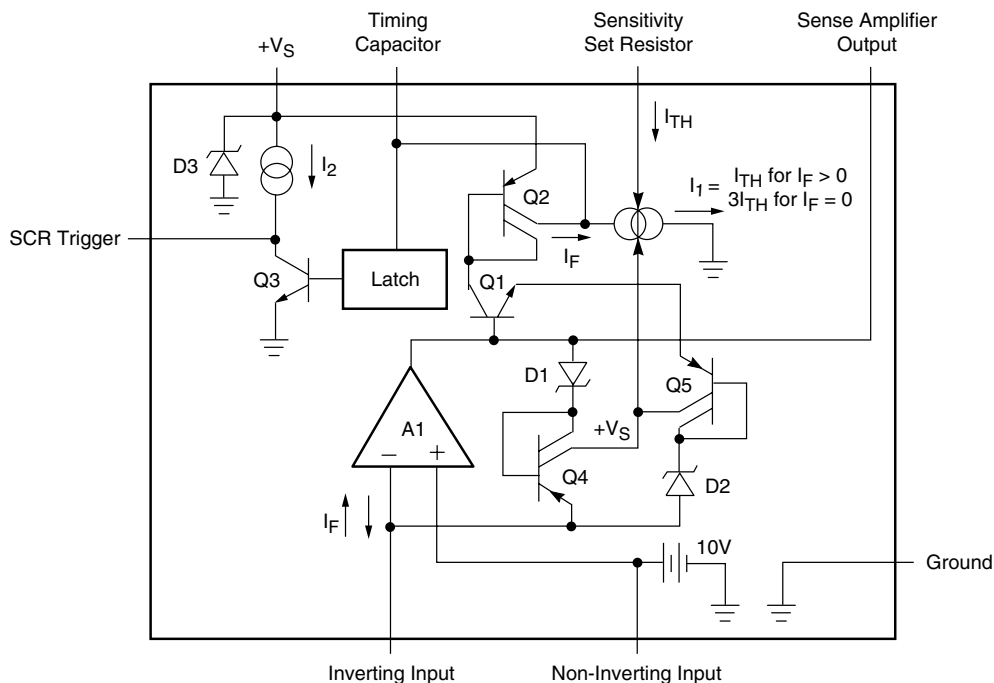

Pin Assignments

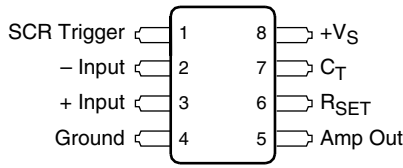

Functional Description

The voltage at the supply pin is clamped to +26V by the internal shunt regulator D3. This shunt regulator also generates an artificial ground voltage for the noninverting input of A1 (shown as a +10V source). A1, Q1, and Q2 together act as a current mirror for fault current signals (which are derived from an external transformer). When a fault signal is present, the mirrored current charges the external timing capacitor until its voltage exceeds the latch trigger threshold (typically 17.5V). When this threshold is exceeded, the latch engages and Q3 turns off, allowing I₂ to drive the SCR connected to the "SCR Trigger" pin.

Extra Circuitry in the feedback path of A1 works with the switched current source I₁ to remove any charge on C_T induced by noise in the transformer. If no fault current is present, then I₁ discharges C_T with a current equal to 3 I_{TH},

where I_{TH} is the value of current set by the external R_{SET} resistor. If fault signals are present at the input of A1 (which is held at virtual ground, +10V), one of the two current mirrors in the feedback path of A1 (Q4 and Q5) will become active, depending on which half-cycle the fault occurs. This action will raise the voltage at V_S, switching I₁ to a value equal to I_{TH}, and reducing the discharge rate of C_T to better allow fault currents to charge it.

Notice that I_{TH} discharges C_T during both half-cycles of the line, while I_F only charges C_T during the half-cycle in which I_F exits the "- Input" pin (since Q1 will only carry fault current in one direction). Thus, during one half-cycle, I_F-I_{TH} charges C_T, while during the other half-cycle I_{TH} discharges it.

Definition of Terms

Normal Fault:

An unintentional electrical path, R_B, between the load terminal of the hot line and the ground, as shown by the dashed lines in Figure 1.

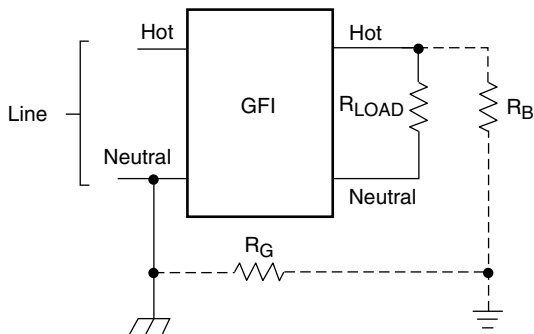

Figure 1. Normal Fault

Grounded Neutral Fault:

An unintentional electrical path between the load terminal of the neutral line and the ground, as shown by the dashed lines in Figure 2.

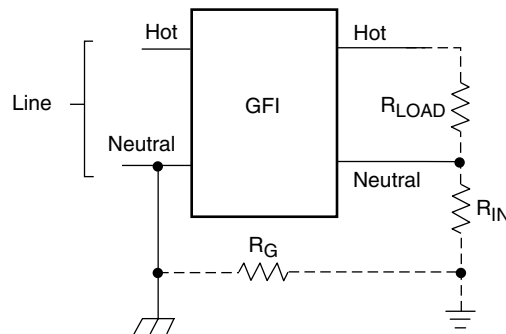

Figure 2. Grounded Neutral Fault

Normal Fault Plus Grounded Neutral Fault:

The combination of the normal fault and the grounded neutral fault, as shown by the dashed lines in Figure 3.

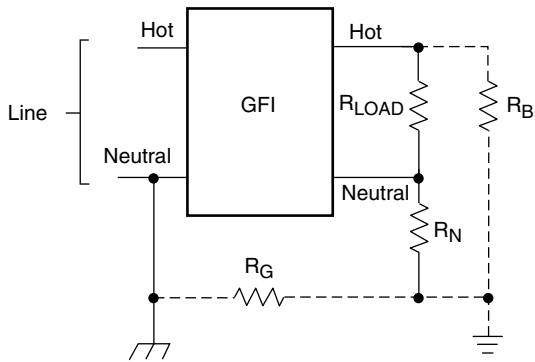

Figure 3. Normal Fault Plus Grounded Neutral Fault

Absolute Maximum Ratings

Parameter	Conditions	Min	Max	Units
Supply Current			19	mA
Power Dissipation			570	mW
Operating Temperature		-40	70	°C
Lead Soldering Temperature, 60 seconds			300	°C

Thermal Characteristics

Parameter	Conditions	Min	Max	Units
Maximum Junction Temperature			125	°C
Maximum P_D	$T_A < 50^\circ\text{C}$		468	mW
Thermal Resistance, θ_{JA}	DIP		85	°C/W
	SOIC		150	

DC Electrical Characteristics

(T_A = +25°C, I_{SHUNT} = 5 mA)

Parameters	Test Conditions	Min	Typ	Max	Units
Power Supply Shunt Regulator Voltage	Pin 8, Average Value	22	26	30	V
Latch Trigger Voltage	Pin 7	15	17.5	20	V
Sensitivity Set Voltage	Pin 8 to Pin 6	6	7	8.2	V
Output Drive Current	Pin 1 With Fault	0.5	1	2.4	mA
Output Saturation Voltage	Pin 1 Without Fault		100	240	mV
Output Saturation Resistance	Pin 1 Without Fault		100		Ω
Output External Current Sinking Capability ¹	Pin 1 Without Fault, V _{PIN1} Held to 0.3V	2	5		mA
Noise Integration Sink Current Ratio	Pin 7, Ratio of Discharge Currents Between No Fault and Fault Conditions	2.0	2.8	3.6	μA/μA

Note:

1. This external applied current is in addition to the internal “output drive current” source.

AC Electrical Characteristics

(T_A = +25°C, I_{SHUNT} = 5 mA)

Parameters	Conditions	Min	Typ	Max	Units
Normal Fault Current Sensitivity ²	See Figure 9	4.75	5	5.25	mA
Normal Fault Trip Time ¹	500Ω Fault, see Figure 10		18		mS
Normal Fault With Grounded Neutral Fault Trip Time ¹	500Ω Normal Fault, 2Ω Neutral, see Figure 10 (Note 1)		18		mS

Notes:

1. Average of ten trials.
2. Required UL System sensitivity tolerance is 4mA to 6mA.

Typical Performance Characteristics (T_A = +25°C)

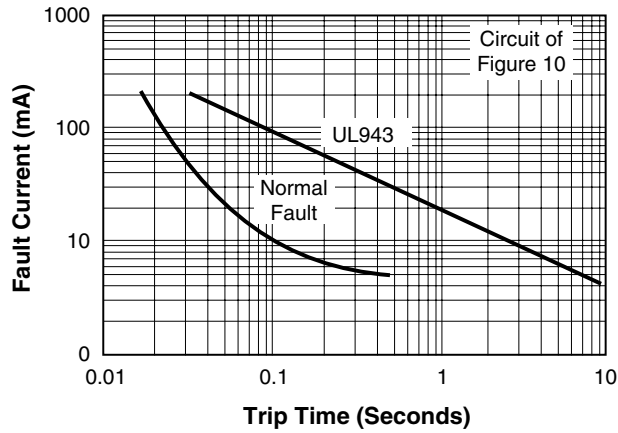

Figure 4. Average Trip Time vs. Fault Current

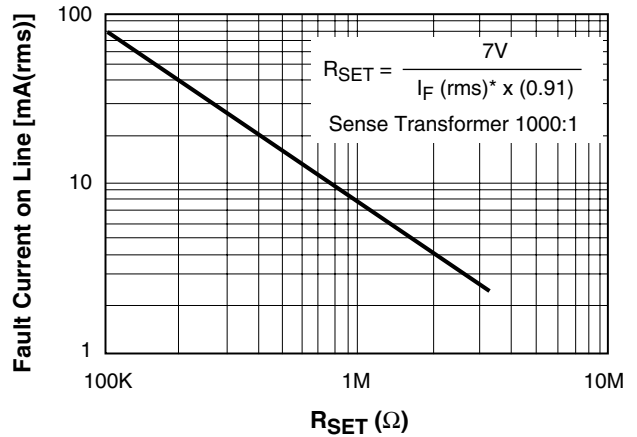

Figure 5. Normal Fault Current Threshold vs. RSET

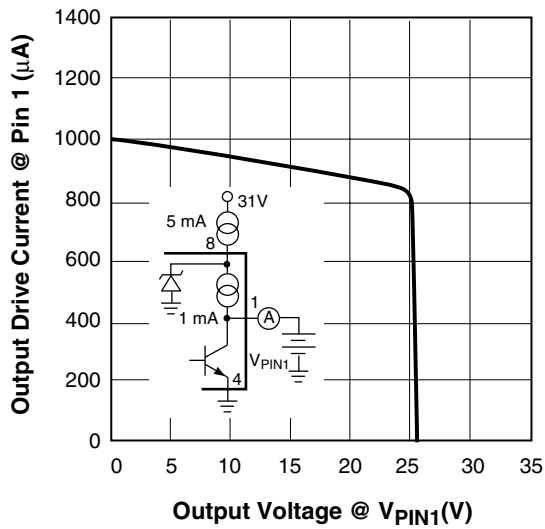

Figure 6. Output Drive Current vs. Output Voltage

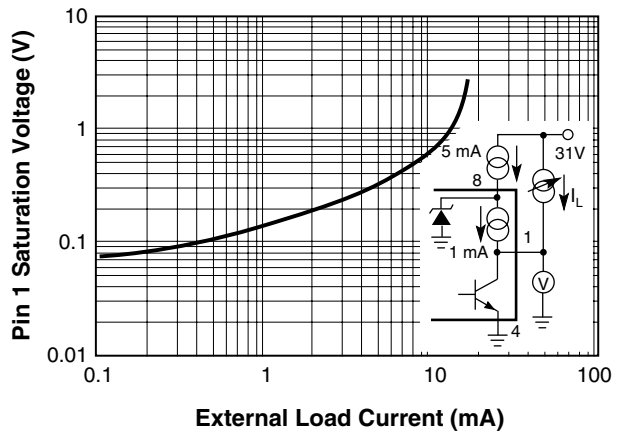

Figure 7. Pin 1 Saturation Voltage vs. External Load Current, I_L

Application Information

A typical ground fault interrupter circuit is shown in Figure 10. It is designed to operate on 120 VAC line voltage with 5mA normal fault sensitivity.

A full-wave rectifier bridge and a 15kΩ/2W resistor are used to supply the DC power required by the IC. A 1 μF capacitor at the "+VS" pin is used to filter the ripple of the supply voltage and is also connected across the SCR to allow firing of the SCR on either half-cycle. When a fault causes the SCR to trigger, the circuit breaker is energized and line voltage is removed from the load.

At this time no fault current flows and the C_T discharge current increases from I_{TH} to 3I_{TH} (see Block Diagram). This quickly resets both the timing capacitor and the output latch. The circuit breaker can be reset and the line voltage again supplied to the load, assuming the fault has been removed. A 1000:1 sense transformer is used to detect the normal fault. The fault current, which is basically the difference in current between the hot and neutral lines, is stepped down by 1000 and fed into the input pin of the operational amplifier through a 10μF capacitor. The 0.0033μF capacitor between the "- Input" pin and the "+ Input" pin and the 200pF capacitor between "+ Input" and "Ground" pins are added to obtain better noise immunity. The normal fault sensitivity is determined by the timing capacitor discharging current, I_{TH}. I_{TH} can be calculated by:

$$I_{TH} = \frac{7V}{R_{SET}} \div 2 \quad (1)$$

At the decision point, the average fault current just equals the threshold current, I_{TH}.

$$I_{TH} = \frac{I_F(\text{rms})}{2} \times 0.91 \quad (2)$$

Where I_F(rms) is the rms input fault current to the operational amplifier and the factor of 2 is due to the fact that I_F charges the timing capacitor only during one half-cycle, while I_{TH} discharges the capacitor continuously. The factor 0.91 converts the rms value to an average value. Combining equations (1) and (2) we have:

$$R_{SET} = \frac{7V}{I_F(\text{rms}) \times 0.91} \quad (3)$$

For example, to obtain 5mA(rms) sensitivity for the circuit in Figure 7 we have:

$$R_{SET} = \frac{7V}{5 \text{ mA} \times 0.91} = 1.5M\Omega \quad (4)$$

The correct value for R_{SET} can also be determined from the characteristic curve that plots equation (3). Note that this is an approximate calculation; the exact value of R_{SET} depends on the specific sense transformer used and FAN1851A tolerances. Inasmuch as UL943 specifies a sensitivity "window" of 4mA to 6mA, a provision should be made to adjust R_{SET} with a potentiometer.

Independent of setting sensitivity, the desired integration time can be obtained through proper selection of the timing capacitor, C_T. Due to the large number of variables involved, proper selection of C_T is best done empirically. The following design example should only be used as a guideline.

Assume the goal is to meet UL943 timing requirements. Also assume that worst case timing occurs during GFI start-up (S1 closure) with both a heavy normal fault and a 2Ω grounded neutral fault present. This situation is shown in Figure 8.

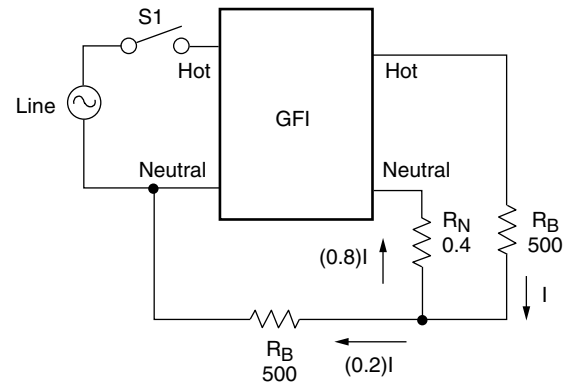

Figure 8. Example

UL943 specifies ≤ 25ms average trip time under these conditions. Calculation of C_T based upon charging currents due to normal fault only is as follows:

1. Start with a ≤ 25ms specification. Subtract 3ms GFI turn-on time (15kΩ and 1μF). Subtract 8ms potential loss of one half-cycle due to fault current sense of half-cycles only.
2. Subtract 4ms time required to open a sluggish circuit breaker.
3. This gives a total ≤ 10ms maximum integration time that could be allowed.
4. To generate 8ms value of integration time that accommodates component tolerances and other variables:

$$C_T = \frac{I \times T}{V} \quad (5)$$

where:

T = integration time

V = threshold voltage

I = average fault current into CT

$$I = \underbrace{\left(\frac{120 V_{AC}(rms)}{R_B} \right)}_{\text{heavy fault current generated (swamps } I_{TH})} \times \underbrace{\left(\frac{R_N}{R_G + R_N} \right)}_{\text{portion of fault current shunted around GFI}$$

$$\times \underbrace{\left(\frac{1 \text{ turn}}{1000 \text{ turns}} \right)}_{\text{current division of input sense transformer}} \times \underbrace{\left(\frac{1}{2} \right)}_{\text{CT charging on half-cycles only}} \times \underbrace{(0.91)}_{\text{rms to average conversion}} \quad (6)$$

therefore:

$$C_T = \frac{\left[\left(\frac{120}{500} \right) \times \left(\frac{0.4}{1.6 + 0.4} \right) \times \left(\frac{1}{1000} \right) \times \left(\frac{1}{2} \right) \times (0.91) \right]}{17.5} \times 0.008$$

$$C_T = 0.01 \mu F \quad (7)$$

In practice, the actual value of C_T will have to be modified to include the effects of the neutral loop upon the net charging current. The effect of neutral loop induced currents is difficult to quantify, but typically they sum with normal fault currents, thus allowing a larger value of C_T. For UL943 requirements, 0.015μF has been found to be the best compromise between timing and noise.

For those GFI standards not requiring grounded neutral detection, a still larger value capacity can be used and better noise immunity obtained. The larger capacitor can be accommodated because R_N and R_G are not present, allowing the full fault current, I, to enter the GFI.

In Figure 10, grounded neutral detection is accomplished by feeding the neutral coil with 120Hz energy continuously and allowing some of the energy to couple into the sense transformer during conditions of neutral fault.

Transformers may be obtained from Magnetic Metals, Inc., (<http://www.magmet.com>).

Application Circuits

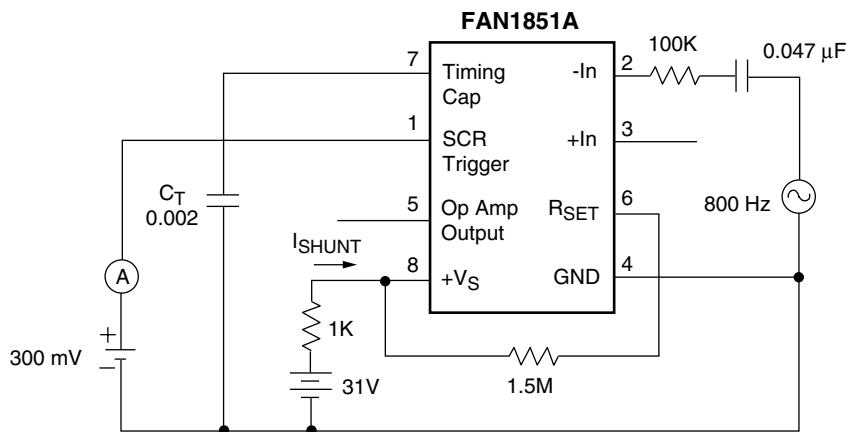
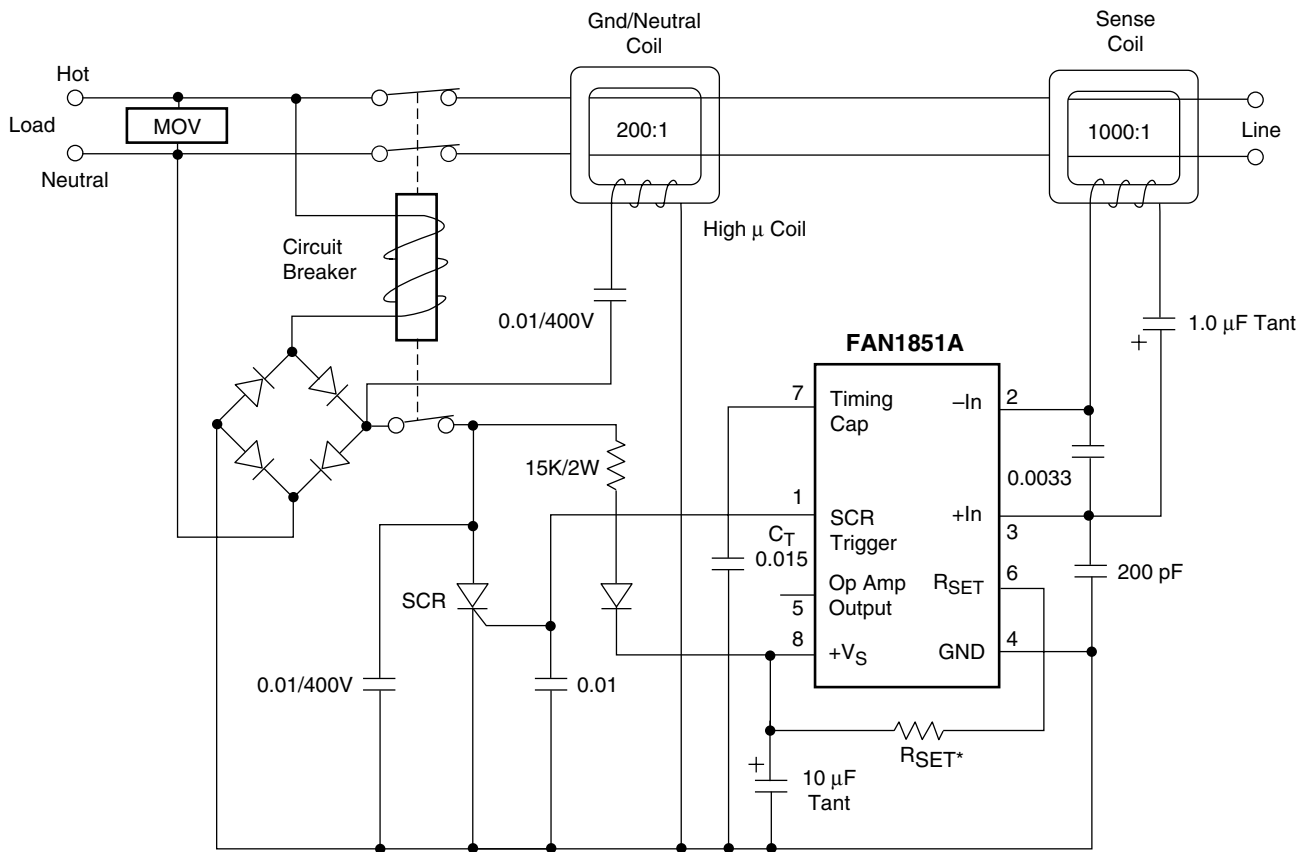

Figure 9. Normal Fault Sensitivity Test Circuit



*Adjust RSET for desired sensitivity.

Figure 10. 120 Hz Neutral Transformer Application

Mechanical Dimensions

8-Lead Plastic DIP Package

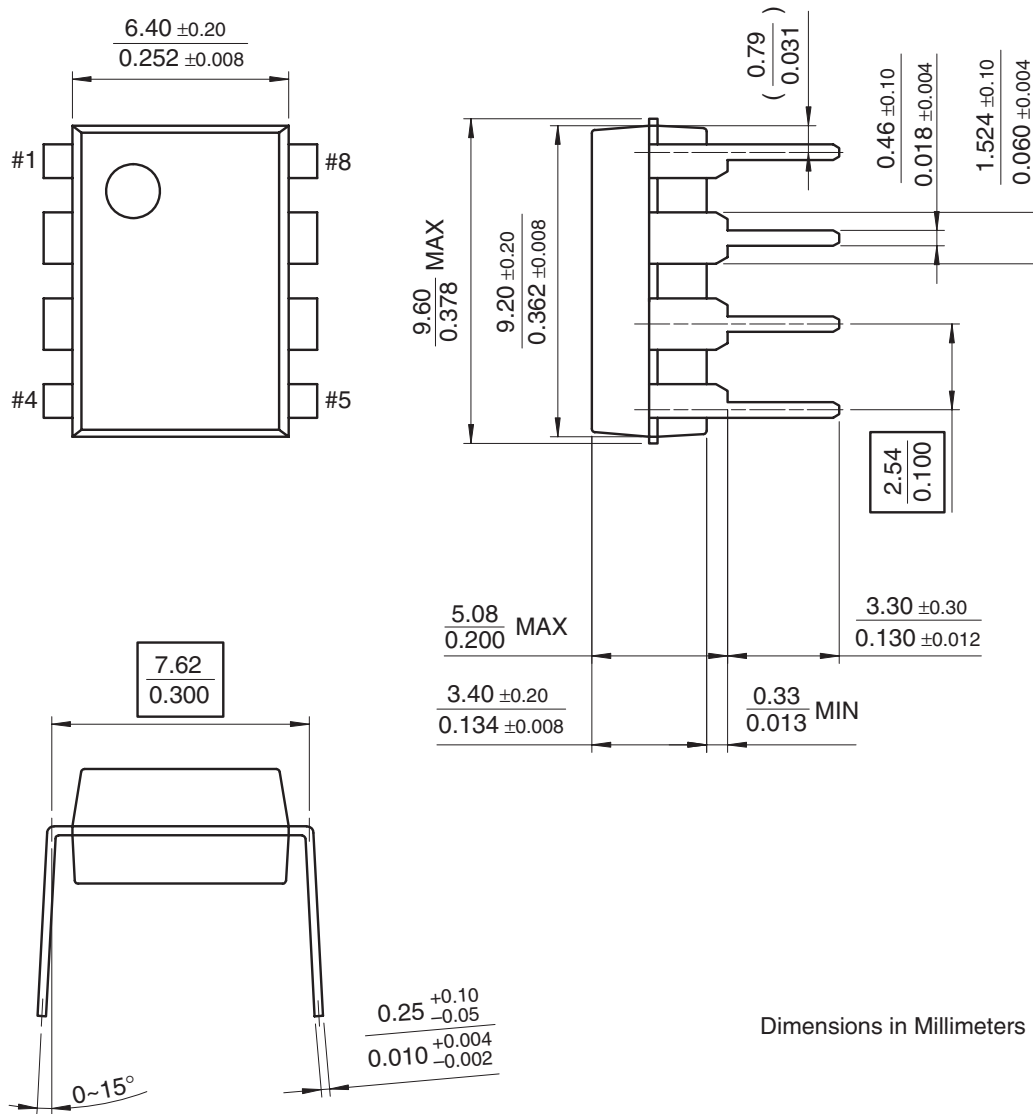

Dimensions in Millimeters

Mechanical Dimensions (continued)

8-Lead Plastic SOIC Package

Symbol	Inches		Millimeters		Notes
	Min.	Max.	Min.	Max.	
A	.053	.069	1.35	1.75	
A1	.004	.010	0.10	0.25	
B	.013	.020	0.33	0.51	
C	.008	.010	0.20	0.25	5
D	.189	.197	4.80	5.00	2
E	.150	.158	3.81	4.01	2
e	.050 BSC		1.27 BSC		
H	.228	.244	5.79	6.20	
h	.010	.020	0.25	0.50	
L	.016	.050	0.40	1.27	3
N	8		8		6
α	0°	8°	0°	8°	
ccc	—	.004	—	0.10	

Notes:

1. Dimensioning and tolerancing per ANSI Y14.5M-1982.
2. "D" and "E" do not include mold flash. Mold flash or protrusions shall not exceed .010 inch (0.25mm).
3. "L" is the length of terminal for soldering to a substrate.
4. Terminal numbers are shown for reference only.
5. "C" dimension does not include solder finish thickness.
6. Symbol "N" is the maximum number of terminals.

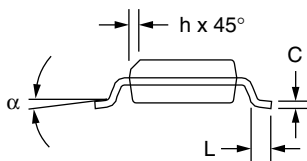
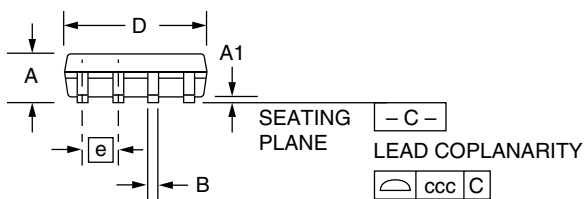
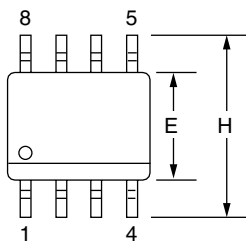

Ordering Information

Part Number	Package	Pb-Free	Operating Temperature Range	Packing Method
FAN1851AN	8-lead Plastic DIP	Yes	-40°C to +70°C	Rail
FAN1851AMX	8-lead Plastic SOIC	Yes	-40°C to +70°C	Tape and Reel

DISCLAIMER

FAIRCHILD SEMICONDUCTOR RESERVES THE RIGHT TO MAKE CHANGES WITHOUT FURTHER NOTICE TO ANY PRODUCTS HEREIN TO IMPROVE RELIABILITY, FUNCTION OR DESIGN. FAIRCHILD DOES NOT ASSUME ANY LIABILITY ARISING OUT OF THE APPLICATION OR USE OF ANY PRODUCT OR CIRCUIT DESCRIBED HEREIN; NEITHER DOES IT CONVEY ANY LICENSE UNDER ITS PATENT RIGHTS, NOR THE RIGHTS OF OTHERS.

LIFE SUPPORT POLICY

FAIRCHILD'S PRODUCTS ARE NOT AUTHORIZED FOR USE AS CRITICAL COMPONENTS IN LIFE SUPPORT DEVICES OR SYSTEMS WITHOUT THE EXPRESS WRITTEN APPROVAL OF THE PRESIDENT OF FAIRCHILD SEMICONDUCTOR CORPORATION. As used herein:

1. Life support devices or systems are devices or systems which, (a) are intended for surgical implant into the body, or (b) support or sustain life, and (c) whose failure to perform when properly used in accordance with instructions for use provided in the labeling, can be reasonably expected to result in a significant injury of the user.
2. A critical component in any component of a life support device or system whose failure to perform can be reasonably expected to cause the failure of the life support device or system, or to affect its safety or effectiveness.

www.fairchildsemi.com