

Summary

AccessTouch is an integrated combination key access controller featuring tough-sensitive keys for vandal-proof operation. An accompanying design blueprint is available for a complete low cost, access control product.

AccessTouch uses capacitive touch sensing technology. The PCB keyboard shown can be overlaid by a non-metallic covering. It automatically calculates signal averages to compensate for track capacitance, water splashes, etc. A buzzer output provides audio feedback as buttons are pressed.

AccessTouch is firmware for the PIC16F631 microcontroller and is available as a pre-programmed chip from electronics distributors or as a firmware download from www.hexwax.com.

User Operation

When the correct code is entered, the door release output is activated for a fixed time delay. The sequence of keys pressed prior to entering the code is unimportant.

To change the access code, an electrical switch is closed and the new code is entered twice. LEDs indicate 'Open', 'Closed' and 'Set Code' states. All LEDs turn off when the device enters a sleep state.

Features

- Tiny volume BOM cost
- Vandal-proof design, no parts need to be physically exposed
- Codes may be up to 8 digits
- Audio feedback on touch press
- Safe Controller mode available
- 20-pin SSOP package

Electrical Specifications

Table 1. Electrical Specifications	
Supply voltage Vdd	2.0 – 5.5 VDC
Current, sleep scan mode, 3V Vdd	~50µA
Operating Temperature	-40°C to 85°C



Typical Application Circuit

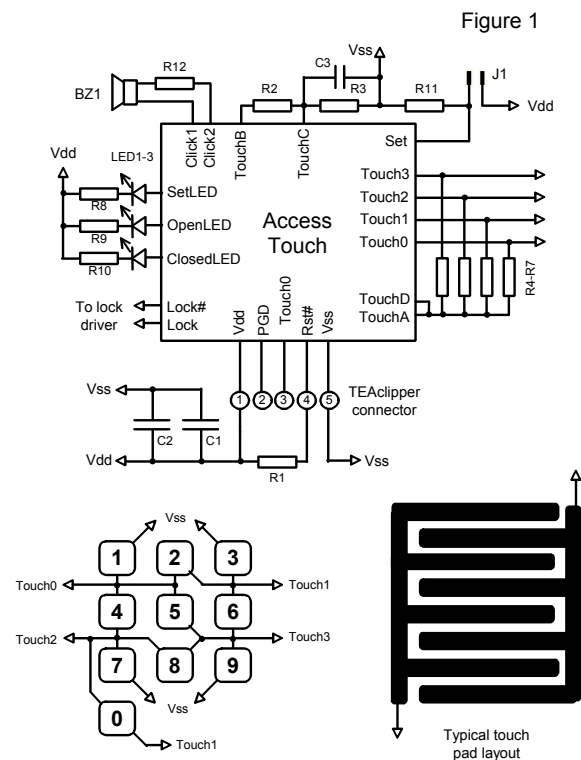

Device Pinout

Vdd	1	20	Vss
TouchD	2	19	PGD
Lock#	3	18	Touch3/PGC
RST#/Vpp	4	17	Lock
Click1	5	16	TouchC
TouchA	6	15	Touch1
Touch0	7	14	Touch2
SetLED	8	13	TouchB
ClosedLED	9	12	Click2
OpenLED	10	11	SetSw

Figure 2 - DIL / SSOP pinout

Name	Description
Click 1, 2	Buzzer driver
ClosedLED	'Closed' LED output
Rst# / Vpp	Reset input, active low / Vpp programming input
Lock	Lock release, active high
Lock#	Lock release, active low
OpenLED	'Open' LED output
PGD	PGD programming input
SetLED	'Set Code' LED output
SetSw	Set Code input control, active high
Touch0	Touch sensor input 0 (Keys 1, 2, 4, 5) PGC programming input
Touch1	Touch sensor input 1 (Keys 0, 2, 3, 6)
Touch2	Touch sensor input 2 (Keys 0, 4, 7, 8)
Touch3	Touch sensor input 3 (Keys 5, 6, 8, 9)
TouchA	Relaxation Oscillator Drive Output
TouchB	Relaxation Oscillator Reference Voltage Drive
TouchC	Relaxation Oscillator Reference Voltage Input
TouchD	Relaxation Oscillator Counter Input
Vdd	2.0V – 5.5V supply
Vss	Power supply ground

Bill of Materials

The Table 2 shows the recommended components for the bill of materials. The table does not include components for providing power or driving the lock release, which will be application specific. Package sizes apply to the gerber files in the product blueprint.

Label	Component
C1	100nF capacitor 0402
C2	1uF capacitor 0402
C3	1nF capacitor 0402
J1	Jumper or switch for 'set code' control
LED1-3	Light emitting diodes, e.g. HSMx-C265
R1	22k resistor 0402
R2	3k3 resistor 0402
R3	1k resistor 0402
R4-R7	120k resistor 0402
R8-R10	470R resistor 0402, adjust for LED brightness
R11	10k resistor 0402
R12	10k resistor 0402, adjust for buzzer volume
U1	PIC16F631-SS with AccessTouch preloaded
X1	Piezo buzzer, e.g. CMT-1603

How It Works

The touch pads measure the capacitance of the interleaved touch contacts using a relaxation oscillation

oscillator which scans the contacts in turn. When a finger is placed close to the contacts, the capacitance will increase, reducing the frequency of the oscillator. A sudden drop in capacitance is interpreted as a button press.

The touch pads measure changes in capacitance relative to a recent moving average. This provides some resilience to changes in humidity and water splashes. In order to achieve reliable operation, keys do not need to be pressed hard, but they must be held for approximately 250ms.

When power is applied, all three LEDs light for approximately 15 seconds while the average capacitance is initially measured.

After a period of inactivity, an optional sleep state reduces the key scan rate to once every 500ms. If this mode of operation is used, the first key must be held for this time in order to wake the device.

Vss, Vdd

Vss is the power supply ground reference. Vdd should be connected to a DC supply of 2.0V – 5.5V.

TouchA – Touch D

The TouchA to TouchD pins configure the relaxation oscillator and should be connected as shown in figure 1.

Touch1 – Touch4

The Touch1 to Touch4 pins are capacitance sense inputs. They should be connected to the touch pads as shown in figure 1.

Vpp, PGC, PCD

TEAclipper programming pins. Refer to the Delivery and Programming section for details. Note that the Vpp pin may be subject to voltages as high as 12V during programming.

RST#

The pin is an active low reset input. It is important that this is connected to a 22k pull-up to Vdd, the TEAclipper connector, and nothing else.

Open LED

Outputs high when the lock release is triggered. This pin can drive up to 25mA.

Closed LED

Outputs high when the lock release is not triggered and the device is not in a sleep state. This pin can drive up to 25mA.

Set Code LED

Outputs high when the SetSw input is high. This pin can drive up to 25mA.

SetSw

Set Code input control. Set to Vdd to enter a new code. The code must be entered twice and is acknowledged with a beep. This minimizes the chance of entering in an incorrect code while keeping user operation simple. It does mean, however, that codes made up of repetitive

sequences longer than the minimum code length cannot be specified, e.g. 12341234.

Typically the set switch will only be accessible from inside the secured-access area, or will be implemented as a key switch.

The code set by default is 123.

Lock, Lock#

The lock outputs control the access lock. These pins can drive up to 25mA, sufficient for a small relay.

Click1, Click2

Connect to a buzzer to provide audio feedback:

- High note: Button press registered
- Medium note: Code set
- Low note: Lock open

These pins can drive up to 25mA, so a current limiting series resistor may be required. This is the function of R12 in figure 1, which also serves as a volume control.

Touch Pad Design

The touch pads need to be designed for maximum capacitance when a finger is present, and minimum capacitance when not present. The design shown in figure 1 has been shown to be effective, with a track width of 1.1mm and gap of 0.33mm. The overall pad size should be at least 13mm square, with a minimum gap between pads of 5mm.

No physical contact is required and the touch pads may be overlaid with, for example, a label or thin acrylic panel. Alternatively, the pad may be placed in an inner PCB layer immediately below the exposed PCB surface.

Button presses are detected as a rise in capacitance in one or two sense lines. Too high a trigger sensitivity can be just as troublesome as low a trigger sensitivity. Therefore the sensitivity setting may require adjustment to suit a particular physical setup. (See nonvolatile settings section below.)

To avoid ambiguity, it is important that fingers do not induce capacitance where not wanted. Avoid unnecessary routing tracks on the exposed surface of the PCB. Apart from the touch pads, the circuit should avoid being placed where fingers might get close. Avoid metal enclosures.

Non-Volatile Settings

Various settings can be specified in the code memory at programming time (see the Programming AccessTouch section). Alternatively, they may be set in EEPROM memory at a later date using a PIC programmer. The EEPROM locations are shown in table 4.

Table 4. Nonvolatile Settings In EEPROM			
Address	Name	Default	Description
0x00	UseEE	0x00	Zero to use code memory settings, or non-zero for EEPROM settings
0x01	Sens	0x38	Touch trigger sensitivity
0x02	OpTime	0x08	Lock open time, 1/3s units
0x03	OpBeep	0x01	Zero for no beep on unlock

Table 4. Nonvolatile Settings In EEPROM			
Address	Name	Default	Description
0x04	WaitSlp	0x00	Wait time before entering sleep mode, or zero for no sleep, 1/15s units
0x05	MinLen	0x03	Minimum number of digits permitted in a new code.

Note that the access code is also stored in EEPROM and is visible to anybody with a PIC programmer.

Firmware Delivery on HexWax

If not bought as a pre-programmed chip, AccessTouch firmware is available as an encrypted firmware download from www.hexwax.com. To download it you will need a TEAclipper/PIC HV and a TEAclipper/USB adapter.

To load the firmware onto the TEAclipper, start the HexWax Explorer firmware and log in. Then download the AccessTouch firmware pack from the hexwax.com products section. When download completes, an AccessTouch folder will appear in the Local Files section of HexWax Explorer. In this folder is the *AccessTouch.wax* file that contains the firmware.

You will need AccessTouch license credits in order to decrypt the *AccessTouch.wax* file. Contact hexwax.com for details of payment options and how to obtain free samples.

Once you have license credits, select the *AccessTouch.wax* file and insert a TEAclipper/PIC HV into the TEAclipper/USB adapter. Press the *Charge Now...* button. Referring to figure 3, select how many licenses you wish to load onto the TEAclipper. Additionally, select the desired Non-Volatile Settings written into code memory as *MinLen-WaitSlp-OpBeep-OpTime-Sens* (refer to table 4). For example, for the default settings, enter 0300010838. Finally press OK to obtain a decryption key and to charge the TEAclipper with the decrypted firmware.

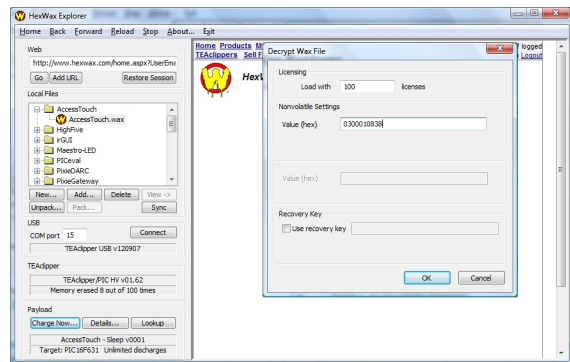

Figure 3: Decrypting the AccessTouch.wax file

Programming AccessTouch

AccessTouch is programmed into the microcontroller by inserting the TEAclipper into its connector. The circuit must be powered and the TEAclipper must be held in place until the LEDs stop flashing and the green LED glows steadily. The voltage V_{dd} during programming must be 4.5V – 5.5V.

Since the programming time is very fast, no programming socket is required for the TEAclipper. It may be leaned against five plate-through holes as depicted in figure 4.

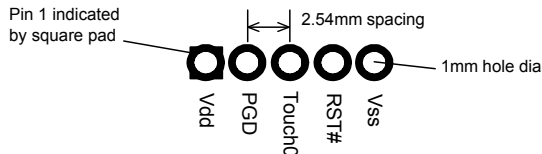

Figure 4. Recommended plate-through connector design

Evaluation Board

An evaluation board is available for AccessTouch consisting of a pre-assembled board containing all circuitry except the Set switch, lock driver and power source.

Product Blueprint

The evaluation board Gerber files and other construction information are available as a product blueprint in return for a signed Nondisclosure Agreement.

Alternate Options

AccessTouch can be reconfigured for alternate applications. For example:

- Combination Safe Controller
- Touch sensitive 12-key matrix keyboard replacement

Contact us for more information on these applications.

Author Contact



Firmware Factory Ltd
2 Marshall St, 3rd Floor
London W1F 9BB, UK
sales@firmwarefactory.com
support@firmwarefactory.com