

## NOTES

BUILT TO MEET THE REQUIREMENTS OF INDUSTRIAL AND COMMERCIAL USE. ALL METAL HOUSING—TOUGH EXTRUDED ALUMINUM CASE WITH BLACK POWDER-COATED STEEL COVER. HEAVY-DUTY CORD — 14/3 SJTW WIRE FOR EXTREME TEMPERATURE RANGES. INTEGRAL MOLDED PLUG AVAILABLE IN STRAIGHT-BLADE (NEMA 5-15P) OR TWIST-LOCK (NEMA L5-15P) CONFIGURATIONS. SEPARATE MOUNTING FEET WITH KEYHOLE SLOTS PROVIDE FOR WORK STATION MOUNTING IF DESIRED. COMES WITH LIGHTED ON/OFF SWITCH. INCLUDES 15A, 125VAC CIRCUIT BREAKER TO PREVENT ACCIDENTAL LINE OVERLOAD. CSA CERTIFIED, UL 1363 LISTED.

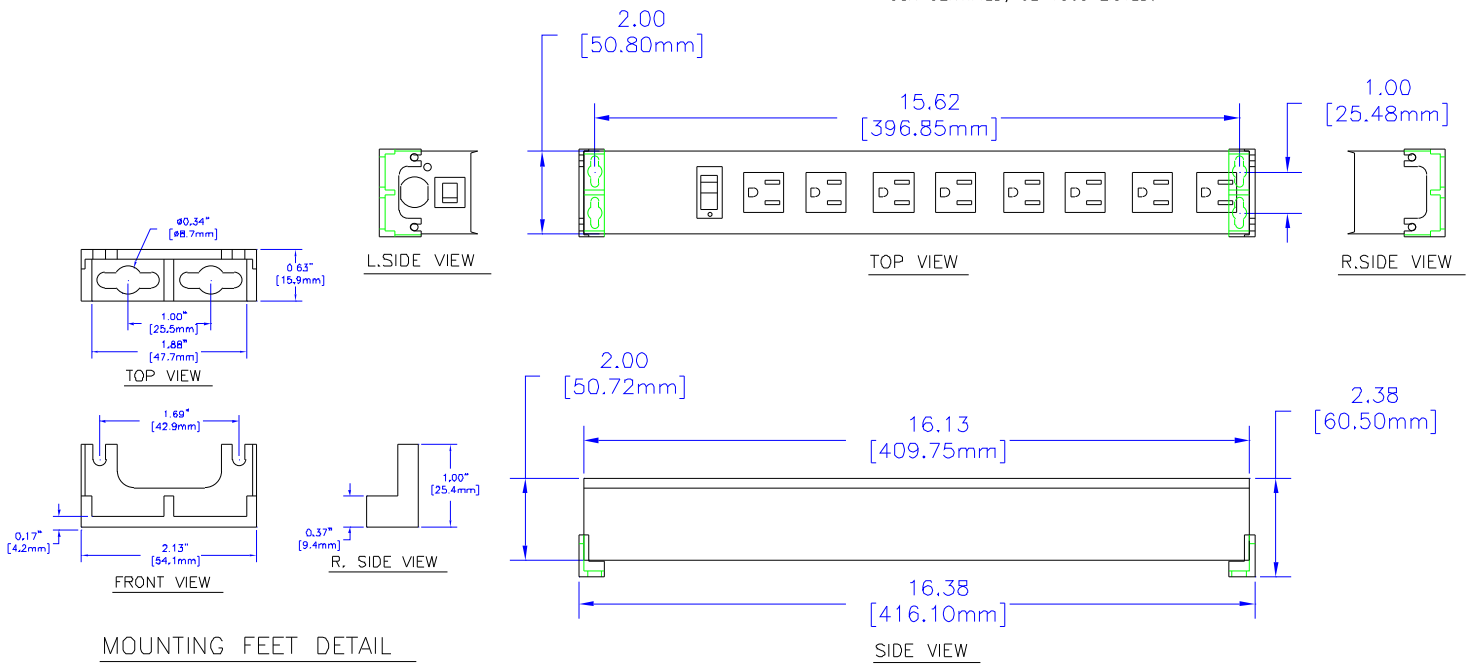

\*SEE CATALOG FOR THE COMPLETE PART NUMBER BASED ON THE OPTIONS LISTED IN THE NOTE SECTION

UNLESS OTHERWISE SPECIFIED  
 DIMENSIONS ARE IN INCHES  
 F +/- .02  
 XX +/- .02  
 XXX +/- .015  
 SURF +/- .005  
 ANGLES +/- .5 DEG

NOTICE  
 HAMMOND CANNOT BE HELD RESPONSIBLE TO THE USER OR HIS OR HER FOR ANY DAMAGE OR INJURY TO PERSONS OR PROPERTY CAUSED BY THE USE OF ANY PRODUCT MANUFACTURED BY HAMMOND MANUFACTURING COMPANY.



WEB: [WWW.HAMMONDMFG.COM](http://WWW.HAMMONDMFG.COM)

TITLE: HAMMOND INDUSTRIAL GRADE POWER STRIPS  
 DRAWN BY: MJM DATE: 02/09/01  
 SCALE: PAGE: 1 OF 1  
 PART NUMBER: 1584H8\*\*\*