



PHOTOCOUPLER

PS8601, PS8601L

HIGH SPEED ANALOG OUTPUT TYPE 8-PIN PHOTOCOUPLER

–NEPOC Series–

DESCRIPTION

The PS8601 and PS8601L are 8-pin high speed photocouplers containing a GaAlAs LED on input side and a PN photodiode and a high speed amplifier transistor on output side on one chip. The PS8601 is in a plastic DIP (Dual In-line Package). The PS8601L is lead bending type (Gull wing) for surface mount.

FEATURES

- High supply voltage ($V_{CC} = 35 \text{ V MAX.}$)
- High speed response ($t_{PHL}, t_{PLH} = 0.8 \mu\text{S MAX.}$)
- High isolation voltage ($BV = 5\,000 \text{ V}_{r.m.s.}$)
- TTL, CMOS compatible with a resistor
- For Infrared reflow soldering
- Ordering number of tape product: PS8601L-E3, E4: 1 000 pcs/reel
- Safety standards
 - UL approved: File No. E72422 (S)
 - BSI approved: No. 8004
 - VDE0884 approved (Option) No.91877

APPLICATIONS

- Interface for measurement or control equipment
- Substitutions for relays and pulse transformers

The information in this document is subject to change without notice. Before using this document, please confirm that this is the latest version.

★ PACKAGE DIMENSIONS (UNIT: mm)

DIP Type

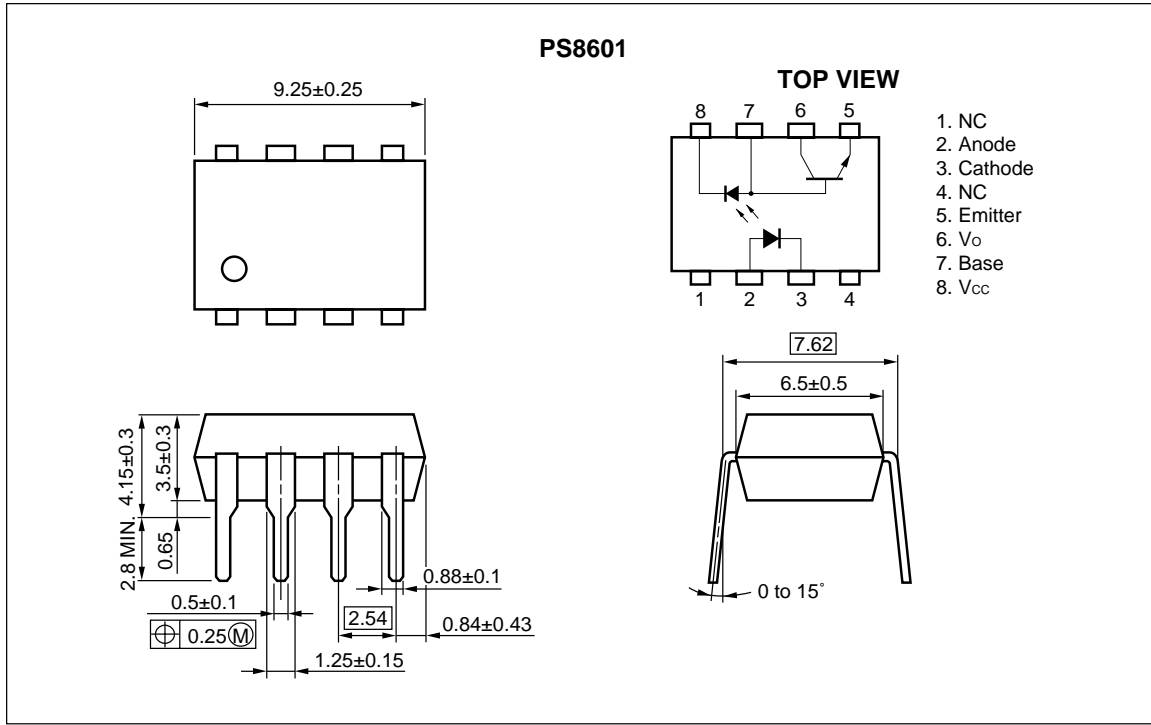

Lead Bending Type

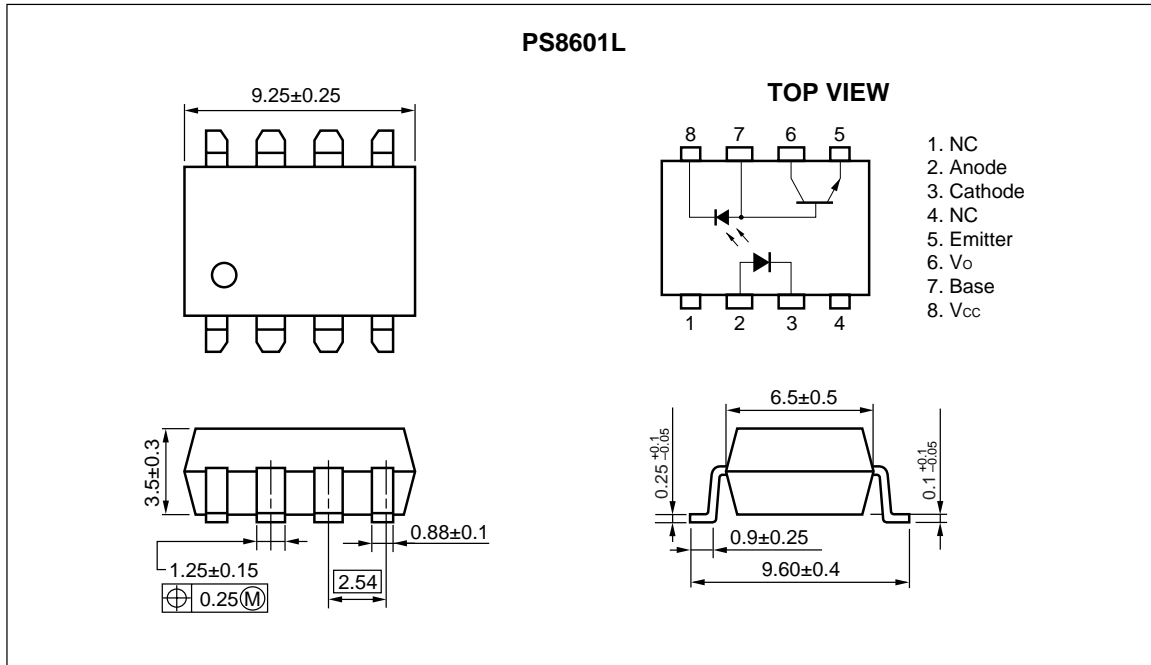

★ Lead Bending Type For Long Creepage Distance

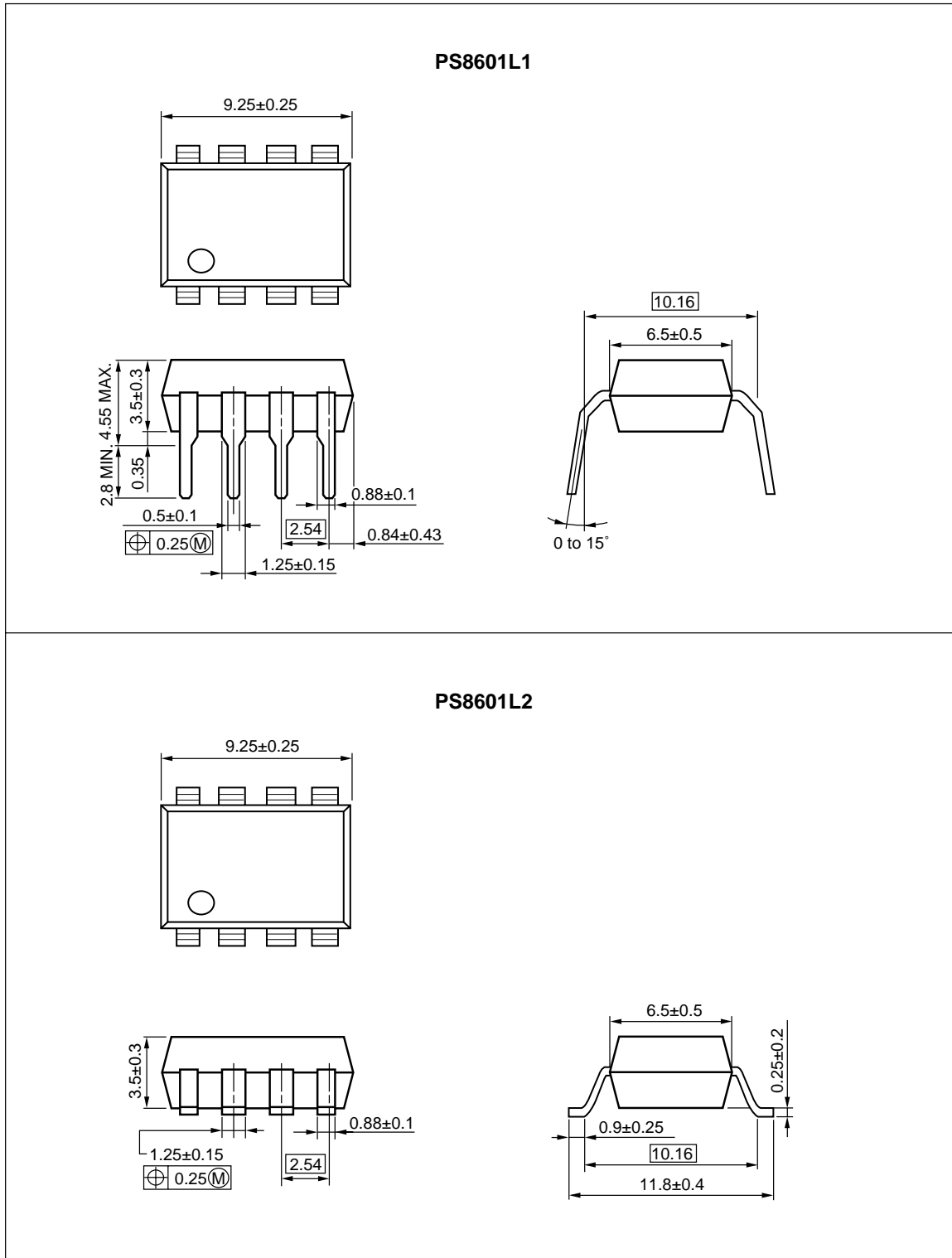

MARKING EXAMPLE

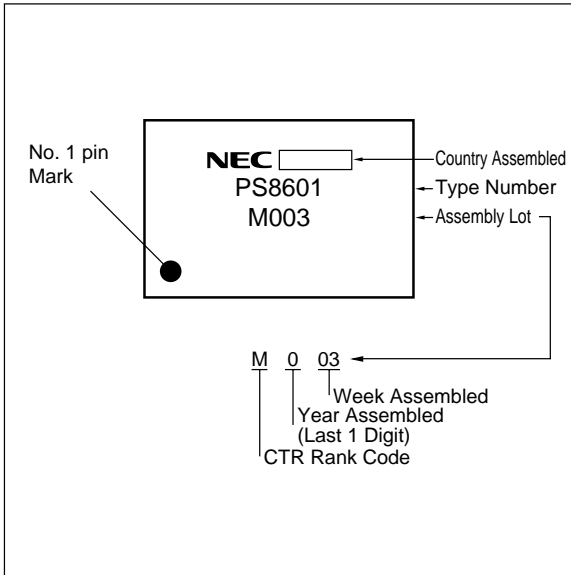

ORDERING INFORMATION (Solder Contains Lead)

Part Number	Package	Packing Style	Application Part Number ^{*1}	
PS8601	8-pin DIP	Magazine case 50 pcs	PS8601	
PS8601L			PS8601L	
PS8601L1				
PS8601L2				
PS8601L-E3		Embossed Tape 1 000 pcs/reel	PS8601	
PS8601L-E4				
PS8601-V		Magazine case 50 pcs		PS8601
PS8601L-V				PS8601L
PS8601L1-V				
PS8601L2-V				
PS8601L-V-E3		Embossed Tape 1 000 pcs/reel		PS8601
PS8601L-V-E4				

*1 For the application of the Safety Standard, following part number should be used.

ORDERING INFORMATION (Pb-Free)

Part Number	Package	Packing Style	Application Part Number ^{*1}	
PS8601-A	8-pin DIP	Magazine case 50 pcs	PS8601	
PS8601L-A			PS8601L	
PS8601L1-A				
PS8601L2-A				
PS8601L-E3-A		Embossed Tape 1 000 pcs/reel		
PS8601L-E4-A				
PS8601-V-A		Magazine case 50 pcs	PS8601	
PS8601L-V-A				PS8601L
PS8601L1-V-A				
PS8601L2-V-A				
PS8601L-V-E3-A			Embossed Tape 1 000 pcs/reel	
PS8601L-V-E4-A				

*1 For the application of the Safety Standard, following part number should be used.

ABSOLUTE MAXIMUM RATINGS (T_A = 25 °C, unless otherwise specified)

Parameter		Symbol	Ratings	Unit
Diode	Forward Current	I _F	25	mA
	Reverse Voltage	V _R	5	V
	Power Dissipation	P _D	45	mW
Detector	Supply Voltage	V _{CC}	35	V
	Output Voltage	V _O	35	V
	Output Current	I _O	8	mA
	Power Dissipation	P _C	100	mW
Isolation Voltage ^{*1}		BV	5 000	Vr.m.s.
Operating Ambient Temperature		T _A	-55 to +100	°C
Storage Temperature		T _{stg}	-55 to +100	°C

*1 AC voltage for 1 minute at T_A = 25 °C, RH = 60 % between input and output.

ELECTRICAL CHARACTERISTICS (T_A = 25 °C)

Parameter		Symbol	Conditions	MIN.	TYP.*1	MAX.	Unit
Diode	Forward Voltage	V _F	I _F = 16 mA		1.7	2.2	V
	Reverse Current	I _R	V _R = 5 V			10	μA
	Forward Voltage Temperature Coefficient	ΔV _F /ΔT	I _F = 16 mA		-1.6		mV/°C
	Terminal Capacitance	C _t	V = 0 V, f = 1 MHz		60		pF
Detector	High Level Output Current	I _{OH} (1)	I _F = 0 mA, V _{CC} = V _O = 5.5 V		3	500	nA
	High Level Output Current	I _{OH} (2)	I _F = 0 mA, V _{CC} = V _O = 35 V			100	μA
	Low Level Output Voltage	V _{OL}	I _F = 16 mA, V _{CC} = 4.5 V, I _O = 1.2 mA		0.1	0.4	V
	Low Level Supply Current	I _{CCL}	I _F = 16 mA, V _O = Open, V _{CC} = 35 V		50		μA
	High Level Supply Current	I _{CCH}	I _F = 0 mA, V _O = Open, V _{CC} = 35 V		0.01	1	μA
	DC Current Gain	h _{FE}	V _O = 5 V, I _O = 3 mA		100		
Coupled	Current Transfer Ratio	CTR	I _F = 16 mA, V _{CC} = 4.5 V, V _O = 0.4 V	15			%
	Isolation Resistance	R _{I-O}	V _{I-O} = 1 kV _{DC}	10 ¹¹			Ω
	Isolation Capacitance	C _{I-O}	V = 0 V, f = 1 MHz		0.7		pF
	Propagation Delay Time (H → L) ^{*2}	t _{PHL}	I _F = 16 mA, V _{CC} = 5 V, R _L = 1.9 kΩ		0.5	0.8	μs
	Propagation Delay Time (L → H) ^{*2}	t _{PLH}	I _F = 16 mA, V _{CC} = 5 V, R _L = 1.9 kΩ		0.3	0.8	μs

*1 Typical values at T_A = 25 °C

*2 Test circuit for propagation delay time

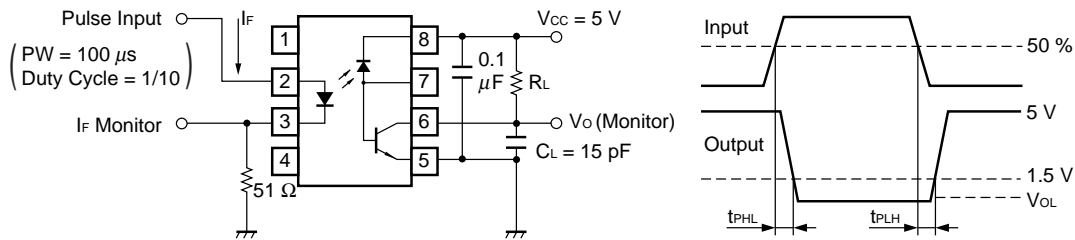

C_L includes probe and stray wiring capacitance

USAGE CAUTIONS

1. This product is weak for static electricity by designed with high-speed integrated circuit so protect against static electricity when handling.
2. By-pass capacitor of more than 0.1 μF is used between V_{CC} and GND near device. Also, ensure that the distance between the leads of the photocoupler and capacitor is no more than 10 mm.
- ★ 3. Avoid storage at a high temperature and high humidity.

TYPICAL CHARACTERISTICS ($T_A = 25^\circ\text{C}$, unless otherwise specified)

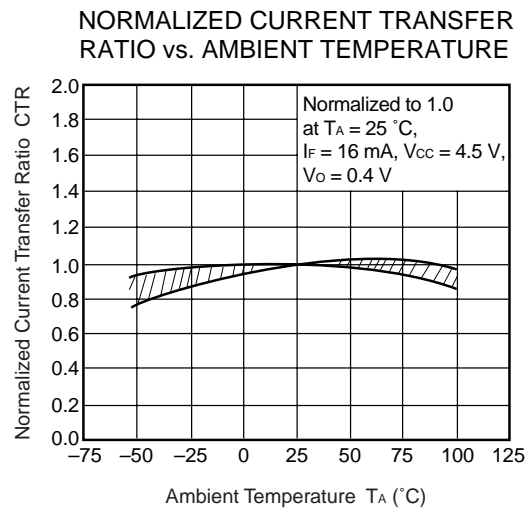
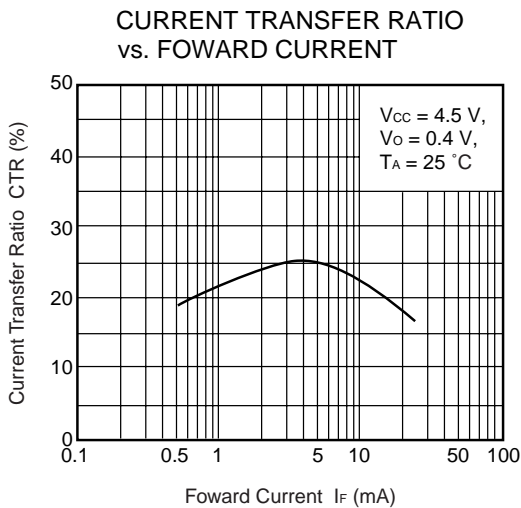
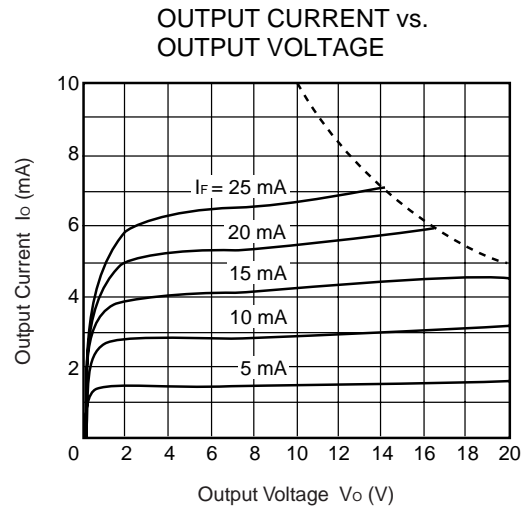
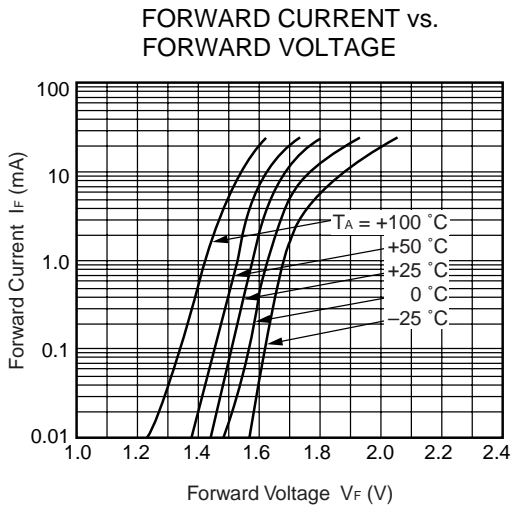
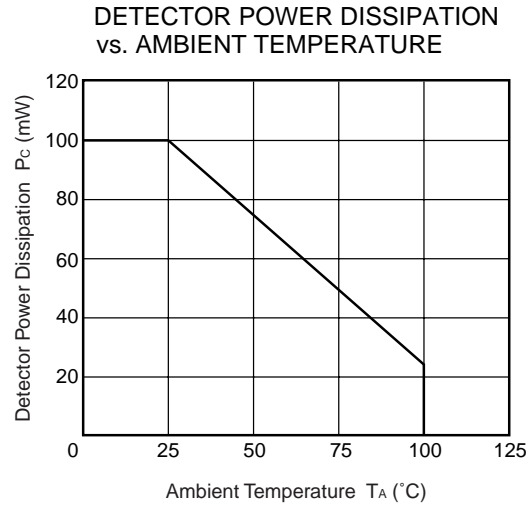
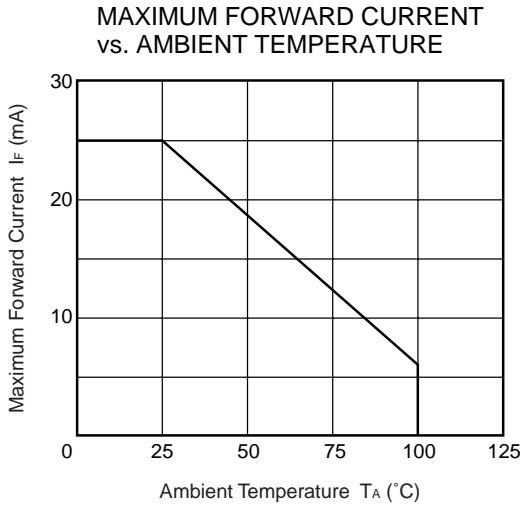

OUTPUT VOLTAGE vs. FOWARD CURRENT

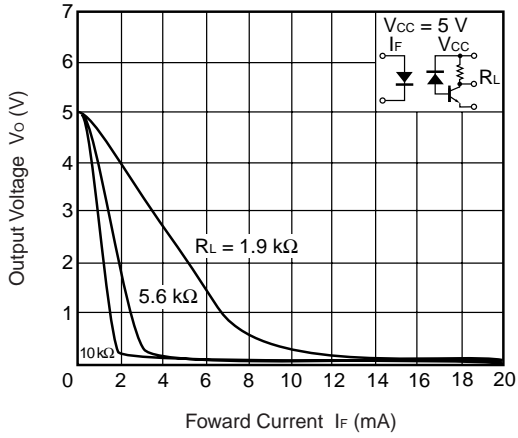

HIGH LEVEL OUTPUT CURRENT vs. AMBIENT TEMPERATURE

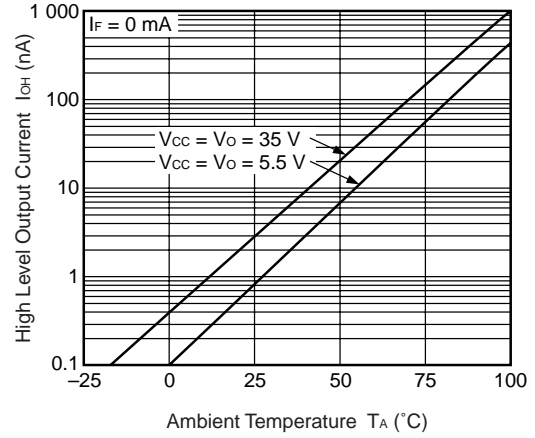

PROPAGATION DELAY TIME, vs. LORD RESISTANCE

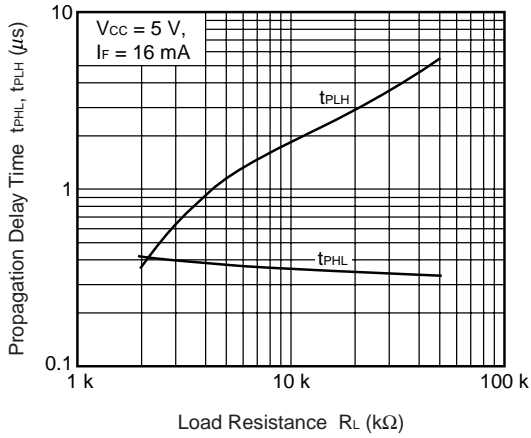

PROPAGATION DELAY TIME, vs. AMBIENT TEMPERATURE

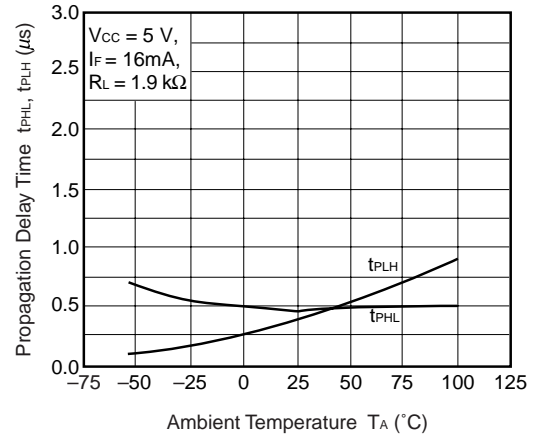

Remark The graphs indicate nominal characteristics.

★ TAPING SPECIFICATIONS (UNIT: mm)

Outline and Dimensions (Tape)

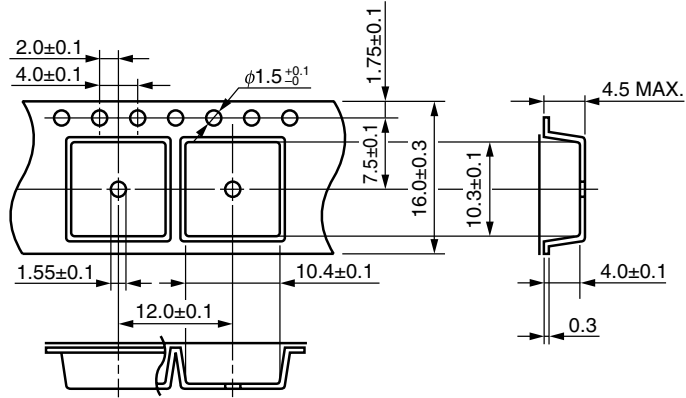

Tape Direction

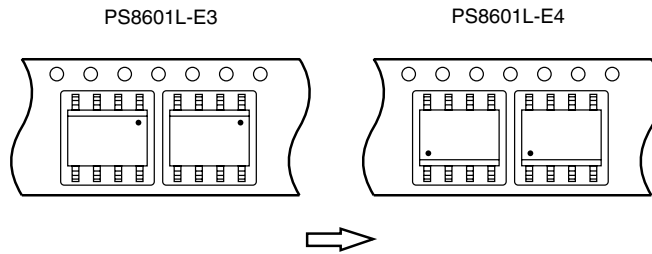

Outline and Dimensions (Reel)

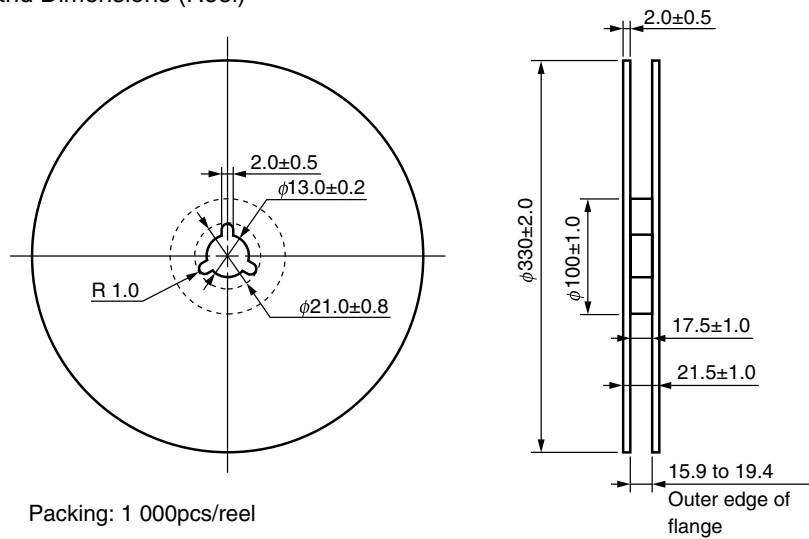

Packing: 1 000pcs/reel

★ NOTES ON HANDLING

1. Recommended soldering conditions

(1) Infrared reflow soldering

- Peak reflow temperature 260°C or below (package surface temperature)
- Time of peak reflow temperature 10 seconds or less
- Time of temperature higher than 220°C 60 seconds or less
- Time to preheat temperature from 120 to 180°C 120±30 s
- Number of reflows Three
- Flux Rosin flux containing small amount of chlorine (The flux with a maximum chlorine content of 0.2 Wt% is recommended.)

Recommended Temperature Profile of Infrared Reflow

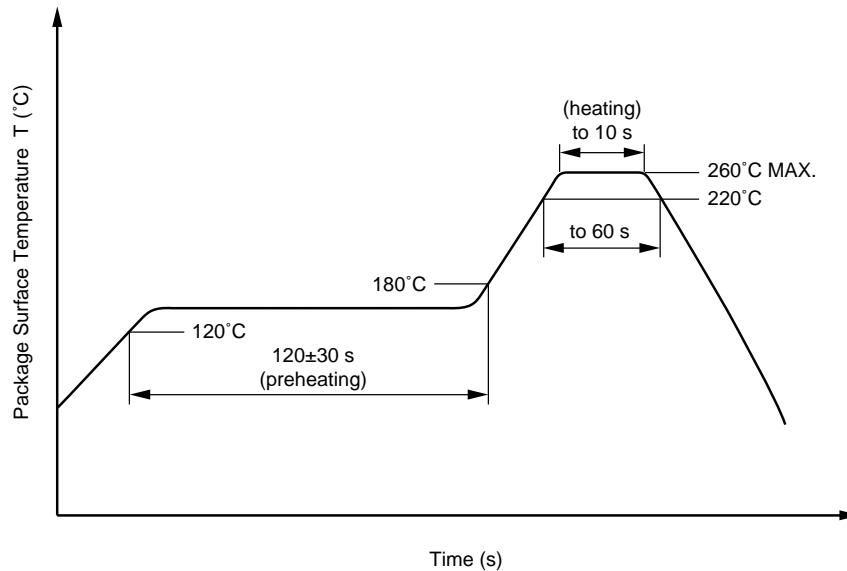

(2) Wave soldering

- Temperature 260°C or below (molten solder temperature)
- Time 10 seconds or less
- Preheating conditions 120°C or below (package surface temperature)
- Number of times One (Allowed to be dipped in solder including plastic mold portion.)
- Flux Rosin flux containing small amount of chlorine (The flux with a maximum chlorine content of 0.2 Wt% is recommended.)

(3) Cautions

- Fluxes Avoid removing the residual flux with freon-based and chlorine-based cleaning solvent.

2. Cautions regarding noise

Be aware that when voltage is applied suddenly between the photocoupler's input and output or between collector-emitters at startup, the output side may enter the on state, even if the voltage is within the absolute maximum ratings.

SPECIFICATION OF VDE MARKS LICENSE DOCUMENT (VDE0884)

Parameter	Symbol	Speck	Unit
Application classification (DIN VDE 0109) for rated line voltages $\leq 300 V_{r.m.s.}$ for rated line voltages $\leq 600 V_{r.m.s.}$		IV III	
Climatic test class (DIN IEC 68 Teil 1/09.80)		55/100/21	
Dielectric strength maximum operating isolation voltage Test voltage (partial discharge test, procedure a for type test and random test) $U_{pr} = 1.2 \times U_{IORM}, P_d < 5 \text{ pC}$	U_{IORM} U_{pr}	890 1 068	V_{peak} V_{peak}
★ Test voltage (partial discharge test, procedure b for all devices test) $U_{pr} = 1.6 \times U_{IORM}, P_d < 5 \text{ pC}$	U_{pr}	1 424	V_{peak}
Highest permissible overvoltage	U_{TR}	8 000	V_{peak}
Degree of pollution (DIN VDE 0109)		2	
Clearance distance		> 7.0	mm
Creepage distance		> 7.0	mm
Comparative tracking index (DIN IEC 112/VDE 0303 part 1)	CTI	175	
Material group (DIN VDE 0109)		III a	
Storage temperature range	T_{stg}	-55 to +150	°C
Operating temperature range	T_A	-55 to +100	°C
Isolation resistance, minimum value $V_{IO} = 500 \text{ V dc at } T_A = 25 \text{ °C}$ $V_{IO} = 500 \text{ V dc at } T_A \text{ MAX. at least } 100 \text{ °C}$	Ris MIN. Ris MIN.	10^{12} 10^{11}	Ω Ω
Safety maximum ratings (maximum permissible in case of fault, see thermal derating curve) Package temperature Current (input current I_F , $P_{Si} = 0$) Power (output or total power dissipation) Isolation resistance $V_{IO} = 500 \text{ V dc at } T_A = 175 \text{ °C (Tsi)}$	Tsi Isi Psi Ris MIN.	175 400 700 10^9	°C mA mW Ω

Subject: Compliance with EU Directives

CEL certifies, to its knowledge, that semiconductor and laser products detailed below are compliant with the requirements of European Union (EU) Directive 2002/95/EC Restriction on Use of Hazardous Substances in electrical and electronic equipment (RoHS) and the requirements of EU Directive 2003/11/EC Restriction on Penta and Octa BDE.

CEL Pb-free products have the same base part number with a suffix added. The suffix –A indicates that the device is Pb-free. The –AZ suffix is used to designate devices containing Pb which are exempted from the requirement of RoHS directive (*). In all cases the devices have Pb-free terminals. All devices with these suffixes meet the requirements of the RoHS directive.

This status is based on CEL’s understanding of the EU Directives and knowledge of the materials that go into its products as of the date of disclosure of this information.

Restricted Substance per RoHS	Concentration Limit per RoHS (values are not yet fixed)	Concentration contained in CEL devices	
		-A	-AZ
Lead (Pb)	< 1000 PPM	Not Detected	(*)
Mercury	< 1000 PPM	Not Detected	
Cadmium	< 100 PPM	Not Detected	
Hexavalent Chromium	< 1000 PPM	Not Detected	
PBB	< 1000 PPM	Not Detected	
PBDE	< 1000 PPM	Not Detected	

If you should have any additional questions regarding our devices and compliance to environmental standards, please do not hesitate to contact your local representative.

Important Information and Disclaimer: Information provided by CEL on its website or in other communications concerning the substance content of its products represents knowledge and belief as of the date that it is provided. CEL bases its knowledge and belief on information provided by third parties and makes no representation or warranty as to the accuracy of such information. Efforts are underway to better integrate information from third parties. CEL has taken and continues to take reasonable steps to provide representative and accurate information but may not have conducted destructive testing or chemical analysis on incoming materials and chemicals. CEL and CEL suppliers consider certain information to be proprietary, and thus CAS numbers and other limited information may not be available for release.

In no event shall CEL’s liability arising out of such information exceed the total purchase price of the CEL part(s) at issue sold by CEL to customer on an annual basis.

See CEL Terms and Conditions for additional clarification of warranties and liability.