

FEATURES

- **HIGH ISOLATION VOLTAGE**
BV: 3.75 k Vr.m.s. MIN
- **SOP (SMALL OUT-LINE PACKAGE)**
- **ISOLATED CHANNELS PER EACH PACKAGE**
- **HIGH SPEED SWITCHING**
 $t_r = 3 \mu s$, $t_f = 5 \mu s$ TYP
- **LOW COLLECTOR DARK CURRENT**
 $I_{CEO} = 5 \text{ nA}$ TYP @ $T_A = 25 \text{ }^\circ\text{C}$, $V_{CE} = 40 \text{ V}$
- **TAPE AND REEL AVAILABLE**

DESCRIPTION

PS2701-1, -2, and -4 are optically coupled isolators containing a GaAs light emitting diode and a NPN silicon phototransistor. Each is mounted in a plastic SOP (Small Outline Package) for high density applications. This package has a shield effect to cut off ambient light.

APPLICATIONS

Interface circuit for various instrumentations and control equipment.

- **AC LINE/DIGITAL LOGIC**
- **DIGITAL LOGIC INTERFACE**
- **TWISTED PAIR LINE RECEIVER**
- **TELEPHONE/TELEGRAPH LINE RECEIVER**
- **HIGH FREQUENCY POWER SUPPLY FEEDBACK CONTROL**
- **RELAY CONTACT MONITOR**
- **POWER SUPPLY MONITOR**

ELECTRICAL CHARACTERISTICS ($T_A = 25^\circ\text{C}$)

PART NUMBER			PS2701-1, -2, -4		
SYMBOLS	PARAMETERS	UNITS	MIN	TYP	MAX
Diode	V_F	Forward Voltage, $I_F = 5 \text{ mA}$	V	1.1	1.4
	I_R	Reverse Current, $V_R = 5 \text{ V}$	μA		5
	C	Junction Capacitance, $V = 0$, $f = 1.0 \text{ MHz}$	pF		30
Transistor	I_{CEO}	Collector to Emitter Dark Current, $V_{CE} = 40 \text{ V}$, $I_F = 0$	nA		100
Coupled	CTR	Current Transfer Ratio ¹ , $I_F = 5 \text{ mA}$, $V_{CE} = 5 \text{ V}$	%	50	300
	$V_{CE(sat)}$	Collector Saturation Voltage, $I_F = 10 \text{ mA}$, $I_C = 2 \text{ mA}$	V		0.3
	R1-2	Isolation Resistance, $V_{IN-OUT} = 1.0 \text{ k Vdc}$	Ω	10^{11}	
	C1-2	Isolation Capacitance, $V = 0$, $f = 1.0 \text{ MHz}$	pF		0.4
	t_r	Rise Time ² , $V_{CC} = 5 \text{ V}$, $I_C = 2 \text{ mA}$, $R_L = 100 \Omega$	μs		3
t_f	Fall Time ² , $V_{CC} = 5 \text{ V}$, $I_C = 2 \text{ mA}$, $R_L = 100 \Omega$	μs		5	

Notes:

1. CTR rank (PS2701-1 only)
L: 100 to 300 %
M: 50 to 150 %

2. Test Circuit for Switching Time

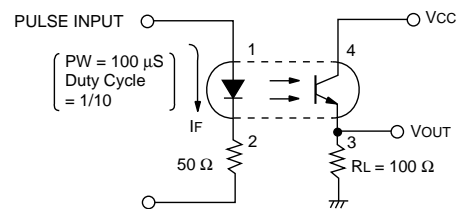
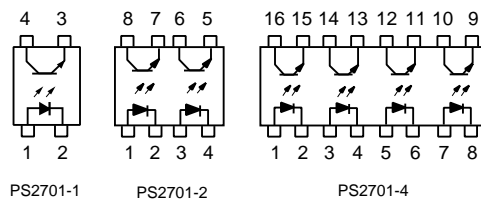

ABSOLUTE MAXIMUM RATINGS¹ (T_A = 25°C)

SYMBOLS	PARAMETERS	UNITS	RATINGS	
			PS2701-1	PS2701-2, -4
Diode				
I _F	Forward Current (DC)	mA	50	50
V _R	Reverse Voltage	V	6	6
P _D	Power Dissipation	mW/Ch	80	80
I _F (PEAK)	Peak Forward Current (P _W = 100 μs, Duty Cycle 1%)	A	1	1
Transistor				
V _{CEO}	Collector to Emitter Voltage (I _C = 1mA, I _B = 0)	V	40	40
V _{ECO}	Emitter to Collector Voltage (I _E = 100μA, I _B = 0)	V	6	6
I _C	Collector Current	mA/Ch	80	80
P _C	Power Dissipation	mW/Ch	150	120
Coupled				
BV	Isolation Voltage ²	V _{r.m.s.}	3750	3750
T _{STG}	Storage Temperature	°C	-55 to +150	
T _{OPT}	Operating Temperature	°C	-55 to +100	

Notes:

1. Operation in excess of any one of these parameters may result in permanent damage.
2. AC voltage for 1 minute at T_A = 25 °C, RH = 60 % between input and output.

TYPICAL PERFORMANCE CURVES (T_A = 25 °C)

DIODE POWER DISSIPATION vs. AMBIENT TEMPERATURE

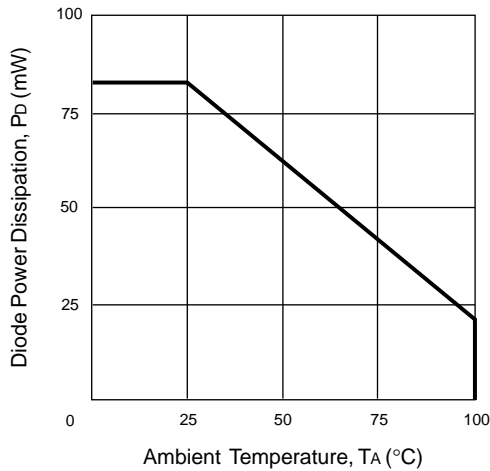

TRANSISTOR POWER DISSIPATION vs. AMBIENT TEMPERATURE

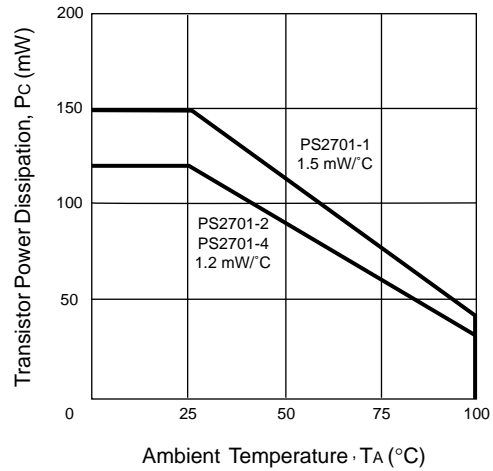

FORWARD CURRENT vs. FORWARD VOLTAGE

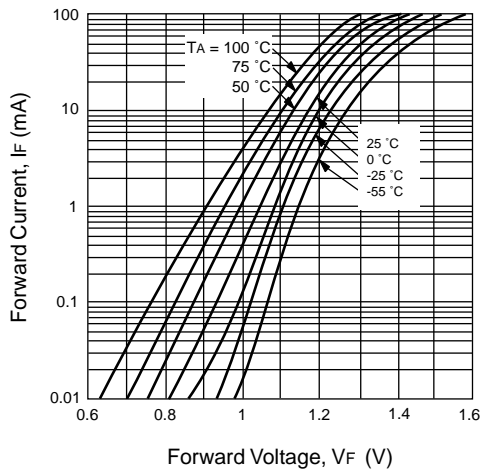

COLLECTOR CURRENT vs. COLLECTOR TO EMITTER VOLTAGE

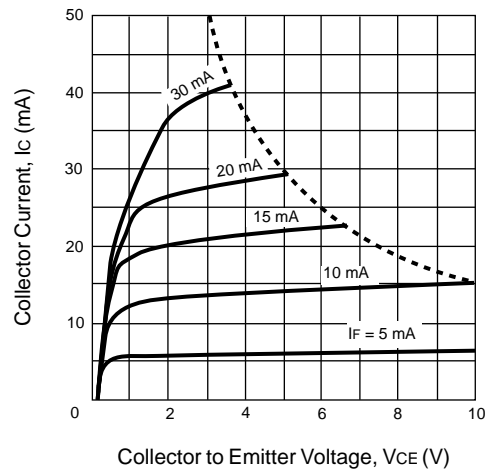

TYPICAL PERFORMANCE CURVES ($T_A = 25\text{ }^\circ\text{C}$)

COLLECTOR TO EMITTER DARK CURRENT vs. AMBIENT TEMPERATURE

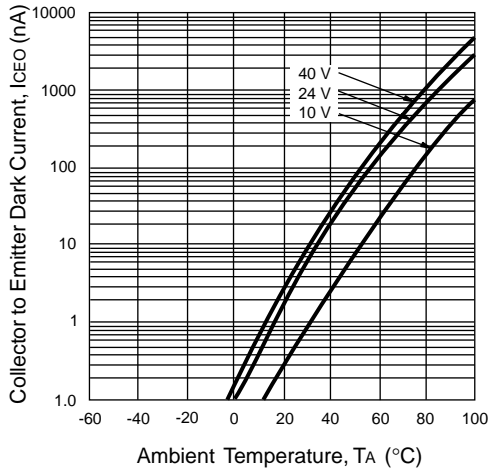

COLLECTOR CURRENT vs. COLLECTOR SATURATION VOLTAGE

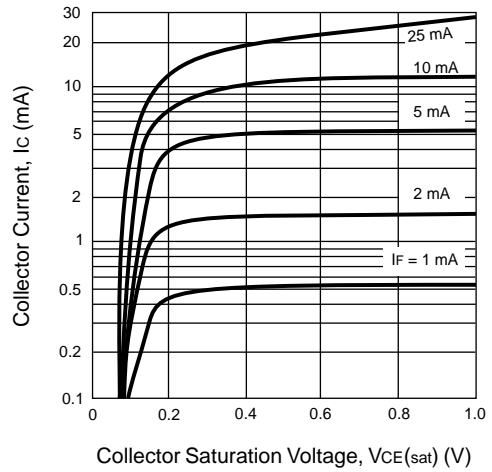

NORMALIZED OUTPUT CURRENT vs. AMBIENT TEMPERATURE

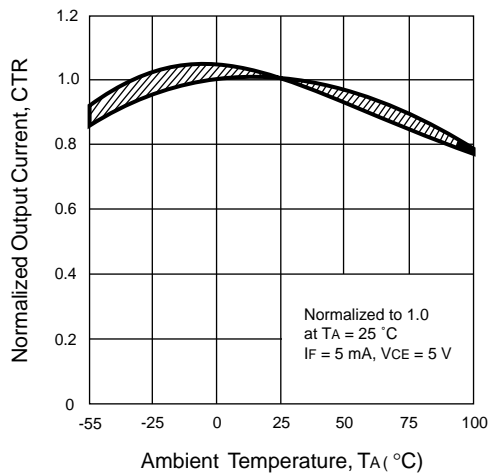

CURRENT TRANSFER RATIO vs. FORWARD CURRENT

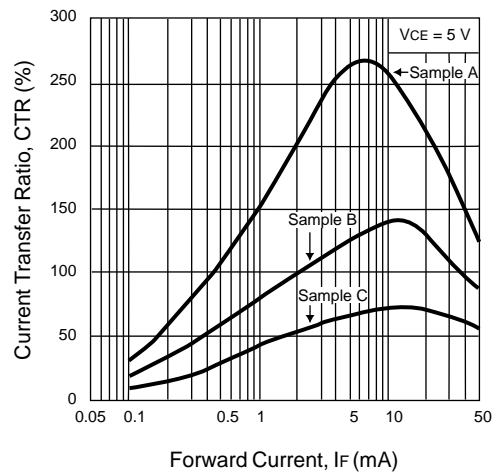

SWITCHING TIME vs. LOAD RESISTANCE

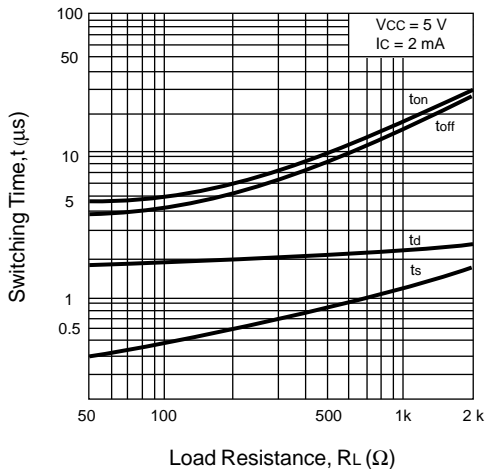

FREQUENCY RESPONSE

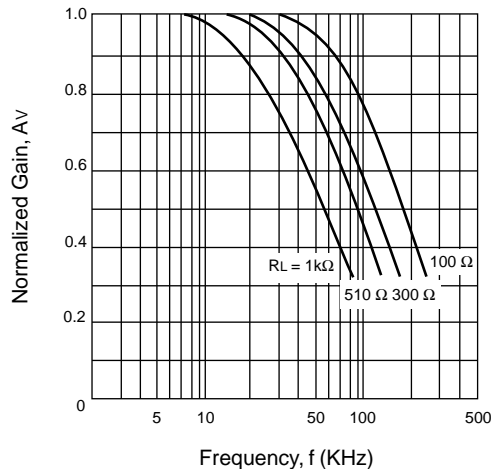

TYPICAL PERFORMANCE CURVES (TA = 25 °C)

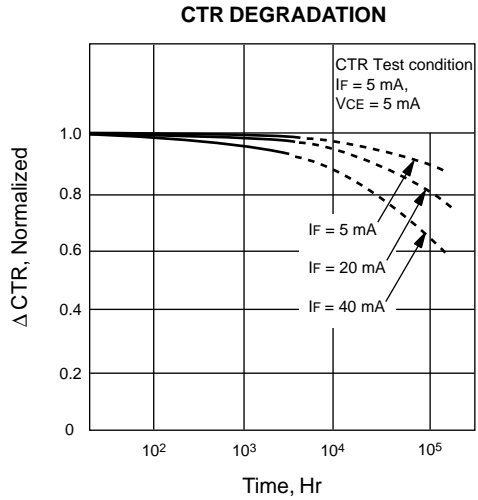
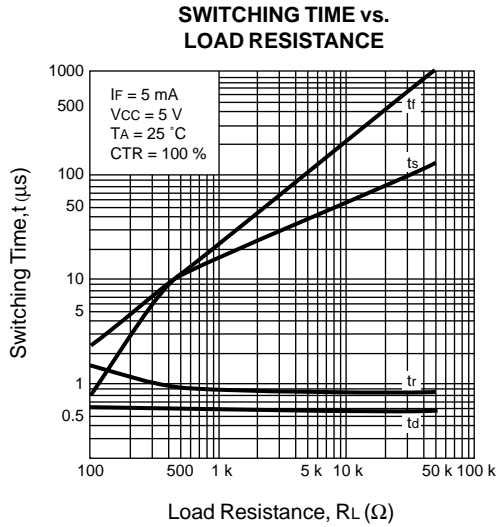

OUTLINE DIMENSIONS (Units in mm)

PS2701-1

PIN CONNECTION (Top View)

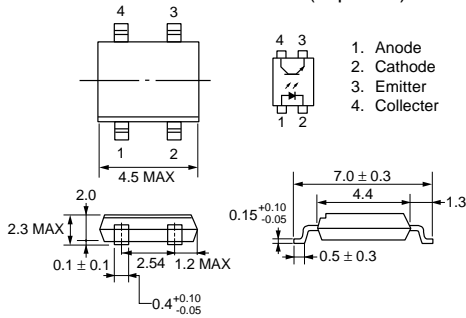

PS2701-2

PIN CONNECTION (Top View)

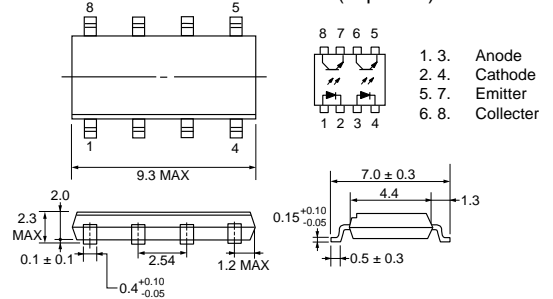

PS2701-4

PIN CONNECTION (Top View)

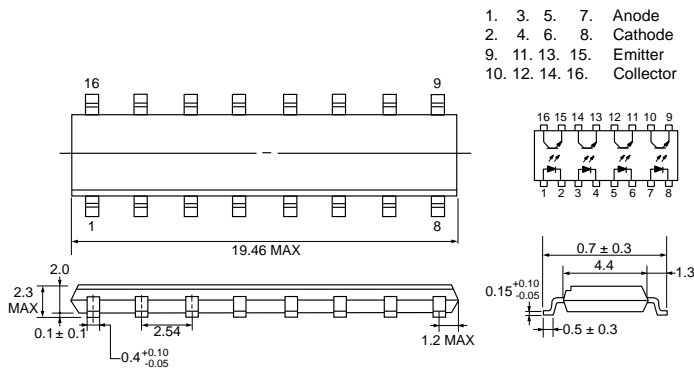

EXCLUSIVE NORTH AMERICAN AGENT FOR **NEC** RF, MICROWAVE & OPTOELECTRONIC SEMICONDUCTORS

CEL CALIFORNIA EASTERN LABORATORIES • Headquarters • 4590 Patrick Henry Drive • Santa Clara, CA 95054-1817 • (408) 988-3500 • Telex 34-6393 • FAX (408) 988-0279
24-Hour Fax-On-Demand: 800-390-3232 (U.S. and Canada only) • Internet: <http://WWW.CEL.COM>

DATA SUBJECT TO CHANGE WITHOUT NOTICE

PRINTED IN USA ON RECYCLED PAPER -3/98