



Parameter	Rating	Units
Breakdown Voltage - $BV_{CEO}$	30	$V_P$
Current Transfer Ratio - CTR (Typ)	300	%
Saturation Voltage - $V_{CE(sat)}$	0.5	V
Input Control Current - $I_F$	1	mA

### Features

- Unidirectional Input
- Small 8-Pin Package
- 100mA Continuous Load Rating
- 3750V<sub>rms</sub> Input/Output Isolation
- Machine Insertable, Wave Solderable

### Applications

- Telecom Switching
- Tip/Ring Circuits
- Modem Switching (Laptop, Notebook, Pocket Size)
- Loop Detect
- Ringing Detect
- Current Sensing

### Description

LDA201 is a dual unidirectional optocoupler with single transistor outputs. Current transfer ratios range from 33% to 1000% with a typical value of 300%.

### Approvals

- UL Recognized Component: File # E76270
- CSA Certified Component: Certificate # 1175739

### Ordering Information

Part Number	Description
LDA201	8-Pin DIP (50/tube)
LDA201S	8-Pin Surface Mount (50/tube)
LDA201STR	8-Pin Surface Mount (1000/Reel)

### Pin Configuration

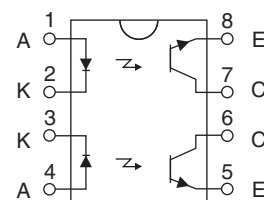

## Absolute Maximum Ratings

Parameter	Ratings	Units
Breakdown Voltage	30	$V_P$
Reverse Input Voltage	5	V
Input Control Current	100	mA
Peak (10ms)	1	A
Power Dissipation		
Input <sup>1</sup>	150	mW
Phototransistor <sup>2</sup>	150	mW
Isolation Voltage Input to Output	3750	$V_{rms}$
Operational Temperature	-40 to +85	°C
Storage Temperature	-40 to +125	°C

<sup>1</sup> Derate Linearly 1.33 mW/°C

<sup>2</sup> Derate Linearly 2.0 mW/°C

Electrical absolute maximum ratings are at 25°C

Absolute Maximum Ratings are stress ratings. Stresses in excess of these ratings can cause permanent damage to the device. Functional operation of the device at conditions beyond those indicated in the operational sections of this data sheet is not implied.

## Electrical Characteristics

Parameter	Conditions	Symbol	Min	Typ	Max	Units
<b>Output Characteristics @ 25°C</b>						
Phototransistor Breakdown Voltage	$I_C = 10\mu A$	$BV_{CEO}$	30	85	-	V
Phototransistor Dark Current	$V_{CEO} = 5V, I_F = 0mA$	$I_{CEO}$	-	10	500	nA
Saturation Voltage	$I_C = 2mA, I_F = 1mA$	$V_{CE(sat)}$	-	0.3	0.5	V
Current Transfer Ratio	$I_F = 1mA, V_{CE} = 0.5V$	CTR	33	300	1000	%
Output Capacitance	25V, f = 1MHz	$C_{OUT}$	-	6	-	pF
<b>Input Characteristics @ 25°C</b>						
Input Control Current	$I_C = 0.33mA, V_{CE} = 0.5V$	$I_F$	-	-	1	mA
Input Voltage Drop	$I_F = 5mA$	$V_F$	0.9	1.2	1.4	V
Reverse Input Current	$V_R = 5V$	$I_R$	-	-	10	$\mu A$
<b>Common Characteristics @ 25°C</b>						
Capacitance Input to Output	-	$C_{I/O}$	-	3	-	pF

## Switching Characteristics @ 25°C

Characteristic	Symbol	Test Condition	Typ	Units
Turn-On Time	$t_{ON}$	$V_{CC}=5V, I_F=2mA, R_L=1K\Omega$	7	$\mu s$
Turn-Off Time	$t_{OFF}$		20	

Switching Time Test Circuit

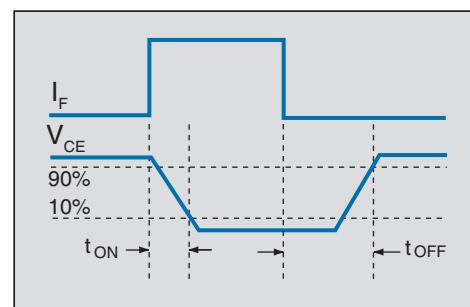
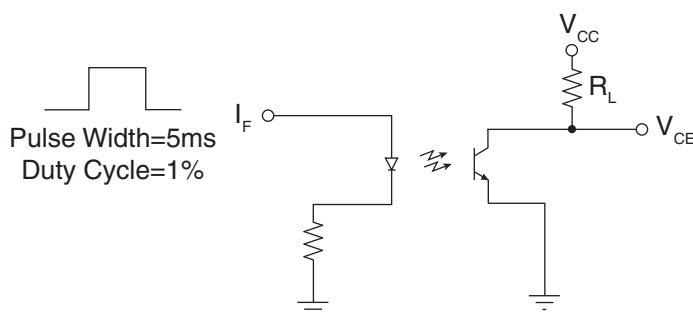

**PERFORMANCE DATA\***

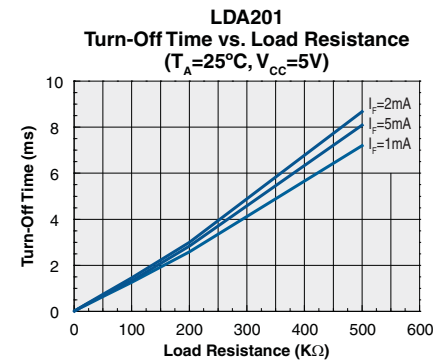
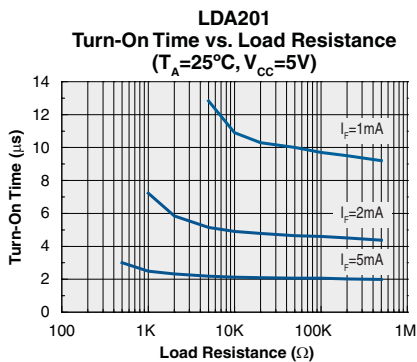
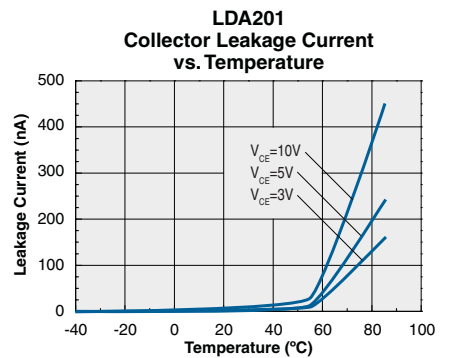
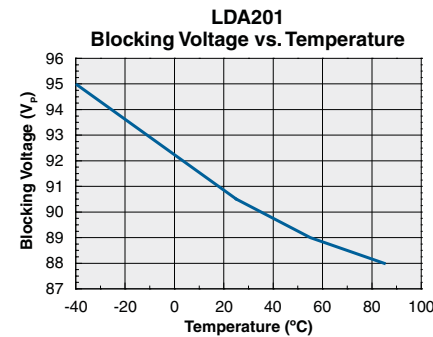
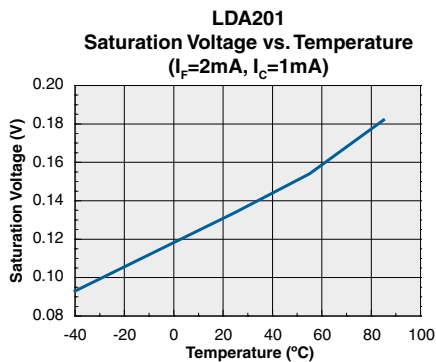
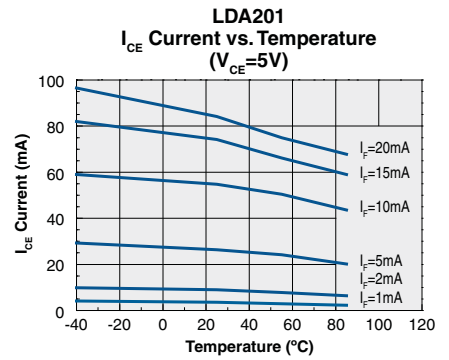
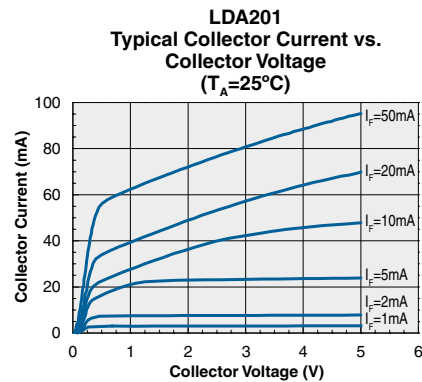
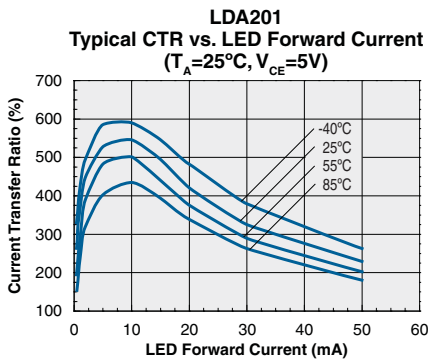
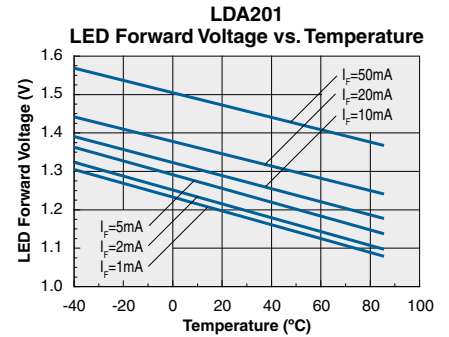
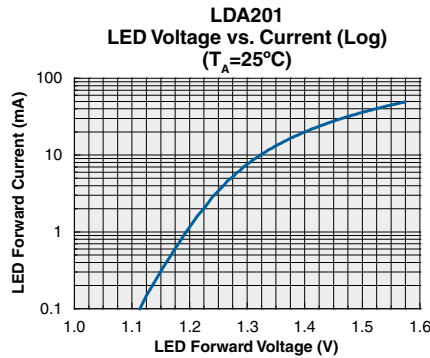
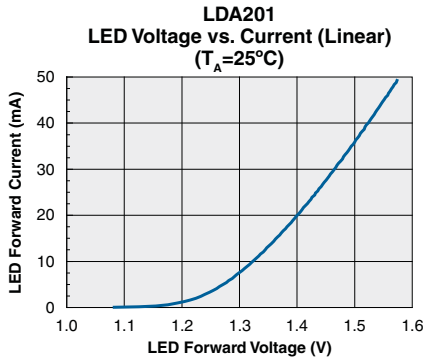

\*The Performance data shown in the graphs above is typical of device performance. For guaranteed parameters not indicated in the written specifications, please contact our application department.

**MANUFACTURING INFORMATION**

**Soldering**

For proper assembly, the component must be processed in accordance with the current revision of IPC/JEDEC standard J-STD-020. Failure to follow the recommended guidelines may cause permanent damage to the device resulting in impaired performance and/or a reduced lifetime expectancy.

**Washing**

Clare does not recommend ultrasonic cleaning or the use of chlorinated solvents.



**MECHANICAL DIMENSIONS**

**8-Pin DIP Through-Hole Package**

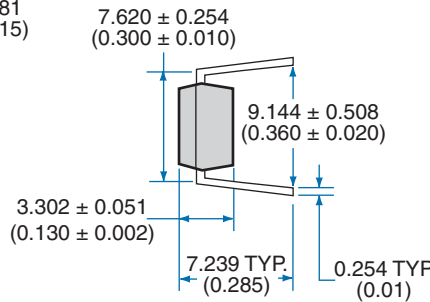
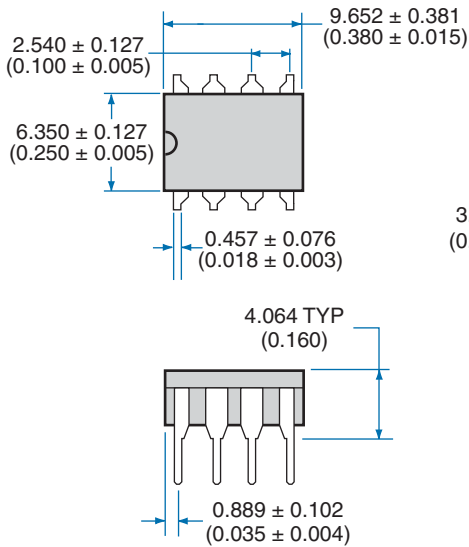

**PC Board Pattern**

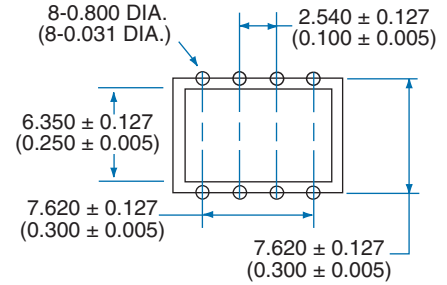

Dimensions  
mm  
(inches)

**8-Pin Surface Mount Package**

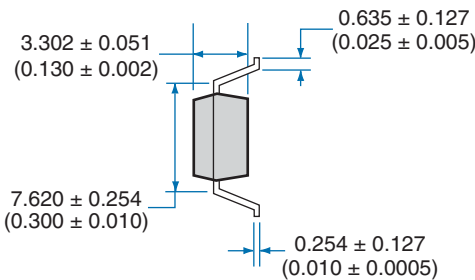
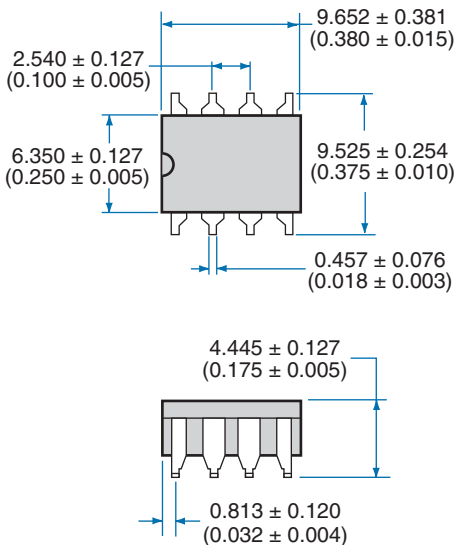

**Recommended PCB Land Pattern**

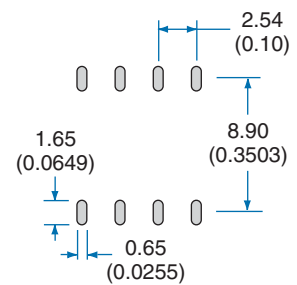

Dimensions  
mm  
(inches)

**Tape and Reel Packaging for 8-Pin Surface Mount Package**

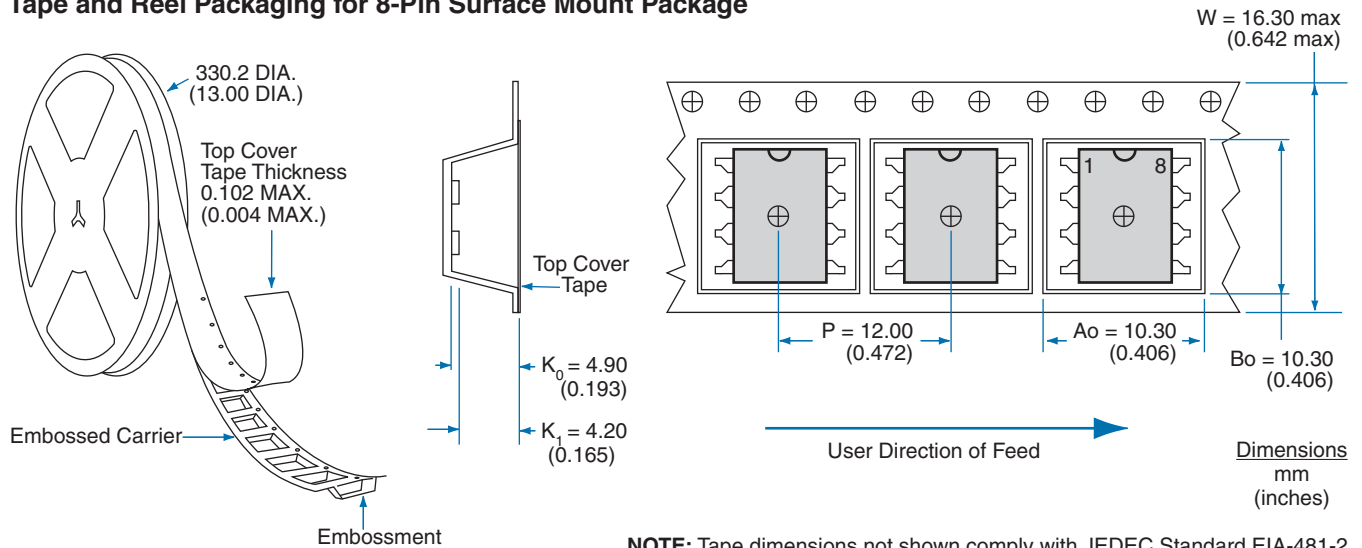

**NOTE:** Tape dimensions not shown comply with JEDEC Standard EIA-481-2

**For additional information please visit our website at: [www.clare.com](http://www.clare.com)**

Clare, Inc. makes no representations or warranties with respect to the accuracy or completeness of the contents of this publication and reserves the right to make changes to specifications and product descriptions at any time without notice. Neither circuit patent licenses nor indemnity are expressed or implied. Except as set forth in Clare's Standard Terms and Conditions of Sale, Clare, Inc. assumes no liability whatsoever, and disclaims any express or implied warranty, relating to its products including, but not limited to, the implied warranty of merchantability, fitness for a particular purpose, or infringement of any intellectual property right.

The products described in this document are not designed, intended, authorized or warranted for use as components in systems intended for surgical implant into the body, or in other applications intended to support or sustain life, or where malfunction of Clare's product may result in direct physical harm, injury, or death to a person or severe property or environmental damage. Clare, Inc. reserves the right to discontinue or make changes to its products at any time without notice.