



1.8V MULTI-QUEUE FLOW-CONTROL DEVICES
(128 QUEUES) 36 BIT WIDE CONFIGURATION
 1,179,648 bits
 2,359,296 bits
 4,718,592 bits

IDT72P51749
IDT72P51759
IDT72P51769

FEATURES

- Choose from among the following memory density options:
 IDT72P51749 — Total Available Memory = 1,179,648 bits
 IDT72P51759 — Total Available Memory = 2,359,296 bits
 IDT72P51769 — Total Available Memory = 4,718,592 bits
- Configurable from 1 to 128 Queues
- Default configuration of 128 or 64 symmetrical queues
- Default multi-queue device configurations
 – IDT72P51749: 256 x 36 x 128Q
 – IDT72P51759: 512 x 36 x 128Q
 – IDT72P51769: 1,024 x 36 x 128Q
- Default configuration can be augmented via the queue address bus
- Number of queues and individual queue sizes may be configured at master reset though serial programming
- 200 MHz High speed operation (5ns cycle time)
- 3.6ns access time
- Independent Read and Write access per queue
- User Selectable Bus Matching Options:

- x36 in to x36 out
- x36in to x18out
- x36in to x9out
- x18 in to x36 out
- x18 in to x18 out
- x18 in to x9 out
- x9 in to x36 out
- x9 in to x18 out
- x9 in to x9 out
- User selectable I/O: 1.5V HSTL, 1.8V eHSTL, or 2.5V LVTTL
- 100% Bus Utilization, Read and Write on every clock cycle
- Selectable First Word Fall Through (FWFT) or IDT standard mode of operation
- Ability to operate on packet or word boundaries
- Mark and Re-Write operation
- Mark and Re-Read operation
- Individual, Active queue flags (\overline{OR} / \overline{EF} , \overline{IR} / \overline{FF} , \overline{PAE} , \overline{PAF} , \overline{PR})
- 8 bit parallel flag status on both read and write ports
- Direct or polled operation of flag status bus
- Expansion of up to 256 queues
- JTAG Functionality (Boundary Scan)
- Available in a 256-pin PBGA, 1mm pitch, 17mm x 17mm
- HIGH Performance submicron CMOS technology
- Industrial temperature range (-40°C to +85°C) is available
- Green parts available, see Ordering Information

FUNCTIONAL BLOCK DIAGRAM

MULTI-QUEUE FLOW-CONTROL DEVICE

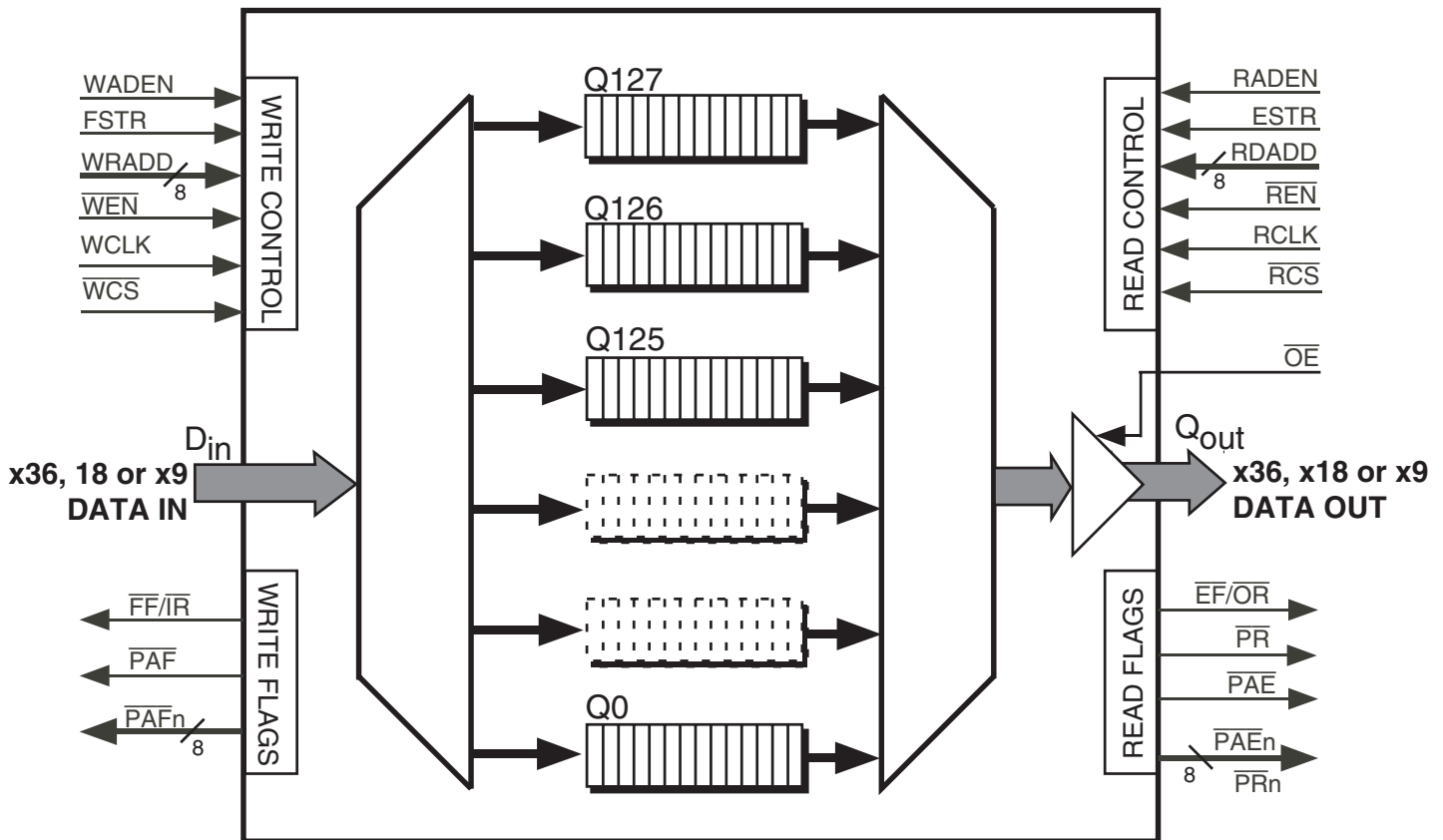

6714 drw01

IDT and the IDT logo are trademarks of Integrated Device Technology, Inc

COMMERCIAL AND INDUSTRIAL TEMPERATURE RANGES

FEBRUARY 2009

Table of Contents

Features	1
Description	5
Pin configuration	7
Detailed description	8
Pin descriptions	10
Pin number table	16
Recommended DC operating conditions	17
Absolute maximum ratings	17
DC electrical characteristics	18
AC electrical characteristics	20
Functional description	22
Serial Programming	23
Default Programming	23
Parallel Programming	23
Queue description	25
Configuration of the IDT Multi-queue flow-control device	25
Standard mode operation	26
Read Queue Selection and Read Operation	27
Switching Queues on the Write Port	29
Switching Queues on the Read Port	31
Flag description	42
$\overline{\text{PAFn}}$ Flag Bus Operation	42
Full Flag Operation	42
Empty or Output Ready Flag Operation ($\overline{\text{EF}}/\overline{\text{OR}}$)	42
Almost Full Flag	43
Almost Empty Flag	43
Packet Ready Flag	47
Packet Mode Demarcation bits	49
JTAG Interface	82
JTAG AC electrical characteristics	86
Ordering Information	87

List of Tables

Table 1 — Device programming mode comparison	22
Table 2 — Setting the queue programming mode during master reset	22
Table 3 — Mode Configuration	25
Table 4 — Write Address Bus, WRADD[7:0]	26
Table 5 — Read Address Bus, RDADD[7:0]	27
Table 6 — Write Queue Switch Operation	30
Table 7 — Read Queue Switch Operation	32
Table 8 — Same Queue Switch	32
Table 9 — Flag operation boundaries and Timing	45
Table 10 — Packet Mode Valid Byte for x36 bit word configuration	48
Table 11 — Bus-Matching Set-Up	52

List of Figures

Figure 1. Multi-Queue Flow-Control Device Block Diagram	6
Figure 2a. AC Test Load	19
Figure 2b. Lumped Capacitive Load, Typical Derating	19
Figure 3. Reference Signals	22
Figure 4. Device Programming Hierarchy	24
Figure 5. IDT Standard mode illustrated (Read Port)	25
Figure 6. First Word Fall Through (FWFT) mode illustrated (Read Port)	25
Figure 7. Write Port Switching Queues Signal Sequence	29
Figure 8. Switching Queues Bus Efficiency	29
Figure 9. Simultaneous Queue Switching	30
Figure 10. Read Port Switching Queues Signal Sequence	31
Figure 11. Switching Queues Bus Efficiency	31
Figure 12. Simultaneous Queue Switching	32
Figure 13. MARK and Re-Write Sequence	33
Figure 14. MARK and Re-Read Sequence	33
Figure 15. MARKing a Queue in Packet Mode - Write Queue MARK	34
Figure 16. MARKing a Queue in Packet Mode - Read Queue MARK	34
Figure 17. UN-MARKing a Queue in Packet Mode - Write Queue UN-MARK	35
Figure 18. UN-MARKing a Queue in Packet Mode - Read Queue UN-MARK	35
Figure 19. MARKing a Queue in FIFO Mode - Write Queue MARK	37
Figure 20. MARKing a Queue in FIFO Mode - Read Queue MARK	37
Figure 21. UN-MARKing a Queue in FIFO Mode - Write Queue UN-MARK	38
Figure 22. UN-MARKing a Queue in FIFO Mode - Read Queue UN-MARK	38
Figure 23. Leaving a MARK active on the Write Port	39
Figure 24. Leaving a MARK active on the Read Port	39
Figure 25. Inactivating a MARK on the Write Port Active	40
Figure 26. Inactivating a MARK on the Read Port Active	40
Figure 27. 36bit to 36bit word configuration	49
Figure 28. 36bit to 18bit word configuration	49
Figure 29. 36bit to 9bit word configuration	49
Figure 30. 18bit to 36bit word configuration	50
Figure 31. 18bit to 18bit word configuration	50
Figure 32. 18bit to 9bit word configuration	50
Figure 33. 9bit to 36bit word configuration	51
Figure 34. 9bit to 18bit word configuration	51
Figure 35. 9bit to 9bit word configuration	51
Figure 36. Bus-Matching Byte Arrangement	53
Figure 37. Master Reset	54
Figure 38. Default Programming	55
Figure 39. Parallel Programming	56
Figure 40. Queue Programming via Write Address Bus	57
Figure 41. Queue Programming via Read Address Bus	57
Figure 42. Serial Port Connection for Serial Programming	57
Figure 43. Serial Programming (2 Device Expansion)	58
Figure 44. Write Queue Select, Write Operation and Full Flag Operation	59
Figure 45. Write Queue Select and Mark	60
Figure 46. Write Operations in First Word Fall Through mode	61
Figure 47. Full Flag Timing in Expansion Configuration	62
Figure 48. Read Queue Select, Read Operation (IDT mode)	63
Figure 49. Read Queue Select, Read Operation (FWFT mode)	64
Figure 50. Read Queue Select and Mark (IDT mode)	65
Figure 51. Output Ready Flag Timing (In FWFT Mode)	66
Figure 52. Read Queue Selection with Read Operations (IDT mode)	67
Figure 53. Read Queue Select, Read Operation and \overline{OE} Timing	68
Figure 54. Writing in Packet Mode during a Queue change	69

List of Figures (Continued)

Figure 55. Reading in Packet Mode during a Queue change	70
Figure 56. Writing Demarcation Bits (Packet Mode)	71
Figure 57. Data Output (Receive) Packet Mode of Operation	72
Figure 58. Almost Full Flag Timing and Queue Switch	73
Figure 59. Almost Full Flag Timing	73
Figure 60. Almost Empty Flag Timing and Queue Switch (FWFT mode)	74
Figure 61. Almost Empty Flag Timing	74
Figure 62. $\overline{PAEn}/\overline{PRn}$ - Direct Mode - Status Word Selection	75
Figure 63. \overline{PAFn} - Direct Mode - Status Word Selection	75
Figure 64. \overline{PAEn} - Direct Mode, Flag Operation	76
Figure 65. \overline{PAFn} - Direct Mode, Flag Operation	77
Figure 66. \overline{PAFn} Bus - Polled Mode	78
Figure 67. Connecting Two 4M MQ 128Q devices in Expansion Mode	79
Figure 68. Connecting Three or more 4M MQ 128Q devices in Expansion Mode using WADDR bit 7 / RDADD bit 7	80
Figure 69. Boundary Scan Architecture	81
Figure 70. TAP Controller State Diagram	82
Figure 71. Standard JTAG Timing	85

DESCRIPTION

The IDT72P51749/72P51759/72P51769 multi-queue flow-control devices are single chips with up to 128 discrete configurable FIFO queues. All queues within the device have a common data input bus, (write port) and a common data output bus, (read port). Data written into the write port is directed to a specific queue via an internal de-multiplex operation, addressed by the write address bus (WRADD). Data read from the read port is accessed from a specific queue via an internal multiplex operation, addressed by the read address bus (RDADD). Data writes and reads can be performed at high speeds up to 200MHz, with access times of 3.6ns. Data write and read operations are totally independent of each other, a queue maybe selected on the write port and a different queue on the read port or both ports may select the same queue simultaneously.

The device provides Full flag and Empty flag status for the queue selected for write and read operations respectively. Also a Programmable Almost Full and Programmable Almost Empty flag for each queue is provided. Two 8 bit programmable flag busses are available, providing status of queues not selected for write or read operations. When 8 or less queues are configured in the device these flag busses provide an individual flag per queue, when more than 8 queues are used, either a Polled or Direct mode bus operation provides the flag busses with all queues status.

Bus Matching is available on this device, either port can be 9 bits, 18 bits or 36 bits wide. When Bus Matching is used the device ensures the logical transfer of data throughput in a Little Endian manner.

A packet mode of operation is also provided. Packet mode provides a packet ready flag output (PR) indicating when at least one (or more) packets of data

within a queue is available for reading. The Packet Ready indicator is generated upon detection of the start and end of packet demarcation bits. The multi-queue device then provides the user with an internally generated packet ready status per queue.

The user has full flexibility configuring queues within the device, being able to program the total number of queues between 1 and 128, the individual queue depths being independent of each other. The programmable flag positions are also user programmable. All programming is done via a dedicated serial port. If the user does not wish to program the multi-queue device, a default option is available that configures the device in a predetermined manner.

A Master Reset must be provided to the device. A Master Reset latches in configuration/setup pins and must be performed before further programming of the device can take place. On the rising edge of master reset the device operating mode is set, the device programming mode (serial, parallel or default) is set and the expansion configuration device type (master or slave) is set.

The multi-queue flow-control device has the capability of operating its I/O in either 2.5V LVTTTL, 1.5V HSTL or 1.8V eHSTL mode. The type of I/O is selected via the IOSEL input. The core supply voltage (VDD) to the multi-queue is 1.8V, however the output levels can be set independently via a separate supply, VDDO.

A JTAG test port is provided, here the multi-queue flow-control device has a fully functional Boundary Scan feature, compliant with IEEE 1149.1 Standard Test Access Port and Boundary Scan Architecture.

See Figure 1, *Multi-Queue Flow-Control Device Block Diagram* for an outline of the functional blocks within the device.

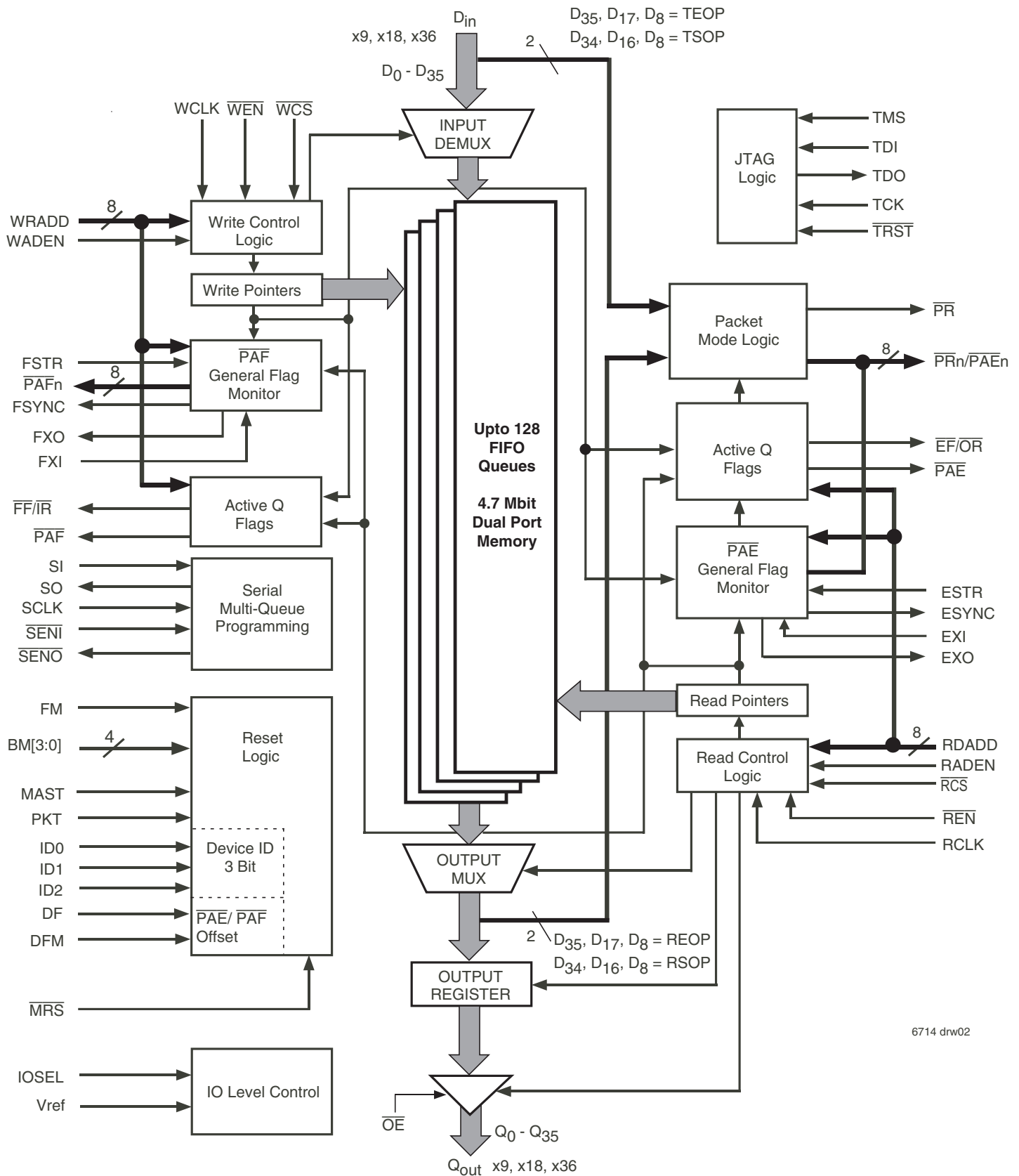

6714 drw02

Figure 1. Multi-Queue Flow-Control Device Block Diagram

PIN CONFIGURATION

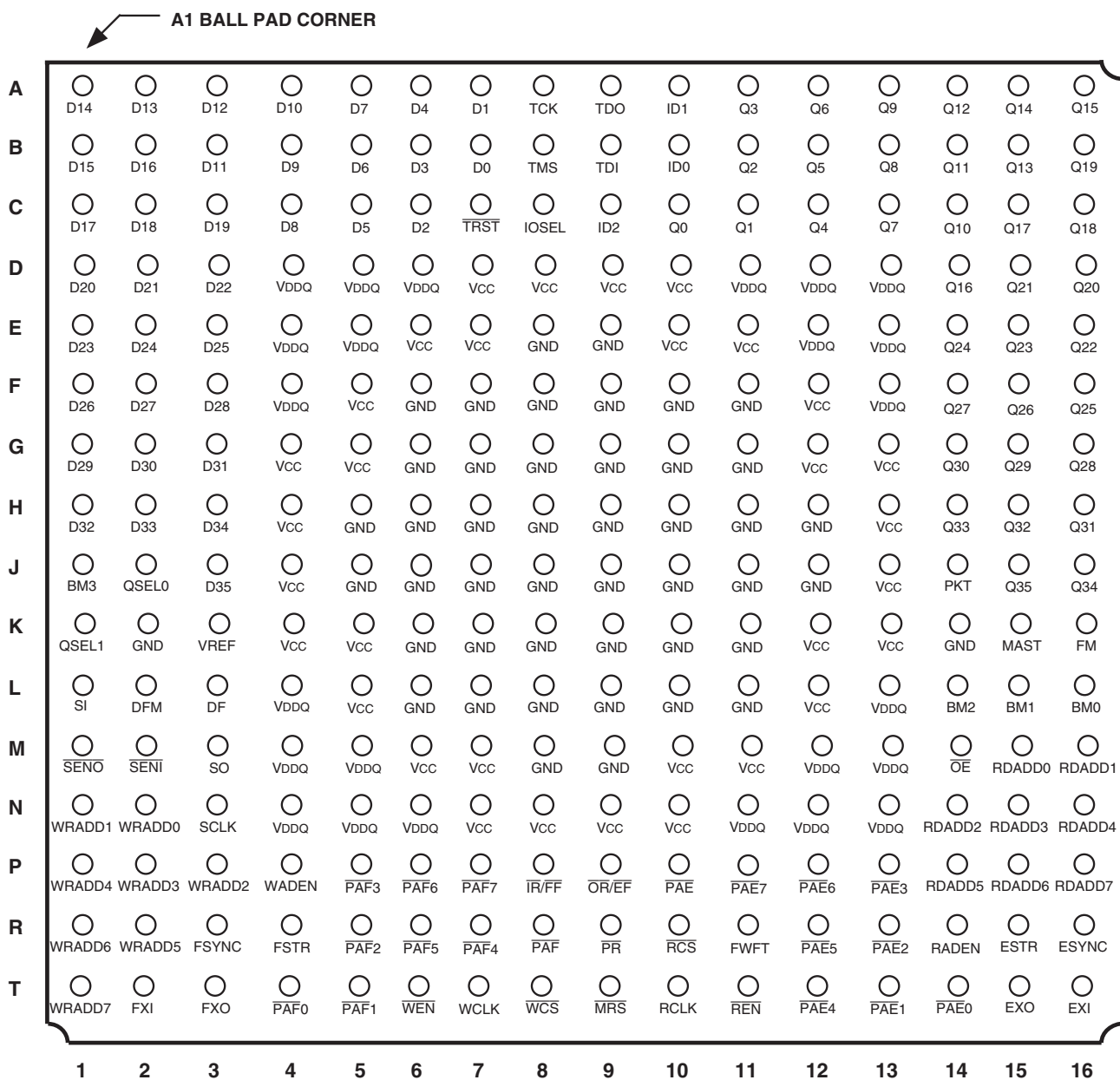

6714 dnr03

PBGA (BB256-1, order code: BB)
 TOP VIEW

DETAILED DESCRIPTION

MULTI-QUEUE STRUCTURE

The IDT multi-queue flow-control device has a single data input port and single data output port with up to 128 FIFO queues in parallel buffering between the two ports. The user can setup between 1 and 128 Queues within the device. These queues can be configured to utilize the total available memory, providing the user with full flexibility and ability to configure the queues to be various depths, independent of one another.

MEMORY ORGANIZATION/ALLOCATION

The memory is organized into what is known as "blocks", each block being 256 x36 bits. When the user is configuring the number of queues and individual queue sizes the user must allocate the memory to respective queues, in units of blocks, that is, a single queue can be made up from 0 to m blocks, where m is the total number of blocks available within a device. Also the total size of any given queue must be in increments of 256 x36. For the IDT72P51749, IDT72P71759 and IDT72P51769 the Total Available Memory is 128,256, and 512 blocks respectively (a block being 256 x36). Queues can be built from these blocks to make any size queue desired and any number of queues desired.

BUS WIDTHS

The input port is common to all queues within the device, as is the output port. The device provides the user with Bus Matching options such that the input port and output port can be either x9, x18 or x36 bits wide, the read and write port widths can be set independently of one another. Because a ports are common to all queues the width of the queues is not individually set. The input width of all queues are the same and the output width of all queues are the same.

WRITING TO & READING FROM THE MULTI-QUEUE

Data being written into the device via the input port is directed to a discrete queue via the write queue address input. Conversely, data being read from the device read port is read from a queue selected via the read queue address input. Data can be simultaneously written into and read from the same queue or different queues. Once a queue is selected for data writes or reads, the writing and reading operation is performed in the same manner as a conventional IDT synchronous FIFO, utilizing clocks and enables, there is a single clock and enable per port. When a specific queue is addressed on the write port, data placed on the data inputs is written to that queue sequentially based on the rising edge of a write clock provided setup and hold times are met. Conversely, data is read on to the output port after an access time from a rising edge on a read clock.

The operation of the write port is comparable to the function of a conventional FIFO operating in standard IDT mode. Write operations can be performed on the write port provided that the queue currently selected is not full, a full flag output provides status of the selected queue. The operation of the read port is comparable to the function of a conventional FIFO operating in FWFT mode. When a queue is selected on the output port, the next word in that queue will automatically fall through to the output register. All subsequent words from that queue require an enabled read cycle. Data cannot be read from a selected queue if that queue is empty, the read port provides an Empty flag indicating when data read out is valid. If the user switches to a queue that is empty, the last word from the previous queue will remain on the output bus. In addition to First Word Fall Through (FWFT) the device can operate in IDT Standard mode or packet mode. In IDT Standard mode the read port provides a word to the output bus (Qout) for each clock cycle that \overline{REN} is asserted. Refer to Figure 48, *Read Queue Select, Read Operation (IDT Mode)*. In packet mode the device asserts a packet ready status flag to indicate one or more packets are available for reading.

As mentioned, the write port has a full flag, providing full status of the selected queue. Along with the full flag a dedicated almost full flag is provided, this almost full flag is similar to the almost full flag of a conventional IDT FIFO. The device provides a user programmable almost full flag for all 128 queues and when a respective queue is selected on the write port, the almost full flag provides status for that queue. Conversely, the read port has an Empty flag, providing status of the data being read from the queue selected on the read port. As well as the Empty flag the device provides a dedicated almost empty flag. This almost empty flag is similar to the almost empty flag of a conventional IDT FIFO. The device provides a user programmable almost empty flag for each 128 queues and when a respective queue is selected on the read port, the almost empty flag provides status for that queue.

PROGRAMMABLE FLAG BUSES

In addition to these dedicated flags, full & almost full on the write port and Output Ready & almost empty on the read port, there are two flag status busses. An almost full flag status bus is provided, this bus is 8 bits wide. Also, an almost empty flag status bus is provided, again this bus is 8 bits wide. The purpose of these flag busses is to provide the user with a means by which to monitor the data levels within queues that may not be selected on the write or read port. As mentioned, the device provides almost full and almost empty registers (programmable by the user) for each of the 128 queues in the device.

In the IDT72P51749/72P51759/72P51769 multi-queue flow-control devices the user has the option of utilizing anywhere between 1 and 128 queues, therefore the 8 bit flag status busses are multiplexed between the 128 queues, a flag bus can only provide status for 8 of the 128 queues at any moment, this is referred to as a "Status Word", such that when the bus is providing status of queues 1 through 8, this is status word 1, when it is queues 9 through 16, this is status word 2 and so on up to status word 16. If less than 128 queues are setup in the device, there are still 4 status words, such that in "Polled" mode of operation the flag bus will still cycle through 4 status words. If for example only 22 queues are setup, status words 1 and 2 will reflect status of queues 1 through 8 and 9 through 16 respectively. Status word 3 will reflect the status of queues 17 through 22 on the least significant 6 bits, the most significant 2 bits of the flag bus are don't care. The remaining status words are not used as there are no queues to report.

The flag busses are available in two user selectable modes of operation, "Polled" or "Direct". When operating in polled mode a flag bus provides status of each status word sequentially, that is, on each rising edge of a clock the flag bus is updated to show the status of each status word in order. The rising edge of the write clock will update the almost full bus and a rising edge on the read clock will update the almost empty bus. The mode of operation is always the same for both the almost full and almost empty flag busses. When operating in direct mode, the status word on the flag bus is selected by the user. So the user can actually address the status word to be placed on the flag status busses, these flag busses operate independently of one another. Addressing of the almost full flag bus is done via the write port and addressing of the almost empty flag bus is done via the read port.

PACKET READY

The multi-queue flow-control device also offers a "Packet Mode" operation. Packet Mode is user selectable. In packet mode with a x36 bit word length, users can define the length of packets or frame by using the two most significant bits of the word. In a 36-bit word, bit 34 is used to mark the Start of Packet (SOP) and bit 35 is used to mark the End of Packet (EOP) as shown in Table 10. When writing data into a given queue, the first word being written is marked, by the user setting bit 34 as the "Start of Packet" (SOP) and the last word written is marked as the "End of Packet" (EOP) with all words written between the Start of Packet (SOP) marker (bit 34) and the End of packet (EOP) packet marker

(bit 35) constituting the entire packet. A packet can be any length the user desires, up to the total available memory in the multi-queue device. The device monitors the SOP (bit 34) and looks for the word that contains the EOP (bit 35). The read port is supplied with an additional status flag, "Packet Ready". The Packet Ready (\overline{PR}) flag in conjunction with Empty Flag or Output Ready flag ($\overline{EF/OR}$) indicates when at least one packet is available to read. When in packet mode the almost empty flag status, provides packet ready flag status for individual queues.

EXPANSION (IDT STANDARD MODE)

Expansion of multi-queue devices is possible, by connecting the devices in a parallel fashion. Expansion achieves both depth or queue expansion. Expansion of devices is supported only in IDT Standard mode. Depth Expansion means expanding the depths of individual queues. Queue expansion means increasing the total number of queues available. Depth expansion

is possible by virtue of the fact that more memory blocks within a multi-queue device can be allocated to a fewer number of queues to increase the depth of each queue. For example, depth expansion of 2 devices provides the possibility of 2 queues of 4096K bits, each queue being setup within a single device utilizing all memory blocks available to produce a single queue. This is the deepest queue that can setup within a device.

For queue expansion a maximum number of 256 queues (2 x 128 queues) may be setup. If fewer queues are desired, then more memory blocks will be available to increase queue depths if desired. When connecting multi-queue devices in expansion configuration all respective input pins (data & control) and output pins (data & flags), should be "connected" together between individual devices. Refer to Figure 67, *Connecting Two 4M MQ 128Q devices in Expansion Mode*, and Figure 68, *Connecting Three or more 4M MQ 128Q in Expansion mode using WRADD bit 7 / RDADD bit 7* for device connection details.

PIN DESCRIPTIONS

Symbol & (Pin No.)	Name	I/O TYPE	Description
BM [3:0] (J1, L14,15,16)	Bus Matching	HSTL-LVTTL INPUT	These pins define the bus width of the input write port and the output read port of the device. The bus widths are set during a Master Reset cycle. The BM[3:0] signals must meet the setup and hold time requirements of Master Reset and must not toggle/change state after a Master Reset cycle.
D[35:0] Din (See Pin No. table for details)	Data Input Bus	HSTL-LVTTL INPUT	These are the 36 data input pins. Data is written into the device via these input pins on the rising edge of WCLK provided that \overline{WEN} is LOW. Note, that in Packet mode D32-D35 may be used as packet markers, please see packet ready functional discussion for more detail. Due to bus matching not all inputs may be used, any unused inputs should be tied LOW. D[35] Transmit End of Packet (TEOP) D[34] Transmit Start of Packet (TSOP) D[33:32] User definable bits D[31:0] Data input bits
DF ⁽¹⁾ (L3)	Default Flag	HSTL-LVTTL INPUT	If the user requires default programming of the multi-queue device, this pin must be setup before Master Reset and must not toggle during any device operation. The state of this input at master reset determines the value of the $\overline{PAE}/\overline{PAF}$ flag offsets. If DF is LOW the value is 8, if DF is HIGH the value is 128.
DFM ⁽¹⁾ (L2)	Default Mode	HSTL-LVTTL INPUT	The multi-queue device requires programming after master reset. The user can do this serially via the serial port, or via parallel programming or by the default programming option. The default programming option provides a pre-defined configuration. If DFM is LOW at master reset then serial mode will be selected, if HIGH then default mode is selected.
$\overline{EF}/\overline{OR}$ (P9)	Empty Flag/ Output Ready	HSTL-LVTTL OUTPUT	This signal is bi-modal. When IDT Standard mode is selected the pin provides Empty Flag (\overline{EF}) status. When FWFT mode is selected the pin provides output ready (\overline{OR}) status. This output flag provides Output Ready status for the data word present on the multi-queue flow-control device data output bus, Qout in FWFT mode. This flag is a 2-stage delayed to match the data output path delay. There is a 3 RCLK cycle delay in IDT Standard mode and a 4 cycle delay for FWFT mode from the time a given queue is selected for reads, to the time the \overline{OR} flag represents the data in that queue. When a selected queue on the read port is read to empty, the \overline{OR} flag will go HIGH, indicating that data on the output bus is not valid. The \overline{OR} flag also has High-Impedance capability, required when multiple devices are used and the \overline{OR} flags are tied together.
ESTR (R15)	$\overline{PAE}n$ Flag Bus Strobe	HSTL-LVTTL INPUT	If direct operation of the $\overline{PAE}n$ bus has been selected, the ESTR input is used in conjunction with RCLK and the RDADD bus to select a status word of queues to be placed on to the $\overline{PAE}n$ bus outputs. A status word addressed via the RDADD bus is selected on the rising edge of RCLK provided that ESTR is HIGH. If Polled operations has been selected, ESTR should be tied inactive, LOW. Note, that a $\overline{PAE}n$ flag bus selection cannot be made, (ESTR must NOT go active) until programming of the part has been completed and $\overline{SEN0}$ has gone LOW.
ESYNC (R16)	$\overline{PAE}n$ Bus Sync	HSTL-LVTTL OUTPUT	ESYNC is an output from the multi-queue device that provides a synchronizing pulse for the $\overline{PAE}n$ bus during Polled operation of the $\overline{PAE}n$ bus. During Polled operation each status word of queue status flags is loaded on to the $\overline{PAE}n$ bus outputs sequentially based on RCLK. The first RCLK rising edge loads status word 1 on to $\overline{PAE}n$, the second RCLK rising edge loads status word 2 and so on. The fifth RCLK rising edge will again load status word 1. During the RCLK cycle that status word 1 of a selected device is placed on to the $\overline{PAE}n$ bus, the ESYNC output will be HIGH. For all other status words of that device, the ESYNC output will be LOW.
EXI (T16)	$\overline{PAE}n$ Bus Expansion In	HSTL-LVTTL INPUT	The EXI input is used when multi-queue devices are connected in expansion configuration and Polled $\overline{PAE}n$ bus operation has been selected. EXI of device 'N' connects directly to EXO of device 'N-1'. The EXI receives a token from the previous device in a chain. In single device mode the EXI input must be tied LOW if the $\overline{PAE}n$ bus is operated in direct mode. If the $\overline{PAE}n$ bus is operated in polled mode the EXI input must be connected to the EXO output of the same device. In expansion configuration the EXI of the first device should be tied LOW, when direct mode is selected.
EXO (T15)	$\overline{PAE}n$ Bus Expansion Out	HSTL-LVTTL OUTPUT	EXO is an output that is used when multi-queue devices are connected in expansion configuration and Polled $\overline{PAE}n$ bus operation has been selected. EXO of device 'N' connects directly to EXI of device 'N+1'. This pin pulses when device N has placed its final (4th) status word on to the $\overline{PAE}n$ bus with respect to RCLK. This pulse (token) is then passed on to the next device in the chain 'N+1' and on the next RCLK rising edge the first status word of device N+1 will be loaded on to the $\overline{PAE}n$ bus. This continues through the chain and EXO of the last device is then looped back to EXI of the first device. The ESYNC output of each device in the chain provides synchronization to the user of this looping event.

PIN DESCRIPTIONS (CONTINUED)

Symbol & Pin No.	Name	I/O TYPE	Description
$\overline{FF}/\overline{IR}$ (P8)	Full Flag/ Input Ready	HSTL-LVTTL OUTPUT	This pin provides the full flag output for the active Queue, that is, the queue selected on the input port for write operations, (selected via WCLK, WRADD bus and WADEN). On the 3rd WCLK cycle after a queue selection, this flag will show the status of the newly selected queue. Data can be written to this queue on the next cycle provided \overline{FF} is HIGH. This flag has High-Impedance capability, this is important during expansion of devices, when the \overline{FF} flag output of up to 2 devices may be connected together on a common line. The device with a queue selected takes control of the \overline{FF} bus, all other devices place their \overline{FF} output into High-Impedance. When a queue selection is made on the write port this output will switch from High-Impedance control on the next WCLK cycle. This flag is synchronized to WCLK.
FM ⁽¹⁾ (K16)	Flag Mode	HSTL-LVTTL INPUT	This pin is setup before a master reset and must not toggle during any device operation. The state of the FM pin during Master Reset will determine whether the \overline{PAFn} and \overline{PAEn} flag busses operate in either Polled or Direct mode. If this pin is HIGH the mode is Polled, if LOW then it will be Direct.
FSTR (R4)	\overline{PAFn} Flag Bus Strobe	HSTL-LVTTL INPUT	If direct operation of the \overline{PAFn} bus has been selected, the FSTR input is used in conjunction with WCLK and the WRADD bus to select a status word of queues to be placed on to the \overline{PAFn} bus outputs. A status word addressed via the WRADD bus is selected on the rising edge of WCLK provided that FSTR is HIGH. If Polled operations has been selected, FSTR should be tied inactive, LOW. Note, that a \overline{PAFn} flag bus selection cannot be made, (FSTR must NOT go active) until programming of the part has been completed and \overline{SENO} has gone LOW.
FSYNC (R3)	\overline{PAFn} Bus Sync	HSTL-LVTTL OUTPUT	FSYNC is an output from the multi-queue device that provides a synchronizing pulse for the \overline{PAFn} bus during Polled operation of the \overline{PAFn} bus. During Polled operation each status word of queue status flags is loaded on to the \overline{PAFn} bus outputs sequentially based on WCLK. The first WCLK rising edge loads status word 1 on to \overline{PAFn} , the second WCLK rising edge loads status word 2 and so on. The fifth WCLK rising edge will again load status word 1. During the WCLK cycle that status word 1 of a selected device is placed on to the \overline{PAFn} bus, the FSYNC output will be HIGH. For all other status words of that device, the FSYNC output will be LOW.
FWFT (R11)	First Word Fall Through	HSTL-LVTTL INPUT	First word fall through (FWFT) or IDT Standard mode is selected during a Master Reset cycle. To select FWFT mode assert the FWFT signal = HIGH, if FWFT = LOW during the master reset then IDT Standard mode is selected.
FXI (T2)	\overline{PAFn} Bus Expansion In	HSTL-LVTTL INPUT	The FXI input is used when multi-queue devices are connected in expansion configuration and Polled \overline{PAFn} bus operation has been selected. FXI of device 'N' connects directly to FXO of device 'N-1'. The FXI receives a token from the previous device in a chain. In single device mode the FXI input must be tied LOW if the \overline{PAFn} bus is operated in direct mode. If the \overline{PAFn} bus is operated in polled mode the FXI input must be connected to the FXO output of the same device. In expansion configuration the FXI of the first device should be tied LOW, when direct mode is selected.
FXO (T3)	\overline{PAFn} Bus Expansion Out	HSTL-LVTTL OUTPUT	FXO is an output that is used when multi-queue devices are connected in expansion configuration and Polled \overline{PAFn} bus operation has been selected. FXO of device 'N' connects directly to FXI of device 'N+1'. This pin pulses when device N has placed its final (4th) status word on to the \overline{PAFn} bus with respect to WCLK. This pulse (token) is then passed on to the next device in the chain 'N+1' and on the next WCLK rising edge the first status word of device N+1 will be loaded on to the \overline{PAFn} bus. This continues through the chain and FXO of the last device is then looped back to FXI of the first device. The FSYNC output of each device in the chain provides synchronization to the user of this looping event.
ID[2:0] ⁽¹⁾ (ID2-C9 ID1-A10 ID0-B10)	Device ID Pins	HSTL-LVTTL INPUT	For the 128Q multi-queue device the WRADD and RDADD address busses are 8 bits wide. When a queue selection takes place the MSb of this 8 bit address bus are used to address the specific device (the 0-6 LSb's are used to address the queue within that device). During write/read operations the MSb of the address are compared to the device ID pins. In an eight device expansion configuration, the first device in a chain of multi-queue's (connected in expansion configuration), may be setup as '000' (this is referred to as the Master Device), the second as '001', however the ID does not have to match the device order. In single device mode these pins should be setup as '000' and the MSb of the WRADD and RDADD address busses should be tied LOW. The ID[2:0] inputs setup a respective devices ID during master reset. These ID pins must not toggle during any device operation. Note, the device selected as the 'Master' must be ID '000'. In serial programming, the master device (ID 000) must be programmed last.

PIN DESCRIPTIONS (CONTINUED)

Symbol & Pin No.	Name	I/O TYPE	Description
IOSEL (C8)	IO Select	LVTTTL INPUT	This pin is used to select either HSTL or 2.5V LVTTTL operation for the I/O. If HSTL or eHSTL I/O are required then IOSEL should be tied HIGH (V _{DDQ}). If LVTTTL I/O are required then it should be tied LOW.
MAST ⁽¹⁾ (K15)	Master Device	HSTL-LVTTTL INPUT	The state of this input at Master Reset determines whether a given device (within a chain of devices), is the Master device or a Slave. If this pin is HIGH, the device is the master if it is LOW then it is a Slave. The master device is the first to take control of all outputs after a master reset, all slave devices go to High-Impedance, preventing bus contention. If a multi-queue device is being used in single device mode, this pin must be set HIGH.
$\overline{\text{MRS}}$ (T9)	Master Reset	HSTL-LVTTTL INPUT	A master reset is performed by taking $\overline{\text{MRS}}$ from HIGH to LOW, to HIGH. Device programming is required after master reset.
$\overline{\text{OE}}$ (M14)	Output Enable	HSTL-LVTTTL INPUT	The Output enable signal is an Asynchronous signal used to provide three-state control of the multi-queue data output bus, Qout. If a device has been configured as a "Master" device, the Qout data outputs will be in a Low Impedance condition if the $\overline{\text{OE}}$ input is LOW. If $\overline{\text{OE}}$ is HIGH then the Qout data outputs will be in High Impedance. If a device is configured a "Slave" device, then the Qout data outputs will always be in High Impedance until that device has been selected on the Read Port, at which point $\overline{\text{OE}}$ provides three-state of that respective device.
$\overline{\text{PAE}}$ (P10)	Programmable Almost-Empty Flag	HSTL-LVTTTL OUTPUT	This pin provides the Almost-Empty flag status for the Queue that has been selected on the output port for read operations, (selected via RCLK, RDADD and RADEN). This pin is LOW when the selected Queue is almost-empty. This flag output may be duplicated on one of the $\overline{\text{PAE}}_n$ bus lines. This flag is synchronized to RCLK.
$\overline{\text{PAE}}_n/\overline{\text{PR}}_n$ ($\overline{\text{PAE}}_7$ -P11 $\overline{\text{PAE}}_6$ -P12 $\overline{\text{PAE}}_5$ -R12 $\overline{\text{PAE}}_4$ -T12 $\overline{\text{PAE}}_3$ -P13 $\overline{\text{PAE}}_2$ -R13 $\overline{\text{PAE}}_1$ -T13 $\overline{\text{PAE}}_0$ -T14)	Programmable Almost-Empty Flag Bus/ Packet Ready Flag Bus	HSTL-LVTTTL OUTPUT	On the 128Q device the $\overline{\text{PAE}}_n/\overline{\text{PR}}_n$ bus is 8 bits wide. During a Master Reset this bus is setup for either Almost Empty mode or Packet mode. This output bus provides $\overline{\text{PAE}}/\overline{\text{PR}}$ status of 8 queues (1 status word), within a selected device, having a maximum of 16 status words. During Queue read/write operations these outputs provide programmable empty flag status or packet ready status, in either direct or polled mode. The mode of flag operation is determined during master reset via the state of the FM input. This flag bus is capable of High-Impedance state, this is important during expansion of multi-queue devices. During direct operation the $\overline{\text{PAE}}_n/\overline{\text{PR}}_n$ bus is updated to show the $\overline{\text{PAE}}/\overline{\text{PR}}$ status of a status word of queues within a selected device. Selection is made using RCLK, ESTR and RDADD. During Polled operation the $\overline{\text{PAE}}_n/\overline{\text{PR}}_n$ bus is loaded with the $\overline{\text{PAE}}/\overline{\text{PR}}$ status of multi-queue flow-control status words sequentially based on the rising edge of RCLK. $\overline{\text{PAE}}$ or $\overline{\text{PR}}$ operation is determined by the state of PKT during master reset.
$\overline{\text{PAF}}$ (R8)	Programmable Almost-Full Flag	HSTL-LVTTTL OUTPUT	This pin provides the Almost-Full flag status for the Queue that has been selected on the input port for write operations, (selected via WCLK, WRADD and WADEN). This pin is LOW when the selected Queue is almost-full. This flag output may be duplicated on one of the $\overline{\text{PAF}}_n$ bus lines. This flag is synchronized to WCLK.
$\overline{\text{PAF}}_n$ ($\overline{\text{PAF}}_7$ -P7 $\overline{\text{PAF}}_6$ -P6 $\overline{\text{PAF}}_5$ -R6 $\overline{\text{PAF}}_4$ -R7 $\overline{\text{PAF}}_3$ -P5 $\overline{\text{PAF}}_2$ -R5 $\overline{\text{PAF}}_1$ -T5 $\overline{\text{PAF}}_0$ -T4)	Programmable Almost-Full Flag Bus	HSTL-LVTTTL OUTPUT	On the 128Q device the $\overline{\text{PAF}}_n$ bus is 8 bits wide. At any one time this output bus provides $\overline{\text{PAF}}$ status of 8 queues (1 status word), within a selected device, having a maximum of 16 status words. During Queue read/write operations these outputs provide programmable full flag status, in either direct or polled mode. The mode of flag operation is determined during master reset via the state of the FM input. This flag bus is capable of High-Impedance state, this is important during expansion of multi-queue devices. During direct operation the $\overline{\text{PAF}}_n$ bus is updated to show the $\overline{\text{PAF}}$ status of a status word of queues within a selected device. Selection is made using WCLK, FSTR, WRADD and WADEN. During Polled operation the $\overline{\text{PAF}}_n$ bus is loaded with the $\overline{\text{PAF}}$ status of multi-queue flow-control status words sequentially based on the rising edge of WCLK.
PKT ⁽¹⁾ (J14)	Packet Mode	HSTL-LVTTTL INPUT	The state of this pin during a Master Reset will determine whether the part is operating in Packet mode providing both a Packet Ready ($\overline{\text{PR}}$) output and a Programmable Almost Empty ($\overline{\text{PAE}}$) discrete output, or standard mode, providing a ($\overline{\text{PAE}}$) output only. If this pin is HIGH during Master Reset the part will operate in packet mode, if it is LOW then almost empty mode. If packet mode has been selected the read port flag bus becomes packet ready flag bus, $\overline{\text{PR}}_n$ and the discrete packet ready flag, $\overline{\text{PR}}$ is functional. If almost empty operation has been selected then the flag bus provides almost empty status, $\overline{\text{PAE}}_n$ and the discrete almost empty flag, $\overline{\text{PAE}}$ is functional, the $\overline{\text{PR}}$ flag is inactive and should not be connected. PacketReady utilizes user marked locations to identify start and end of packets being written into the device.

PIN DESCRIPTIONS (CONTINUED)

Symbol & Pin No.	Name	I/O TYPE	Description
\overline{PR} (R9)	Packet Ready Flag	HSTL-LVTTL OUTPUT	If packet mode has been selected this flag output provides Packet Ready status of the Queue selected for read operations. During a master reset the state of the PKT input determines whether Packet mode of operation will be used. If Packet mode is selected, then the condition of the \overline{PR} flag and $\overline{EF}/\overline{OR}$ signal are asserted indicates a packet is ready for reading. The user must mark the start of a packet and the end of a packet when writing data into a queue. Using Start Of Packet (SOP) and End Of Packet (EOP) markers, the multi-queue device sets \overline{PR} LOW if one or more "complete" packets are available in the queue. A complete packet(s) must be written before the user is allowed to switch queues.
Q[35:0] Qout (See Pin No. table for details)	Data Output Bus	HSTL-LVTTL OUTPUT	These are the 36 data output pins. Data is read out of the device via these output pins on the rising edge of RCLK provided that \overline{REN} is LOW, \overline{OE} is LOW and the Queue is selected. Note, that in Packet Ready mode Q32-Q35 may be used as packet markers, please see packet ready functional discussion for more detail. Due to bus matching not all outputs may be used, any unused outputs should not be connected.
QSEL[1:0] (QSEL1-K1 QSEL0-J2)	Queue Select	HSTL-LVTTL INPUT	The QSEL pins provides various queue programming options. Refer to Table 2, for details. 1. A QSEL value of 00, enables the user to program the number of Queues using the Write Address bus. 2. A QSEL value of 01, enables the user to program the number of Queues using the Read Address bus. 3. A QSEL value of 10, Selects a configuration of 64 Queues. 4. A QSEL value of 11, selects a configuration of 128 Queues
RADEN (R14)	Read Address Enable	HSTL-LVTTL INPUT	The RADEN input is used in conjunction with RCLK and the RDADD address bus to select a queue to be read from. A queue addressed via the RDADD bus is selected on the rising edge of RCLK provided that RADEN is HIGH. RADEN should be asserted (HIGH) only during a queue change cycle(s). RADEN should not be permanently tied HIGH. RADEN cannot be HIGH for the same RCLK cycle as ESTR. Note, that a read queue selection cannot be made, (RADEN must NOT go active) until programming of the part has been completed and $\overline{SEN0}$ has gone LOW.
RCLK (T10)	Read Clock	HSTL-LVTTL INPUT	When enabled by \overline{REN} , the rising edge of RCLK reads data from the selected queue via the output bus Qout. The queue to be read is selected via the RDADD address bus and a rising edge of RCLK while RADEN is HIGH. A rising edge of RCLK in conjunction with ESTR and RDADD will also select the $\overline{PAEn}/\overline{PRn}$ flag status word to be placed on the $\overline{PAEn}/\overline{PRn}$ bus during direct flag operation. During polled flag operation the $\overline{PAEn}/\overline{PRn}$ bus is cycled with respect to RCLK and the ESYNC signal is synchronized to RCLK. The \overline{PAE} , \overline{PR} and \overline{OR} outputs are all synchronized to RCLK. During device expansion the EXO and EXI signals are based on RCLK. RCLK must be continuous and free-running.
\overline{RCS} (R10)	Read Chip Select	HSTL-LVTTL INPUT	The \overline{RCS} signal in concert with \overline{REN} signal provides control to enable data on to the output read data bus. During a Master Reset cycle the \overline{RCS} it is don't care signal.
RDADD [7:0] (RDADD7-P16 RDADD6-P15 RDADD5-P14 RDADD4-N16 RDADD3-N15 RDADD2-N14 RDADD1-M16 RDADD0-M15)	Read Address Bus	HSTL-LVTTL INPUT	For the 128Q device the RDADD bus is 8 bits. The RDADD bus is a dual purpose address bus. The first function of RDADD is to select a Queue to be read from. The least significant 7 bits of the bus, RDADD[6:0] are used to address 1 of 128 possible queues within a multi-queue device. The most significant 1-3 bits, RDADD[7] are used to select 1 of 2 possible multi-queue devices that may be connected in expansion mode. An in expansion configuration the MSb will address a device with the matching ID code. The address present on the RDADD bus will be selected on a rising edge of RCLK provided that RADEN is HIGH, (note, that data can be placed on to the Qout bus, read from the previously selected queue on this RCLK edge). Two RCLK rising edges after read queue select, data will be placed on to the Qout outputs from the newly selected queue, regardless of \overline{REN} due to the first word fall through effect. The second function of the RDADD bus is to select the status word of queues to be loaded on to the $\overline{PAEn}/\overline{PRn}$ bus during strobed flag mode. The least significant 4 bits, RDADD[3:0] are used to select the status word of a device to be placed on the \overline{PAEn} bus. The most significant 3 bits, RDADD[7:5] are again used to select 1 of 8 possible multi-queue devices that may be connected in expansion configuration. Address bits RDADD[4] is don't care during status word selection. The status word address present on the RDADD bus will be selected on the rising edge of RCLK provided that ESTR is HIGH, (note, that data can be placed on to the Qout bus, read from the previously selected Queue on this RCLK edge). Please refer to Table 5 for details on RDADD bus.
\overline{REN} (T11)	Read Enable	HSTL-LVTTL INPUT	The \overline{REN} input enables read operations from a selected Queue based on a rising edge of RCLK. In the FWFT mode, a queue to be read from can be selected via RCLK, RADEN and the RDADD address bus regardless of the state of \overline{REN} . A read enable is not required to cycle the $\overline{PAEn}/\overline{PRn}$ bus (in polled mode) or to select the \overline{PAEn} status word, (in direct mode).

PIN DESCRIPTIONS (CONTINUED)

Symbol & (Pin No.)	Name	I/O TYPE	Description
SCLK (N3)	Serial Clock	HSTL-LVTTL INPUT	If serial programming of the multi-queue device has been selected during master reset, the SCLK input clocks the serial data through the multi-queue device. Data setup on the SI input is loaded into the device on the rising edge of SCLK provided that $\overline{\text{SENI}}$ is enabled, LOW. When expansion of devices is performed the SCLK of all devices should be connected to the same source.
$\overline{\text{SENI}}$ (M2)	Serial Input Enable	HSTL-LVTTL INPUT	During serial programming of a multi-queue device, data loaded onto the SI input will be clocked into the part (via a rising edge of SCLK), provided the $\overline{\text{SENI}}$ input of that device is LOW. If multiple devices are cascaded, the $\overline{\text{SENI}}$ input should be connected to the $\overline{\text{SENO}}$ output of the previous device. So when serial loading of a given device is complete, its $\overline{\text{SENO}}$ output goes LOW, allowing the next device in the chain to be programmed ($\overline{\text{SENO}}$ will follow $\overline{\text{SENI}}$ of a given device once that device is programmed). The $\overline{\text{SENI}}$ input of the master device (or single device), should be controlled by the user.
$\overline{\text{SENO}}$ (M1)	Serial Output Enable	HSTL-LVTTL OUTPUT	This output is used to indicate that serial programming or default programming of the multi-queue device has been completed. $\overline{\text{SENO}}$ follows $\overline{\text{SENI}}$ once programming of a device is complete. Therefore, $\overline{\text{SENO}}$ will go LOW after programming provided $\overline{\text{SENI}}$ is LOW, once $\overline{\text{SENI}}$ is taken HIGH again, $\overline{\text{SENO}}$ will also go HIGH. When the $\overline{\text{SENO}}$ output goes LOW, the device is ready to begin normal read/write operations. If multiple devices are cascaded and serial programming of the devices will be used, the $\overline{\text{SENO}}$ output should be connected to the $\overline{\text{SENI}}$ input of the next device in the chain. When serial programming of the first device is complete, $\overline{\text{SENO}}$ will go LOW, thereby taking the $\overline{\text{SENI}}$ input of the next device LOW and so on throughout the chain. When a given device in the chain is fully programmed the $\overline{\text{SENO}}$ output essentially follows the $\overline{\text{SENI}}$ input. The user should monitor the $\overline{\text{SENO}}$ output of the final device in the chain. When this output goes LOW, serial loading of all devices has been completed.
SI (L1)	Serial In	HSTL-LVTTL INPUT	During serial programming this pin is loaded with the serial data that will configure the multi-queue devices. Data present on SI will be loaded on a rising edge of SCLK provided that $\overline{\text{SENI}}$ is LOW. In expansion mode the serial data input is loaded into the first device in a chain. When that device is loaded and its $\overline{\text{SENO}}$ has gone LOW, the data present on SI will be directly output to the SO output. The SO pin of the first device connects to the SI pin of the second and so on. The multi-queue device setup registers are shift registers.
SO (M3)	Serial Out	HSTL-LVTTL OUTPUT	This output is used in expansion configuration and allows serial data to be passed through devices in the chain to complete programming of all devices. The SI of a device connects to SO of the previous device in the chain. The SO of the final device in a chain should not be connected.
TCK ⁽²⁾ (A8)	JTAG Clock	HSTL-LVTTL INPUT	Clock input for JTAG function. One of four terminals required by IEEE Standard 1149.1-1990. Test operations of the device are synchronous to TCK. Data from TMS and TDI are sampled on the rising edge of TCK and outputs change on the falling edge of TCK. If the JTAG function is not used this signal needs to be tied to GND.
TDI ⁽²⁾ (B9)	JTAG Test Data Input	HSTL-LVTTL INPUT	One of four terminals required by IEEE Standard 1149.1-1990. During the JTAG boundary scan operation, test data serially loaded via the TDI on the rising edge of TCK to either the Instruction Register, ID Register and Bypass Register. An internal pull-up resistor forces TDI HIGH if left unconnected.
TDO ⁽²⁾ (A9)	JTAG Test Data Output	HSTL-LVTTL OUTPUT	One of four terminals required by IEEE Standard 1149.1-1990. During the JTAG boundary scan operation, test data serially loaded output via the TDO on the falling edge of TCK from either the Instruction Register, ID Register and Bypass Register. This output is high impedance except when shifting, while in SHIFT-DR and SHIFT-IR controller states.
TMS ⁽²⁾ (B8)	JTAG Mode Select	HSTL-LVTTL INPUT	TMS is a serial input pin. One of four terminals required by IEEE Standard 1149.1-1990. TMS directs the device through its TAP controller states. An internal pull-up resistor forces TMS HIGH if left unconnected.
$\overline{\text{TRST}}$ ⁽²⁾ (C7)	JTAG Reset	HSTL-LVTTL INPUT	$\overline{\text{TRST}}$ is an asynchronous reset pin for the JTAG controller. The JTAG TAP controller does not automatically reset upon power-up, thus it must be reset by either this signal or by setting TMS= HIGH for five TCK cycles. If the TAP controller is not properly reset then the outputs will always be in high-impedance. If the JTAG function is used but the user does not want to use $\overline{\text{TRST}}$, then $\overline{\text{TRST}}$ can be tied with $\overline{\text{MRS}}$ to ensure proper queue operation. If the JTAG function is not used then this signal needs to be tied to GND. An internal pull-up resistor forces $\overline{\text{TRST}}$ HIGH if left unconnected.
WADEN (P4)	Write Address Enable	HSTL-LVTTL INPUT	The WADEN input is used in conjunction with WCLK and the WRADD address bus to select a queue to be written in to. A queue addressed via the WRADD bus is selected on the rising edge of WCLK provided that WADEN is HIGH. WADEN should be asserted (HIGH) only during a queue change cycle(s). WADEN should not be permanently tied HIGH. WADEN cannot be HIGH for the same WCLK cycle as FSTR. Note,

PIN DESCRIPTIONS (CONTINUED)

Symbol & Pin No.	Name	I/O TYPE	Description
WADEN (Continued)	Write Address Enable	HSTL-LVTTL INPUT	that a write queue selection cannot be made, (WADEN must NOT go active) until programming of the part has been completed and \overline{SEN} has gone LOW.
WCLK (T7)	Write Clock	HSTL-LVTTL INPUT	When enabled by \overline{WEN} , the rising edge of WCLK writes data into the selected Queue via the input bus, Din. The Queue to be written to is selected via the WRADD address bus and a rising edge of WCLK while WADEN is HIGH. A rising edge of WCLK in conjunction with FSTR and WRADD will also select the flag status word to be placed on the PAFn bus during direct flag operation. During polled flag operation the PAFn bus is cycled with respect to WCLK and the FSYNC signal is synchronized to WCLK. The PAFn, PAF and FF outputs are all synchronized to WCLK. During device expansion the FXO and FXI signals are based on WCLK. The WCLK must be continuous and free-running.
\overline{WCS} (T8)	Write Chip Select	HSTL-LVTTL INPUT	The \overline{WCS} pin can be regarded as a second \overline{WEN} input, enabling/disabling write operations.
\overline{WEN} (T6)	Write Enable	HSTL-LVTTL INPUT	The \overline{WEN} input enables write operations to a selected Queue based on a rising edge of WCLK. A queue to be written to can be selected via WCLK, WADEN and the WRADD address bus regardless of the state of \overline{WEN} . Data present on Din can be written to a newly selected queue on the second WCLK cycle after queue selection provided that \overline{WEN} is LOW. A write enable is not required to cycle the PAFn bus (in polled mode) or to select the PAFn status word, (in direct mode).
WRADD [7:0] (WRADD7-T1 WRADD6-R1 WRADD5-R2 WRADD4-P1 WRADD3-P2 WRADD2-P3 WRADD1-N1 WRADD0-N2)	Write Address Bus	HSTL-LVTTL INPUT	For the 128Q device the WRADD bus is 8 bits. The WRADD bus is a dual purpose address bus. The first function of WRADD is to select a Queue to be written to. The least significant 7 bits of the bus, WRADD[6:0] are used to address 1 of 128 possible queues within a multi-queue device. In expansion configuration the most significant bit, WRADD[7] are used to select 1 of 2 possible multi-queue devices (dependant on the number of queues addressed) that may be connected in expansion configuration. These MSb will address a device with the matching ID code. The address present on the WRADD bus will be selected on a rising edge of WCLK provided that WADEN is HIGH, (note, that data present on the Din bus can be written into the previously selected queue on this WCLK edge and on the next rising WCLK also, providing that \overline{WEN} is LOW). Two WCLK rising edges after write queue select, data can be written into the newly selected queue. The second function of the WRADD bus is to select the status word of queues to be loaded on to the PAFn bus during strobed flag mode. The least significant 4 bits, WRADD[3:0] are used to select the status word of a device to be placed on the PAFn bus. The most significant 3 bits, WRADD[7:5] are again used to select 1 of 8 possible multi-queue devices that may be connected in expansion configuration. Address bits WRADD[4] is don't care during status word selection. The status word address present on the WRADD bus will be selected on the rising edge of WCLK provided that FSTR is HIGH, (note, that data can be written into the previously selected queue on this WCLK edge). Please refer to Table 4 for details on the WRADD bus.
VDD (See pg. 16)	+1.8V Supply	Power	These are VDD power supply pins and must all be connected to a +1.8V supply rail.
VDDQ (See pg. 16)	O/P Rail Voltage	Power	These pins must be tied to the desired output rail voltage. For LVTTTL I/O these pins must be connected to +2.5V, for HSTL these pins must be connected to +1.5V and for eHSTL these pins must be connected to +1.8V.
GND (See pg. 16)	Ground Pin	Ground	These are Ground pins and must all be connected to the GND supply rail.
Vref (K3)	Reference Voltage	HSTL INPUT	This is a Voltage Reference input and must be connected to a voltage level determined from the table "Recommended DC Operating Conditions". The input provides the reference level for HSTL/eHSTL inputs. For LVTTTL I/O mode this input should be tied to GND.

NOTES:

1. Inputs should not change after Master Reset.
2. These pins are for the JTAG port. Please refer to pages 82-86 and Figures 71-73.

PIN NUMBER TABLE

Symbol	Name	I/O TYPE	Pin Number
D[35:0] Din	Data Input Bus	HSTL-LVTTL INPUT	D35-J3, D(34-32)-H(3-1), D(31-29)-G(3-1), D(28-26)-F(3-1), D(25-23)-E(3-1), D(22-20)-D(3-1), D(19-17)-C(3-1), D(16,15)-B(2,1), D(14-12)-A(1-3), D11-B3, D10-A4, D9-B4, D8-C4, D7-A5, D6-B5, D5-C5, D4-A6, D3-B6, D2-C6, D1-A7, D0-B7
Q[35:0] Qout	Data Output Bus	HSTL-LVTTL OUTPUT	Q(35,34)-J(15,16), Q(33-31)-H(14-16), Q(30-28)-G(14-16), Q(27-25)-F(14-16), Q(24-22)-E(14-16), Q(21,20)-D(15,16), Q19-B16, Q(18,17)-C(16,15), Q16-D14, Q(15,14)-A(16,15), Q13-B15, Q12-A14, Q11-B14, Q10-C14, Q9-A13, Q8-B13, Q7-C13, Q6-A12, Q5-B12, Q4-C12, Q3-A11, Q2-B11, Q(1,0)-C(11,10)
VDD	+1.8V Supply	Power	D(7-10), E(6,7,10,11), F(5,12), G(4,5,12,13), H(4,13), J(4,13), K(4,5,12,13), L(5,12), M(6,7,10,11), N(7-10)
VDDQ	O/P Rail Voltage	Power	D(4-6,11-13), E(4,5,12,13), F(4,13), L(4,13), M(4,5,12,13), N(4-6,11-13)
GND	Ground Pin	Ground	E(8-9), F(6-11), G(6-11), H(5-12), J(1,5-12), K(2,6-11,14), L(6-11), M(8-9)

ABSOLUTE MAXIMUM RATINGS

Symbol	Rating	Commercial	Unit
VTERM	Terminal Voltage with respect to GND	-0.5 to +2.9 ⁽²⁾	V
TSTG	Storage Temperature	-55 to +125	°C
IOUT	DC Output Current	-50 to +50	mA

NOTES:

- Stresses greater than those listed under ABSOLUTE MAXIMUM RATINGS may cause permanent damage to the device. This is a stress rating only and functional operation of the device at these or any other conditions above those indicated in the operational sections of this specification is not implied. Exposure to absolute maximum rating conditions for extended periods may affect reliability.
- Compliant with JEDEC JESD8-5. VDD terminal only.

CAPACITANCE (TA = +25°C, f = 1.0MHz)

Symbol	Parameter ⁽¹⁾	Conditions	Max.	Unit
CIN ^(2,3)	Input Capacitance	VIN = 0V	10 ⁽³⁾	pF
COU ^(1,2)	Output Capacitance	VOUT = 0V	15	pF

NOTES:

- With output deselected, ($\overline{OE} \geq V_{IH}$).
- Characterized values, not currently tested.
- CIN for Vref is 20pF.

RECOMMENDED DC OPERATING CONDITIONS

Symbol	Parameter	Min.	Typ.	Max.	Unit	
VDD	Supply Voltage	1.7	1.8	1.9	V	
VDDO	Output Rail Voltage for I/Os	— LVTTTL	2.375	2.5	2.625	V
		— eHSTL	1.7	1.8	1.9	V
		— HSTL	1.4	1.5	1.6	V
GND	Supply Voltage	0	0	0	V	
VIH ⁽²⁾	Input High Voltage	— LVTTTL	1.7	—	2.625	V
		— eHSTL	VREF+0.2	—	—	V
		— HSTL	VREF+0.2	—	—	V
VIL	Input Low Voltage	— LVTTTL	-0.3	—	0.7	V
		— eHSTL	—	—	VREF-0.2	V
		— HSTL	—	—	VREF-0.2	V
VREF ⁽¹⁾ (HSTL only)	Voltage Reference Input	— eHSTL	0.8	0.9	1.0	V
		— HSTL	0.68	0.75	0.9	V
TA	Operating Temperature Commercial	0	—	70	°C	
TA	Operating Temperature Industrial	-40	—	85	°C	

NOTE:

- VREF is only required for HSTL or eHSTL inputs. VREF should be tied LOW for LVTTTL operation.
- VIH AC Component = VREF + 0.4V

DC ELECTRICAL CHARACTERISTICS

(Commercial: $V_{DD} = 1.8V \pm 0.10V$, $T_A = 0^{\circ}C$ to $+70^{\circ}C$; Industrial: $V_{DD} = 1.8V \pm 0.10V$, $T_A = -40^{\circ}C$ to $+85^{\circ}C$)

Symbol	Parameter	Min.	Max.	Unit	
I _{LI}	Input Leakage Current	-10	10	μA	
I _{LO}	Output Leakage Current	-10	10	μA	
V _{OH} ⁽³⁾	Output Logic "1" Voltage, I _{OH} = -8 mA @V _{DDQ} = 2.5V ± 0.125V (LVTTTL) I _{OH} = -8 mA @V _{DDQ} = 1.8V ± 0.1V (eHSTL) I _{OH} = -8 mA @V _{DDQ} = 1.5V ± 0.1V (HSTL)	V _{DDQ} -0.4 V _{DDQ} -0.4 V _{DDQ} -0.4	— — —	V V V	
V _{OL}	Output Logic "0" Voltage, I _{OL} = 8 mA @V _{DDQ} = 2.5V ± 0.125V (LVTTTL) I _{OL} = 8 mA @V _{DDQ} = 1.8V ± 0.1V (eHSTL) I _{OL} = 8 mA @V _{DDQ} = 1.5V ± 0.1V (HSTL)	— — —	0.4V 0.4V 0.4V	V V V	
I _{DD1} ^(1,2)	Active V _{DD} Current (V _{DD} = 1.8V)	I/O = LVTTTL I/O = HSTL I/O = eHSTL	— — —	80 150 150	mA mA mA
I _{DD2} ^(1,5)	Standby V _{DD} Current (V _{DD} = 1.8V)	I/O = LVTTTL I/O = HSTL I/O = eHSTL	— — —	25 100 100	mA mA mA
I _{DDQ} ^(1,2)	Active V _{DDQ} Current (V _{DDQ} = 2.5V LVTTTL) (V _{DDQ} = 1.5V HSTL) (V _{DDQ} = 1.8V eHSTL)	I/O = LVTTTL I/O = HSTL I/O = eHSTL	— — —	10 10 10	mA mA mA

NOTES:

- Both WCLK and RCLK toggling at 20MHz.
- Data inputs toggling at 10MHz.
- Total Power consumed: $PT = [(V_{DD} \times I_{DD}) + (V_{DDQ} \times I_{DDQ})]$.
- Outputs are not 3.3V tolerant.
- The following inputs should be pulled to GND: WRADD, RDADD, WADEN, FSTR, ESTR, SCLK, SI, EXI, FXI and all Data Inputs.
The following inputs should be pulled to V_{DD}: WEN, REN, SEN, MRS, TDI, TMS and TRST.
All other inputs are don't care and should be at a known state.

HSTL

1.5V AC TEST CONDITIONS

Input Pulse Levels	0.25 to 1.25V
Input Rise/Fall Times	0.4ns
Input Timing Reference Levels	0.75
Output Reference Levels	V _{DDQ} /2

NOTE:

1. V_{DDQ} = 1.5V ± 0.1V.

EXTENDED HSTL

1.8V AC TEST CONDITIONS

Input Pulse Levels	0.4 to 1.4V
Input Rise/Fall Times	0.4ns
Input Timing Reference Levels	0.9
Output Reference Levels	V _{DDQ} /2

NOTE:

1. V_{DDQ} = 1.8V ± 0.1V.

2.5V LVTTTL

2.5V AC TEST CONDITIONS

Input Pulse Levels	GND to 2.5V
Input Rise/Fall Times	1ns
Input Timing Reference Levels	V _{DD} /2
Output Reference Levels	V _{DDQ} /2

NOTE:

1. V_{DDQ} = 2.5V ± 0.125V.

AC TEST LOADS

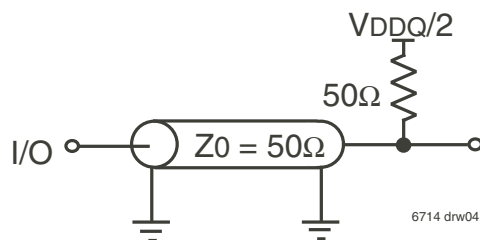

Figure 2a. AC Test Load

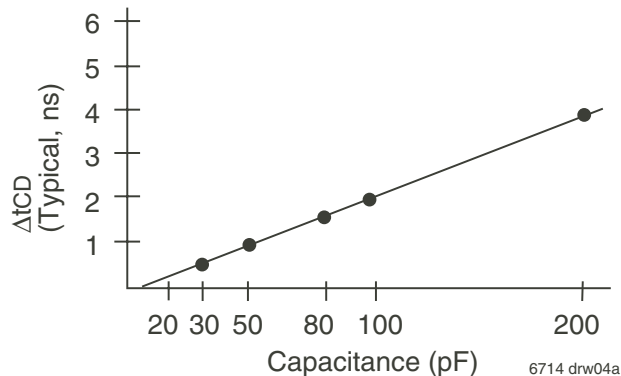
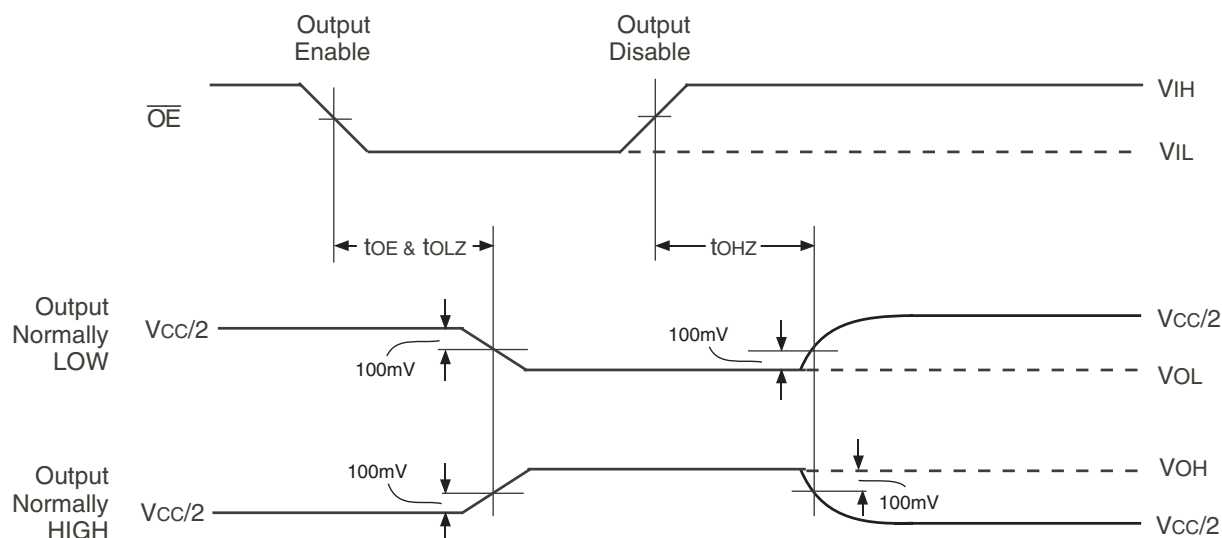

Figure 2b. Lumped Capacitive Load, Typical Derating

OUTPUT ENABLE & DISABLE TIMING



NOTE:

1. REN is HIGH.

6714 drw05

AC ELECTRICAL CHARACTERISTICS

(Commercial: VDD = 1.8V ± 0.10V, TA = 0°C to +70°C; Industrial: VDD = 1.8V ± 0.10V, TA = -40°C to +85°C; JEDEC JESD8-A compliant)

Symbol	Parameter	Commercial		Com'I & Ind'I ⁽¹⁾		Unit		
				IDT72P51749L5	IDT72P51749L6		IDT72P51759L6	IDT72P51769L6
		Min.	Max.	Min.	Max.			
fs	Clock Cycle Frequency (WCLK & RCLK)	—	200	—	166	MHz		
tA	Data Access Time	0.6	3.6	0.6	3.7	ns		
tCLK	Clock Cycle Time	5	—	6	—	ns		
tCLKH	Clock High Time	2.25	—	2.7	—	ns		
tCLKL	Clock Low Time	2.25	—	2.7	—	ns		
tDS	Data Setup Time	1.5	—	2.0	—	ns		
tDH	Data Hold Time	0.5	—	0.5	—	ns		
tENS	Enable Setup Time	1.5	—	2.0	—	ns		
tENH	Enable Hold Time	0.5	—	0.5	—	ns		
tRS	Reset Pulse Width	30	—	30	—	ns		
tRSS	Reset Setup Time	15	—	15	—	ns		
tRSF	Reset Output Status	—	10	—	10	ns		
tRSR	Reset Recovery Time	10	—	10	—	ns		
tOLZ ($\overline{OE-Q_n}$) ⁽²⁾	Output Enable to Output in Low-Impedance	0.6	3.6	0.6	3.7	ns		
tOHZ ⁽²⁾	Output Enable to Output in High-Impedance	0.6	3.6	0.6	3.7	ns		
tOE	Output Enable to Data Output Ready	0.6	3.6	0.6	3.7	ns		
fc	Clock Cycle Frequency (SCLK)	—	10	—	10	MHz		
tSCLK	Serial Clock Cycle	100	—	100	—	ns		
tSCKH	Serial Clock High	45	—	45	—	ns		
tSCKL	Serial Clock Low	45	—	45	—	ns		
tSDS	Serial Data In Setup	20	—	20	—	ns		
tSDH	Serial Data In Hold	1.2	—	1.2	—	ns		
tSENS	Serial Enable Setup	20	—	20	—	ns		
tSENH	Serial Enable Hold	1.2	—	1.2	—	ns		
tSDO	SCLK to Serial Data Out	—	20	—	20	ns		
tSENO	SCLK to Serial Enable Out	—	20	—	20	ns		
tSDOP	Serial Data Out Propagation Delay	0.6	3.7	0.6	3.7	ns		
tSENOP	Serial Enable Propagation Delay	0.6	3.7	0.6	3.7	ns		
tPCSF	Programming Complete to Status Flag	—	7+1 SCLK	—	7+1 SCLK	clock cycles		
tAS	Address Setup	1.5	—	2.0	—	ns		
tAH	Address Hold	0.5	—	0.5	—	ns		
tWFF	Write Clock to Full Flag	—	3.6	—	3.7	ns		
tREF	Read Clock to Empty Flag	—	3.6	—	3.7	ns		
tSTS	$\overline{PAE}/\overline{PAF}$ Strobe Setup	1.5	—	1.5	—	ns		
tSTH	$\overline{PAE}/\overline{PAF}$ Strobe Hold	0.5	—	0.5	—	ns		
tQS	Queue Setup	1.5	—	2.0	—	ns		
tQH	Queue Hold	0.5	—	0.5	—	ns		
tWAF	WCLK to \overline{PAF} flag	0.6	3.6	0.6	3.7	ns		
tRAE	RCLK to \overline{PAE} flag	0.6	3.6	0.6	3.7	ns		
tPAF	Write Clock to Synchronous Almost-Full Flag Bus	0.6	3.6	0.6	3.7	ns		
tPAE	Read Clock to Synchronous Almost-Empty Flag Bus	0.6	3.6	0.6	3.7	ns		
tPAELZ ⁽²⁾	RCLK to \overline{PAE} Flag Bus to Low-Impedance	0.6	3.6	0.6	3.7	ns		
tPAEHZ ⁽²⁾	RCLK to \overline{PAE} Flag Bus to High-Impedance	0.6	3.6	0.6	3.7	ns		

NOTES:

- Industrial temperature range product for the 6ns is available as a standard device. All other speed grades available by special order.
- Values guaranteed by design, not currently tested.

AC ELECTRICAL CHARACTERISTICS (CONTINUED)

(Commercial: VDD = 1.8V ± 0.10V, TA = 0°C to +70°C; Industrial: VDD = 1.8V ± 0.10V, TA = -40°C to +85°C; JEDEC JESD8-A compliant)

Symbol	Parameter	Commercial		Com'I & Ind'I ⁽¹⁾		Unit
		IDT72P51749L5 IDT72P51759L5 IDT72P51769L5		IDT72P51749L6 IDT72P51759L6 IDT72P51769L6		
		Min.	Max.	Min.	Max.	
tPAFLZ ⁽²⁾	WCLK to $\overline{\text{PAF}}$ Flag Bus to Low-Impedance	0.6	3.6	0.6	3.7	ns
tPAFHZ ⁽²⁾	WCLK to $\overline{\text{PAF}}$ Flag Bus to High-Impedance	0.6	3.6	0.6	3.7	ns
tFFHZ ⁽²⁾	WCLK to Full Flag/Input Ready to High-Impedance	0.6	3.6	0.6	3.7	ns
tFFLZ ⁽²⁾	WCLK to Full Flag/Input Ready to Low-Impedance	0.6	3.6	0.6	3.7	ns
tEFLZ ⁽²⁾	RCLK to Empty Flag/Output Ready Flag to Low-Impedance	0.6	3.6	0.6	3.7	ns
tEFHZ ⁽²⁾	RCLK to Empty Flag/Output Ready Flag to High-Impedance	0.6	3.6	0.6	3.7	ns
tFSYNC	WCLK to $\overline{\text{PAF}}$ Bus Sync to Output	0.6	3.6	0.6	3.7	ns
tFXO	WCLK to $\overline{\text{PAF}}$ Bus Expansion to Output	0.6	3.6	0.6	3.7	ns
tESYNC	RCLK to $\overline{\text{PAE}}$ Bus Sync to Output	0.6	3.6	0.6	3.7	ns
tEXO	RCLK to $\overline{\text{PAE}}$ Bus Expansion to Output	0.6	3.6	0.6	3.7	ns
tPR	RCLK to Packet Ready Flag	0.6	3.6	0.6	3.7	ns
tSKEW1	SKEW time between RCLK and WCLK for $\overline{\text{FF}}/\overline{\text{IR}}$ and $\overline{\text{EF}}/\overline{\text{OR}}$	5	—	6	—	ns
tSKEW2	SKEW time between RCLK and WCLK for $\overline{\text{PAF}}$ and $\overline{\text{PAE}}$	5	—	6	—	ns
tSKEW3	SKEW time between RCLK and WCLK for $\overline{\text{PAF}}[0:7]$ and $\overline{\text{PAE}}[0:7]$	5	—	6	—	ns
tSKEW4	SKEW time between RCLK and WCLK for $\overline{\text{PR}}$ and $\overline{\text{EF}}/\overline{\text{OR}}$	5	—	6	—	ns
tXIS	Expansion Input Setup	1.5	—	2.0	—	ns
tXIH	Expansion Input Hold	0.5	—	0.5	—	ns
tPPMS	Parallel Programming Setup	15	—	15	—	ns
tPPMH	Parallel Programming Hold	5	—	5	—	ns

NOTES:

1. Industrial temperature range product for the 6ns is available as a standard device. All other speed grades available by special order.
2. Values guaranteed by design, not currently tested.

FUNCTIONAL DESCRIPTION

MASTER RESET

A Master Reset is performed by toggling the \overline{MRS} input from HIGH to LOW to HIGH. During a master reset all internal multi-queue device setup and control registers are initialized and require programming either serially by the user via the serial port, or via parallel programming or by using the default settings. Refer to Figure 4, *Device Programming Hierarchy* for the programming hierarchy structure. During a master reset the state of the following inputs determine the functionality of the part, these pins should be held HIGH or LOW.

- PKT – Packet Mode
- FM – Flag bus Mode
- BM [3:0] – Bus Matching options
- MAST – Master Device
- ID0, 1, 2 – Device ID

DFM – Programming mode, serial or default

DF – Offset value for \overline{PAE} and \overline{PAF}

Once a master reset has taken place, the device must be programmed either serially or via the default method before any read/write operations can begin.

See Figure 37, *Master Reset* for relevant timing.

PROGRAMMING MODE CAPTURED

On the rising of \overline{MRS} the programming mode signals (QSEL 0 & 1, DEFAULT) are captured. Once the programming mode signals are captured (latched), refer to Table 1 for details. It will then require a number of clock cycles for the device to complete the configuration. Configuration completion is indicated when the $\overline{SEN0}$ signal transitions from high to low. The configuration completion indication is consistent with the previous MQ device.

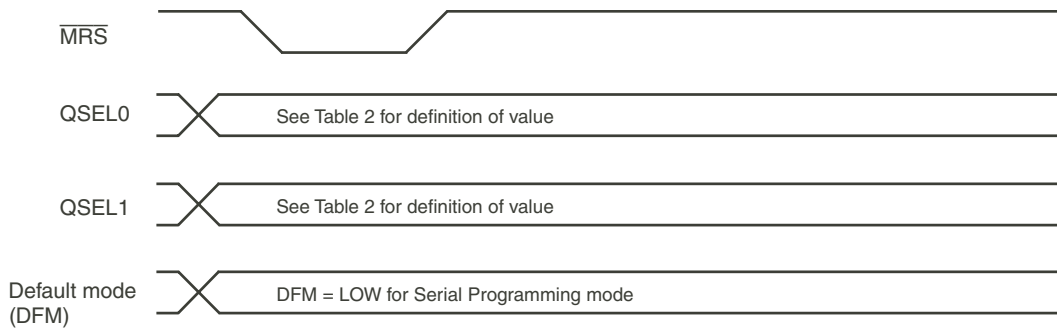

6714 drw06

Figure 3. Reference Signals

TABLE 1 — DEVICE PROGRAMMING MODE COMPARISON

Programmable Parameter	Serial Programming	Parallel Programming	Default Programming
Number of Queues	Any number from 1 to 128	Any number from 1 to 128	64 or 128
Queue Depth	Each queue depth can be individualized	The total memory is evenly divided across the queues	The total memory is evenly divided across the queues
$\overline{PAE}/\overline{PAF}$ Offset Value	Programmable to any value	Fixed value	Fixed value
Bus Matching	Any combination of x9 or x18 or x36 can be selected using the BM[3:0] bits.	Any combination of x9 or x18 or x36 can be selected using the BM[3:0] bits.	Any combination of x9, x18, or x36 can be selected using the BM[3:0] bits
I/O voltage	LVTTL, eHSTL, HSTL	LVTTL, eHSTL, HSTL	LVTTL, eHSTL, HSTL

TABLE 2 — SETTING THE QUEUE PROGRAMMING MODE DURING MASTER RESET

\overline{MRS}	Default Mode (DFM)	QSEL 1	QSEL 0	Queue Programming Method
↑	0	0	0	RESERVED
↑	0	0	1	RESERVED
↑	0	1	0	RESERVED
↑	0	1	1	Serial programming mode
↑	1	0	0	Enables the user to program the number of Queues using the Write Address bus
↑	1	0	1	Enables the user to program the number of Queues using the Read Address bus
↑	1	1	0	Selects 64 Queue
↑	1	1	1	Selects 128 Queue

6714 drw07

SERIAL PROGRAMMING

The multi-queue flow-control device is a fully programmable device, providing the user with flexibility in how queues are configured in terms of the number of queues, depth of each queue and position of the $\overline{\text{PAE}}/\overline{\text{PAF}}$ flags within respective queues. All user programming is done via the serial port after a master reset has taken place. Internally the multi-queue device has setup registers which must be serially loaded, these registers contain values for every queue within the device, such as the depth and $\overline{\text{PAE}}/\overline{\text{PAF}}$ offset values. The IDT72P51749/72P51759/72P51769 devices are capable of up to 128 queues and therefore contain 128 sets of registers for the setup of each queue.

During a Master Reset if the DFM (Default Mode) input is LOW, then the device will require serial programming by the user. It is recommended that the user utilize a 'C' program provided by IDT, this program will prompt the user for all information regarding the multi-queue setup. The program will then generate a serial bit stream which should be serially loaded into the device via the serial port. For the IDT72P51749/72P51759/72P51769 devices the serial programming requires a total number of serially loaded bits per device, (SCLK cycles with $\overline{\text{SEN}}_1$ enabled), calculated by: $19 + (Q \times 72)$ where Q is the number of queues the user wishes to setup within the device.

Once the master reset is complete and $\overline{\text{MRS}}$ is HIGH, the device can be serially loaded. Data present on the SI (serial in), input is loaded into the serial port on a rising edge of SCLK (serial clock), provided that $\overline{\text{SEN}}_1$ (serial in enable), is LOW. Once serial programming of the device has been successfully completed the device will indicate this via the $\overline{\text{SEN}}_0$ (serial output enable) going active, LOW. Upon detection of completion of programming, the user should cease all programming and take $\overline{\text{SEN}}_1$ inactive, HIGH. Note, $\overline{\text{SEN}}_0$ follows $\overline{\text{SEN}}_1$ once programming of a device is complete. Therefore, $\overline{\text{SEN}}_0$ will go LOW after programming provided $\overline{\text{SEN}}_1$ is LOW, once $\overline{\text{SEN}}_1$ is taken HIGH again, $\overline{\text{SEN}}_0$ will also go HIGH. The operation of the SO output is similar, when programming of a given device is complete, the SO output will follow the SI input.

If devices are being used in expansion configuration the serial ports of devices should be cascaded. The user can load all devices via the serial input port control pins, SI & $\overline{\text{SEN}}_1$, of the first device in the chain. Again, the user may utilize the 'C' program to generate the serial bit stream, the program prompting the user for the number of devices to be programmed. The $\overline{\text{SEN}}_0$ and SO (serial out) of the first device should be connected to the $\overline{\text{SEN}}_1$ and SI inputs of the second device respectively and so on, with the $\overline{\text{SEN}}_0$ & SO outputs connecting to the $\overline{\text{SEN}}_1$ & SI inputs of all devices through the chain. All devices in the chain should be connected to a common SCLK. The serial output port of the final device should be monitored by the user. When $\overline{\text{SEN}}_0$ of the final device goes LOW, this indicates that serial programming of all devices has been successfully completed. Upon detection of completion of programming, the user should cease all programming and take $\overline{\text{SEN}}_1$ of the first device in the chain inactive, HIGH.

As mentioned, the first device in the chain has its serial input port controlled by the user, this is the first device to have its internal registers serially loaded by the serial bit stream. When programming of this device is complete it will take its $\overline{\text{SEN}}_0$ output LOW and bypass the serial data loaded on the SI input to its SO output. The serial input of the second device in the chain is now loaded with the data from the SO of the first device, while the second device has its $\overline{\text{SEN}}_1$ input LOW. This process continues through the chain until all devices are programmed and the $\overline{\text{SEN}}_0$ of the final device (or master device, ID = '000') goes LOW.

Once all serial programming has been successfully completed, normal operations, (queue selections on the read and write ports) may begin. When connected in expansion configuration, the IDT72P51749/72P51759/72P51769 devices require a total number of serially loaded bits per device to complete serial programming, (SCLK cycles with $\overline{\text{SEN}}_1$ enabled), calculated by: $n[19 + (Q \times 72)]$ where Q is the number of queues the user wishes to setup within the device, where n is the number of devices in the chain.

See Figure 42, *Serial Port Connection* and Figure 43, *Serial Programming* for connection and timing information.

DEFAULT PROGRAMMING

During a Master Reset if the DFM (Default Mode) input is HIGH the multi-queue device will be configured for default programming, (serial programming is not permitted). Default programming provides the user with a simpler, however limited means to setup the multi-queue flow-control device, rather than using the serial programming method. The default mode will configure a multi-queue device with the maximum number of queues setup, and the available memory allocated equally between the queues. The values of the $\overline{\text{PAE}}/\overline{\text{PAF}}$ offsets is determined by the state of the DF (default) pin during a master reset.

For the IDT72P51749/72P51759/72P51769 devices the default mode will setup 128 queues, each queue being 256 x 36, 512 x 36, and 1024 x 36 deep respectively. For each device, the value of the $\overline{\text{PAE}}/\overline{\text{PAF}}$ offsets is determined at master reset by the state of the DF input. If DF is LOW then both the $\overline{\text{PAE}}$ & $\overline{\text{PAF}}$ offset will be 8, if HIGH then the value is 128.

When configuring the IDT72P51749/72P51759/72P51769 devices in default mode the user simply has to apply WCLK cycles after a master reset, until $\overline{\text{SEN}}_0$ goes LOW, this signals that default programming is complete. These clock cycles are required for the device to load its internal setup registers. When a single multi-queue device is used, the completion of device programming is signaled by the $\overline{\text{SEN}}_0$ output of a device going from HIGH to LOW. Note, that $\overline{\text{SEN}}_1$ must be held LOW when a device is setup for default programming mode.

When multi-queue devices are connected in expansion configuration, the $\overline{\text{SEN}}_1$ of the first device in a chain can be held LOW. The $\overline{\text{SEN}}_0$ of a device should connect to the $\overline{\text{SEN}}_1$ of the next device in the chain. The $\overline{\text{SEN}}_0$ of the final device is used to indicate that default programming of all devices is complete. When the master (ID = '000') $\overline{\text{SEN}}_0$ goes LOW normal operations may begin. Again, all devices will be programmed with their maximum number of queues and the memory divided equally between them. Please refer to Figure 38, *Default Programming*.

PARALLEL PROGRAMMING

During a Master Reset cycle (i.e. the $\overline{\text{MRS}}$ signal transitions from HIGH to LOW then LOW to HIGH) if the DFM (Default Mode) input signal is HIGH and the QSEL 1 input signal is LOW the Multi-Queue Flow Control device is configured for Parallel Programming. Parallel Programming enables the number of queues within the device to be set through either the Write Address (WRADD) bus or Read Address (RDADD) bus after the Master Reset cycle. Within Parallel Programming mode the Multi-Queue (MQ) device programmable parameters are; number of queues, queue depth, $\overline{\text{PAE}}/\overline{\text{PAF}}$ flag offset value, bus matching and the I/O voltage level. As previously indicated, the number of queues are configured using the write or read address bus, however bus matching is set during the Master Reset cycle. The value that is set during the Master Reset cycle is determined by the Bus Matching (BM) bits. For the IDT72P51749/72P51759/72P51769 devices in Parallel Programming Mode the value of the $\overline{\text{PAE}}/\overline{\text{PAF}}$ offsets at master reset is determined by the state of the DF input. If DF is LOW then both the $\overline{\text{PAE}}$ & $\overline{\text{PAF}}$ offset will be 8, if HIGH then the value is 128.

When configuring the IDT72P51749/72P51759/72P51769 devices in Parallel Programming Mode the user simply has to apply WCLK cycles after a master reset, until $\overline{\text{SEN}}_0$ goes LOW, this signals that Parallel Programming is complete. These clock cycles are required for the device to load its internal setup registers. When a single multi-queue device is used, the completion of device programming is signaled by the $\overline{\text{SEN}}_0$ output of a device going from HIGH to LOW. Note, that $\overline{\text{SEN}}_1$ must be held LOW when a device is setup for Parallel Programming mode.

When Multi-Queue devices are connected in an Expansion Configuration, the $\overline{SEN1}$ signal of the first device in a chain must be held LOW. The $\overline{SEN0}$ signal of a device should connect to the $\overline{SEN1}$ of the next device in the chain. The $\overline{SEN0}$ of the final device is used to indicate that the programming of all devices is complete. When the master device (ID='000') $\overline{SEN0}$ signal goes LOW the internal programming is complete and queue write/read operation may begin. Please refer to Figure 39, *Parallel Programming* for signal timing details.

PROGRAMMING HIERARCHY

Configuring the device is a 2 stage sequence. The first stage is to set the expansion device type, the desired programming mode and the device operating mode during the master reset cycle (i.e. on the rising edge of Master Reset (MRS)). The second stage is to set values such as PAE/PAF, number of queues, queue depth, etc. using the programming mode (serial, parallel, default) selected in stage 1. Refer to Figure 4, *Device Programming Hierarchy*.

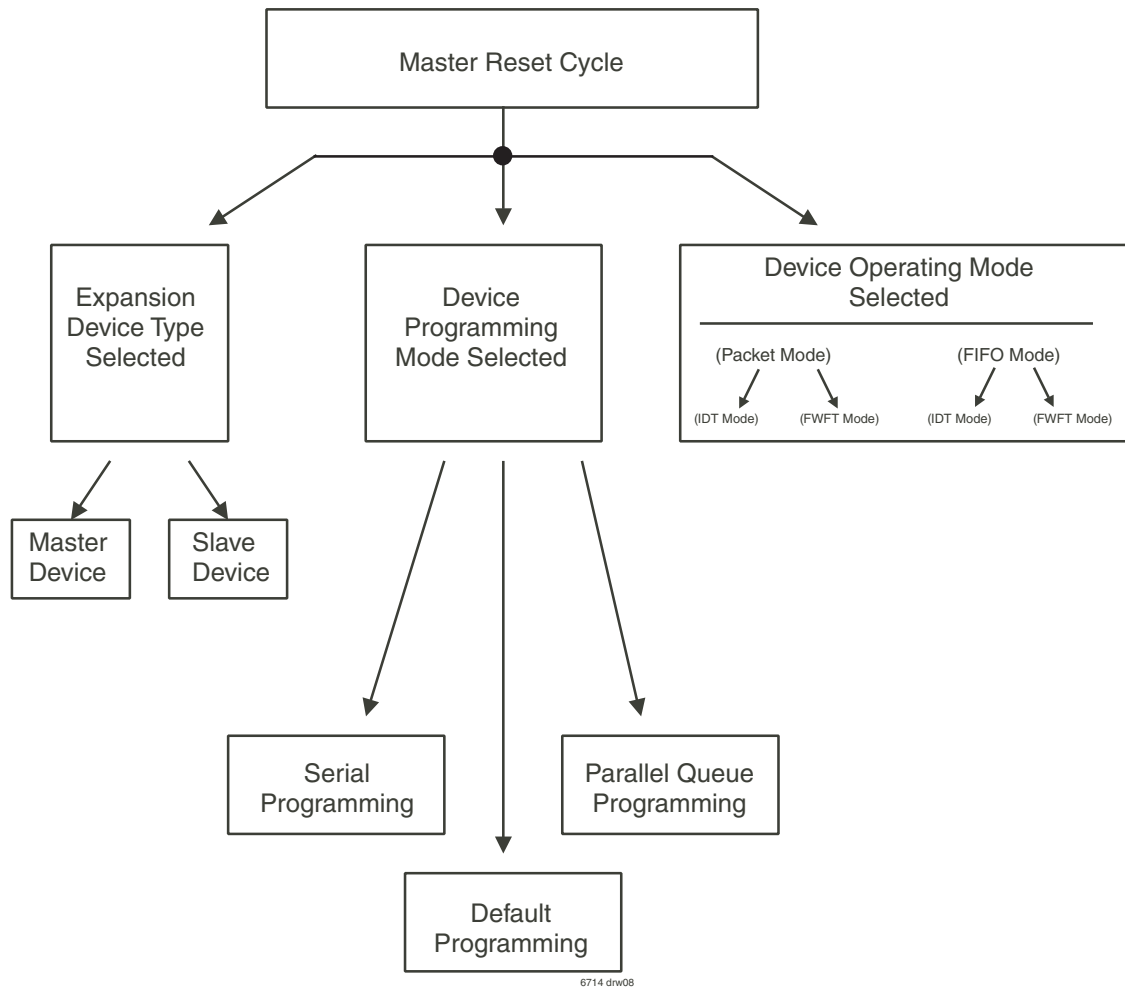
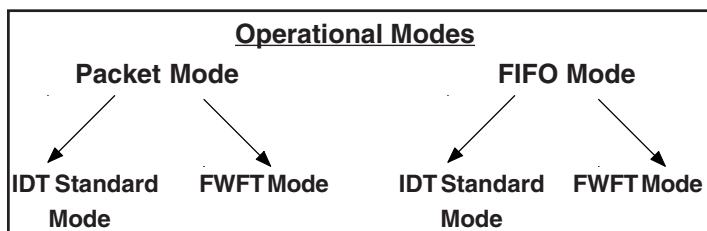

Figure 4. Device Programming Hierarchy

QUEUE DESCRIPTION

CONFIGURATION OF THE IDT MULTI-QUEUE FLOW-CONTROL DEVICE

The IDT72P51749/72P51759/72P51769 multi-queue flow-control devices can be configured in distinct modes, namely Packet mode, FIFO mode, Standard



mode, and FWFT mode. To configure the device operational mode set the configuration pins (PKT, FWFT) as indicated in Table 3, Mode Configuration.

TABLE 3 — MODE CONFIGURATION

Configuration Signals		Modes
PKT	FWFT	
LOW	LOW	FIFO mode - IDT Standard Mode
LOW	HIGH	FIFO mode - FWFT
HIGH	LOW	Packet mode - IDT Standard Mode
HIGH	HIGH	Packet mode - FWFT

In IDT Standard mode the read port signal $\overline{EF}/\overline{OR}$ is configured for empty flag (\overline{EF}) signaling. \overline{EF} is an active LOW signal. When \overline{EF} is LOW it signifies the selected (present) queue is empty. On the write port, signal $\overline{FF}/\overline{IR}$ is configured

for full flag (\overline{FF}) signaling. \overline{FF} is an active LOW signal. When \overline{FF} is LOW it signifies the selected (present) queue is full. Refer to Figure 5, *IDT Standard mode illustrated (Read Port)*.

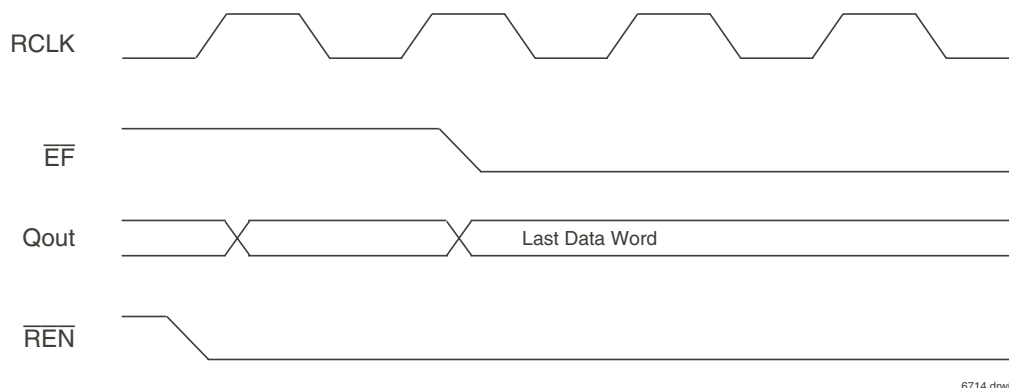

Figure 5. IDT Standard mode illustrated (Read Port)

In FWFT mode the read port signal $\overline{EF}/\overline{OR}$ is configured for output ready (\overline{OR}) signaling. \overline{OR} is an active LOW signal. When \overline{OR} is HIGH, it signifies there is no available word to read. On the write port, signal $\overline{FF}/\overline{IR}$ is configured for input

ready (\overline{IR}) signaling. \overline{IR} is an active LOW signal. When \overline{IR} is LOW it signifies the write port is ready for writing into the selected queue. Refer to Figure 6, *FWFT mode illustrated (Read Port)*.

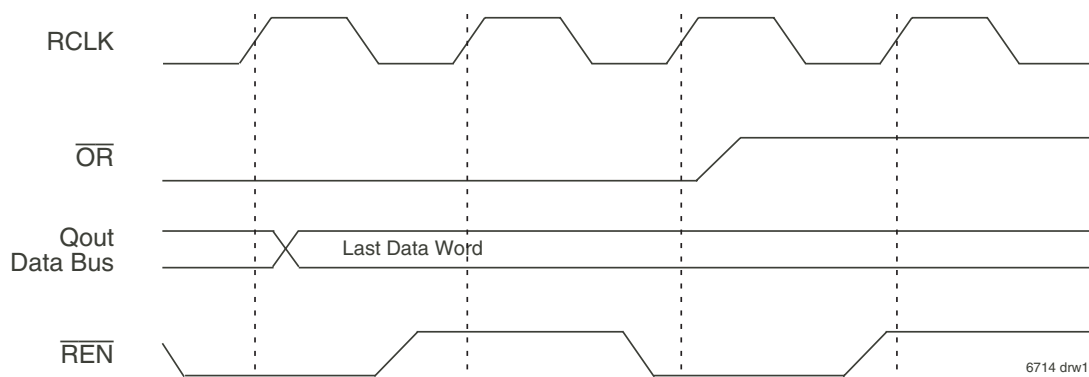

Figure 6. First Word Fall Through (FWFT) mode illustrated (Read Port)

STANDARD MODE OPERATION

WRITE QUEUE SELECTION AND WRITE OPERATION
(STANDARD MODE)

The IDT72P51749/72P51759/72P51769 multi-queue flow-control devices can be configured up to a maximum of 128 queues which data can be written via a common write port using the data inputs (Din), write clock (WCLK) and write enable (WEN). The queue to be written is selected by the address present on the write address bus (WRADD) during a rising edge on WCLK while write address enable (WADEN) is HIGH. The state of WEN does not impact the queue selection. The queue selection requires 4 WCLK cycle. All subsequent data writes will be to this queue until another queue is selected.

Standard mode operation is defined as individual words will be written to the device as opposed to Packet Mode where complete packets are written. The write port is designed such that 100% bus utilization can be obtained. This means that data can be written into the device on every WCLK rising edge including the cycle that a new queue is being addressed.

Changing queues requires 4 WCLK cycles on the write port (see Figure 44, *Write Queue Select, Write Operation and Full flag Operation*). WADEN goes high signaling a change of queue (clock cycle "A"). The address on WRADD at that time determines the next queue. Data presented during each cycle, will be written to the active queue, provided WEN is LOW. If WEN is HIGH (inactive), data will not be written in a queue. The write port discrete full flag will update to show the full status of the newly selected queue. Data present on the data input bus (Din), can be written into the newly selected queue on the rising edge of WCLK a change of queue, provided WEN is LOW and the queue is not full. If the selected queue is full at the point of its selection, any writes to that queue will be prevented. Data cannot be written into a full queue.

Refer to Figure 44, *Write Queue Select, Write Operation and Full flag Operation*, Figure 46, *Write Operations in First Word Fall Through* for timing diagrams and Figure 47, *Full Flag Timing in Expansion Configuration* for timing diagrams.

TABLE 4 — WRITE ADDRESS BUS, WRADD[7:0]

Operation	WCLK	WADEN	FSTR	WRADD[7:0]									
Write Queue Select		1	0	7	6	5	4	3	2	1	0	Device Select (Compared to ID2,1,0)	Write Queue Address (6 bits = 64 Queues, 7 bits = 128 Queues)
$\overline{\text{PAFn}}$ Quadrant Select		0	1	7	6	5	4	3	2	1	0	Device Select (Compared to ID2,1,0)	X Status Word Address

Status Word Address	Queue Status on $\overline{\text{PAFn}}$ Bus
0000	Q0 : Q7 → $\overline{\text{PAF0}}$: $\overline{\text{PAF7}}$
0001	Q8 : Q15 → $\overline{\text{PAF0}}$: $\overline{\text{PAF7}}$
0010	Q16 : Q23 → $\overline{\text{PAF0}}$: $\overline{\text{PAF7}}$
0011	Q24 : Q31 → $\overline{\text{PAF0}}$: $\overline{\text{PAF7}}$
0100	Q32 : Q39 → $\overline{\text{PAF0}}$: $\overline{\text{PAF7}}$
0101	Q40 : Q47 → $\overline{\text{PAF0}}$: $\overline{\text{PAF7}}$
0110	Q48 : Q55 → $\overline{\text{PAF0}}$: $\overline{\text{PAF7}}$
0111	Q56 : Q63 → $\overline{\text{PAF0}}$: $\overline{\text{PAF7}}$
1000	Q64 : Q71 → $\overline{\text{PAF0}}$: $\overline{\text{PAF7}}$
1001	Q72 : Q79 → $\overline{\text{PAF0}}$: $\overline{\text{PAF7}}$
1010	Q80 : Q87 → $\overline{\text{PAF0}}$: $\overline{\text{PAF7}}$
1011	Q88 : Q95 → $\overline{\text{PAF0}}$: $\overline{\text{PAF7}}$
1100	Q96 : Q103 → $\overline{\text{PAF0}}$: $\overline{\text{PAF7}}$
1101	Q104 : Q111 → $\overline{\text{PAF0}}$: $\overline{\text{PAF7}}$
1110	Q112 : Q119 → $\overline{\text{PAF0}}$: $\overline{\text{PAF7}}$
1111	Q120 : Q127 → $\overline{\text{PAF0}}$: $\overline{\text{PAF7}}$

6714 dnr11

**READ QUEUE SELECTION AND READ OPERATION
(STANDARD MODE)**

The IDT72P51749/72P51759/72P51769 multi-queue flow-control devices can be configured up to a maximum of 128 queues which data can be read via a common read port using the data outputs (Qout), read clock (RCLK) and read enable (REN). An output enable, OE control pin is also provided to allow High-Impedance selection of the Qout data outputs. The multi-queue device read port operates in standard IDT mode and "First Word Fall Through" mode (see Figure 46, *Write Operations in First Word Fall Through*). The queue to be read is selected by the address presented on the read address bus (RDADD) during a rising edge on RCLK while read address enable (RADEN) is HIGH. The state of REN does not impact the queue selection. The queue selection requires 4 RCLK cycles. All subsequent data reads will be from this queue until another queue is selected.

Standard mode operation is defined as individual words will be read from the device. The read port is designed such that 100% bus utilization can be

obtained. This means that data can be read out of the device on every RCLK rising edge including the cycle that a new queue is being addressed.

Changing queues requires a minimum of four RCLK cycles on the read port (see Figure 48, *Read Queue Select, Read Operation*). RADEN goes high signaling a change of queue (clock cycle "D"). The address on RDADD at that time determines the next queue. Data presented during that cycle will be read. Reading data can continue from the active, provided REN is LOW. If REN is HIGH (inactive) for these two clock cycles, data will not be read from the queue. If a new selected queue is empty, any reads from that queue will be prevented. Data cannot be read from an empty queue. Remember that OE allows the user to place the data output bus (Qout) into High-Impedance and the data can be read in to the output register regardless of OE.

Refer to Table 5, for Read Address Bus arrangement. Also, refer to Figures 13, 15, and 16 for read queue selection and read port operation timing diagrams.

TABLE 5 — READ ADDRESS BUS, RDADD[7:0]

Operation	RCLK	RADEN	ESTR	RDADD[7:0]							
Read Queue Select		1	0	7	6	5	4	3	2	1	0
				Device Select (Compared to ID2,1,0)			Read Queue Address (6 bits = 64 Queues 7 bits = 128 Queues)				
PAEn/PRn Quadrant Select		0	1	7	6	5	4	3	2	1	0
				Device Select (Compared to ID2,1,0)			X	Status Word Address			

Status Word Address	Queue Status on PAEn/PRn Bus
0000	Q0 : Q7 → PAF0 : PAF7
0001	Q8 : Q15 → PAF0 : PAF7
0010	Q16 : Q23 → PAF0 : PAF7
0011	Q24 : Q31 → PAF0 : PAF7
0100	Q32 : Q39 → PAF0 : PAF7
0101	Q40 : Q47 → PAF0 : PAF7
0110	Q48 : Q55 → PAF0 : PAF7
0111	Q56 : Q63 → PAF0 : PAF7
1000	Q64 : Q71 → PAF0 : PAF7
1001	Q72 : Q79 → PAF0 : PAF7
1010	Q80 : Q87 → PAF0 : PAF7
1011	Q88 : Q95 → PAF0 : PAF7
1100	Q96 : Q103 → PAF0 : PAF7
1101	Q104 : Q111 → PAF0 : PAF7
1110	Q112 : Q119 → PAF0 : PAF7
1111	Q120 : Q127 → PAF0 : PAF7

6714 dnr12

PACKET MODE OPERATION

The Packet mode operation provides the capability where, user defined packets or frames can be written to the device as opposed to Standard mode where individual words are written. For clarification, in Packet Mode, a packet can be written to the device with the starting location designated as Transmit Start of Packet (TSOP) and the ending location designated as Transmit End of Packet (TEOP). In conjunction, a packet read from the device will be designated as Receive Start of Packet (RSOP) and a Receive End of Packet (REOP). The minimum size for a packet is four words (SOP, two words of data and EOP). The 4 words must be the largest word that is configured. For example in a x18 to x9 bus matching configuration the four words must be x18 bit words. The almost empty flag bus becomes the "Packet Ready" \overline{PR} flag bus when the device is configured for packet mode. Valid packets are indicated when both \overline{PR} and \overline{OR} are asserted.

WRITE QUEUE SELECTION AND WRITE OPERATION (PACKET MODE)

Changing queues requires 4 WCLK cycles on the write port (see Figure 54, *Writing in Packet Mode during a Queue Change*). WADEN goes high signaling a change of queue (clock cycle "B" or "I"). The address on WRADD at the rising edge of WCLK determines the next queue. Data presented on Din during that cycle ("B" or "I") and the next cycle ("C" or "J") can continue to be written to the active (old) queue (Q_A or Q_B respectively), provided \overline{WEN} is LOW (active). If \overline{WEN} is HIGH (inactive) for these two clock cycles (H), data will not be written in to the previous queue (Q_A). The write port discrete full flag will update to show the full status of the newly selected queue (Q_B) at this last cycle's rising edge ("D" or "K"). Data values presented on the data input bus (Din), can be written into the newly selected queue (Q_x) on the rising edge of WCLK on the third cycle ("E") following a request for change of queue, provided \overline{WEN} is LOW (active) and the new queue is not full. If a selected queue is full (\overline{FF} is LOW), then writes to that queue will be prevented. Note, data cannot be written into a full queue.

Refer to Figure 54, *Writing in Packet Mode during a Queue Change* for timing diagrams.

READ QUEUE SELECTION AND READ OPERATION (PACKET MODE)

Changing queues requires 4 RCLK cycles on the read port (see Figure 55, *Reading in Packet Mode during a Queue Change*). RADEN goes high signaling a change of queue (clock cycle "B" or "I"). The address on RDADD at the rising edge of RCLK determines the queue. As illustrated in Figure 55 during cycle ("B" or "I"), and the next cycle ("C" or "J") data can continue to be read from the active (old) queue (Q_A or Q_B respectively), provided both \overline{REN} and \overline{OE} are LOW (active) simultaneously with changing queues. In applications where the multi-queue flow-control device is connected to a shared bus, an output enable, \overline{OE} control pin is also provided to allow High-Impedance selection of the data outputs (Qout).

Refer to Figure 55, *Reading in Packet Mode during a Queue Change* as well as Figure 38, 39, 40, 41, and 42 for timing diagrams and Table 5, for Read Address bus arrangement.

Note, the almost empty flag bus becomes the "Packet Ready" flag bus when the device is configured for packet ready mode.

EXPANDING QUEUES OR PROVIDING DEEPER QUEUES

Expansion can take place only in IDT Standard mode. In the 128 queue multi-queue device, the WRADD address bus is 8 bits wide. The 7 Least Significant bits (LSBs) are used to address one of the 128 available queues within a single multi-queue device. The Most Significant bit (MSb) is used when a device is connected in expansion configuration, each device having its own bit 7 address. When logically expanded with multiple parts, each device is statically setup with a unique chip ID code on the ID pins, ID0, ID1, and ID2. A device is selected when the Most Significant bit of the WRADD address bus matches the ID code.

Note: The WRADD bus is also used in conjunction with FSTR (almost full flag bus strobe), to address the almost full flag bus during direct mode of operation.

Refer to Table 4, for Write Address bus arrangement. Also, refer to Figure 47, *Full Flag Timing Expansion Configuration*, Figure 51, *Output Ready Flag Timing (In Expansion Configuration)*, and Figure 67, *Connecting two 4MMQ 128Q devices in Expansion Mode*, for timing diagrams.

SWITCHING QUEUES ON THE WRITE PORT

The IDT72P51749/72P51759/72P51769 multi-queue flow-control devices can be configured up to a maximum of 128 queues. Data is written into a queue using the Data Input (Din) bus, Write Clock (WCLK) and Write Enable (\overline{WEN}) signals. Selecting a queue occurs by placing the queue address on the Write

Address bus (WRADD) during a rising edge of WCLK while Write Address Enable (WADEN) is HIGH. For reference, the state of Write Enable (\overline{WEN}) is a "Don't Care" during a queue selection. \overline{WEN} has significance during the queue mark operation. Selecting a queue requires 4 WCLK cycles. Refer to Figure 7, *Write Port Switching Queues Signal Sequence*.

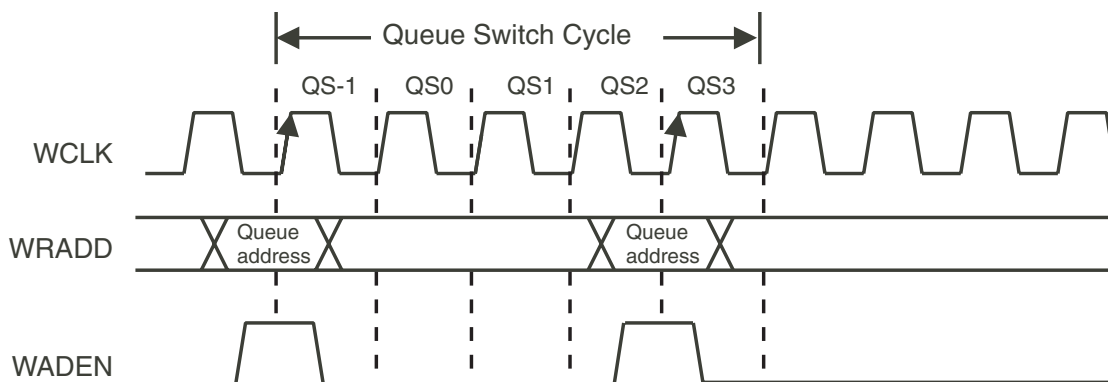

6714 drw13

Figure 7. Write Port Switching Queues Signal Sequence

The IDT72P51749/72P51759/72P51769 multi-queue flow-control device supports changing (switching) queues every four (4) clock cycles. To switch from the Present Queue (PQ) to another queue requires a queue address to be placed on the Write Address Bus (WRADD) bus and a rising edge of Write Clock (WCLK) and Write Address Enable (WADEN) is HIGH. There are no restrictions as to the order to which queues are selected or switched into or out of.

For maximum efficiency, during the 4 clock cycles required to switch queues the IDT72P51749/72P51759/72P51769 multi-queue flow-control device can continue to write into the Present Queue (PQ). The Present Queue is defined as the current selected queue. Refer to Figure 8, *Switching Queues Bus Efficiency*.

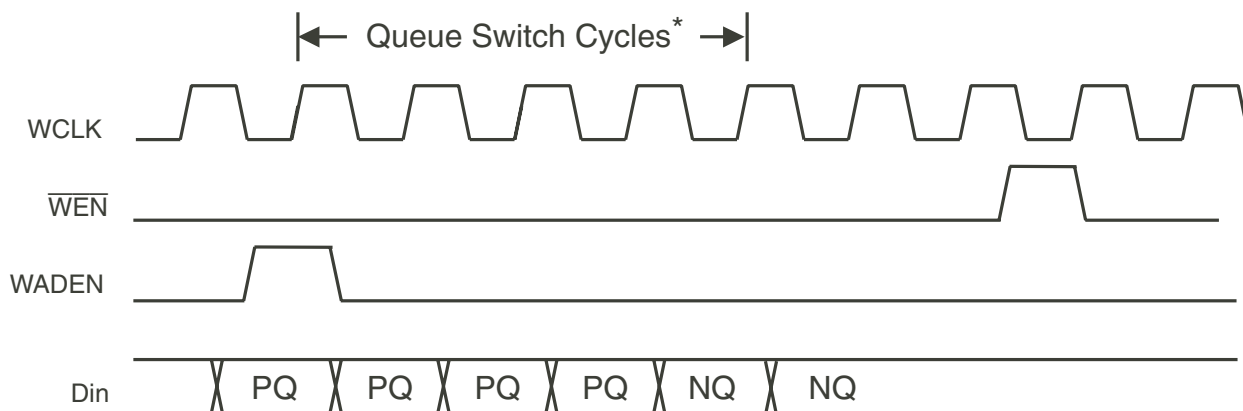

6714 drw14

NOTES:

- 1. PQ = Present Queue
- NQ = Next Queue
- * Requires 4 clock cycles to switch queues.

Figure 8. Switching Queues Bus Efficiency

The IDT72P51749/72P51759/72P51769 multi-queue flow-control device supports writing and reading from either the same queue or from different queues. The device also supports simultaneous queue switching on the write

and read ports. The simultaneous queue switching may occur with either the Write Clock and Read Clock synchronous or asynchronous to each other. For reference refer to Figure 9, *Simultaneous Queue Switching*.

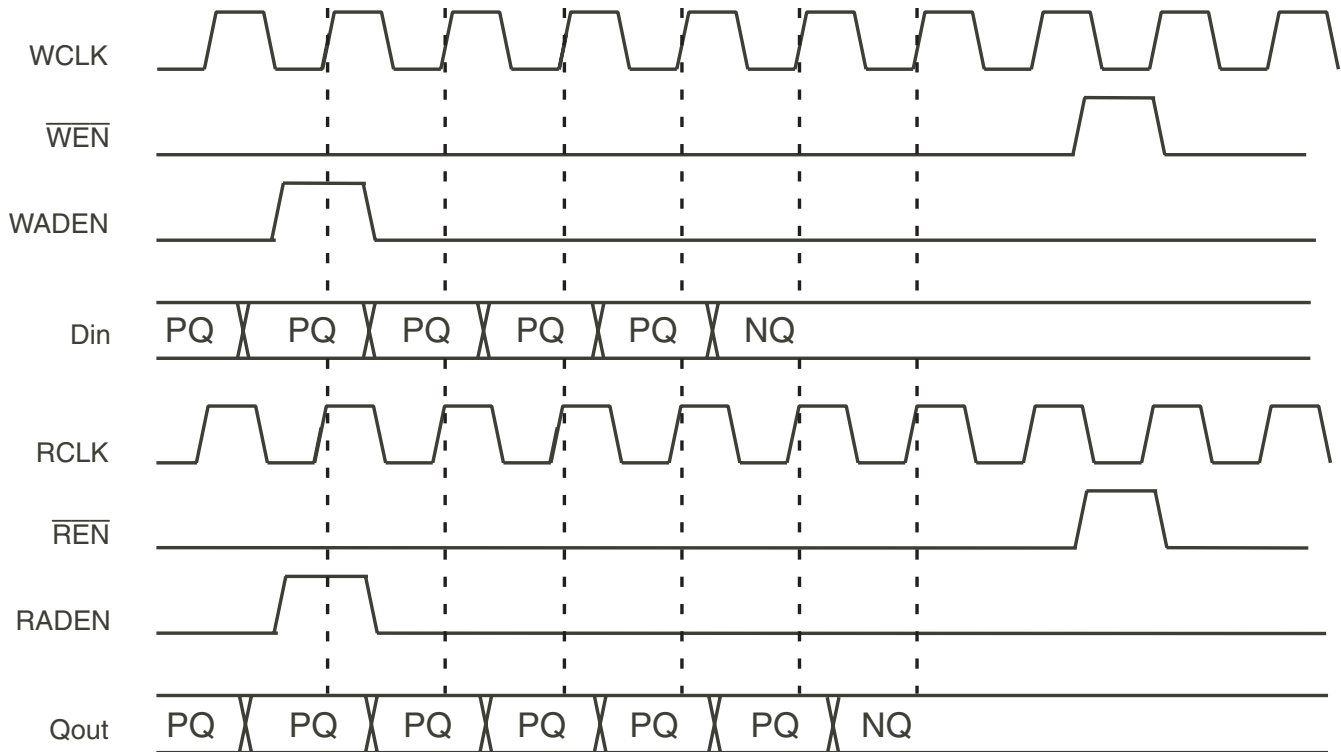

6714 drw15

Figure 9. Simultaneous Queue Switching

The multi-queue flow-control device requires 4 clock cycles to switch queues on the write port. Refer to Table 6, Write Queue Switch Operation for a detailed description of each queue switch clock cycle.

TABLE 6 — WRITE QUEUE SWITCH OPERATION

Queue Switch Cycle	IDT Mode	FWFT Mode
QS-1	Queue Switch Initiated, Rewrite/No Rewrite selection	Queue Switch Initiated, Rewrite/No Rewrite selection
QS0	Queue MARK / Un-MARK	Queue MARK / Un-MARK
QS1	—	—
QS2	<ul style="list-style-type: none"> • PAF signal updated for Next Queue (NQ) • Packet Ready (PR) signal updated • Full Flag (FF) updated for NQ 	<ul style="list-style-type: none"> • PAF signal updated for Next Queue (NQ) • Packet Ready (PR) signal updated • IR flag updated for NQ
QS3	Start of Write Data Operation	Start of Write Data Operation

SWITCHING QUEUES ON THE READ PORT

The IDT72P51749/72P51759/72P51769 multi-queue flow-control devices can be configured up to a maximum of 128 queues. Data is read from a queue using the Data Output (Qout) bus, Read Clock (RCLK) and Read Enable (REN) signals. Selecting a queue on the read port occurs by placing the queue address on the Read Address bus (RDADD) during a rising edge of RCLK while Read

Address Enable (RADEN) is HIGH. For reference, the state of Read Enable (REN) is a "Don't Care" during a read port queue selection. REN has significance during the queue mark operation. Selecting a queue requires 4 WCLK cycles. Refer to Figure 10, *Read Port Switching Queues Signal Sequence*.

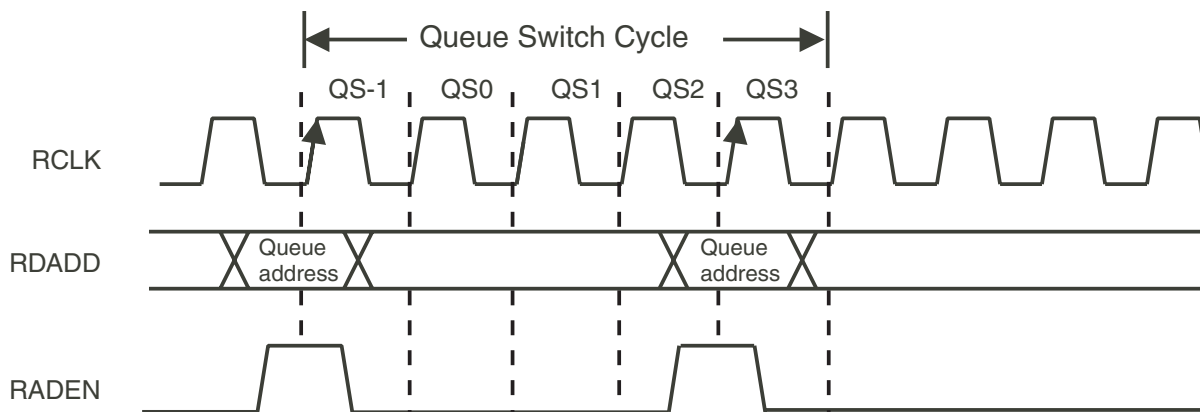

6714 drw16

Figure 10. Read Port Switching Queues Signal Sequence

The IDT72P51749/72P51759/72P51769 multi-queue flow-control device supports changing (switching) queues every four (4) clock cycles. To switch from the Present Queue (PQ) to another queue requires a queue address to be placed on the Read Address Bus (RDADD) bus and a rising edge of Read Clock (RCLK) and Read Address Enable (RADEN) is HIGH. There are no restrictions as to the order to which queues are selected or switched into or out of.

For maximum efficiency, during the 4 clock cycles required to switch queues the IDT72P51749/72P51759/72P51769 multi-queue flow-control device can continue to read from the Present Queue (PQ). The Present Queue is defined as the current selected queue. Refer to Figure 11. *Switching Queues Bus Efficiency*.

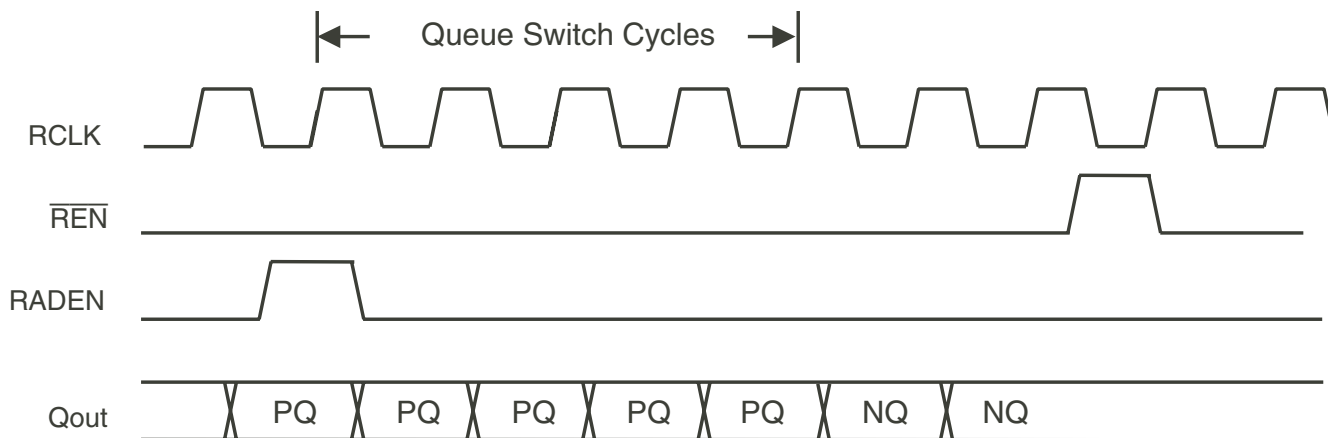

6714 drw17

NOTE:
PQ = Present Queue
NQ = Next Queue

Figure 11. Switching Queues Bus Efficiency

SIMULTANEOUS QUEUE SWITCHING

The IDT72P51749/72P51759/72P51769 multi-queue flow-control device supports reading and writing from either the same queue or from different queues. The device also supports simultaneous queue switching on the read

and write ports. The simultaneous queue switching may occur with either the Read Clock and Write Clock synchronous or asynchronous to each other. For reference refer to Figure 12, *Simultaneous Queue Switching*.

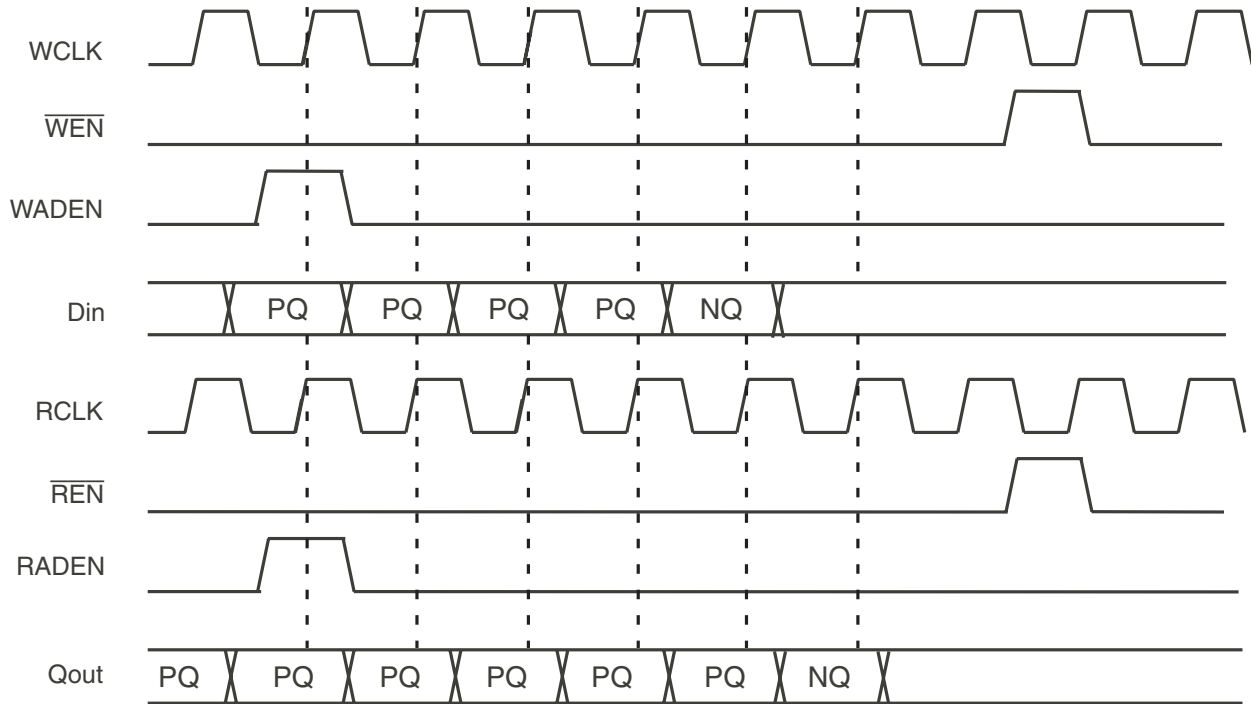

Figure 12. Simultaneous Queue Switching

6714 drw18

The multi-queue flow-control device requires 4 clock cycles to switch queues on the read port, refer to Table 7, Read Queue Switch Operation for a detailed description of each queue switch clock cycles.

TABLE 7 — READ QUEUE SWITCH OPERATION

Queue Switch Cycle	IDT Mode	FWFT Mode
QS-1	Queue Switch Initiated, Re-read/No Re-read selection	Queue Switch Initiated, Re-read/No Re-read selection
QS0	Queue MARK / Un-MARK	Queue MARK / Un-MARK
QS1	—	—
QS2	<ul style="list-style-type: none"> • \overline{PAE} signal updated for Next Queue (NQ) • Packet Ready (\overline{PR}) signal updated • Empty Flag (\overline{EF}) updated for NQ 	<ul style="list-style-type: none"> • \overline{PAE} signal updated for Next Queue (NQ) • Packet Ready (\overline{PR}) signal updated
QS3	Start of Read Data Operation	<ul style="list-style-type: none"> • Start of Read Data Operation • \overline{OR} updated for NQ

TABLE 8 — SAME QUEUE SWITCH

PQ	NQ	Supported	Comment
Not Marked	Not Marked	Yes	Queue Switch is ignored
Not Marked	Marked	Yes	Add Mark to current queue
Marked	Not Marked, No Reread	Not Allowed	
Marked	Not Marked, Reread	Yes	Remove Mark
Marked	Marked, No Reread	Not Allowed	
Marked	Marked, Reread	Yes	Keep Mark

Legend:
PQ = Present Queue
NQ = Next Queue

QUEUE MARKing

The overall intent of the MARK function is to provide the ability to either re-write and/or re-read information that is stored into a queue.

A queue can be MARKed by either the write port or the read port. The MARK operation is port independent. The same queue can be marked by the write port and the read port simultaneously. Only the active queue can be MARKed, multiple queues can NOT be MARKed by a port. A port (write or read) may only designate one queue MARKed at a time. Upon a queue switch a decision must be made as to whether to return to the Marked location or the last access address.

MARK AND REWRITE/ MARK AND REREAD

The MARK functionality operates in any mode combination (Packet mode, IDT Standard Mode, FIFO Mode, FWFT Mode), FWFT). Queues on the Write Port are MARKed using the WCLK & WADEN signals. Queues on the Read Port are MARKed using the RCLK and RADEN signals. Refer to the following timing diagrams for additional queue MARK details. Refer to Figure 13 through 18 for further information.

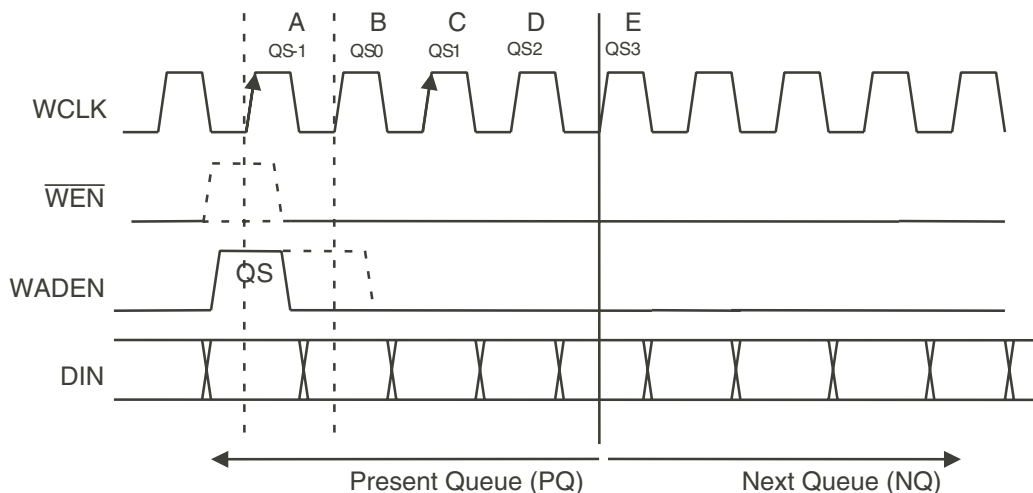

6714 drw29

- @QS-1, if $\overline{WEN}=0$ and $WADEN=1$, PQ will be updated in QS0,1, and 2, and NQ data will be written in QS3.
- @QS-1, if $\overline{WEN}_N=1$ and $WADEN=1$, there is no update for PQ during QS0-QS2. Next time PQ is switched back, data will be written into last update location (rewrite).
- @QS0, WADEN status is used to determine if a "mark" is requested for NQ. If $WADEN=1$ in QS0, NQ will be marked. In FIFO mode, the first NQ position after QS is marked (latch WFCR values before QS3), data can't be read out beyond this location. In packet mode, every SOP position is marked till next SOP comes, then the mark moves to new position.
- @QS0, if $WADEN=0$, NQ is not marked.

Figure 13. MARK and Re-Write Sequence

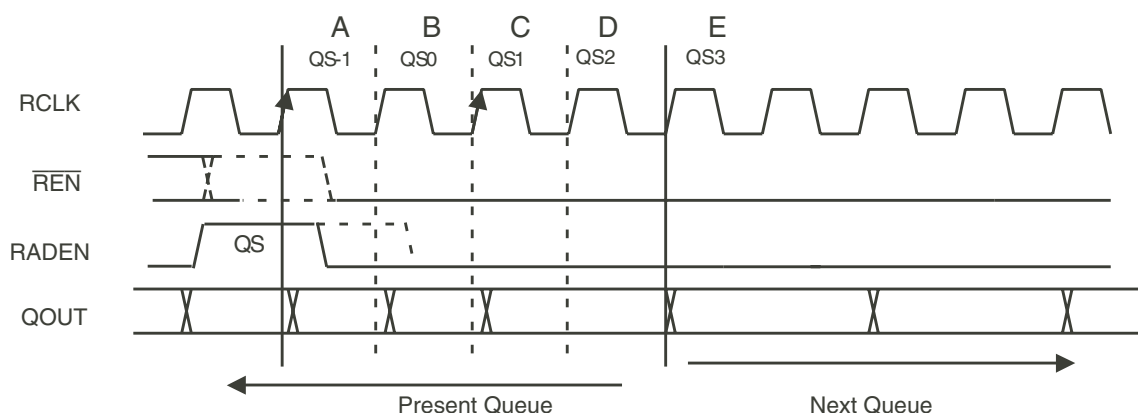

6714 drw30

- @QS-1 (A), if $\overline{REN}=0$ and $RADEN=1$, (request for a Queue Switch occurs $RADEN=1$ and simultaneously reading from a queue) the Queue Address Register will be updated in QS2, and the data from the Next Queue (NQ) will be available in QS3.
- @QS-1, if $\overline{REN}=1$ and $RADEN=1$, (request for a Queue Switch occurs $RADEN=1$) the Queue Address Register will be updated in QS2. The Present Queue address pointer will not increment during QS0-QS2. The Next time PQ is selected, the data will be from the last addressed location.
- @QS0, RADEN status is used to determine if a "mark" is requested for NQ. If $RADEN=1$ in QS0, NQ will be mark. In FIFO mode, first NQ position after QS is marked (latch RFCR values before QS3), data can't overwrite this location. In packet mode, every SOP position is marked till next SOP comes, then the mark moves to new position.

Figure 14. MARK and Re-Read Sequence

Write Queue MARK

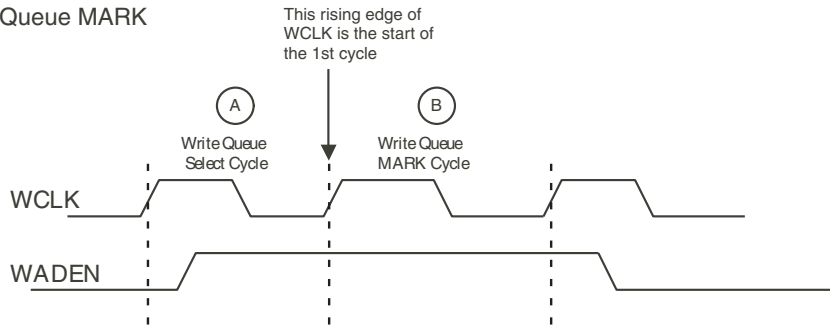

WADEN		ACTION
(A)	(B)	
1	1	Selects a Queue & MARK the Queue
1	0	Selects a Queue

6714 drw31

Figure 15. MARKing a Queue in Packet Mode - Write Queue MARK

Read Queue MARK

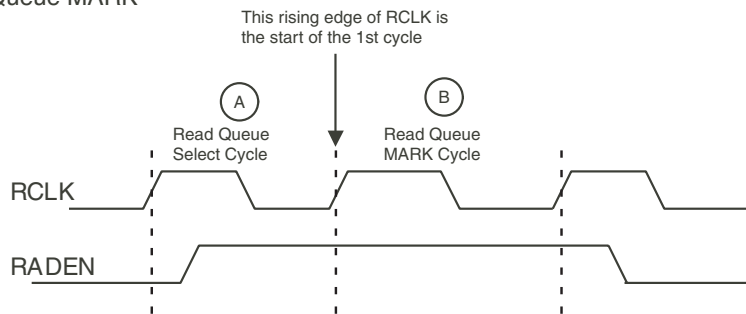

RADEN		ACTION
(A)	(B)	
1	1	Selects a Queue & MARK the Queue
1	0	Selects a Queue

6714 drw32

Figure 16. MARKing a Queue in Packet Mode - Read Queue MARK

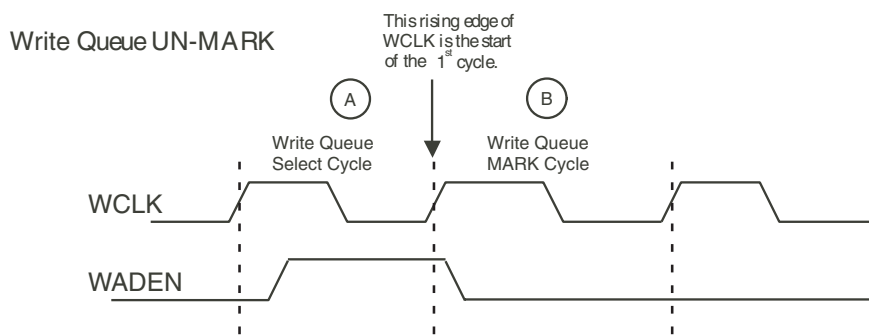

WADEN		ACTION
(A)	(B)	
1	1	Selects a Queue and MARK the Queue
1	0	Selects a Queue and Remove MARK

6714 drw33

Figure 17. UN-MARKing a Queue in Packet Mode - Write Queue UN-MARK

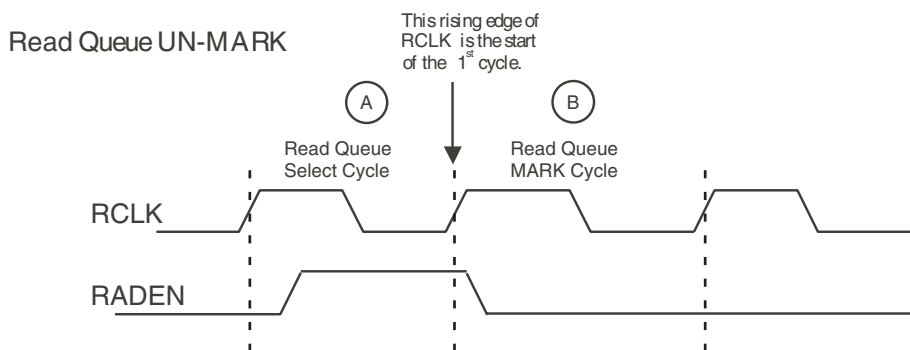

RADEN		ACTION
(A)	(B)	
1	1	Selects a Queue and MARK the Queue
1	0	Selects a Queue & Remove MARK

6714 drw34

Figure 18. UN-MARKing a Queue in Packet Mode - Read Queue UN-MARK

MARK OPERATIONAL NOTES: IN PACKET MODE

Write Port

- MARKing a location can only occur during a Queue switch cycle
- There is only one MARKed location within a Queue
- Only 1 packet can be MARKed at a time within a Queue.
- In packet mode, for a full packet re-write the MARK must occur at the SOP location of the packet.
- In packet mode data can be re-written from the MARK
- In packet mode the MARK moves from packet to packet within a queue when the next packet is written.
- The sequence to move the MARK to the next packet is, first an EOP must occur, then a valid write occurs.

MARK Move Sequence



6714 drwX35

Read Port

- MARKing can only occur during a Queue switch cycle
- Only 1 packet can be MARKed at a time within a Queue.
- In packet mode, MARK is moved to a location of the packet.
- In packet mode the MARK can be moved from SOP (start of packet) to SOP (start of packet) within the queue by a valid read.

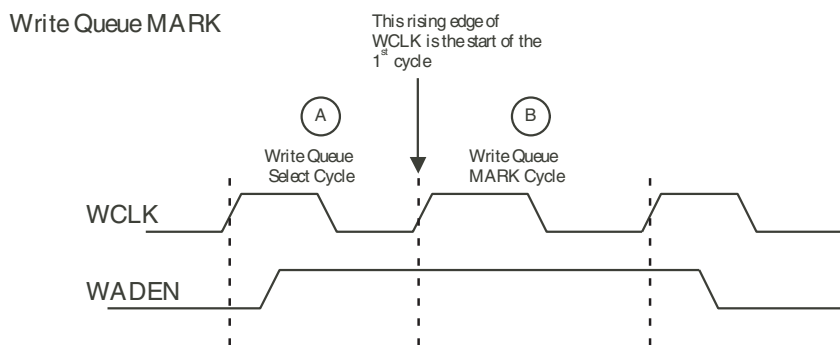

WADEN		ACTION
(A)	(B)	
1	1	Selects the Queue and MARK the Queue
1	0	Selects a Queue

6714 drw36

Figure 19. MARKing a Queue in FIFO Mode - Write Queue MARK

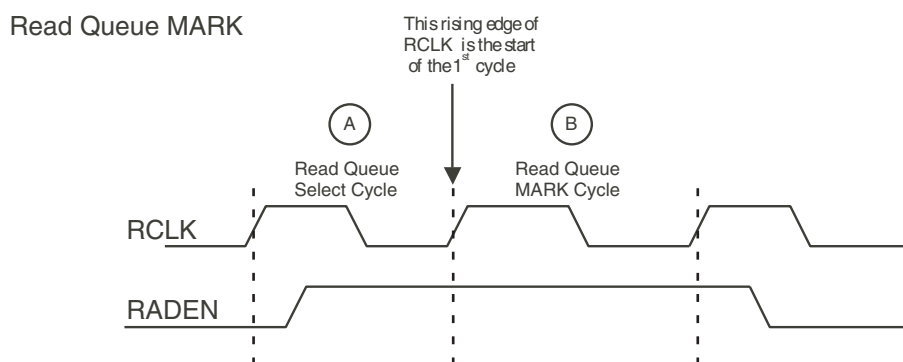

RADEN		ACTION
(A)	(B)	
1	1	Selects the Queue and MARK the Queue
1	0	Selects a Queue

6714 drw37

Figure 20. MARKing a Queue in FIFO Mode - Read Queue MARK

MARK Operational Notes:

In FIFO Mode

Write Port

- MARKing can only occur during a Queue switch cycle
- The entire Queue is MARKed at a time.
- In IDT Standard/FWFT mode, MARK is used to mark the first location of the Queue.
- In IDT Standard/FWFT mode the MARK can NOT be moved within the queue.

Read Port

- MARKing can only occur during a Queue switch cycle
- Only the first location of the Queue can be MARKed in Standard /FWFT mode.
- In IDT Standard mode the MARK can NOT be moved location to location within the queue.

Un-MARKing a Queue

UN-MARKing a Queue in FIFO Mode

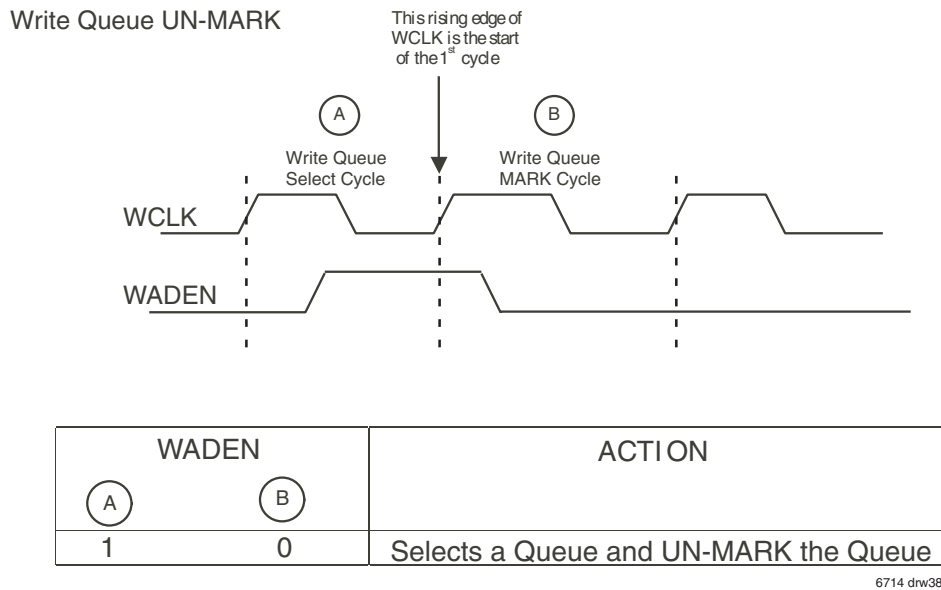

Figure 21. UN-MARKing a Queue in FIFO Mode - Write Queue UN-MARK

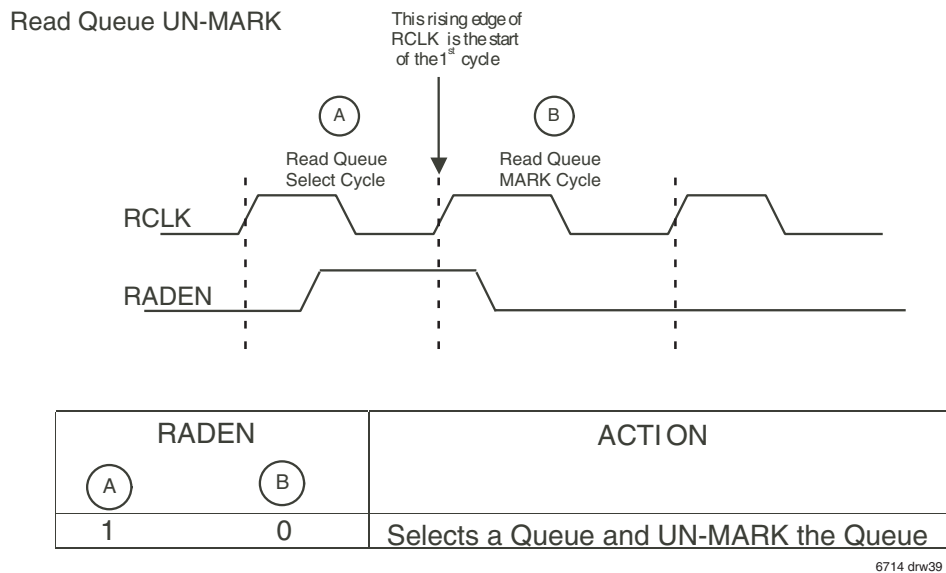

Figure 22. UN-MARKing a Queue in FIFO Mode - Read Queue UN-MARK

UN-MARK Operational Notes:

In FIFO Mode

WritePort

- Un-MARKing can only occur during a Queue switch cycle.
- In FIFO Mode, UN-MARKing a Queue can be accomplished by either switching to the same queue or switching to another queue.
- Note only 1 queue can be marked at any given time.
- In Standard/FIFO mode the MARK can NOT be moved location to location within the queue.

ReadPort

- Un-MARKing can only occur during a Queue switch cycle.
- In Standard/FIFO mode, UN-MARKing a Queue can be accomplished by either switching to the same queue or switching to another queue.
- Note only 1 queue can be marked at any given time.
- In Standard/FIFO mode the MARK can NOT be moved location to location within the queue.

Leaving a MARK Active

During a Queue switch the value of \overline{WEN} for the write port and \overline{REN} for the read port determines whether the MARK remains active or is de-activated.

Leaving a MARK active on the Write Port

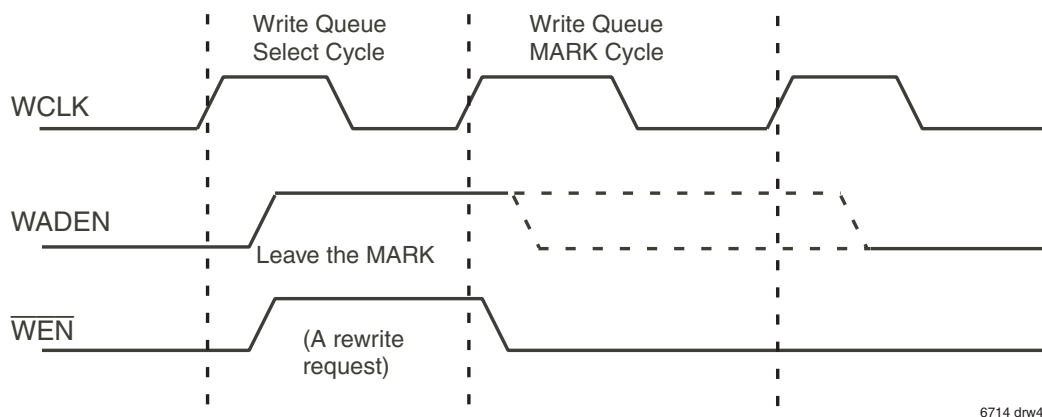

6714 drw40

Figure 23. Leaving a MARK active on the Write Port

Leaving a MARK active on the Read Port

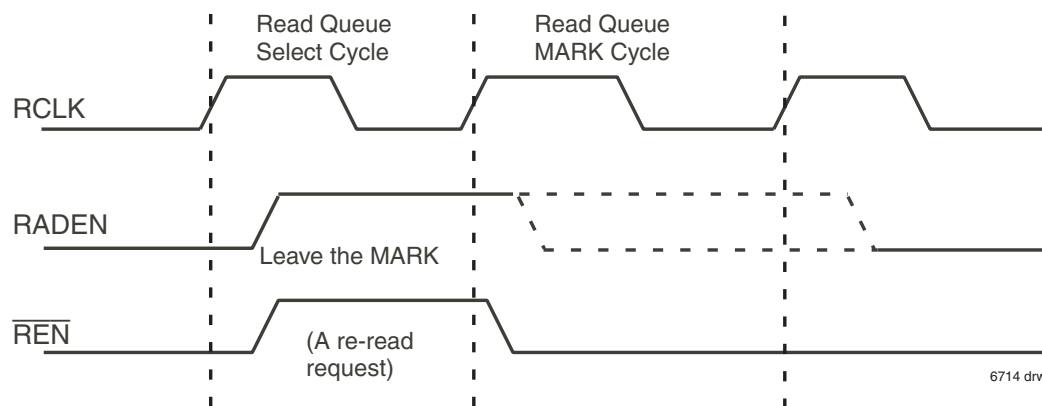

6714 drw41

Figure 24. Leaving a MARK active on the Read Port

Inactivating a MARK

During a Queue switch the value of \overline{WEN} for the write port and \overline{REN} for the read port determines whether the MARK remains active or is de-activated.

Inactivating a MARK on the Write Port

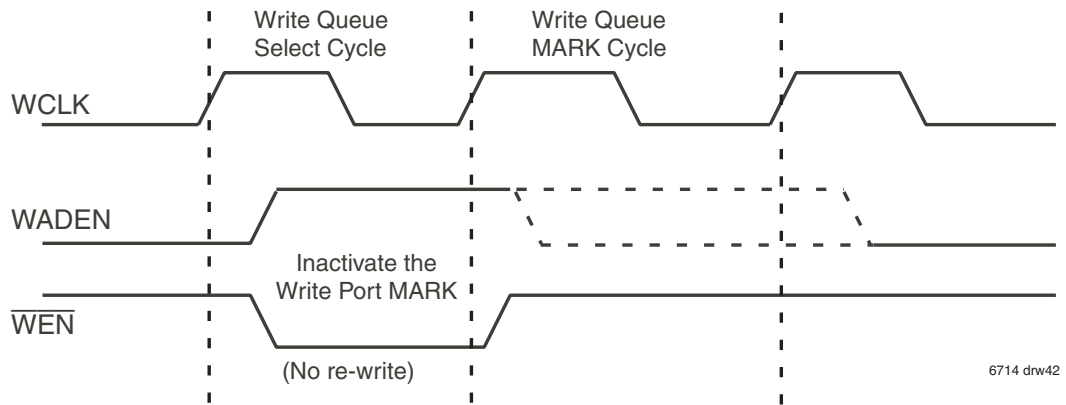

Figure 25. Inactivating a MARK on the Write Port Active

Inactivating a MARK on the Read Port

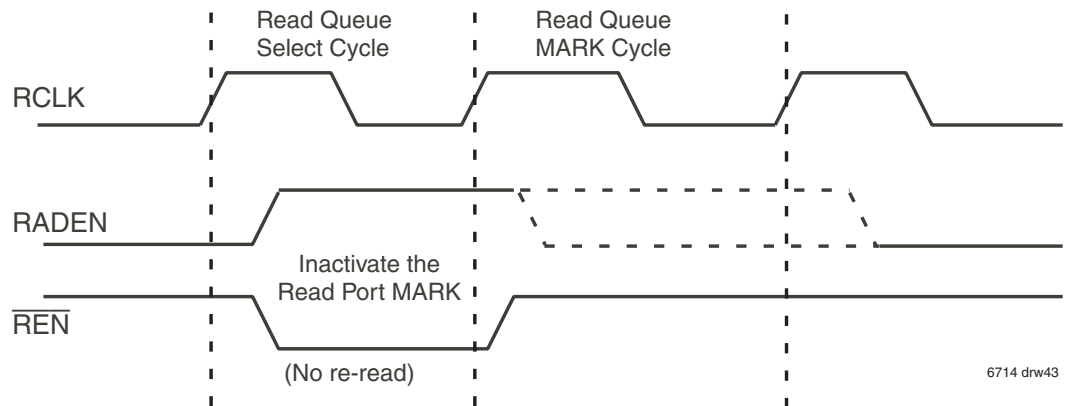

Figure 26. Inactivating a MARK on the Read Port Active

Write Cycle



Action	\overline{WEN} (active LOW)	WADEN (active HIGH)	\overline{WEN} (active LOW)	WADEN (active HIGH)
NO Operation	0	0	0	0
Selects a Queue	0	1	0	1
NO Operation	1	0	1	0
NO Operation	1	1	1	1

6714 drw44

Read Cycle



Action	\overline{REN} (active LOW)	RADEN (active HIGH)	\overline{REN} (active LOW)	RADEN (active HIGH)
NO Operation	0	0	0	0
Selects a Queue	0	1	0	1
NO Operation	1	0	1	0
NO Operation	1	1	1	1

6714 drw45

FLAG DESCRIPTION

PAF_n FLAG BUS OPERATION

The IDT72P51749/72P51759/72P51769 multi-queue flow-control device can be configured for up to 128 queues, each queue having its own almost full status. An active queue has its flag status output to the discrete flags, \overline{FF} and \overline{PAF} , on the write port. Queues that are not selected for a write operation can have their \overline{PAF} status monitored via the $\overline{PAF_n}$ bus. The $\overline{PAF_n}$ flag bus is 8 bits wide, so that 8 queues at a time can have their status output to the bus. If 9 or more queues are setup within a device then there are 2 methods by which the device can share the bus between queues, "Direct" mode and "Polled" mode depending on the state of the FM (Flag Mode) input during a Master Reset. If 8 or less queues are setup within a device then each will have its own dedicated output from the bus. If 8 or less queues are setup in single device mode, it is recommended to configure the $\overline{PAF_n}$ bus to polled mode as it does not require using the write address (WRADD).

FULL FLAG OPERATION

The multi-queue flow-control device provides a single Full Flag output, \overline{FF} . The \overline{FF} flag output provides a full status of the queue currently selected on the write port for write operations. Internally the multi-queue flow-control device monitors and maintains a status of the full condition of all queues within it, however only the queue that is selected for write operations has its full status output to the \overline{FF} flag. This dedicated flag is often referred to as the "active queue full flag".

When queue switches are being made on the write port, the \overline{FF} flag output will switch to the new queue and provide the user with the new queue status, on the 3rd cycle after a new queue selection is made. The user then has a full status for the new queue one cycle ahead of the WCLK rising edge that data can be written into the new queue. That is, a new queue can be selected on the write port via the WRADD bus, WADEN enable and a rising edge of WCLK. On the 4th rising edge of WCLK, the \overline{FF} flag output will show the full status of the newly selected queue. On the forth rising edge of WCLK following the queue selection, data can be written into the newly selected queue provided that data and enable setup & hold times are met.

Note, the \overline{FF} flag will provide status of a newly selected queue three WCLK cycle after queue selection, which is one cycle before data can be written to that queue. This prevents the user from writing data to a queue that is full, (assuming that a queue switch has been made to a queue that is actually full).

The \overline{FF} flag is synchronous to the WCLK and all transitions of the \overline{FF} flag occur based on a rising edge of WCLK. Internally the multi-queue device monitors and keeps a record of the full status for all queues. It is possible that the status of a \overline{FF} flag may be changing internally even though that flag is not the active queue flag (selected on the write port). A queue selected on the read port may experience a change of its internal full flag status based on read operations.

See Figure 44, *Write Queue Select, Write Operation and Full Flag Operation* and Figure 47, *Full Flag Timing in Expansion Configuration* for timing information.

EXPANSION CONFIGURATION - FULL FLAG OPERATION

When multi-queue devices are connected in Expansion configuration the \overline{FF} flags of all devices should be connected together, such that a system controller monitoring and managing the multi-queue devices write port only looks at a single \overline{FF} flag (as opposed to a discrete \overline{FF} flag for each device). This \overline{FF} flag is only pertinent to the queue being selected for write operations at that time. Remember, that when in expansion configuration only one multi-queue device can be written to at any moment in time, thus the \overline{FF} flag provides status of the active queue on the write port.

This connection of flag outputs to create a single flag requires that the \overline{FF} flag output have a High-Impedance capability, such that when a queue selection is

made only a single device drives the \overline{FF} flag bus and all other \overline{FF} flag outputs connected to the \overline{FF} flag bus are placed into High-Impedance. The user does not have to select this High-Impedance state, a given multi-queue flow-control device will automatically place its \overline{FF} flag output into High-Impedance when none of its queues are selected for write operations.

When queues within a single device are selected for write operations, the \overline{FF} flag output of that device will maintain control of the \overline{FF} flag bus. Its \overline{FF} flag will simply update between queue switches to show the respective queue full status.

The multi-queue device places its \overline{FF} flag output into High-Impedance based on the 1-3 bit ID code (1 if two multi-queue are configured with a maximum total of 256 queues, 2 if four devices are used totalling a maximum of 256 queues, and 3 if there are up to eight devices with a maximum total of 256 queues) found in the 1-3 most significant bits of the write queue address bus, WRADD. If the 1-3 most significant bits of WRADD match the 1-3 bit ID code setup on the static inputs, ID0, ID1 and ID2 then the \overline{FF} flag output of the respective device will be in a Low-Impedance state. If they do not match, then the \overline{FF} flag output of the respective device will be in a High-Impedance state. See Figure 47, *Full Flag Timing in Expansion Configuration* for details of flag operation, including when more than one device is connected in expansion.

EMPTY OR OUTPUT READY FLAG OPERATION ($\overline{EF}/\overline{OR}$)

The multi-queue flow-control device provides a single Empty or Output Ready flag output, $\overline{EF}/\overline{OR}$. The \overline{OR} provides an empty status or data Output Ready status for the data word currently available on the output register of the read port. The rising edge of an RCLK cycle that places new data onto the output register of the read port, also updates the \overline{OR} flag to show whether or not that new data word is actually valid. Internally the multi-queue flow-control device monitors and maintains a status of the empty condition of all queues within it, however only the queue that is selected for read operations has its Output Ready (empty) status output to the \overline{OR} flag, giving a valid status for the word being read at that time.

The nature of the first word fall through operation means that when the last data word is read from a selected queue, the \overline{OR} flag will go HIGH on the next enabled read, that is, on the next rising edge of RCLK while \overline{REN} is LOW.

When queue switches are being made on the read port, the \overline{OR} flag will switch to show status of the new queue in line with the data output from the new queue. When a queue selection is made the first data from that queue will appear on the Qout data outputs 4 RCLK cycles later, the \overline{OR} will change state to indicate validity of the data from the newly selected queue on this 3rd RCLK cycle also. The previous cycles will continue to output data from the previous queue and the \overline{OR} flag will indicate the status of those outputs. Again, the \overline{OR} flag always indicates status for the data currently present on the output register.

The \overline{OR} flag is synchronous to the RCLK and all transitions of the \overline{OR} flag occur based on a rising edge of RCLK. Internally the multi-queue device monitors and keeps a record of the Output Ready (empty) status for all queues. It is possible that the status of an \overline{OR} flag may be changing internally even though that respective flag is not the active queue flag (selected on the read port). A queue selected on the write port may experience a change of its internal \overline{OR} flag status based on write operations, that is, data may be written into that queue causing it to become "not empty".

See Figure 48, *Read Queue Select, Read Operation* and Figure 51, *Output Ready Flag Timing* for details of the timing.

EXPANSION - EMPTY FLAG OPERATION

When multi-queue devices are connected in Expansion configuration, the \overline{EF} flags of all devices should be connected together, such that a system controller monitoring and managing the multi-queue devices read port only looks at a single \overline{EF} flag (as opposed to a discrete \overline{EF} flag for each device). This \overline{EF} flag

is only pertinent to the queue being selected for read operations at that time. Remember, that when in expansion configuration only one multi-queue device can be read from at any moment in time, thus the \overline{EF} flag provides status of the active queue on the read port.

This connection of flag outputs to create a single flag requires that the \overline{EF} flag output have a High-Impedance capability, such that when a queue selection is made only a single device drives the \overline{EF} flag bus and all other \overline{EF} flag outputs connected to the \overline{EF} flag bus are placed into High-Impedance. The user does not have to select this High-Impedance state, a given multi-queue flow-control device will automatically place its \overline{EF} flag output into High-Impedance when none of its queues are selected for read operations.

When queues within a single device are selected for read operations, the \overline{EF} flag output of that device will maintain control of the \overline{EF} flag bus. Its \overline{EF} flag will simply update between queue switches to show the respective queue status.

The multi-queue device places its \overline{EF} flag output into High-Impedance based on the 1-3 bit ID code (1 if two multi-queue are configured with a maximum total of 256 queues, 2 if four devices are used totalling a maximum of 256 queues, and 3 if there are up to eight devices with a maximum total of 256 queues) found in the 3 most significant bits of the read queue address bus, RDADD. If the 3 most significant bits of RDADD match the 1-3 bit ID code setup on the static inputs, ID0, ID1 and ID2 then the \overline{EF} flag output of the respective device will be in a Low-Impedance state. If they do not match, then the \overline{EF} flag output of the respective device will be in a High-Impedance state. See Figure 51, *Output Ready Flag Timing* for details of flag operation, including when more than one device is connected in expansion.

ALMOST FULL FLAG

As previously mentioned the multi-queue flow-control device provides a single Programmable Almost Full flag output, PAF. The PAF flag output provides a status of the almost full condition for the active queue currently selected on the write port for write operations. Internally the multi-queue flow-control device monitors and maintains a status of the almost full condition of all queues within it, however only the queue that is selected for write operations has its full status output to the PAF flag. This dedicated flag is often referred to as the "active queue almost full flag". The position of the PAF flag boundary within a queue can be at any point within that queue's depth. This location can be user programmed via the serial port or one of the default values (8 or 128) can be selected if the user has performed default programming.

As mentioned, every queue within a multi-queue device has its own almost full status, when a queue is selected on the write port, this status is output via the PAF flag. The PAF flag value for each queue is programmed during multi-queue device programming (along with the number of queues, queue depths and almost empty values). The PAF offset value, m, for a respective queue can be programmed to be anywhere between '0' and 'D', where 'D' is the total memory depth for that queue. The PAF value of different queues within the same device can be different values.

When queue switches are being made on the write port, the PAF flag output will switch to the new queue and provide the user with the new queue status, on the third cycle after a new queue selection is made, on the same WCLK cycle that data can actually be written to the new queue. That is, a new queue can be selected on the write port via the WRADD bus, WADEN enable and a rising edge of WCLK. On the third rising edge of WCLK following a queue selection, the PAF flag output will show the full status of the newly selected queue. The PAF flag output is double register buffered, so when a write operation occurs at the almost full boundary causing the selected queue status to go almost full the PAF will go LOW 2 WCLK cycles after the write. The same is true when a read occurs, there will be a 2 WCLK cycle delay after the read operation.

So the \overline{PAF} flag delay from a write operation to \overline{PAF} flag LOW is $2WCLK + tWAF$. The delay from a read operation to \overline{PAF} flag HIGH is $tSKEW2 + WCLK + tWAF$.

Note, if tSKEW is violated there will be one added WCLK cycle delay.

The PAF flag is synchronous to the WCLK and all transitions of the PAF flag occur based on a rising edge of WCLK. Internally the multi-queue device monitors and keeps a record of the almost full status for all queues. It is possible that the status of a PAF flag maybe changing internally even though that flag is not the active queue flag (selected on the write port). A queue selected on the read port may experience a change of its internal almost full flag status based on read operations. The multi-queue flow-control device also provides a duplicate of the PAF flag on the PAF[7:0] flag bus, this will be discussed in detail in a later section of the data sheet.

See Figures 23 and 24 for Almost Full flag timing and queue switching.

ALMOST EMPTY FLAG

As previously mentioned the multi-queue flow-control device provides a single Programmable Almost Empty flag output, PAE. The PAE flag output provides a status of the almost empty condition for the active queue currently selected on the read port for read operations. Internally the multi-queue flow-control device monitors and maintains a status of the almost empty condition of all queues within it, however only the queue that is selected for read operations has its empty status output to the PAE flag. This dedicated flag is often referred to as the "active queue almost empty flag". The position of the PAE flag boundary within a queue can be at any point within that queue's depth. This location can be user programmed via the serial port or one of the default values (8 or 128) can be selected if the user has performed default programming.

As mentioned, every queue within a multi-queue device has its own almost empty status, when a queue is selected on the read port, this status is output via the PAE flag. The PAE flag value for each queue is programmed during multi-queue device programming (along with the number of queues, queue depths and almost full values). The PAE offset value, n, for a respective queue can be programmed to be anywhere between '0' and 'D', where 'D' is the total memory depth for that queue. The PAE value of different queues within the same device can be different values.

When queue switches are being made on the read port, the PAE flag output will switch to the new queue and provide the user with the new queue status, on the third cycle after a new queue selection is made, on the same RCLK cycle that data actually falls through to the output register from the new queue. That is, a new queue can be selected on the read port via the RDADD bus, RADEN enable and a rising edge of RCLK. On the third rising edge of RCLK following a queue selection, the data word from the new queue will be available at the output register and the PAE flag output will show the empty status of the newly selected queue. The PAE flag output is double register buffered, so when a read operation occurs at the almost empty boundary causing the selected queue status to go almost empty the PAE will go LOW 2 RCLK cycles after the read. The same is true when a write occurs, there will be a 3 RCLK cycle delay after the write operation.

So the PAE flag delay from a read operation to PAE flag LOW is $2RCLK + tRAE$. The delay from a write operation to PAE flag HIGH is $tSKEW2 + RCLK + tRAE$.

Note, if tSKEW is violated there will be one added RCLK cycle delay.

The PAE flag is synchronous to the RCLK and all transitions of the PAE flag occur based on a rising edge of RCLK. Internally the multi-queue device monitors and keeps a record of the almost empty status for all queues. It is possible that the status of a PAE flag maybe changing internally even though that flag is not the active queue flag (selected on the read port). A queue selected on the

write port may experience a change of its internal almost empty flag status based on write operations. The multi-queue flow-control device also provides a duplicate of the PAE flag on the PAE[7:0] flag bus, this will be discussed in detail in a later section of the data sheet.

See Figures 25 and 26 for Almost Empty flag timing and queue switching.

PAFn - DIRECT BUS

If FM is LOW at master reset then the PAFn bus operates in Direct (addressed) mode. In direct mode the user can address the status word of queues they require and it will be placed on to the PAFn bus. For example, consider the operation of the PAFn bus when 26 queues have been setup. To output status of the first status word, Queue[0:7] the WRADD bus is used in conjunction with the FSTR (PAF flag strobe) input and WCLK. The address present on the 4 least significant bits of the WRADD bus with FSTR HIGH will be selected as the status word address on a rising edge of WCLK. To address status word 0, Queue[0:7] the WRADD bus should be loaded with "0010000", the PAFn bus will change status to show the new status word selected 1 WCLK cycle after status word selection. PAFn[0:7] gets status of queues, Queue[0:7] respectively.

To address status word 1, Queue[8:15], the WRADD address is "00100001". PAFn[0:7] gets status of queues, Queue[8:15] respectively. To address the 2nd status word, Queue[16:23], the WRADD address is "00100010". PAF[0:7] gets status of queues, Queue[16:23] respectively. To address the 3rd status word, Queue[24:31], the WRADD address is "00100011". PAF[0:1] gets status of queues, Queue[24:25] respectively. Remember, only 26 queues were setup, so when status word 4 is selected the unused outputs PAF[2:7] will be don't care states.

Note, that if a read or write operation is occurring to a specific queue, say queue 'x' on the same cycle as a status word switch which will include the queue 'x', then there may be an extra WCLK cycle delay before that queues status is correctly shown on the respective output of the PAFn bus. However, the active PAF flag will show correct status at all times.

Status words can be selected on consecutive clock cycles, that is the status word on the PAFn bus can change every WCLK cycle. Also, data present on the input bus, Din, can be written into a Queue on the same WCLK rising edge that a status word is being selected, the only restriction being that a write queue selection and PAFn status word selection cannot be made on the same cycle.

If 8 or less queues are setup then queues, Queue[0:7] have their PAF status output on PAF[0:7] constantly.

When the multi-queue devices are connected in expansion of more than one device the PAFn busses of all devices are connected together, when switching between status words of different devices the user must utilize the 1-3 most significant bits of the WRADD address bus (as well as the 2 LSB's). These 1-3 MSb's correspond to the device ID inputs, which are the static inputs, ID0, ID1 & ID2.

Please refer to Figure 63 *PAFn - Direct Mode Status Word Selection* for timing information. Also refer to Table 4, *Write Address Bus, WRADD*.

PAFn - POLLED BUS

If FM is HIGH at master reset then the PAFn bus operates in Polled (looped) mode. In polled mode the PAFn bus only cycles through the number of status words required to display the status of the number of queues that have been setup in the part. Every rising edge of the WCLK causes the next status word to be loaded on the PAFn bus. The device configured as the master (MAST input tied HIGH), will take control of the PAFn after MRS goes LOW. For the whole WCLK cycle that the first status word is on PAFn the FSYNC (PAFn bus sync) output will be HIGH, for all other status words, this FSYNC output will be LOW. This FSYNC output provides the user with a mark with which they can

synchronize to the PAFn bus, FSYNC is always HIGH for the WCLK cycle that the first status word of a device is present on the PAFn bus.

When devices are connected in expansion configuration, only one device will be set as the Master (ID = '000'), MAST input tied HIGH, all other devices will have MAST tied LOW. The master device is the first device to take control of the PAFn bus and will place its first status word on the bus on the rising edge of WCLK. For the next n WCLK cycles (n = number of queues divided by 8 with n being increased by one for any remainder) the master device will maintain control of the PAFn bus and cycle its status words through it, all other devices hold their PAFn outputs in High-Impedance. When the master device has cycled all of its status words it passes a token to the next device in the chain and that device assumes control of the PAFn bus and then cycles its status words and so on, the PAFn bus control token being passed on from device to device. This token passing is done via the FXO outputs and FXI inputs of the devices ("PAF Expansion Out" and "PAF Expansion In"). The FXO output of the master device connects to the FXI of the second device in the chain and the FXO of the second connects to the FXI of the third and so on. The final device in a chain has its FXO connected to the FXI of the first device, so that once the PAFn bus has cycled through all status words of all devices, control of the PAFn will pass to the master device again and so on. The FSYNC of each respective device will operate independently and simply indicate when that respective device has taken control of the bus and is placing its first status word on to the PAFn bus.

When operating in single device mode the FXI input must be connected to the FXO output of the same device. In single device mode a token is still required to be passed into the device for accessing the PAFn bus.

Please refer to Figure 66, *PAFn Bus - Polled Mode* for timing information.

PAEn/PRn FLAG BUS OPERATION

The IDT72P51749/72P51759/72P51769 multi-queue flow-control device can be configured for up to 128 queues, each queue having its own almost empty/ packet ready status. An active queue has its flag status output to the discrete flags, OR, PAE and PR, on the read port. Queues that are not selected for a read operation can have their PAE/PR status monitored via the PAEn/PRn bus. The PAEn/PRn flag bus is 8 bits wide, so that 8 queues at a time can have their status output to the bus. If 9 or more queues are setup within a device then there are 2 methods by which the device can share the bus between queues, "Direct" mode and "Polled" mode depending on the state of the FM (Flag Mode) input during a Master Reset. If 8 or less queues are setup within a device then each will have its own dedicated output from the bus. If 8 or less queues are setup in single device mode, it is recommended to configure the PAFn bus to polled mode as it does not require using the write address (WRADD).

PAEn/PRn - DIRECT BUS

If FM is LOW at master reset then the PAEn/PRn bus operates in Direct (addressed) mode. In direct mode the user can address the status word of queues they require to be placed on to the PAEn/PRn bus. For example, consider the operation of the PAEn/PRn bus when 26 queues have been setup. To output status of the first status word, Queue[0:7] the RDADD bus is used in conjunction with the ESTR (PAE/PR flag strobe) input and RCLK. The address present on the 2 least significant bits of the RDADD bus with ESTR HIGH will be selected as the status word address on a rising edge of RCLK. So to address status word 1, Queue[0:7] the RDADD bus should be loaded with "xxxx0000", the PAEn/PRn bus will change status to show the new status word selected 1 RCLK cycle after status word selection. PAEn[0:7] gets status of queues, Queue[0:7] respectively.

To address the second status word, Queue[8:15], the RDADD address is "xxxx0001". PAEn[0:7] gets status of queues, Queue[8:15] respectively. To

TABLE 9 — FLAG OPERATION BOUNDARIES & TIMING

Output Ready, \overline{EF} Flag Boundary	
I/O Set-Up	\overline{EF} Boundary Condition
In36 to out36 (Almost Empty Mode) (Both ports selected for same queue when the 1 st Word is written in)	\overline{EF} Goes LOW after Last Read
In36 to out36 (Packet Mode) (Both ports selected for same queue when the 1 st Word is written in)	\overline{EF} Goes LOW after Last Read
In36 to out18 (Both ports selected for same queue when the 1 st Word is written in)	\overline{EF} Goes LOW after Last Read
In36 to out9 (Both ports selected for same queue when the 1 st Word is written in)	\overline{EF} Goes LOW after Last Read
In18 to out36 (Both ports selected for same queue when the 1 st Word is written in)	\overline{EF} Goes LOW after Last Read
In9 to out36 (Both ports selected for same queue when the 1 st Word is written in)	\overline{EF} Goes LOW after Last Read

Full Flag, \overline{FF} Boundary	
I/O Set-Up	\overline{FF} Boundary Condition
In36 to out36 (Both ports selected for same queue when the 1 st Word is written in)	\overline{FF} Goes LOW after D+1 Writes (see note below for timing)
In36 to out36 (Write port only selected for queue when the 1 st Word is written in)	\overline{FF} Goes LOW after D Writes (see note below for timing)
In36 to out18 (Both ports selected for same queue when the 1 st Word is written in)	\overline{FF} Goes LOW after D Writes (see note below for timing)
In36 to out18 (Write port only selected for queue when the 1 st Word is written in)	\overline{FF} Goes LOW after D Writes (see note below for timing)
In36 to out9 (Both ports selected for same queue when the 1 st Word is written in)	\overline{FF} Goes LOW after D Writes (see note below for timing)
In36 to out9 (Write port only selected for queue when the 1 st Word is written in)	\overline{FF} Goes LOW after D Writes (see note below for timing)
In18 to out36 (Both ports selected for same queue when the 1 st Word is written in)	\overline{FF} Goes LOW after ((D+1) x 2) Writes (see note below for timing)
In18 to out36 (Write port only selected for queue when the 1 st Word is written in)	\overline{FF} Goes LOW after (D x 2) Writes (see note below for timing)
In9 to out36 (Both ports selected for same queue when the 1 st Word is written in)	\overline{FF} Goes LOW after ((D+1) x 4) Writes (see note below for timing)
In9 to out36 (Write port only selected for queue when the 1 st Word is written in)	\overline{FF} Goes LOW after (D x 4) Writes (see note below for timing)

Programmable Almost Full Flag, \overline{PAF} & \overline{PAFn} Bus Boundary	
I/O Set-Up	\overline{PAF} & \overline{PAFn} Boundary
in36 to out36 (Both ports selected for same queue when the 1 st Word is written in until the boundary is reached)	$\overline{PAF}/\overline{PAFn}$ Goes LOW after D+1-m Writes (see note below for timing)
in36 to out36 (Write port only selected for same queue when the 1 st Word is written in until the boundary is reached)	$\overline{PAF}/\overline{PAFn}$ Goes LOW after D-m Writes (see note below for timing)
in36 to out18	$\overline{PAF}/\overline{PAFn}$ Goes LOW after D-m Writes (see below for timing)
in36 to out9	$\overline{PAF}/\overline{PAFn}$ Goes LOW after D-m Writes (see below for timing)
in18 to out36	$\overline{PAF}/\overline{PAFn}$ Goes LOW after ((D+1-m) x 2) Writes (see note below for timing)
in9 to out36	$\overline{PAF}/\overline{PAFn}$ Goes LOW after ((D+1-m) x 4) Writes (see note below for timing)

NOTE:

D = Queue Depth
 m = Almost Full Offset value.
 Default values: if DF is LOW at Master Reset then m = 8
 if DF is HIGH at Master Reset then m = 128

\overline{PAF} Timing

Assertion: Write Operation to \overline{PAF} LOW: 2 WCLK + tWAF
 De-assertion: Read to \overline{PAF} HIGH: tSKEW2 + WCLK + tWAF
 If tSKEW2 is violated there may be 1 added clock: tSKEW2 + 2 WCLK + tWAF

\overline{PAFn} Timing

Assertion: Write Operation to \overline{PAFn} LOW: 2 WCLK* + tPAF
 De-assertion: Read to \overline{PAFn} HIGH: tSKEW3 + WCLK* + tPAF
 If tSKEW3 is violated there may be 1 added clock: tSKEW3 + 2 WCLK* + tPAF

* If a queue switch is occurring on the write port at the point of flag assertion or de-assertion there may be one additional WCLK clock cycle delay.

NOTE:

D = Queue Depth
FF Timing
 Assertion:
 Write Operation to \overline{FF} LOW: tWFF
 De-assertion:
 Read to \overline{FF} HIGH: tSKEW1 + tWFF
 If tSKEW1 is violated there may be 1 added clock: tSKEW1+WCLK +tWFF

TABLE 9 — FLAG OPERATION BOUNDARIES & TIMING (CONTINUED)

Programmable Almost Empty Flag, $\overline{\text{PAE}}$ Boundary	
I/O Set-Up	$\overline{\text{PAE}}$ Assertion
in36 to out36 (Both ports selected for same queue when the 1 st Word is written in until the boundary is reached)	$\overline{\text{PAE}}$ Goes HIGH after n+2 Writes (see note below for timing)
in36 to out18 (Both ports selected for same queue when the 1 st Word is written in until the boundary is reached)	$\overline{\text{PAE}}$ Goes HIGH after n+1 Writes (see note below for timing)
in36 to out9 (Both ports selected for same queue when the 1 st Word is written in until the boundary is reached)	$\overline{\text{PAE}}$ Goes HIGH after n+1 Writes (see note below for timing)
in18 to out36 (Both ports selected for same queue when the 1 st Word is written in until the boundary is reached)	$\overline{\text{PAE}}$ Goes HIGH after (n+2) x 2) Writes (see note below for timing)
in9 to out36 (Both ports selected for same queue when the 1 st Word is written in until the boundary is reached)	$\overline{\text{PAE}}$ Goes HIGH after (n+2) x 4) Writes (see note below for timing)

NOTE:

n = Almost Empty Offset value.

Default values: if DF is LOW at Master Reset then n = 8
if DF is HIGH at Master Reset then n = 128

$\overline{\text{PAE}}$ Timing

Assertion: Read Operation to $\overline{\text{PAE}}$ LOW: 2 RCLK + tRAE

De-assertion: Write to $\overline{\text{PAE}}$ HIGH: tSKEW2 + RCLK + tRAE

If tSKEW2 is violated there may be 1 added clock: tSKEW2 + 2 RCLK + tRAE

Programmable Almost Empty Flag Bus, $\overline{\text{PAEn}}$ Boundary	
I/O Set-Up	$\overline{\text{PAEn}}$ Boundary Condition
in36 to out36 (Both ports selected for same queue when the 1 st Word is written in until the boundary is reached)	$\overline{\text{PAEn}}$ Goes HIGH after n+2 Writes (see note below for timing)
in36 to out36 (Write port only selected for same queue when the 1 st Word is written in until the boundary is reached)	$\overline{\text{PAEn}}$ Goes HIGH after n+1 Writes (see note below for timing)
in36 to out18	$\overline{\text{PAEn}}$ Goes HIGH after n+1 Writes (see below for timing)
in36 to out9	$\overline{\text{PAEn}}$ Goes HIGH after n+1 Writes (see below for timing)
in18 to out36 (Both ports selected for same queue when the 1 st Word is written in until the boundary is reached)	$\overline{\text{PAEn}}$ Goes HIGH after (n+2) x 2) Writes (see note below for timing)
in18 to out36 (Write port only selected for same queue when the 1 st Word is written in until the boundary is reached)	$\overline{\text{PAEn}}$ Goes HIGH after (n+1) x 2) Writes (see note below for timing)
in9 to out36 (Both ports selected for same queue when the 1 st Word is written in until the boundary is reached)	$\overline{\text{PAEn}}$ Goes HIGH after (n+2) x 4) Writes (see note below for timing)
in9 to out36 (Write port only selected for same queue when the 1 st Word is written in until the boundary is reached)	$\overline{\text{PAEn}}$ Goes HIGH after (n+1) x 4) Writes (see note below for timing)

NOTE:

n = Almost Empty Offset value.

Default values: if DF is LOW at Master Reset then n = 8
if DF is HIGH at Master Reset then n = 128

$\overline{\text{PAEn}}$ Timing

Assertion: Read Operation to $\overline{\text{PAEn}}$ LOW: 2 RCLK* + tPAE

De-assertion: Write to $\overline{\text{PAEn}}$ HIGH: tSKEW3 + RCLK* + tPAE

If tSKEW3 is violated there may be 1 added clock: tSKEW3 + 2 RCLK* + tPAE

* If a queue switch is occurring on the read port at the point of flag assertion or de-assertion there may be one additional RCLK clock cycle delay.

PACKET READY FLAG, $\overline{\text{PR}}$ BOUNDARY

Assertion:

Both the rising and falling edges of $\overline{\text{PR}}$ are synchronous to RCLK.

$\overline{\text{PR}}$ Falling Edge occurs upon writing the first TEOP marker, on input D35, (assuming a TSOP marker, on input D34 has previously been written). i.e. a complete packet is available within a queue.

Timing:

From WCLK rising edge writing the TEOP word $\overline{\text{PR}}$ goes LOW after: tSKEW4 + 2 RCLK + tPR

If tSKEW4 is violated:

$\overline{\text{PR}}$ goes LOW after tSKEW4 + 3 RCLK + tPR

De-assertion:

$\overline{\text{PR}}$ Rising Edge occurs upon reading the last RSOP marker, from output Q34. i.e. there are no more complete packets available within the queue.

Timing:

From RCLK rising edge Reading the RSOP word the $\overline{\text{PR}}$ goes HIGH after: 3 RCLK + tPR

(Please refer to Figure 57, *Data Output (Receive) Packet Mode of Operation* for timing diagram).

PACKET READY FLAG BUS, $\overline{\text{PRn}}$ BOUNDARY

Assertion:

Both the rising and falling edges of $\overline{\text{PRn}}$ are synchronous to RCLK.

$\overline{\text{PRn}}$ Falling Edge occurs upon writing the first TEOP marker, on input D35, (assuming a TSOP marker, on input D34 has previously been written). i.e. a complete packet is available within a queue.

Timing:

From WCLK rising edge writing the TEOP word $\overline{\text{PRn}}$ goes LOW after: tSKEW4 + 2 RCLK* + tPAE

If tSKEW4 is violated $\overline{\text{PRn}}$ goes LOW after tSKEW4 + 3 RCLK* + tPAE

*If a queue switch is occurring on the read port at the point of flag assertion there may be one additional RCLK clock cycle delay.

De-assertion:

$\overline{\text{PRn}}$ Rising Edge occurs upon reading the last RSOP marker, from output Q34. i.e. there are no more complete packets available within the queue.

Timing:

From RCLK rising edge Reading the RSOP word the $\overline{\text{PRn}}$ goes HIGH after: 3 RCLK* + tPAE

*If a queue switch is occurring on the read port at the point of flag assertion or de-assertion there may be one additional RCLK clock cycle delay.

address the third status word, Queue[16:23], the RDADD address is "xxxx0010". PAE[0:7] gets status of queues, Queue[16:23] respectively. To address the fourth status word, Queue[24:31], the RDADD address is "xxxx0011". PAE[0:1] gets status of queues, Queue[24:25] respectively. Remember, only 26 queues were setup, so when status word 4 is selected the unused outputs PAE[2:7] will be don't care states.

Note, that if a read or write operation is occurring to a specific queue, say queue 'x' on the same cycle as a status word switch which will include the queue 'x', then there may be an extra RCLK cycle delay before that queues status is correctly shown on the respective output of the PAE/PRn bus.

Status words can be selected on consecutive clock cycles, that is the status word on the PAE/PRn bus can change every RCLK cycle. Also, data can be read out of a Queue on the same RCLK rising edge that a status word is being selected, the only restriction being that a read queue selection and PAE/PRn status word selection cannot be made on the same RCLK cycle.

If 8 or less queues are setup then queues, Queue[0:7] have their PAE/PR status output on PAE[0:7] constantly.

When the multi-queue devices are connected in expansion of more than one device the PAE/PRn busses of all devices are connected together, when switching between status words of different devices the user must utilize the 3 most significant bits of the RDADD address bus (as well as the 2 LSB's). These 3 MSB's correspond to the device ID inputs, which are the static inputs, ID0, ID1 & ID2.

Please refer to Figure 62, PAE/PRn - Direct Mode Status Word Selection for timing information. Also refer to Table 5, Read Address Bus, RDADD.

PAE – POLLED BUS

If FM is HIGH at master reset then the PAE/PRn bus operates in Polled (looped) mode. In polled mode the PAE/PRn bus automatically cycles through the 4 status words within the device regardless of how many queues have been setup in the part. Every rising edge of the RCLK causes the next status word to be loaded on the PAE/PRn bus. The device configured as the master (MAST input tied HIGH), will take control of the PAE/PRn after MRS goes LOW. For the whole RCLK cycle that the first status word is on PAE/PRn the ESYNC (PAE/PRn bus sync) output will be HIGH, for all other status words, this ESYNC output will be LOW. This ESYNC output provides the user with a mark with which they can synchronize to the PAE/PRn bus, ESYNC is always HIGH for the RCLK cycle that the first status word of a device is present on the PAE/PRn bus.

When devices are connected in expansion configuration, only one device will be set as the Master (ID='000'), MAST input tied HIGH, all other devices will have MAST tied LOW. The master device is the first device to take control of the PAE/PRn bus and will place its first status word on the bus on the rising edge of RCLK after the MRS input goes LOW. For the next n RCLK cycles (n=number of queues divided by 8 with n incrementing by one should there be a remainder) the master device will maintain control of the PAE/PRn bus and cycle its status words through it, all other devices hold their PAE/PRn outputs in High-Impedance. When the master device has cycled all of its status words it passes a token to the next device in the chain and that device assumes control of the PAE/PRn bus and then cycles its status words and so on, the PAE/PRn bus control token being passed on from device to device. This token passing is done via the EXO outputs and EXI inputs of the devices ("PAE Expansion Out" and "PAE Expansion In"). The EXO output of the master device connects to the EXI of the second device in the chain and the EXO of the second connects to the EXI of the third and so on. The final device in a chain has its EXO connected to the EXI of the first device, so that once the PAE/PRn bus has cycled through all status words of all devices, control of the PAE/PRn will pass to the master device again and so on. The ESYNC of each respective device will operate

independently and simply indicate when that respective device has taken control of the bus and is placing its first status word on to the PAE/PRn bus.

When operating in single device mode the EXI input must be connected to the EXO output of the same device. In single device mode a token is still required to be passed into the device for accessing the PAE bus.

PACKET READY FLAG

The 36-bit multi-queue flow-control device provides the user with a Packet Ready feature. During a Master Reset Packet Mode is selected by PKT = HIGH. The PR discrete flag, provides a packet ready status of the active queue selected on the read port. A packet ready status is individually maintained on all queues; however only the queue selected on the read port has its packet ready status indicated on the PR output flag. A packet is available on the output for reading when both PR and OR are asserted LOW. If less than a full packet is available, the PR flag will be HIGH (packet not ready). In packet mode, no words can be read from a queue until a complete packet has been written into that queue, regardless of REN.

When packet mode is selected the Programmable Almost Empty bus, PAE, becomes the Packet Ready bus, PRn. When configured in Direct Bus (FM = LOW during a master reset), the PRn bus provides packet ready status in 8 queue increments. The PRn bus supports either Polled or Direct modes of operation. The PRn mode of operation is configured through the Flag Mode (FM) bit during a Master Reset.

When the multi-queue is configured for packet mode operation, the two most significant bits of the 36-bit data bus are used as "packet markers". On the write port these are bits D34 (Transmit Start of Packet), D35 (Transmit End of Packet) and on the read port Q34, Q35. All four bits are monitored by the packet control logic as data is written into and read out from the queues. The packet ready status for individual queues is then determined by the packet ready logic.

On the write port D34 is used to "mark" the first word being written into the selected queue as the "Transmit Start of Packet", TSOP. To further clarify, when the user requires a word being written to be marked as the start of a packet, the TSOP input (D34) must be HIGH for the same WCLK rising edge as the word that is written. The TSOP marker is stored in the queue along with the data it was written in until the word is read out of the queue via the read port.

On the write port D35 is used to "mark" the last word of the packet currently being written into the selected queue as the "Transmit End of Packet" TEOP. When the user requires a word being written to be marked as the end of a packet, the TEOP input must be HIGH for the same WCLK rising edge as the word that is written in. The TEOP marker is stored in the queue along with the data it was written in until the word is read out of the queue via the read port.

The packet ready logic monitors all start and end of packet markers both as they enter respective queues via the write port and as they exit queues via the read port. The multi-queue internal logic increments and decrements a packet counter, which is provided for each queue. The functionality of the packet ready logic provides status as to whether at least one full packet of data is available within the selected queue. A partial packet in a queue is regarded as a packet not ready and PR (active LOW) will be HIGH. In Packet mode, no words can be read from a queue until at least one complete packet has been written into the queue, regardless of REN. For example, if a TSOP has been written and some number of words later a TEOP is written a full packet of data is deemed to be available, and the PR flag and OR will go active LOW. Consequently if reads begin from a queue that has only one complete packet and the RSOP is detected on the output port as data is being read out, PR will go inactive HIGH. OR will remain LOW indicating there is still valid data being read out of that queue until the REOP is read. The user may proceed with the reading operation until the current packet has been read out and no further complete packets are available. If during that time another complete packet has been written into the queue and

the \overline{PR} flag will again gone active, then reads from the new packet may follow after the current packet has been completely read out.

The packet counters therefore look for start of packet markers followed by end of packet markers and regard data in between the TSOP and TEOP as a full packet of data. The packet monitoring has no limitation as to how many packets are written into a queue, the only constraint is the depth of the queue. Note, there is a minimum allowable packet size of four words, inclusive of the TSOP marker and TEOP marker.

The packet logic does expect a TSOP marker to be followed by a TEOP marker.

If a second TSOP marker is written after a first, it is ignored and the logic regards data between the first TSOP and the first subsequent TEOP as the full packet. The same is true for TEOP; a second consecutive TEOP mark is ignored. On the read side the user should regard a packet as being between the first RSOP and the first subsequent REOP and disregard consecutive RSOP markers and/or REOP markers. This is why a TEOP may be written twice, using the second TEOP as the "filler" word.

As an example, the user may also wish to implement the use of an "Almost End of Packet" (AEOP) marker. For example, the AEOP can be assigned to data input bit D33. The purpose of this AEOP marker is to provide an indicator that the end of packet is a fixed (known) number of reads away from the end of packet. This is a useful feature when due to latencies within the system, monitoring the REOP marker alone does not prevent "over reading" of the data from the queue selected. For example, an AEOP marker set 4 writes before the TEOP marker provides the device connected to the read port with an "almost end of packet" indication 4 cycles before the end of packet.

The AEOP can be set any number of words before the end of packet determined by user requirements or latencies involved in the system.

See Figure 55, *Reading in Packet Mode during a Queue Change*, Figure 57, *Data Output (Receive) Packet Mode of Operation*.

PACKET MODE – MODULO OPERATION

The internal packet ready control logic performs no operation on these modulo bits, they are only informational bits that are passed through with the respective data byte(s).

When utilizing the multi-queue flow-control device in packet mode, the user may also want to consider the implementation of "Modulo" operation or "valid byte marking". Modulo operation may be useful when the packets being transferred through a queue are in a specific byte arrangement even though the data bus width is 36 bits. In Modulo operation the user can concatenate bytes to form a specific data string through the multi-queue device. A possible scenario is where a limited number of bytes are extracted from the packet for either analysis or filtered for security protection. This will only occur when the first 36 bit word of a packet is written in and the last 36 bit word of packet is written in. The modulo operation is a means by which the user can mark and identify specific data within the Queue.

On the write port data input bits, D32 (transmit modulo bit 2, TMOD2) and D33 (transmit modulo bit 1, TMOD1) can be used as data markers. An example of this could be to use D32 and D33 to code which bytes of a word are part of the packet that is also being marked as the "Start of Marker" or "End of Marker". Conversely on the read port when reading out these marked words, data outputs Q32 (receive modulo bit 2, RMOD2) and Q33 (receive modulo bit 1, RMOD1) will pass on the byte validity information for that word. Refer to Table 10 for one example of how the modulo bits may be setup and used. See Figure 57, *Data Output (Receive) Packet Mode of Operation*.

TABLE 10 — PACKET MODE VALID BYTE FOR x36 BIT WORD CONFIGURATION

D35/Q35	D34/Q34	D33/Q33	D32/Q32	D31/Q31	D23/Q23	D15/Q15	D7/Q7	D0/Q0
EOP	SOP	MOD 1	MOD 2	BYTE D	BYTE C	BYTE B	BYTE A	

TMOD1 (D33) RMOD1 (Q33)	TMOD2 (D32) RMOD2 (Q32)	VALID BYTES
0	0	A, B, C, D
0	1	A
1	0	A, B
1	1	A, B, C

6714 drw19

PACKET MODE DEMARCATION BITS

The IDT72P51749/72P51759/72P51769 can be configured for packet mode operation. In packet mode the IDT72P51749/72P51759/72P51769 provides the functionality to demarcate packets within a queue. The demarcation functionality is only available in packet mode and is used to generate the Packet Ready (PR) flag.

The demarcation of packets/information is accomplished with the demarcation bits [35:32]. The demarcation bit assignments are; bit 35 End of Packet (EOP), bit 34 Start of Packet (SOP), bit 33 Almost End of Packet (AEOP) and bit 32 Almost Start of Packet (ASOP).

During packet mode bus matching, which is the ability to set the write interface and read interface to independent word lengths (i.e. 9 bit word, 18 bit word, 36 bit word), the demarcation bits are located within their respective word length. For example within a 36 bit to 36 bit word bus matching configuration bit 35 is designated as the End of Packet (EOP) and bit 34 is Start of Packet (SOP). In an 18 bit to 18 bit word bus matching configuration bit 17 is designated End of Packet (EOP) and bit 16 is Start of Packet. The minimum packet word length required by the IDT72P51749/72P51759/72P51769 is four (4) of the largest words specified within a bus matching configuration. Refer to Figure 27-35 for designated locations of the demarcation bits within a specific word configuration.

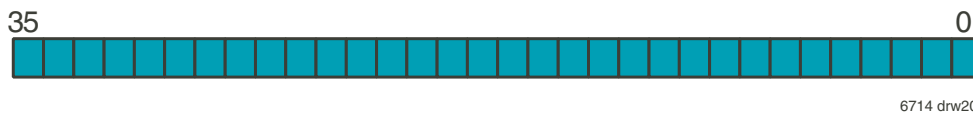

- NOTES:**
1. A Start of Packet (SOP) and End of Packet (EOP) may not occur within a same word.
 2. The x36 bit words locate SOP and EOP as follows;
 - a. bit 35 is EOP
 - b. bit 34 is SOP.

Figure 27. 36bit to 36bit word configuration

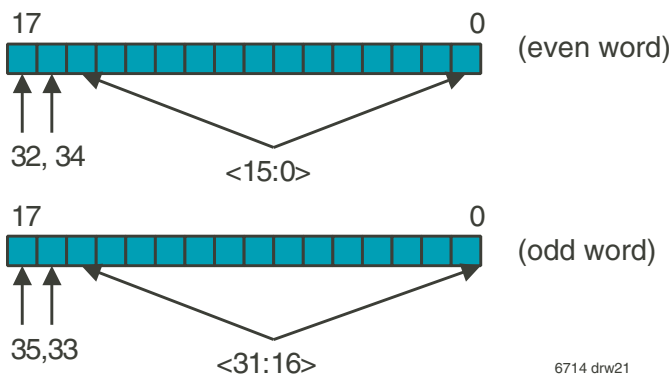

- NOTES:**
1. In a 36 bit word to 18 bit word configuration the 36 bit word is converted to two (2) 18 bit words.
 2. An SOP and EOP may not occur within a same word.
 3. The x18 bit even words (0,2,4, etc.) contain demarcation bits 32 (ASOP) and 34 (SOP).
 4. The x18 bit odd words (1,3,5, etc.) contain demarcation bits 33 (AEOP) and 35 (EOP).

Figure 28. 36bit to 18bit word configuration

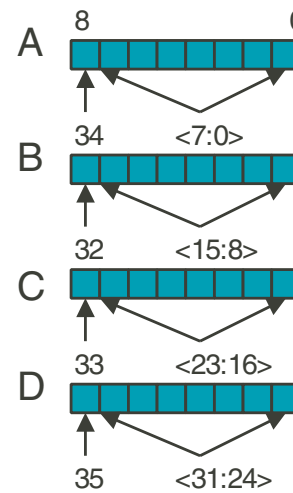

- NOTES:**
1. In a 36 bit word to 9 bit word configuration the 36 bit word is converted into four (4) 9 bit words.
 2. An SOP and EOP may not occur within a same word.
 3. The x9 bit words contain the demarcation bits as follows;
 - a. Bit 8 in Word "A" is the Start of Packet (SOP)
 - b. Bit 8 in Word "B" is the Almost Start of Packet (ASOP).
 - c. Bit 8 in Word "C" is the Almost End of Packet (AEOP).
 - d. Bit 8 in Word "D" is the End of Packet (EOP).

Figure 29. 36bit to 9bit word configuration

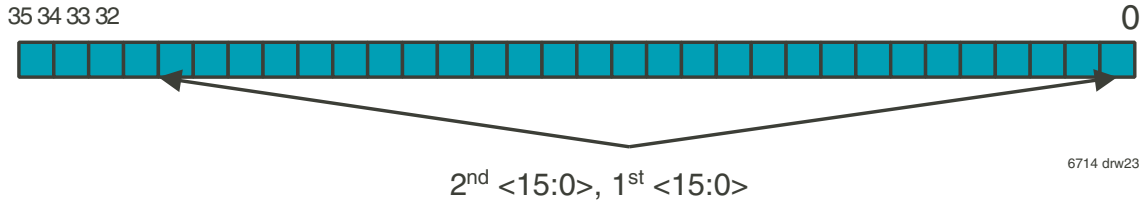

6714 drw23

NOTES:

1. In a 18bit word to 36 bit word configuration two (2) eighteen bit words are concatenated to form one x36 bit word.
2. The x36 bit words contain demarcation bits as follows;
 - a. Bit 35 is End of Packet (EOP)
 - b. Bit 34 is Start of Packet (SOP).
 - c. Bit 33 Almost End of Packet (AEOP).
 - d. Bit 32 Almost Start of Packet (ASOP).

Figure 30. 18bit to 36bit word configuration



6714 drw24

NOTES:

1. An SOP and EOP may not occur within a same word.
2. The x18 bit words contain the demarcation bits as follows;
 - a. Bit 17 is the End of Packet (EOP).
 - b. Bit 16 is the Start of Packet (SOP).
3. In this configuration there is no ASOP or AEOP demarcation bits.

Figure 31. 18bit to 18bit word configuration

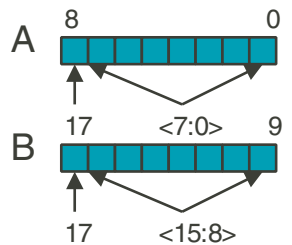

6714 drw24a

NOTES:

1. In a 18 bit word to 9 bit word configuration a single eighteen bit word is converted into two (2) nine bit words.
2. The x9 bit words contain demarcation bits as follows;
 - a. Bit 17 is End of Packet (EOP)
 - b. Bit 16 is Start of Packet (SOP).
3. An SOP and EOP may not occur within the same word.
4. In this configuration there is no ASOP or AEOP demarcation bits.

Figure 32. 18bit to 9bit word configuration

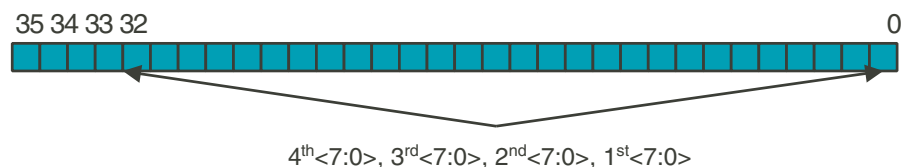

6714 drw25

NOTES:

1. In a 9 bit word to 36 bit word configuration four (4), nine bit words are concatenated to form one x36 bit word.
2. The x36 bit words contain demarcation bits as follows;
 - a. Bit 35 is End of Packet (EOP)
 - b. Bit 34 is Start of Packet (SOP).
 - c. Bit 33 Almost End of Packet (AEOP).
 - d. Bit 32 Almost Start of Packet (ASOP).

Figure 33. 9bit to 36bit word configuration



6714 drw26

NOTES:

1. In a 9 bit word to 18 bit word configuration two (2), nine bit words are concatenated to form one x18 bit word.
2. The x18 bit words contain demarcation bits as follows;
 - a. Bit 17 is End of Packet (EOP)
 - b. Bit 16 is Start of Packet (SOP).
3. An SOP and EOP may not occur within the same word.

Figure 34. 9bit to 18bit word configuration



6714 drw27

NOTES:

1. An SOP and EOP may not occur within the same word.
2. Bit 8 of the x9 bit even words (0,2,4, etc.) is checked for a Start of Packet (SOP).
3. Bit 8 of the x9bit odd words (1,3,5, etc.) is checked for End of Packet (EOP).
4. The minimum packet word length is 4 words.

Figure 35. 9bit to 9bit word configuration

BUS MATCHING OPERATION

Bus Matching operation between the input port and output port is available. During a master reset of the multi-queue the state of the three setup pins, BM [3:0] (Bus Matching), determine the input and output port bus widths as shown in Table 11, "Bus Matching Set-Up". 9 bit words, 18 bit words and 36 bit words can be written into and read from the Queues. When writing to or reading from the multi-queue in a bus matching mode, the device orders data in a "Little Endian" format. See Figure 36, *Bus Matching Byte Arrangement* for details.

The Full flag and Almost Full flag operation is always based on writes and reads of data widths determined by the write port width. For example, if the input port is x36 and the output port is x9, then four data reads from a full queue will be required to cause the full flag to go HIGH (queue not full). Conversely, the Empty flag and Almost Empty flag operations are always based on writes and reads of data widths determined by the read port. For example, if the input port is x18 and the output port is x36, two write operations will be required to cause the Empty flag (EF) of an empty queue to go HIGH (queue is not empty).

Note, that the input port serves all queues within a device, as does the output port, therefore the input bus width to all queues is equal (determined by the input port size) and the output bus width from all queues is equal (determined by the output port size).

TABLE 11 — BUS-MATCHING SET-UP

BM3	BM2	BM1	BM0	Write Port	Read Port
0	0	0	0	x36	x36
0	0	0	1	x36	x18
0	0	1	0	x36	x9
0	0	1	1	x18	x36
0	1	0	1	x18	x18
0	1	1	0	x18	x9
0	1	0	0	x9	x36
0	1	1	1	x9	x18
1	0	0	1	x9	x9

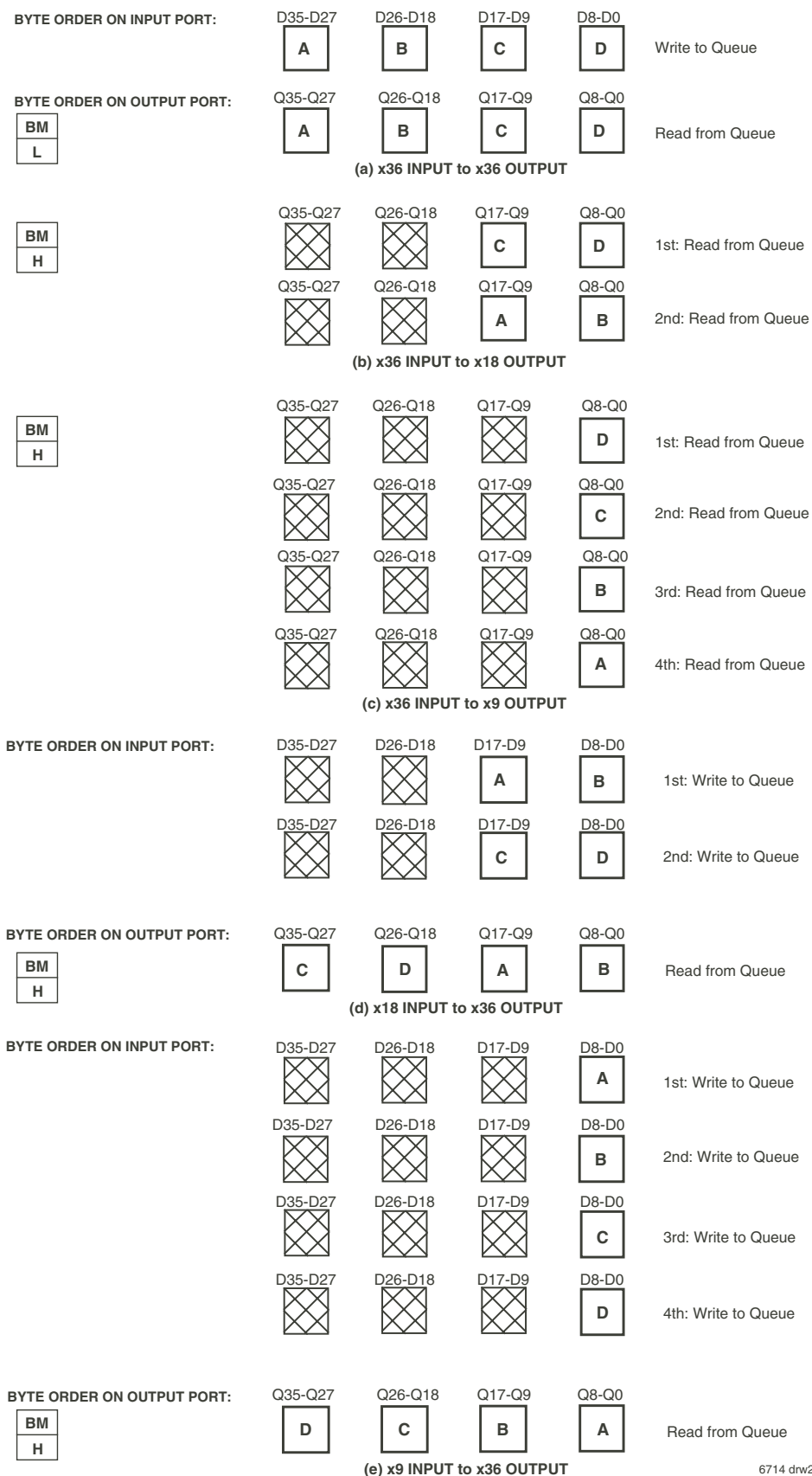

6714 dnrw28

NOTE:

1. Please refer to Table 11, Bus-Matching set-up for details.

Figure 36. Bus-Matching Byte Arrangement

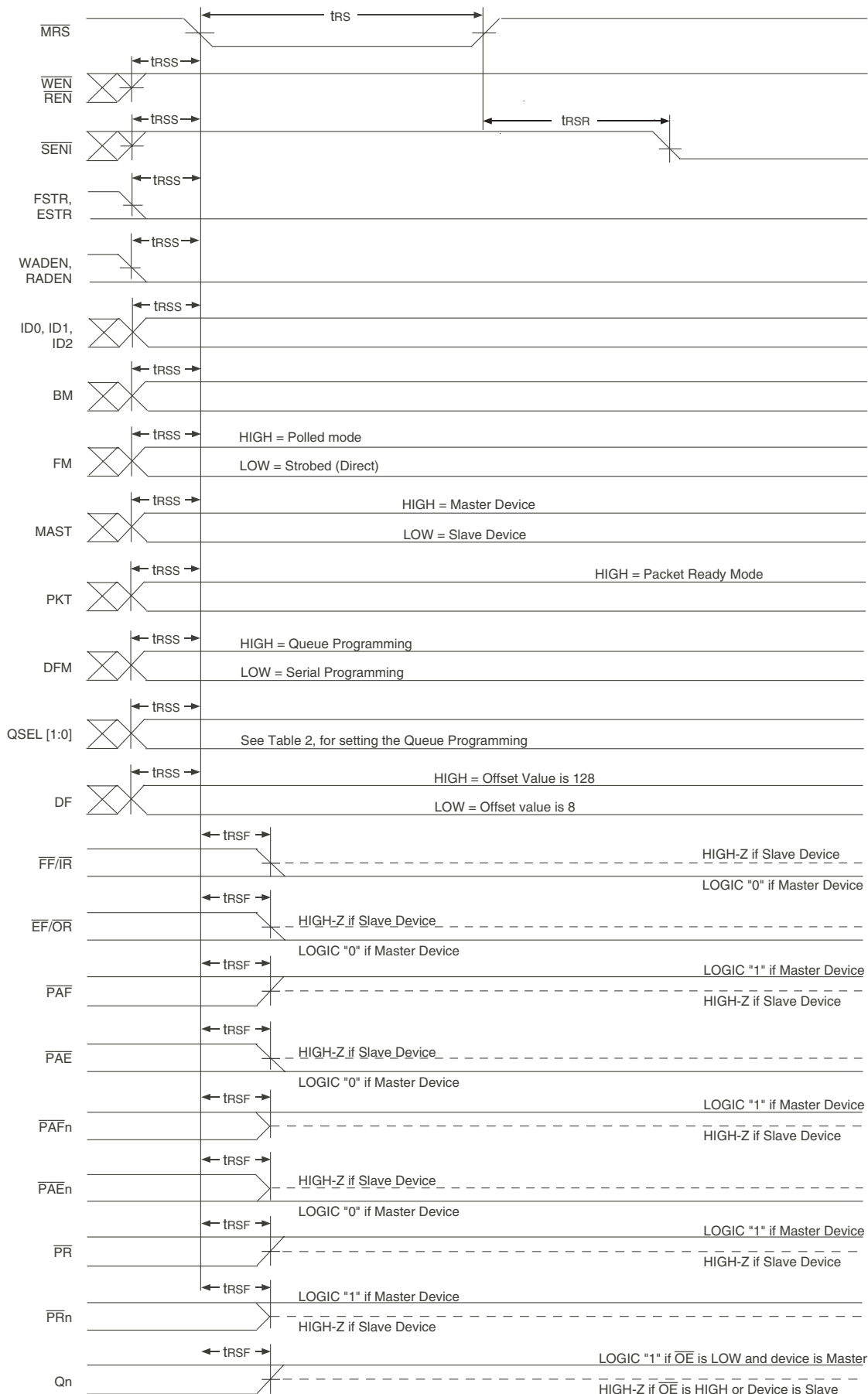

NOTE:
 1. \overline{OE} can toggle during this period.

Figure 37. Master Reset

6714 drw46

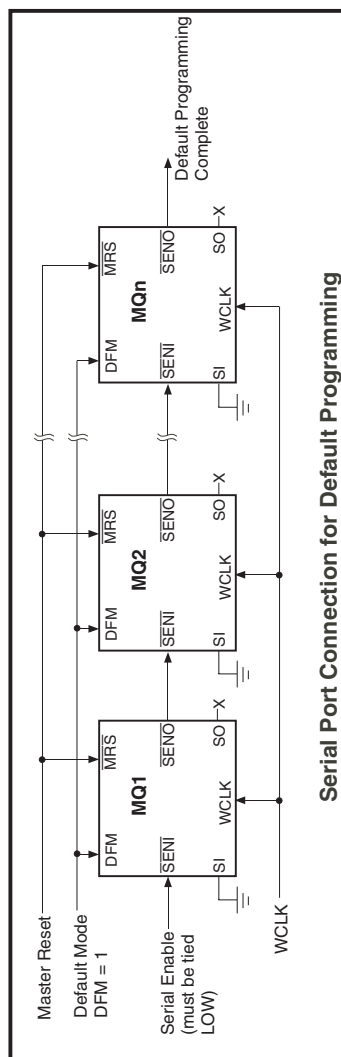
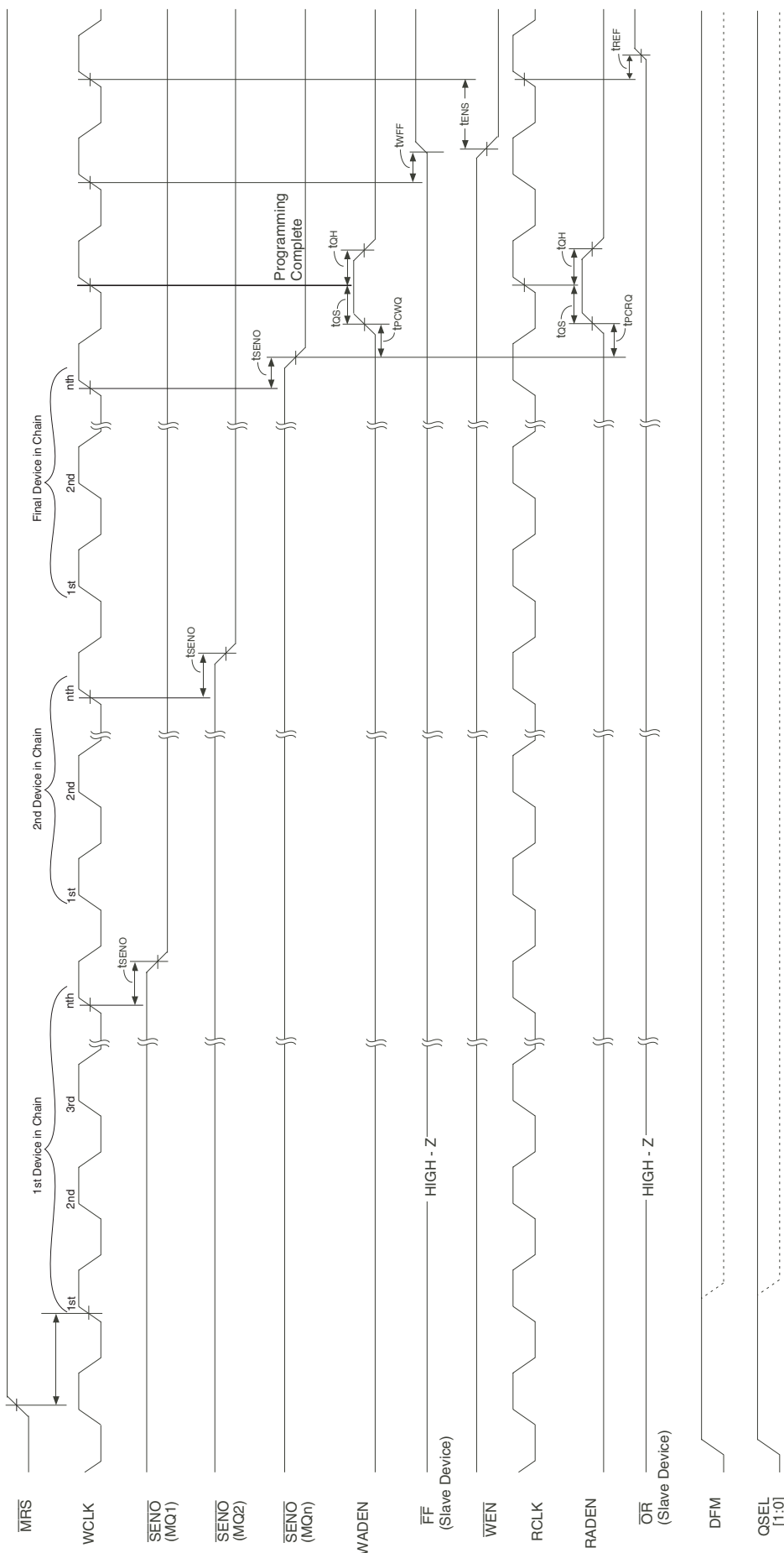

Serial Port Connection for Default Programming

6714 shw47

Figure 38. Default Programming

NOTES:

1. This diagram illustrates multiple devices connected in expansion. The SENO of the final device in a chain is the "programming complete" signal.
2. SENI of the first device in the chain must be held LOW.
3. The SENO of a device should connect to the SENI of the next device in the chain. The final device SENO is used to indicate programming complete.
4. When Default Programming is complete the SENO of the final device will go LOW. SCLK is not used and can be tied LOW.
5. Programming of all devices must be complete (SENO of the final device is LOW), before any write or read port operations can take place, this includes queue selections.

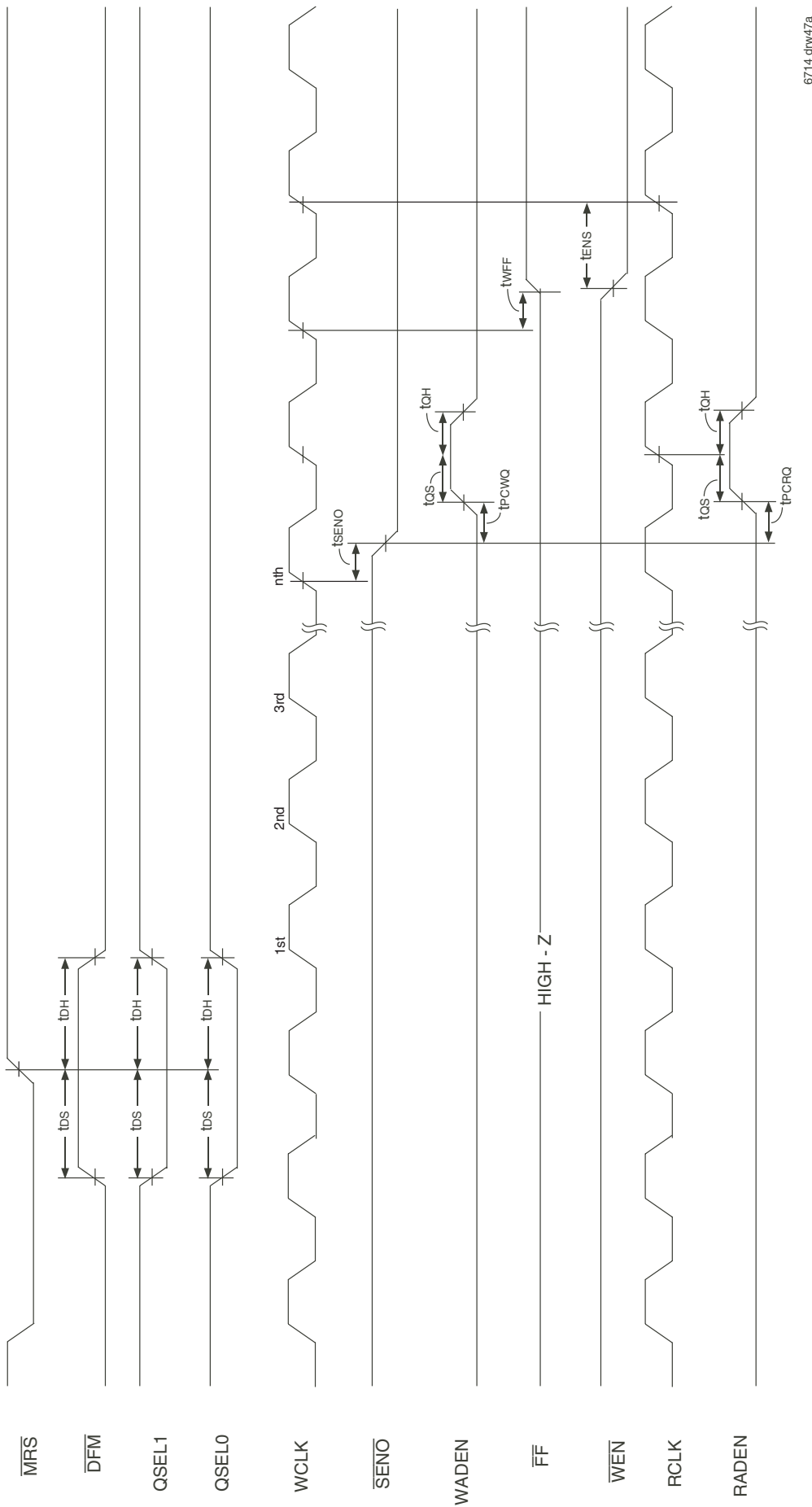

6714.dnw47a

NOTES:

1. The $\overline{SEN0}$ is the "programming complete" signal.
2. $\overline{SEN1}$ must be held LOW.
3. When Parallel Programming is complete the $\overline{SEN0}$ of the device will go LOW.
4. SCLK is not used and can be tied LOW.
5. Programming of the device must be complete ($\overline{SEN0}$ of the device is LOW), before any write or read port operations can take place, this includes queue selections.

Figure 39. Parallel Programming

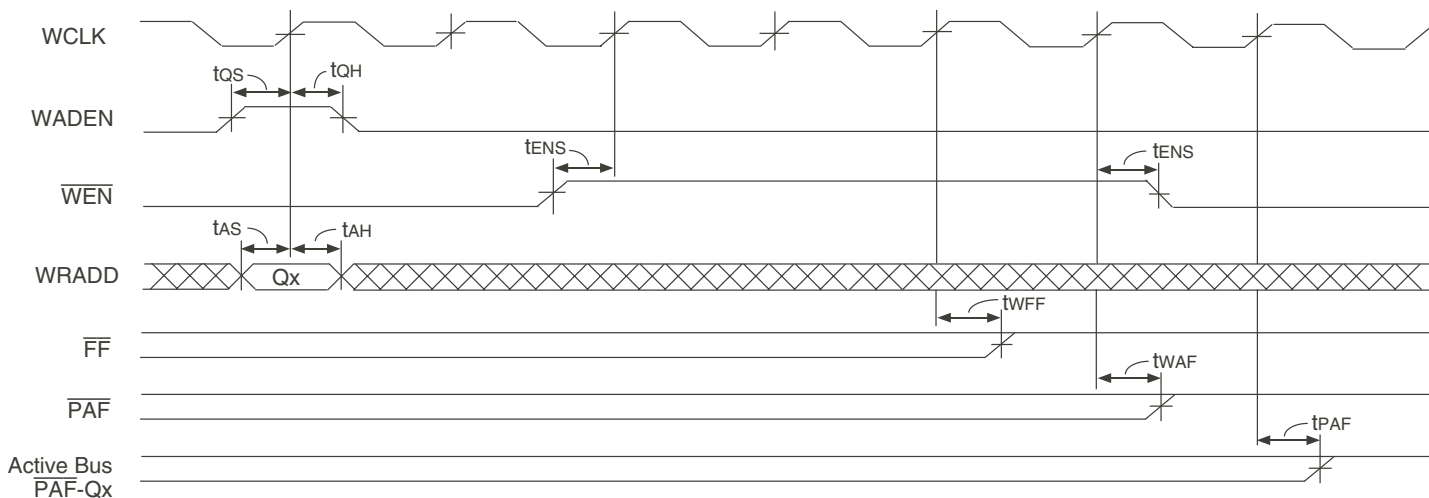

Figure 40. Queue Programming via Write Address Bus

6714 drw48

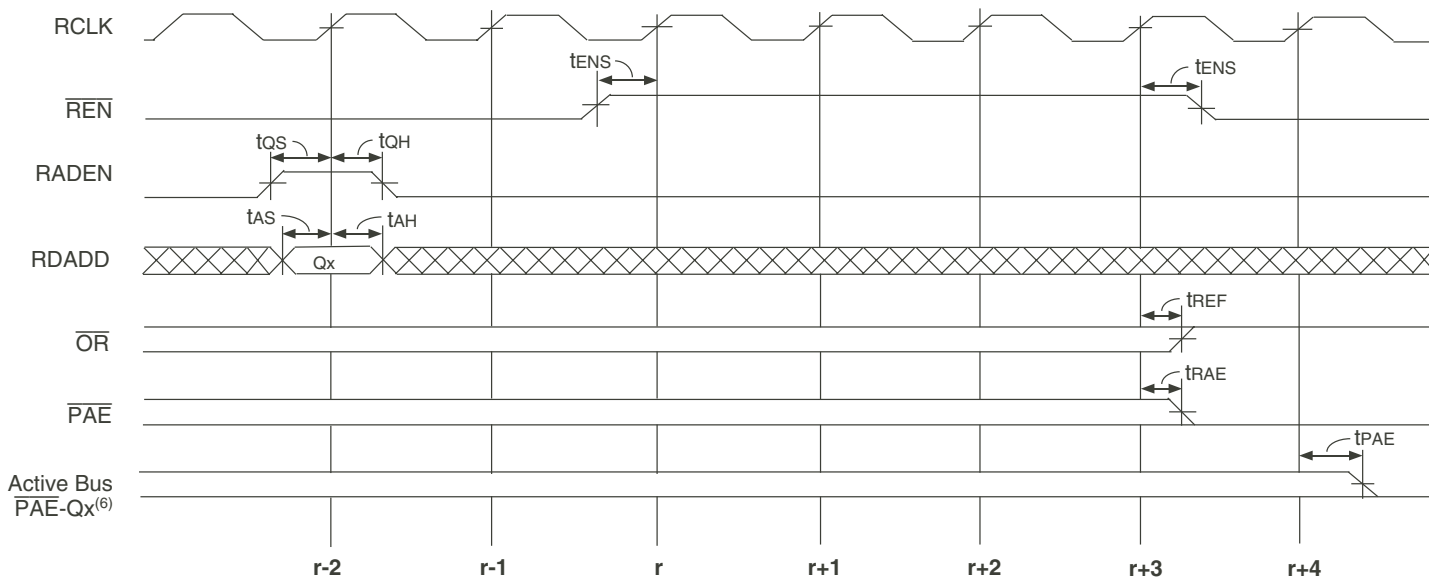

Figure 41. Queue Programming via Read Address Bus

6714 drw49

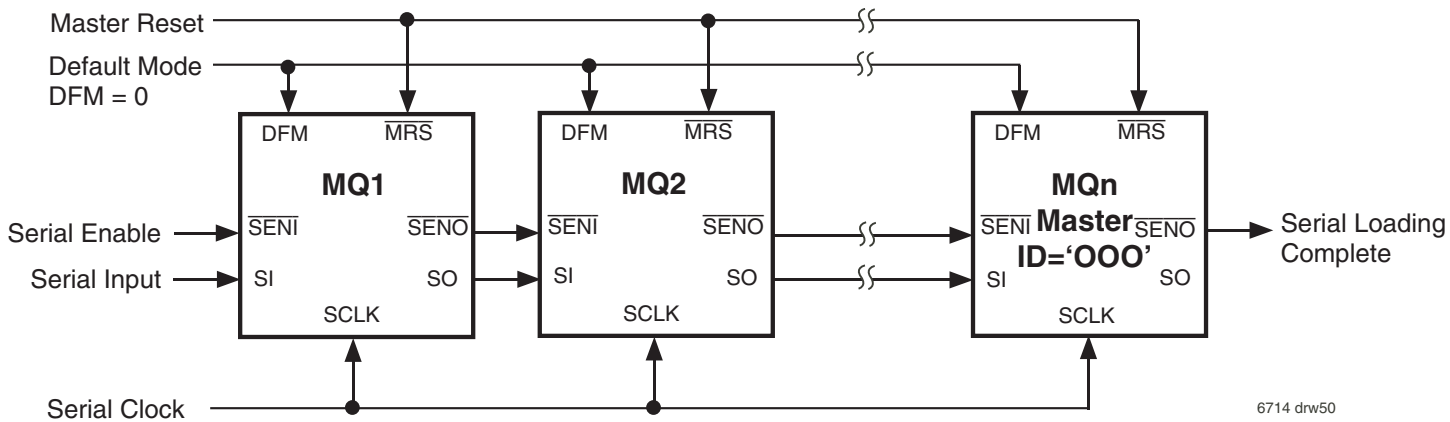
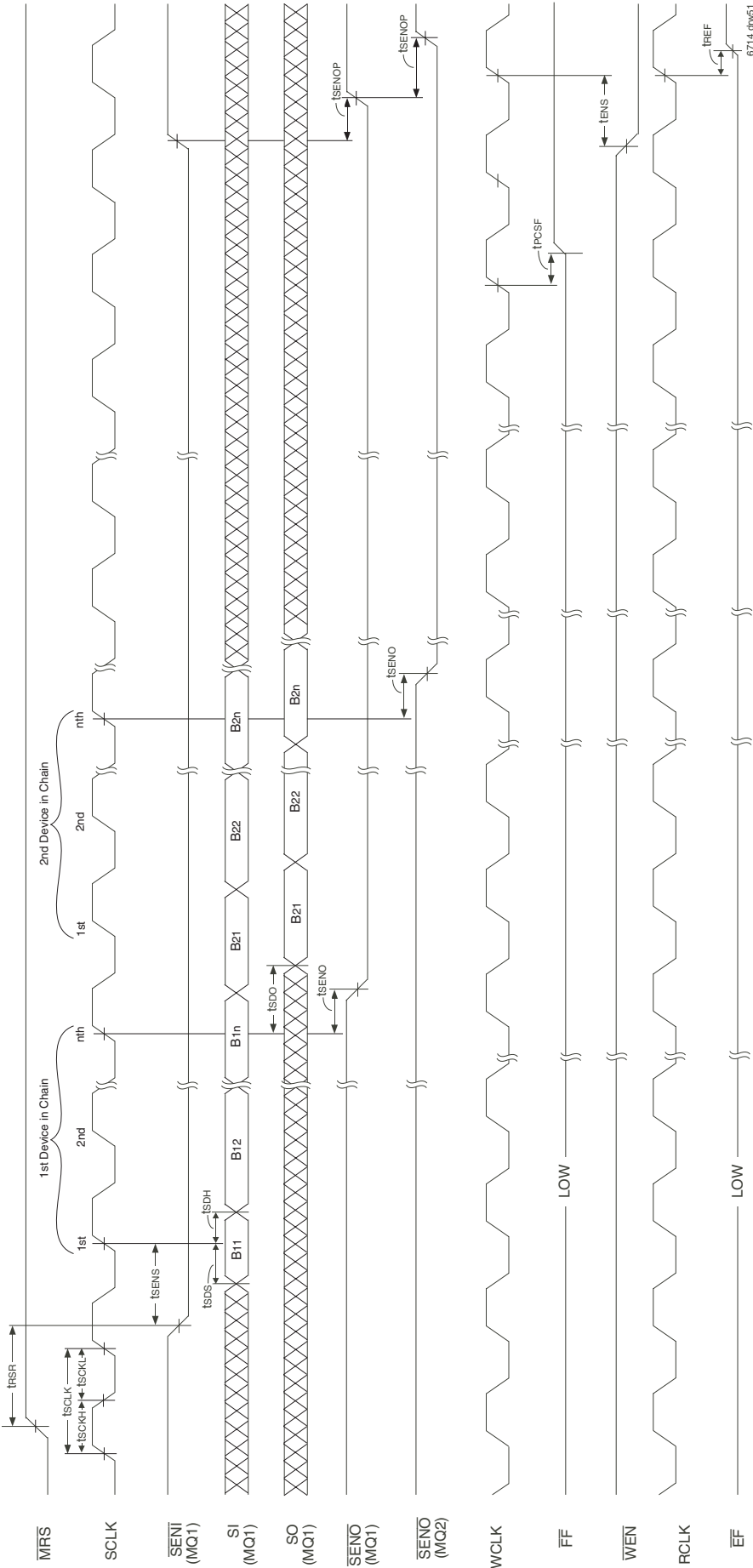

Figure 42. Serial Port Connection for Serial Programming

6714 drw50



NOTES:

1. \overline{SENI} can be toggled during serial loading. Once serial programming of a device is complete, the \overline{SENI} and SI inputs become transparent. $\overline{SENI} \rightarrow \overline{SENO}$ and SI \rightarrow SO.
2. DFM is LOW and OSEL0 = HIGH, OSEL1 = HIGH during Master Reset to provide Serial programming mode, DF is don't care.
3. When \overline{SENO} of the final device is LOW no further serial loads will be accepted.
4. $n = 19 + (Q \times 72)$; where Q is the number of queues required for the IDT72P51749/72P51759/72P51769.
5. Programming of all devices must be complete (\overline{SENO} of the 2nd device is LOW), before any write or read port operations can take place, this includes queue selections.

Figure 43. Serial Programming (2 Device Expansion)

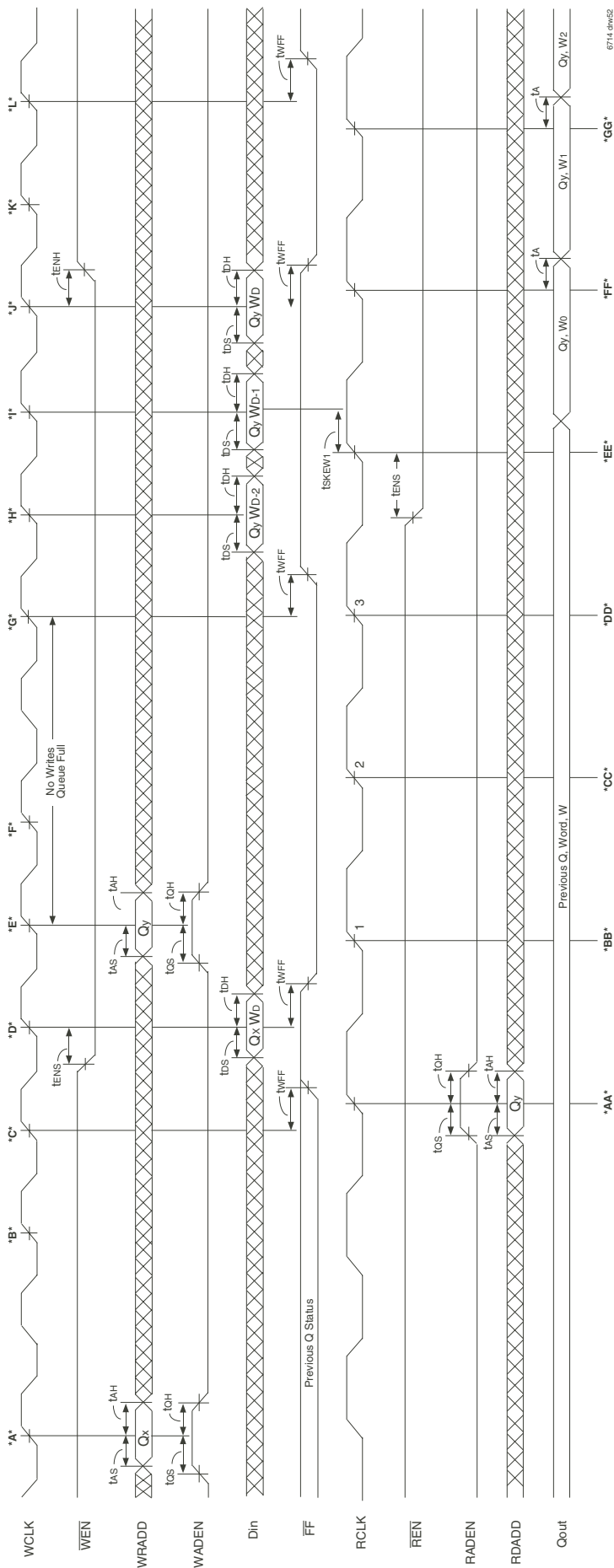

NOTE:

OE is active LOW.

Cycle:

- *A* Queue, Ox is selected on the write port.
The FF flag is providing status of a previously selected queue, within the same device.
- *AA* Queue, Oy is selected for read operations.
- *B* The FF flag provides status of previous queue for 3 WCLK cycles.
- *BB* Current word is kept on the output bus since REN is HIGH.
- *C* The FF flag output updates to show the status of Ox, it is not full.
- *CC* Word W+1 is read from the previous queue regardless of REN due to FWFT.
- *D* Word, Wd is written into Ox. This causes Ox to go full.
- *DD* The next available Word W0 of Oy is read out regardless of REN, 3 RCLK cycles after queue selection. This is FWFT operation.
- *E* Queue, Oy is selected within the same device as Ox. A write to Ox cannot occur on this cycle because it is full, FF is LOW.
- *EE* No reads occur, REN is HIGH. Word, W0 is read from Oy, this causes Oy to go "not full", FF flag goes HIGH after time, tSKEW1 + tWFF. Note, if tSKEW1 is violated the time FF HIGH will be: tSKEW1 + WCLK + tWFF.
- *F* Again, a write to Ox cannot occur on this cycle because it is full, FF is LOW.
- *FF* Word, W1 is read from Oy.
- *G* The FF flag updates after time tWFF to show that queue, Oy is not full.
- *H* Word, Wd-2 is written into Oy.
- *I* Word, Wd-1 is written into Oy.
- *J* Word, Wd is written into Oy, this causes Oy to go full, FF goes LOW.
- *K* A write to Oy cannot occur on this cycle because it is full, FF is LOW.
- *L* Oy goes "not full" based on reading word W1 from Oy on cycle *FF*.

Figure 44. Write Queue Select, Write Operation and Full Flag Operation

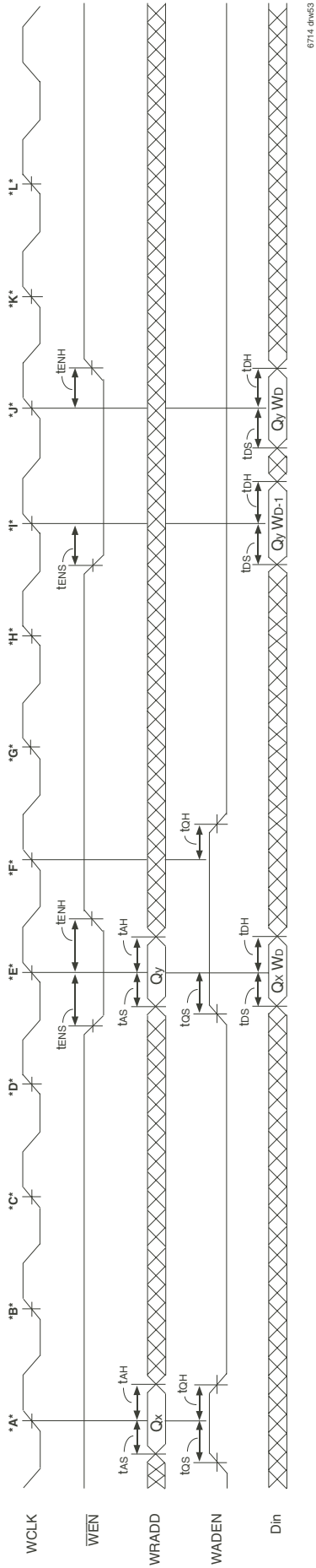

6714.drv63

NOTES:

1. Only 1 queue can be marked at any given time.
2. Marking a queue can only occur during a queue switch.

Cycle:

- *A* Queue "X" is selected but not marked.
- *E* Queue "Y" is selected and marked.

Figure 45. Write Queue Select and Mark

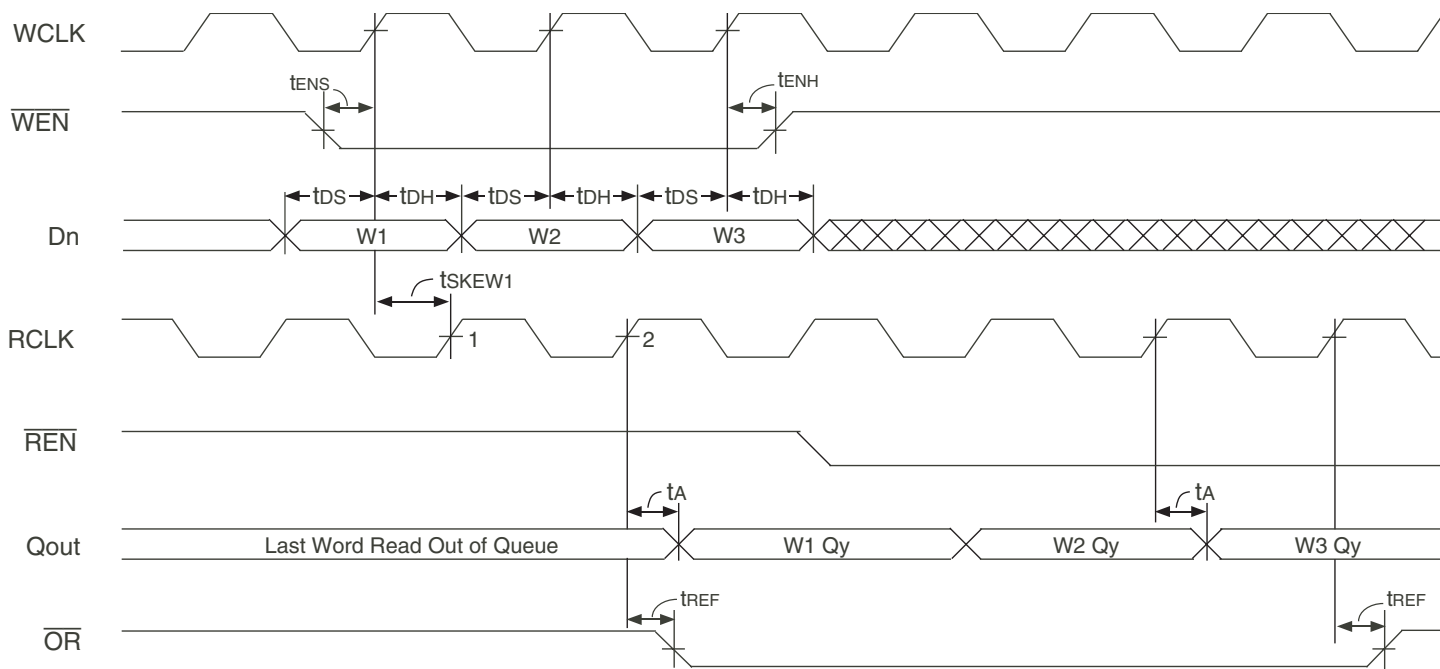

6714 drw54

NOTES:

1. Qy has previously been selected on both the write and read ports.
2. \overline{OE} is LOW.
3. The First Word Latency = tSKEW1 + RCLK + tA. If tSKEW1 is violated an additional RCLK cycle must be added.

Figure 46. Write Operations in First Word Fall Through mode

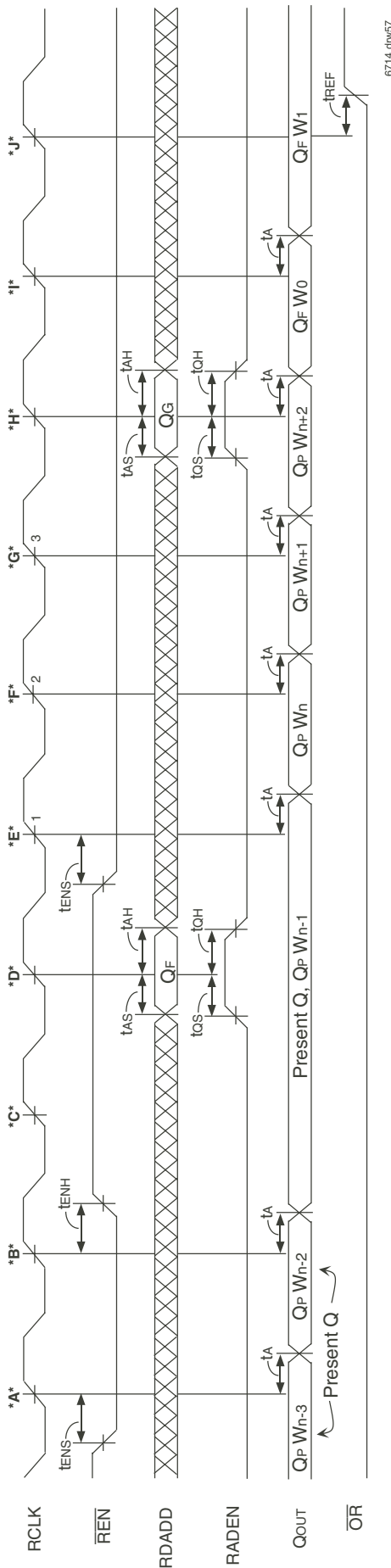

Cycle:

- *A* Word Wn-2 is read from a previously selected queue Qp on the read port.
- *B* Wn-1 is read out.
- *C* Reads are disabled, Wn-1 remains on the output bus.
- *D* A new queue, QF is selected for read operations.
- *E* Word Wn in Qp is read out.
- *F* Wn+1 is read out.
- *G* Wn+2 is read out.
- *H* The next word available in the new queue, QF=Wo falls through to the output bus regardless of REN. A new queue, QG is selected for read operations.
- *I* QF W1 is read out.
- *J* Word W1 from QF remains on the output bus because QF is empty. The Output Ready Flag, OR goes HIGH to indicate that the current word is not valid, i.e. QF is empty.

Figure 49. Read Queue Select, Read Operation (FWFT mode)

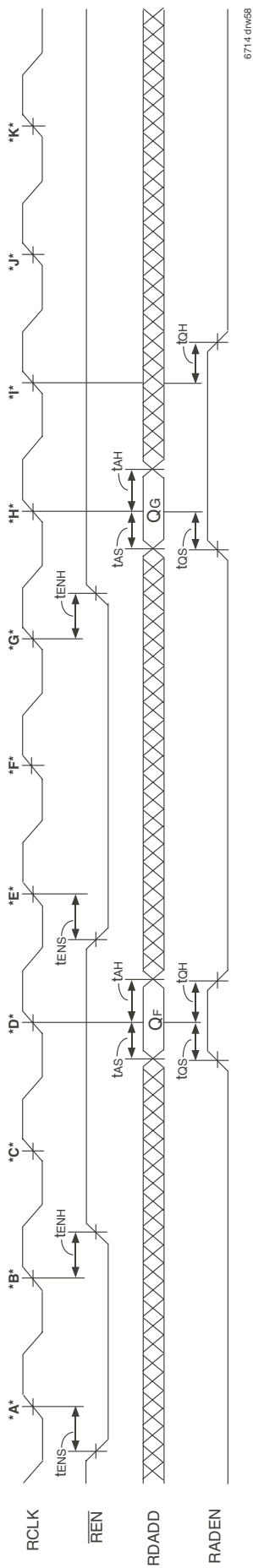

NOTES:

1. Only 1 queue can be marked at any given time.
2. Marking a queue can only occur during a queue switch.

Cycle:

- *D* Queue "F" is selected but not marked.
- *H* Queue "G" is selected and marked.

Figure 50. Read Queue Select and Mark (IDT mode)

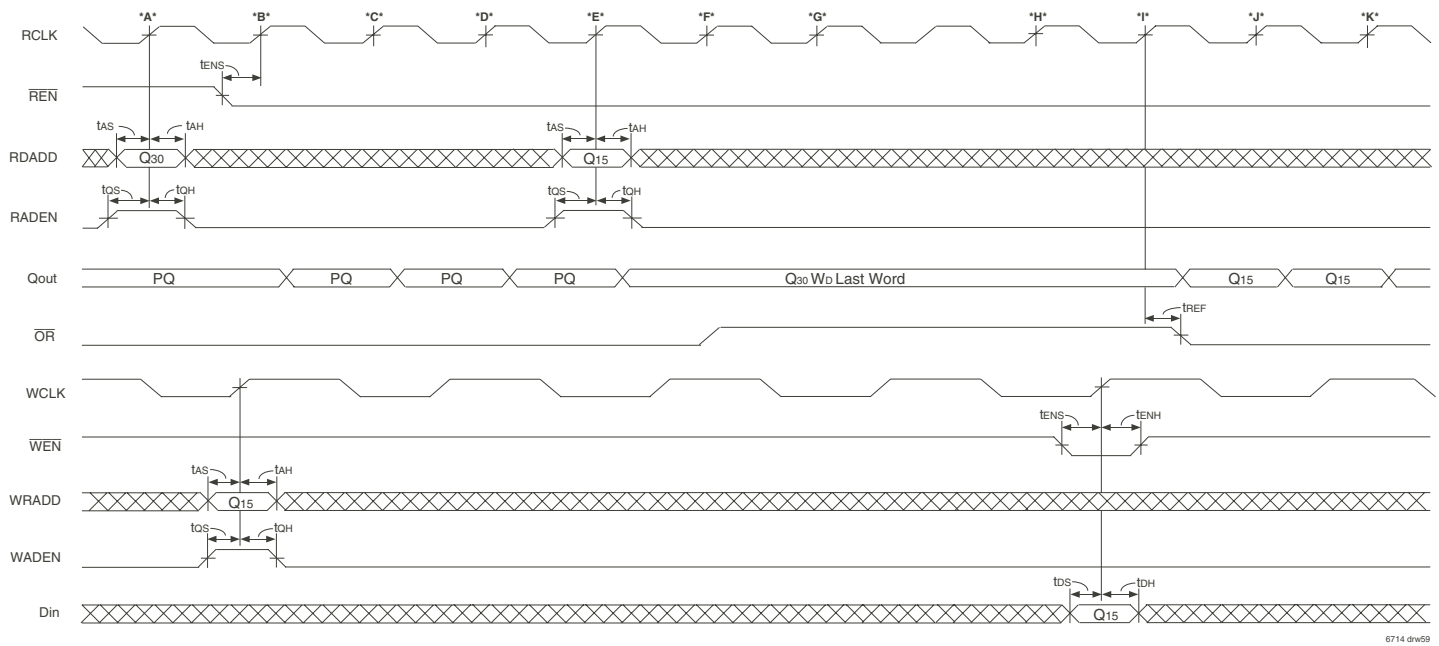

Cycle:

- *A* Queue 30 is selected for read operations. It requires 4 clock cycles to switch queues.
- *B* Reads are now enabled. A word from the previously selected queue will be read out.
- *C* Another word from Present Queue (PQ) is read.
- *D* Another word from PQ is read.
- *E* Wd is read from Q30 of D1. This happens to be the last word of Q30, therefore \overline{OR} goes HIGH to indicate that the data on the Qout is not valid (Q30 was read to empty). Word, Wd remains on the output bus. Queue 15 is selected for read operations.
- *F* The last word of Q30 remains on the Qout bus, \overline{OR} is HIGH, indicating that this word has been previously read.
- *G* The last word of queue 30 remains on the Qout bus.
- *H* The last word of queue 30 remains on the Qout bus.
- *I* The next word, available from the newly selected queue, Q15 is now read out. This will occur regardless of \overline{REN} , due to FWFT mode.
- *J* A word, is read from Q15.
- *K* The \overline{OR} flag stays LOW to indicate that Q15 has additional words available for reading.

Figure 51. Output Ready Flag Timing (In FWFT Mode)

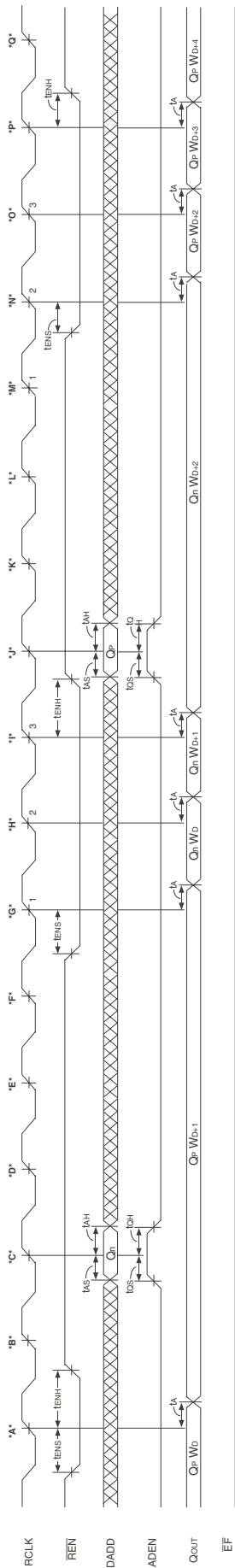

67141awds

Cycle:

- *A* Word Wd+1 is read from the present selected queue, Qp.
- *B* Reads are disabled, word Wd+1 remains on the output bus.
- *C* A new queue, Qn is selected for read operations. Qp Wb+1 remains on Oout bus.
- *D* REN is not asserted therefore no read operation occurs, Qp Wb+1 remains on Oout bus.
- *E* REN is not asserted therefore no read operation occurs, Qp Wb+1 remains on Oout bus.
- *F* REN is not asserted therefore no read operation occurs, Qp Wb+1 remains on Oout bus.
- *G* Word Wd of Qn is read out.
- *H* Word Wd+1 of Qn is read out.
- *I* Word Wb+2 of Qn is read out.
- *J* The queue, Qp is again selected.
- *K* Current Word is kept on the output bus since REN is HIGH.
- *L* Word On Wb+2 remains on the Oout bus.
- *M* Word On Wb+2 remains on the Oout bus.
- *N* Word Wd+2 is read from Qp.
- *O* Word Wb+3 for Qp is read out.
- *P* Word Wb+4 for Qp is read out.

Figure 52. Read Queue Selection with Read Operations (IDT mode)

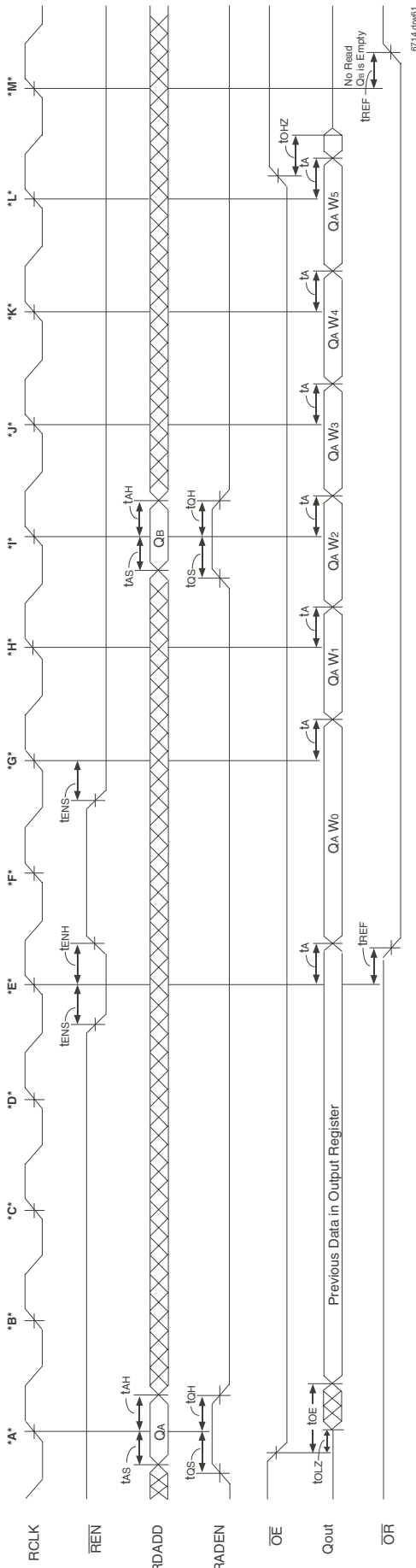

NOTES:

1. The Output Ready flag, \overline{OR} is HIGH therefore the previously selected queue has been read to empty. The Output Enable input is Asynchronous, therefore the Qout output bus will go to Low-Impedance after time tOLZ.
 The data currently in the output register will be available on the output bus (Qout) after time tOE.

2. In expansion configuration the \overline{OE} inputs of all devices should be connected together. This allows the output busses of all devices to be High-Impedance controlled.

Cycle:

- *A* Queue A is selected for reads. No data will fall through on this cycle, the previous queue was read to empty.
- *B* No data will fall through on this cycle, the previous queue was read to empty.
- *C* Previous data kept on output bus since there is no read operation.
- *D* Previous data kept on output bus since there is no read operation.
- *E* Word, W0 from QA is read out regardless of REN due to FWFT operation. The \overline{OR} flag goes LOW indicating that Word W0 is valid.
- *F* Reads are disabled therefore word, W0 of QA remains on the output bus.
- *G* Reads are again enabled so word W1 is read from QA.
- *H* Word W2 is read from QA.
- *I* Queue, QB is selected on the read port. This queue is actually empty. Word, W3 is read from QA.
- *J* Word, W4 is read from QA.
- *K* Word W5 is read from QA.
- *L* Output Enable is taken HIGH, this is Asynchronous so the output bus goes to High-impedance after time, tOHZ.
- *M* Output Ready flag, \overline{OR} goes HIGH to indicate that QB is empty. Data on the output port is no longer valid.

Figure 53. Read Queue Select, Read Operation and \overline{OE} Timing

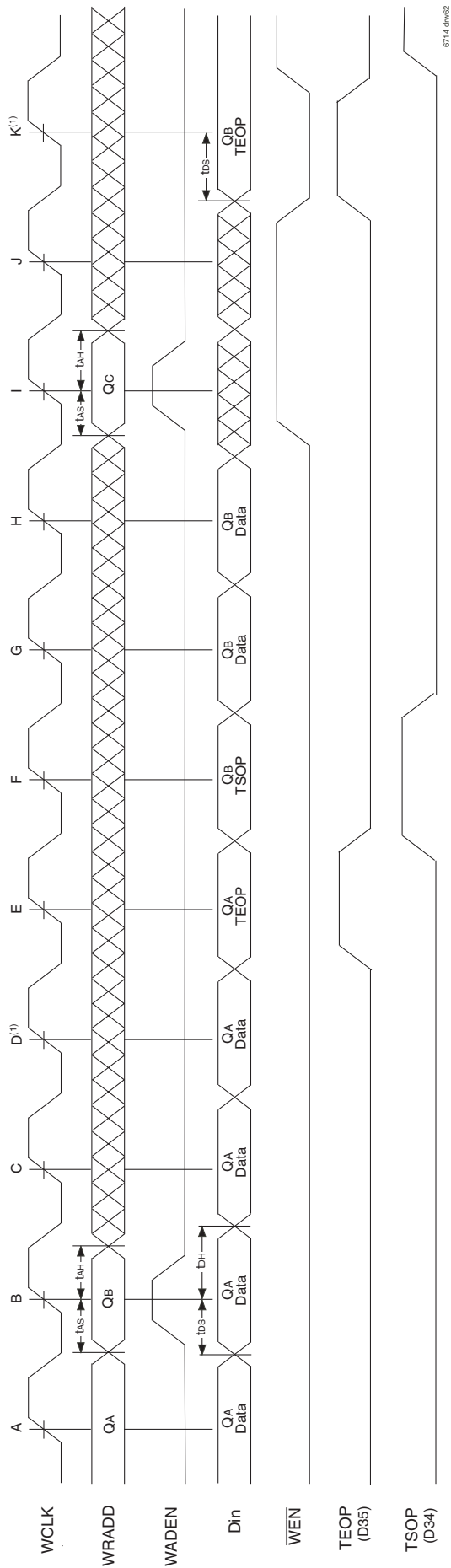

6714.dwg2

NOTES:

1. Minimum allowable packet size is four (4) 36 bit words or equivalent.
2. Maximum allowable packet size is the depth of the queue.
3. TSOP and TEOP may not be a "1" in the same word.

Figure 54. Writing in Packet Mode during a Queue change

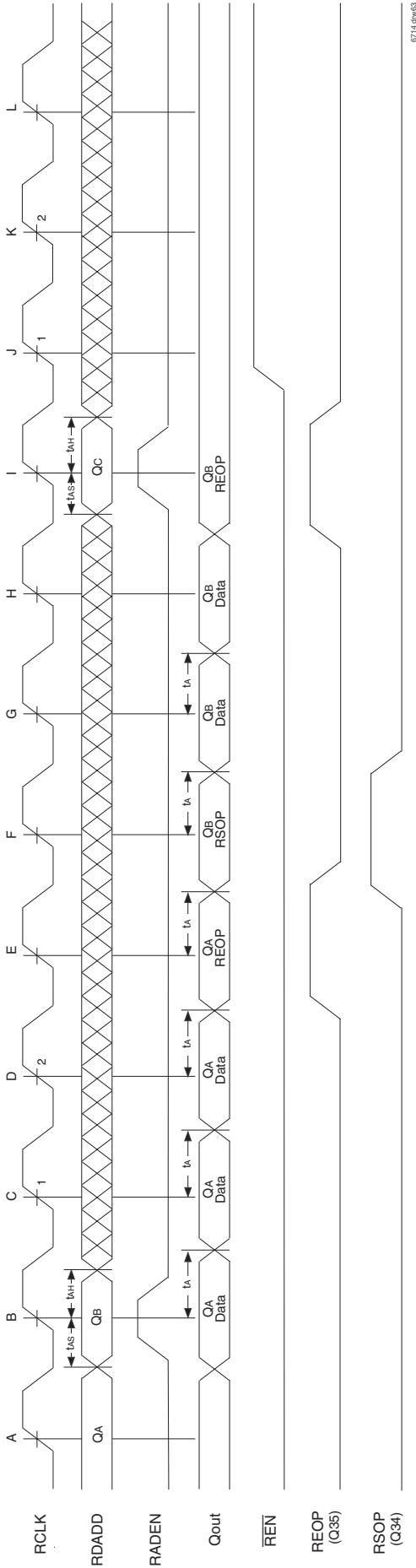
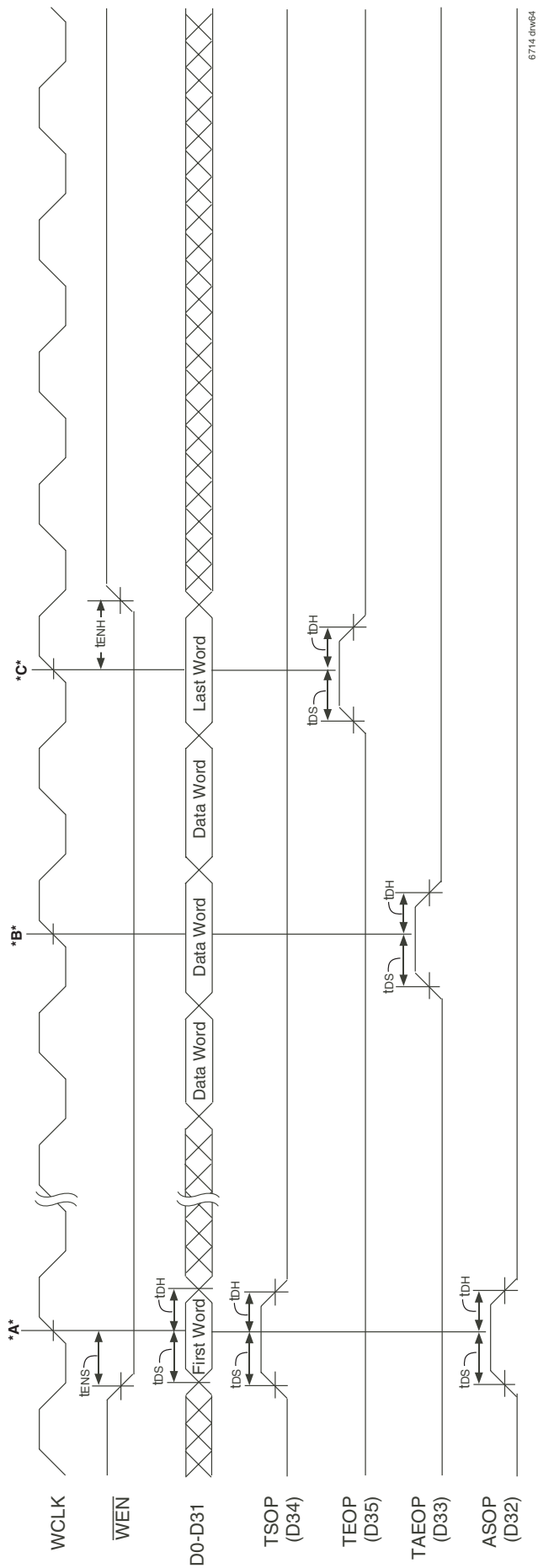

Figure 55. Reading in Packet Mode during a Queue change

6714.dwg/03



6714 dhw64

NOTES:

1. Device is configured in packet mode.
2. REN is HIGH.
3. If ISKEW4 is violated \overline{PR} may take one additional RCLK cycle.
4. \overline{PR} will always go LOW on the same cycle or 1 cycle ahead of \overline{OR} going LOW, (assuming the last word of the packet is the last word in the queue).
5. In Packet mode, words cannot be read from a queue until a complete packet has been written into that queue, regardless of REN.

Figure 56. Writing Demarcation Bits (Packet Mode)

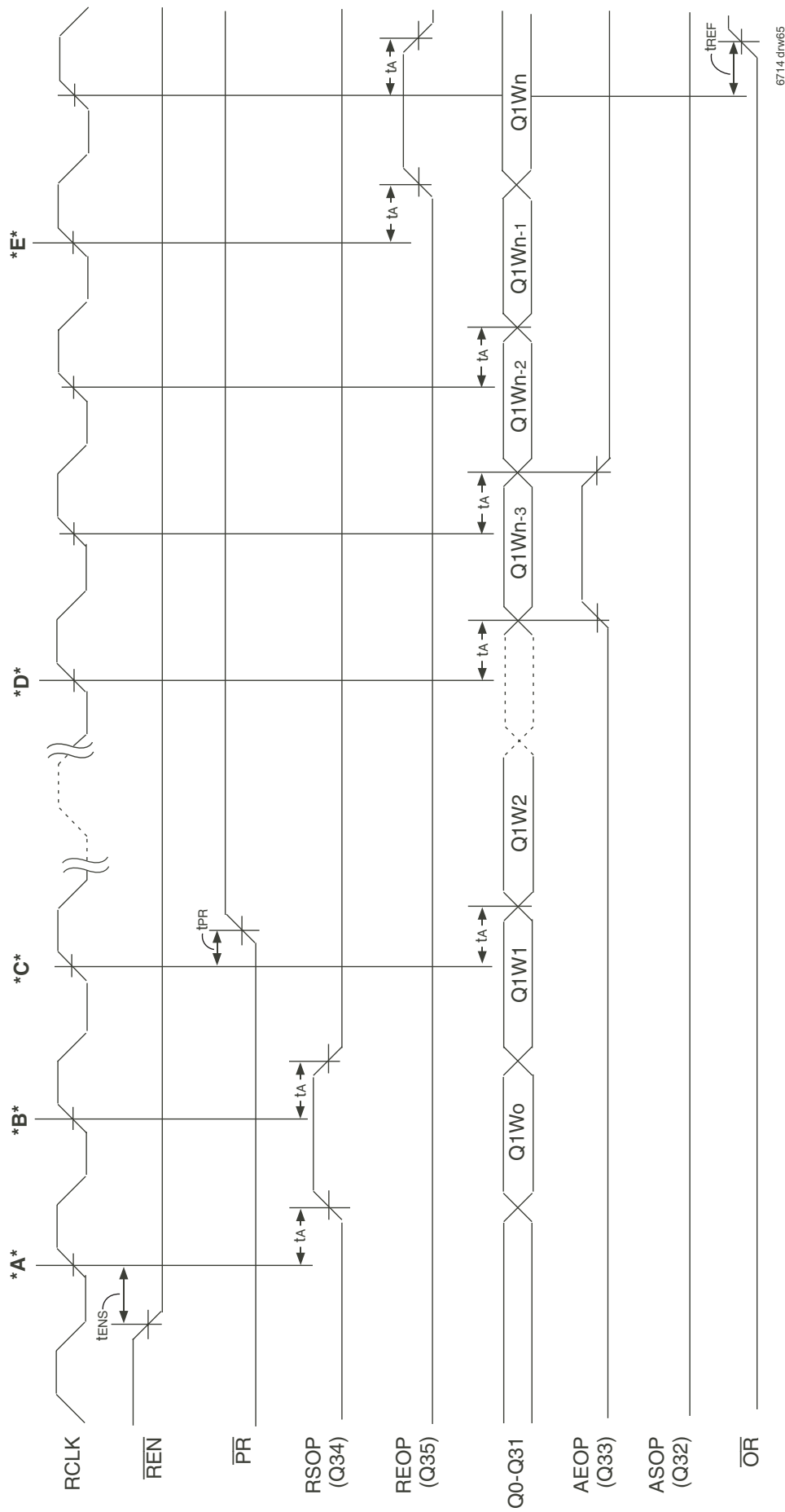

6714 dtw65

NOTE:

1. In Packet mode, words cannot be read from a queue until a complete packet has been written into that queue, regardless of **REN**.
2. The **PR** flag will go HIGH on cycle "C" regardless of **REN**.
3. The **OR** flag will go HIGH (preventing further reads), when the last complete packet has been read out. If there is a partial packet (an incomplete packet) in the queue the **OR** flag will remain HIGH until further writes have completed the packet.

Figure 57. Data Output (Receive) Packet Mode of Operation

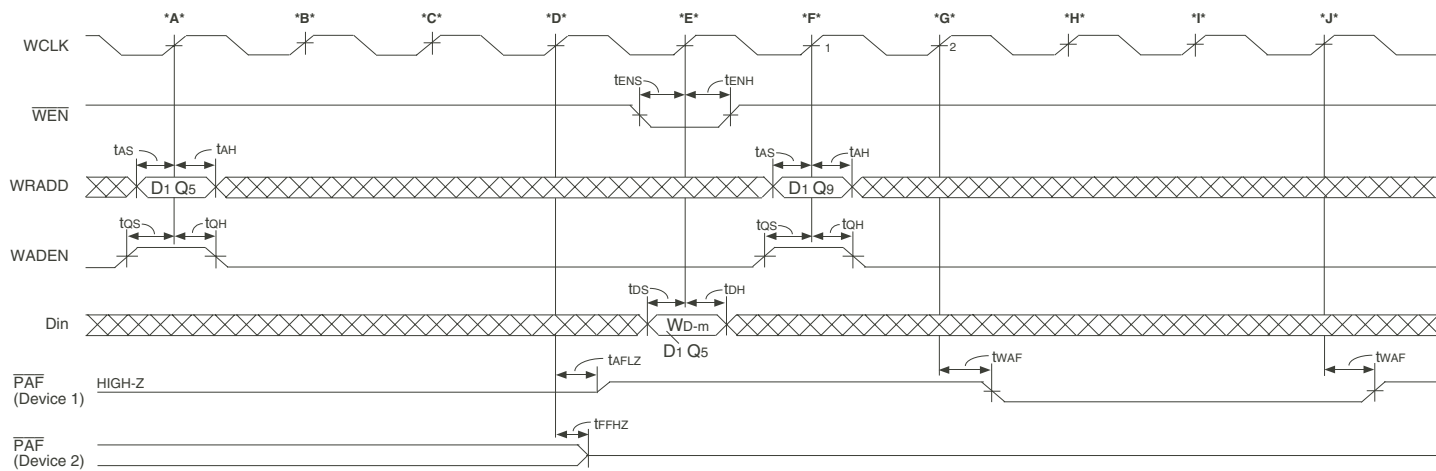

6714 drw66

Cycle:

- *A* Queue 5 of Device 1 is selected on the write port. A queue within Device 2 had previously been selected. The $\overline{\text{PAF}}$ output of device 1 is High-Impedance.
- *B* No write occurs, $\overline{\text{WEN}}$ is HIGH.
- *C* No write occurs, $\overline{\text{WEN}}$ is HIGH.
- *D* No write occurs, $\overline{\text{WEN}}$ is HIGH.
- *E* Word, Wd-m is written into Q5 causing the $\overline{\text{PAF}}$ flag to go from LOW to HIGH. The flag latency is 3 WCLK cycles + twAF.
- *F* Queue 9 in device 1 is now selected for write operations. This queue is not almost full, therefore the $\overline{\text{PAF}}$ flag will update after a 3 WCLK + twAF latency.
- *G* The PAF flag goes LOW based on the write 2 cycles earlier.
- *H* No write occurs, $\overline{\text{WEN}}$ is HIGH.
- *I* The $\overline{\text{PAF}}$ flag goes HIGH due to the queue switch to Q9.

Figure 58. Almost Full Flag Timing and Queue Switch

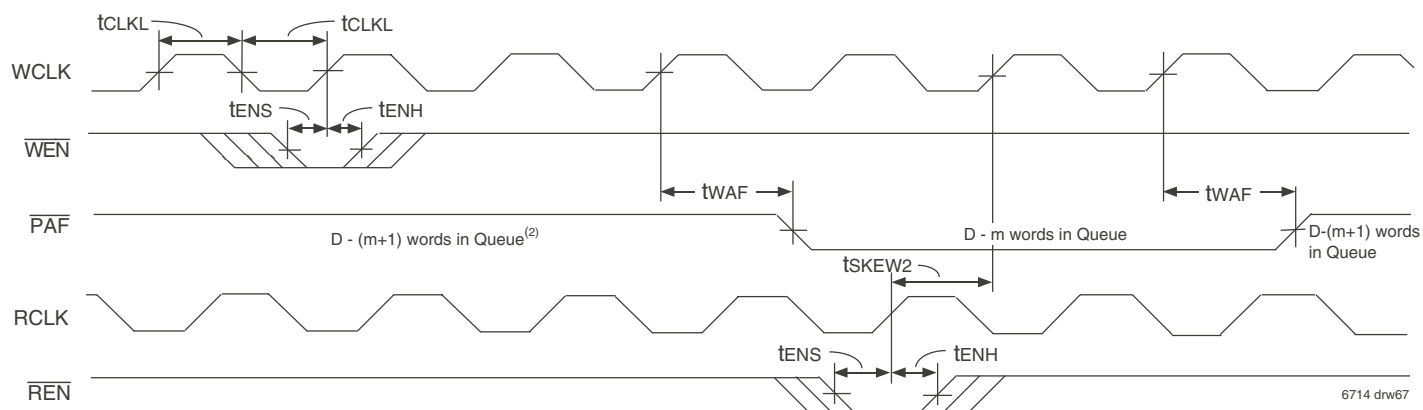

6714 drw67

NOTE:

1. The waveform shows the $\overline{\text{PAF}}$ flag operation when no queue switch occurs and a queue is selected on both the write and read ports is being written to then read from at the almost full boundary.
2. Flag Latencies:
Assertion: $2 \cdot \text{WCLK} + \text{twAF}$
De-assertion: $\text{tsKEW2} + \text{WCLK} + \text{twAF}$
3. If tsKEW2 is violated there will be one extra WCLK cycle.

Figure 59. Almost Full Flag Timing

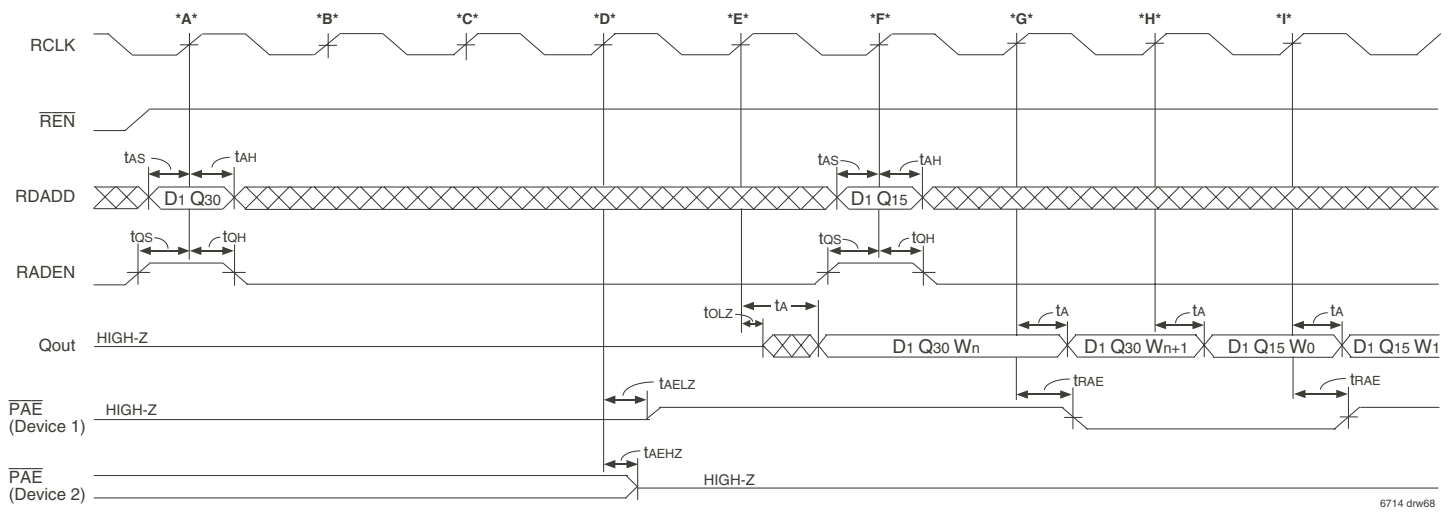

- Cycle:
- *A* Queue 30 of Device 1 is selected on the read port. A queue within Device 2 had previously been selected. The $\overline{\text{PAE}}$ flag output and the data outputs of device 1 are High-Impedance.
 - *B* No read occurs, $\overline{\text{REN}}$ is HIGH.
 - *C* No read occurs, $\overline{\text{REN}}$ is HIGH.
 - *D* No read occurs, $\overline{\text{REN}}$ is HIGH
 - *E* The $\overline{\text{PAE}}$ flag output now switches to device 1. Word, W_n is read from Q30 due to the FWFT operation. This read operation from Q30 is at the almost empty boundary, therefore $\overline{\text{PAE}}$ will go LOW 2 RCLK cycles later.
 - *F* Q15 of device 1 is selected.
 - *G* The $\overline{\text{PAE}}$ flag goes LOW due to the read from Q30 2 RCLK cycles earlier. Word W_{n+1} is read out due to the FWFT operation.
 - *H* Word, W_0 is read from Q15 due to the FWFT operation.
 - *I* The $\overline{\text{PAE}}$ flag goes HIGH to show that Q15 is not almost empty.

Figure 60. Almost Empty Flag Timing and Queue Switch (FWFT mode)

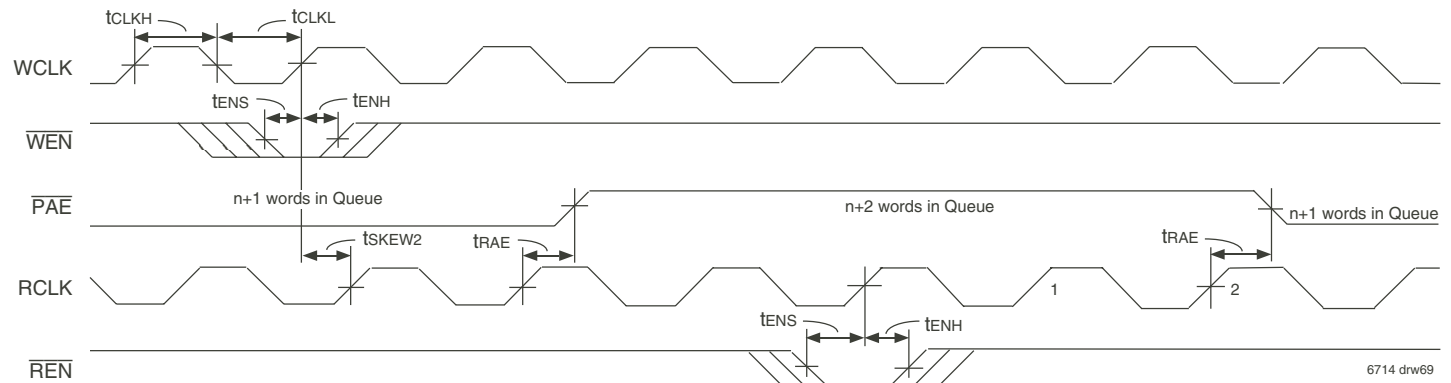

- NOTE:
1. The waveform here shows the $\overline{\text{PAE}}$ flag operation when no queue switches are occurring and a queue selected on both the write and read ports is being written to then read from at the almost empty boundary.
 Flag Latencies:
 2. Assertion: $2 \cdot \text{RCLK} + \text{trAE}$
 De-assertion: $\text{tsKEW2} + \text{RCLK} + \text{trAE}$
 3. If tsKEW2 is violated there will be one extra RCLK cycle.

Figure 61. Almost Empty Flag Timing

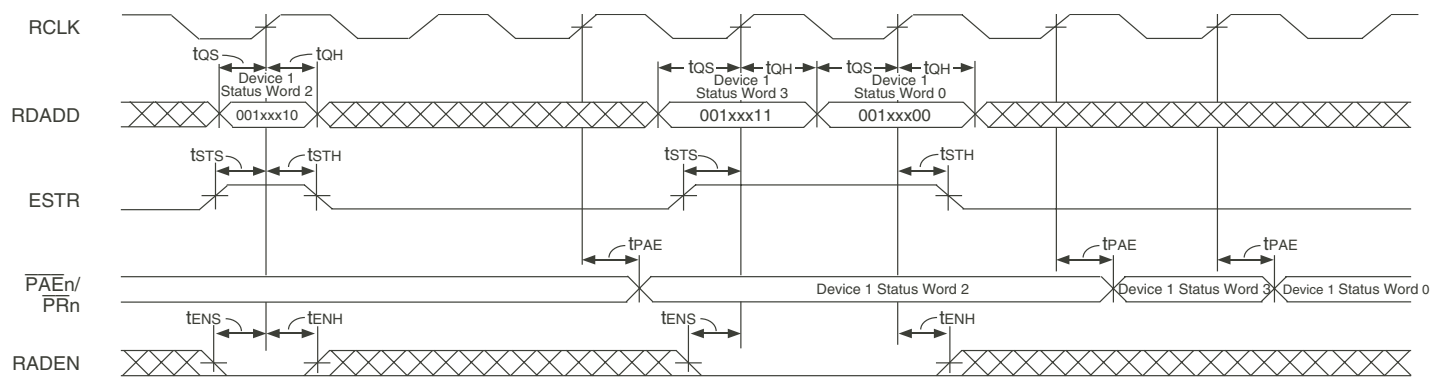

6714 drw70

NOTES:

1. Status words can be selected on consecutive cycles.
2. On an RCLK cycle that the ESTR is HIGH, the RADEN input must be LOW.
3. There is a latency of 2 RCLK for the PAEn bus to switch.

Figure 62. PAEn/PRn - Direct Mode - Status Word Selection

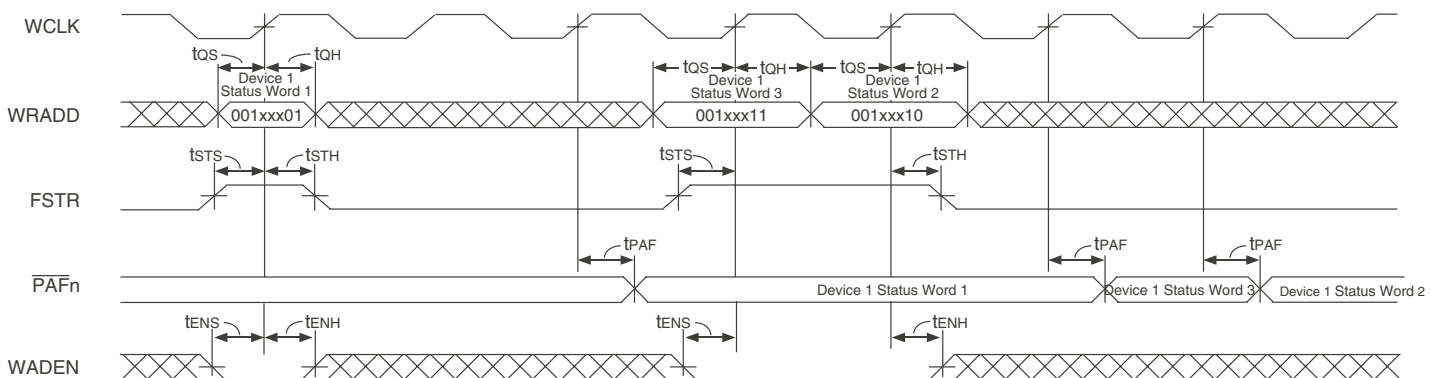

6714 drw71

NOTES:

1. Status words can be selected on consecutive cycles.
2. On a WCLK cycle that the FSTR is HIGH, the WADEN input must be LOW.
3. There is a latency of 2 WCLK for the PAFn bus to switch.

Figure 63. PAFn - Direct Mode - Status Word Selection

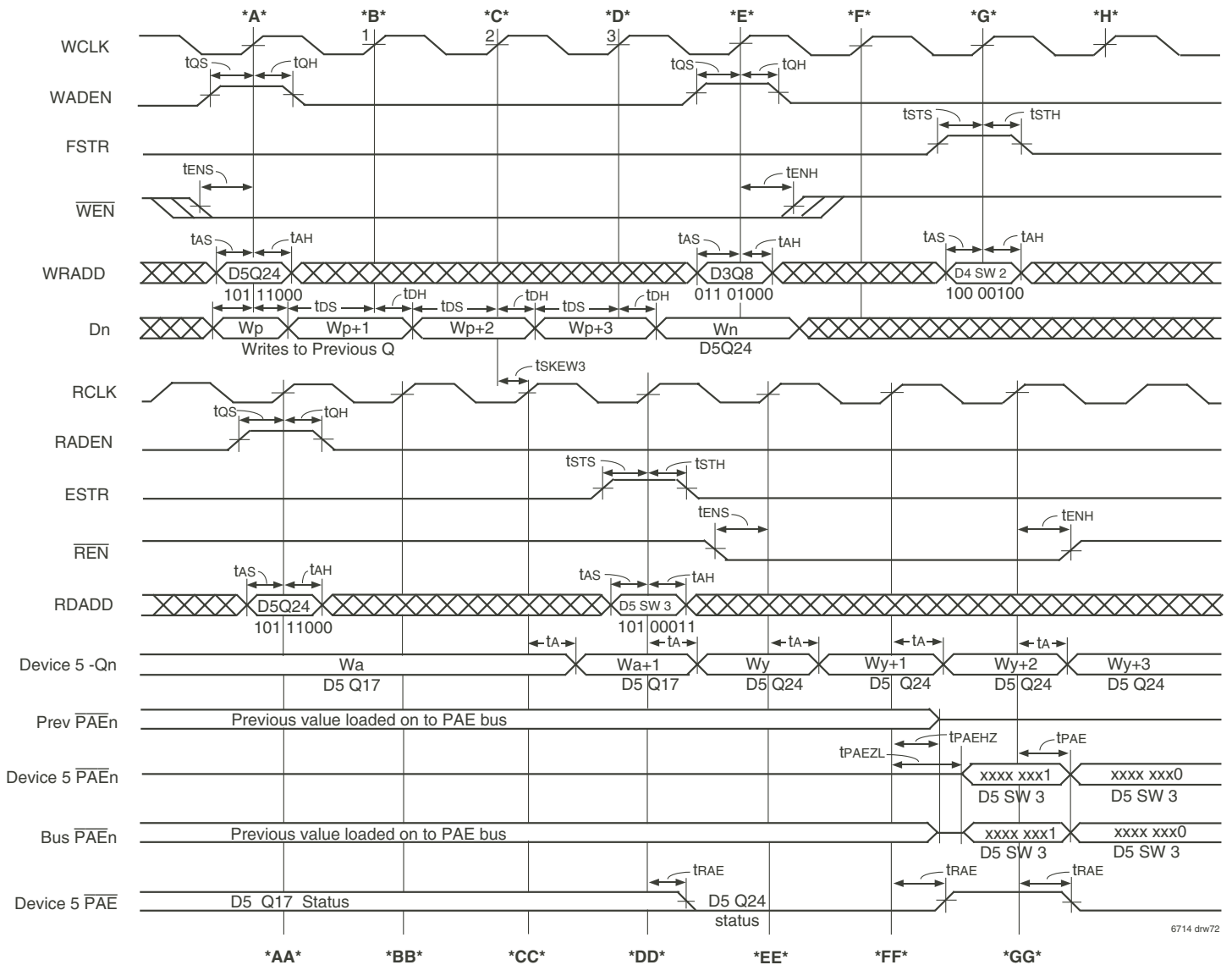

- Cycle:**
- *A*** Queue 24 of Device 5 is selected for write operations. Word W_p is written into the previously selected queue.
 - *AA*** Queue 24 of Device 5 is selected for read operations. A status word from another device has control of the \overline{PAEn} bus. The discrete \overline{PAE} output of device 5 is currently in High-Impedance and the \overline{PAE} active flag is controlled by the previously selected device.
 - *B*** Word W_{p+1} is written into the previously selected queue.
 - *BB*** Current Word is kept on the output bus since \overline{REN} is HIGH.
 - *C*** Word W_{p+2} is written into the previously selected queue.
 - *CC*** Word W_{a+1} of D5 Q17 is read due to FWFT.
 - *D*** Word, W_n is written into the newly selected queue, Q24 of D5. This write will cause the \overline{PAE} flag on the read port to go from LOW to HIGH (not almost empty) after time, $t_{SKEW3} + RCLK + t_{RAE}$ (if t_{SKEW3} is violated one extra RCLK cycle will be added).
 - *DD*** Word, W_y from the newly selected queue, Q24 will be read out due to FWFT operation. Status word 4 of Device 5 is selected on the \overline{PAEn} bus. Q24 of device 5 will therefore have its \overline{PAE} status output on $\overline{PAE}[0]$. There is a single RCLK cycle latency before the \overline{PAEn} bus changes to the new selection.
 - *E*** Queue 8 of Device 3 is selected for write operations. Word W_{n+1} is written into Q24 of D5.
 - *EE*** Word, W_{y+1} is read from Q24 of D5.
 - *F*** No writes occur.
 - *FF*** Word, W_{y+2} is read from Q24 of D5. The \overline{PAEn} bus changes control to D5, the \overline{PAEn} outputs of D5 go to Low-Impedance and status word 4 is placed onto the outputs. The device of the previously selected status word now places its \overline{PAEn} outputs into High-Impedance to prevent bus contention. The discrete \overline{PAE} flag will go HIGH to show that Q24 of D5 is not almost empty. Q24 of device 5 will have its \overline{PAE} status output on $\overline{PAE}[0]$.
 - *G*** Status word 3 of device 4 is selected on the write port for the \overline{PAFn} bus.
 - *GG*** The \overline{PAEn} bus updates to show that Q24 of D5 is almost empty based on the reading out of word, W_{y+1} . The discrete \overline{PAE} flag goes LOW to show that Q24 of D5 is almost empty based on the reading of W_{y+1} .

Figure 64. \overline{PAEn} - Direct Mode, Flag Operation

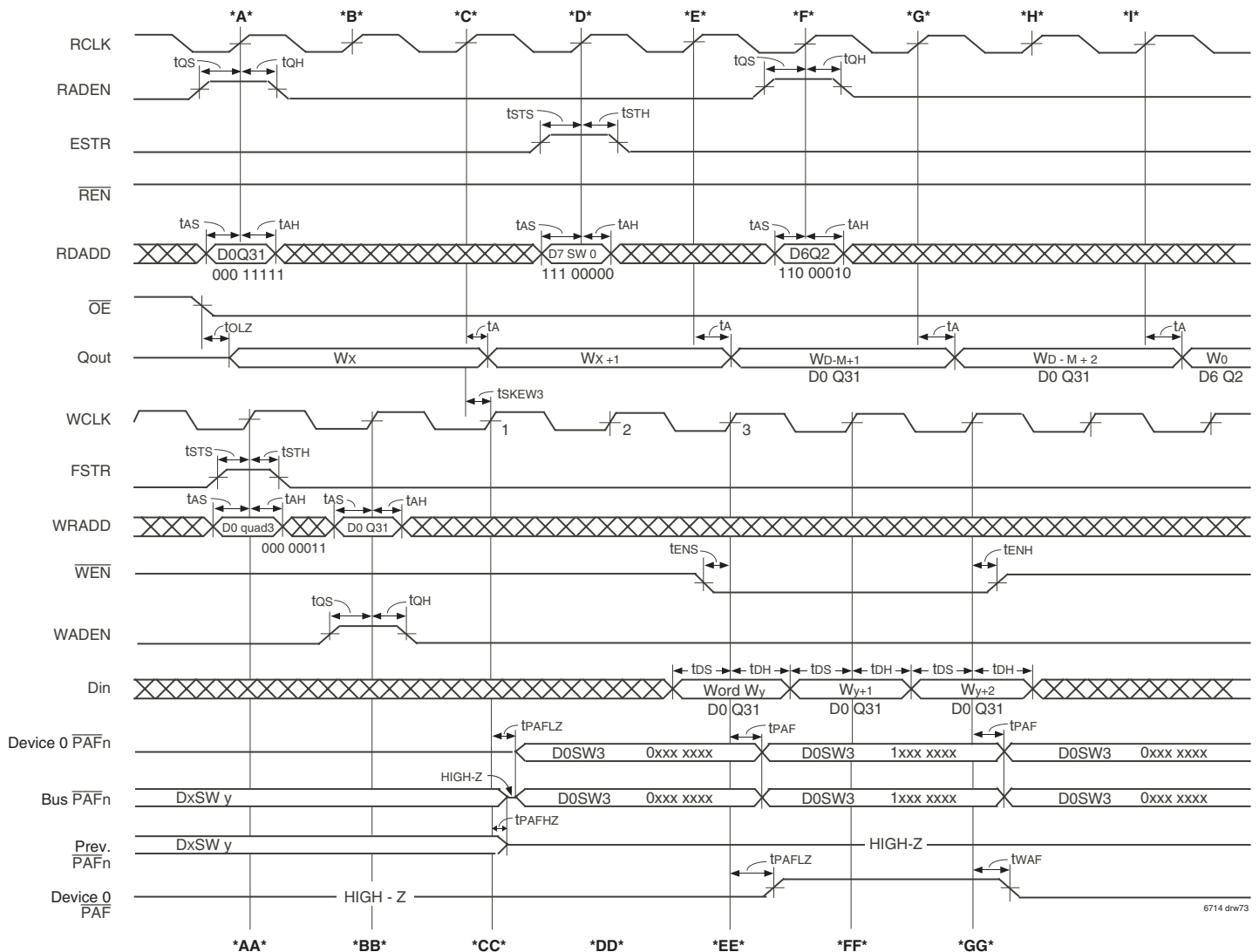

- Cycle:**
- *A*** Queue 31 of device 0 is selected for read operations.
The last word in the output register is available on Qout. \overline{OE} was previously taken LOW so the output bus is in Low-Impedance.
 - *AA*** Status word 4 of device 0 is selected for the \overline{PAFn} bus. The bus is currently providing status of a previously selected status word, Quad Y of device X.
 - *B*** No read operation.
 - *BB*** Queue 31 of device 0 is selected on the write port.
 - *C*** Word, W_{x+1} is read out from the previous queue due to the FWFT effect.
 - *CC*** \overline{PAFn} continues to show status of Quad4 D0.
The \overline{PAFn} bus is updated with the status word selected on the previous cycle, D0 Quad 4. $\overline{PAF}[7]$ is LOW showing the status of queue 31.
The \overline{PAFn} outputs of the device previously selected on the \overline{PAFn} bus go to High-Impedance.
 - *D*** A new status word, Quad 0 of Device 7 is selected for the \overline{PAFn} bus.
Word, W_{d-m+1} is read from Q31 D0 due to the FWFT operation. This read is at the \overline{PAFn} boundary of queue D0 Q31. This read will cause the $\overline{PAF}[7]$ output to go from LOW to HIGH (almost full to not almost full), after a delay $t_{SKEW3} + WCLK + t_{PAF}$. If t_{SKEW3} is violated add an extra WCLK cycle.
 - *DD*** No write operation.
 - *E*** No read operations occur, \overline{REN} is HIGH.
 - *EE*** $\overline{PAF}[7]$ goes HIGH to show that D0 Q31 is not almost empty due to the read on cycle *C*.
The active queue PAF flag of device 0 goes from High-Impedance to Low-Impedance.
Word, W_y is written into D0 Q31.
 - *F*** Queue 2 of Device 6 is selected for read operations.
 - *FF*** Word, W_{y+1} is written into D0 Q31.
 - *G*** Word, W_{d-m+2} is read out due to FWFT operation.
 - *GG*** $\overline{PAF}[7]$ and the discrete PAF flag go LOW to show the write on cycle *DD* causes Q31 of D0 to again go almost full.
Word, W_{y+2} is written into D0 Q31.
 - *H*** No read operation.
 - *I*** Word, W_0 is read from Q0 of D6, selected on cycle *F*, due to FWFT.

Figure 65. \overline{PAFn} - Direct Mode, Flag Operation

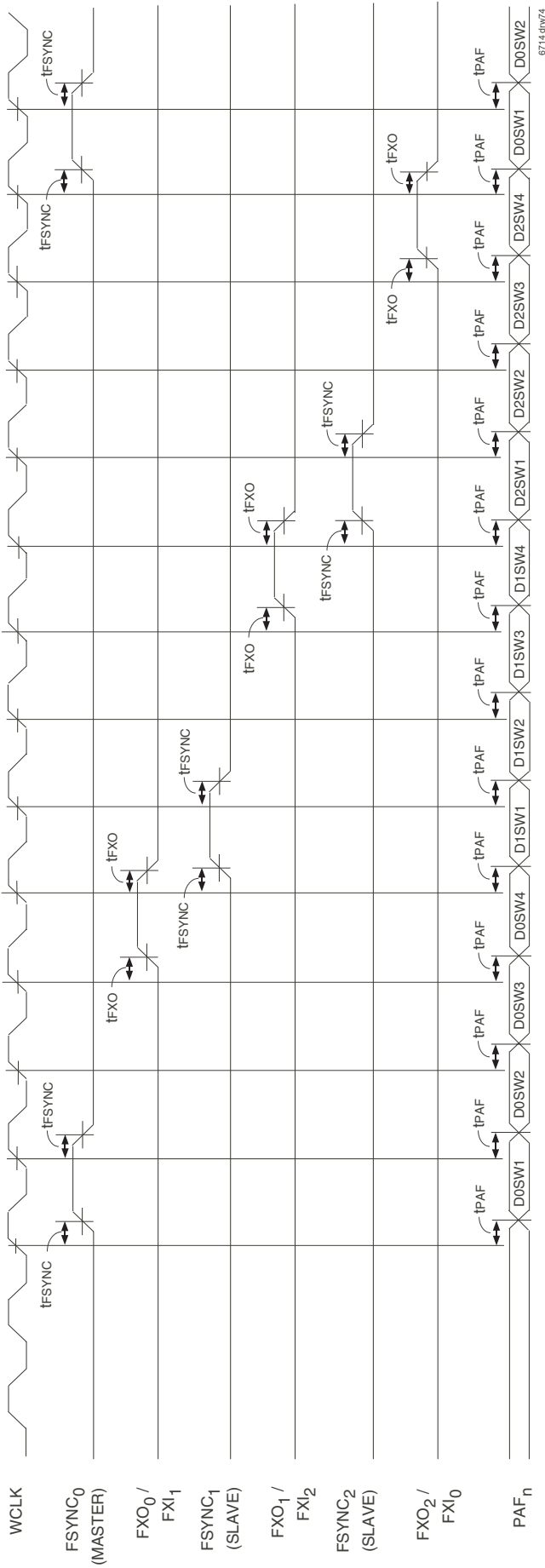

NOTE:

1. This diagram is based on 3 devices connected in expansion configuration.

Figure 66. PAFn Bus - Polled Mode

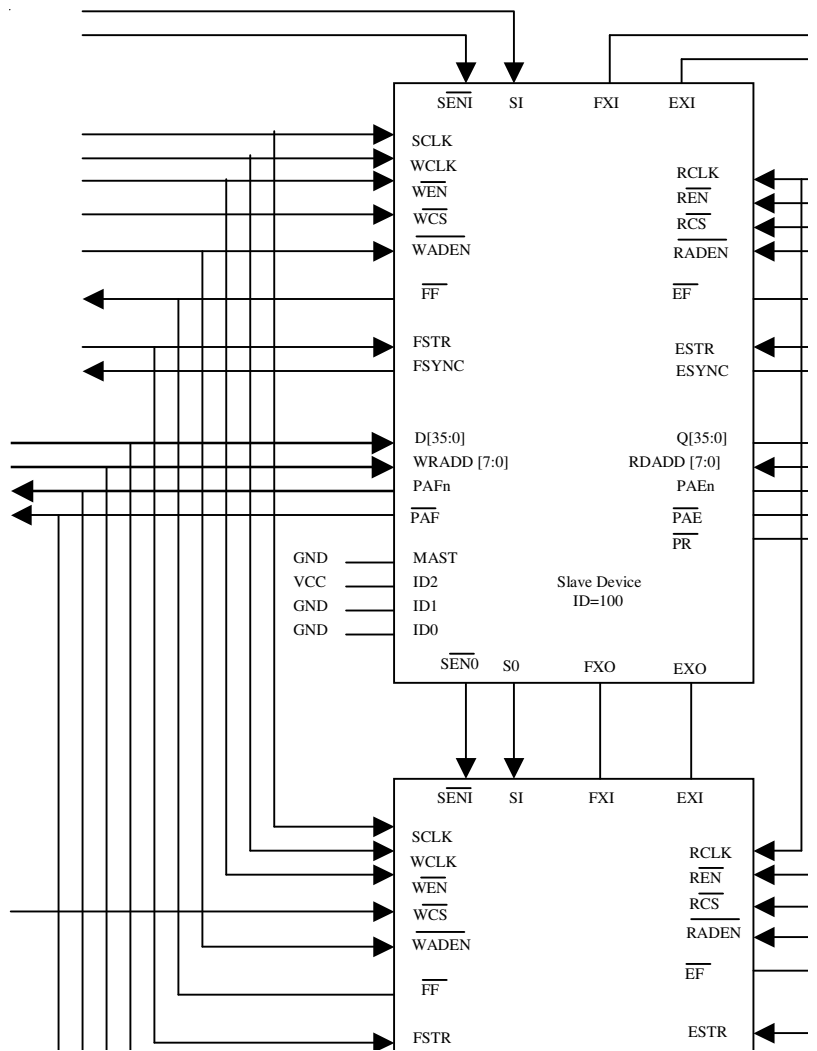

NOTE:
 1. ID2 MUST be unique between the devices.

Figure 67. Connecting two 4M MQ 128Q devices in Expansion Mode

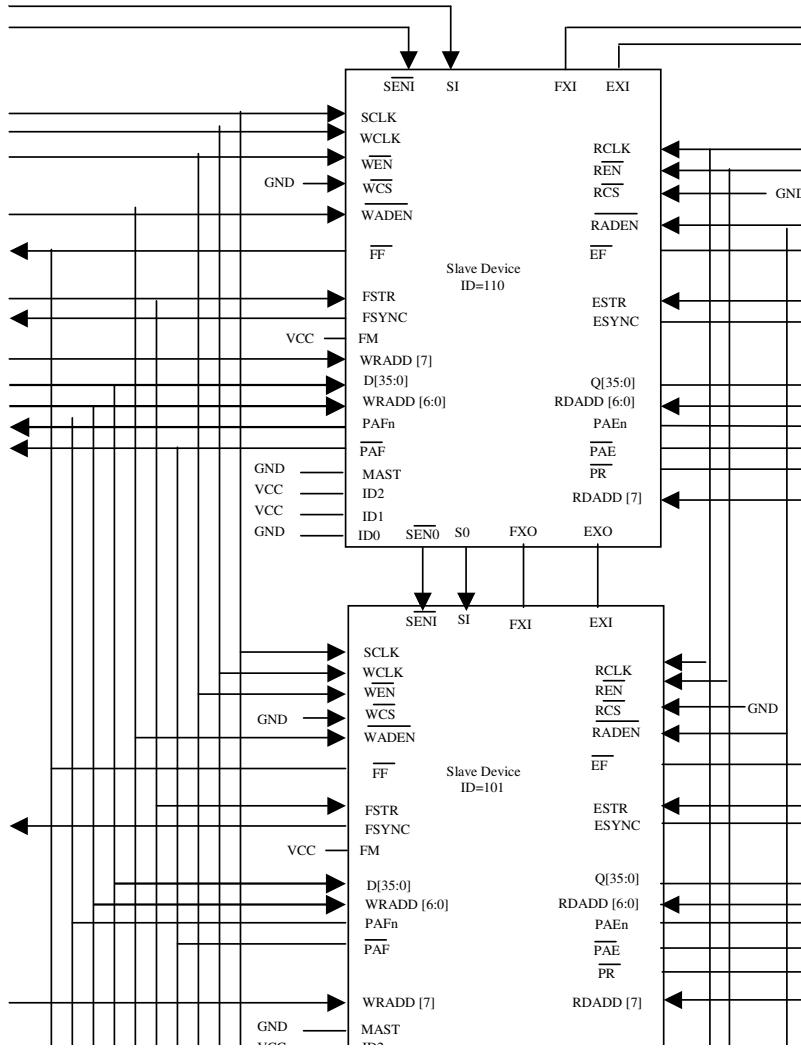

Figure 68. Connecting Three or more 4M MQ 128Q in Expansion mode using WRADD bit 7 / RDADD bit 7

JTAG INTERFACE

Five additional pins (TDI, TDO, TMS, TCK and $\overline{\text{TRST}}$) are provided to support the JTAG boundary scan interface. The IDT72P51749/72P51759/72P51769 incorporates the necessary tap controller and modified pad cells to implement the JTAG facility.

Note that IDT provides appropriate Boundary Scan Description Language program files for these devices.

The Standard JTAG interface consists of four basic elements:

- Test Access Port (TAP)
- TAP controller
- Instruction Register (IR)
- Data Register Port (DR)

The following sections provide a brief description of each element. For a complete description refer to the IEEE Standard Test Access Port Specification (IEEE Std. 1149.1-1990).

The Figure below shows the standard Boundary-Scan Architecture

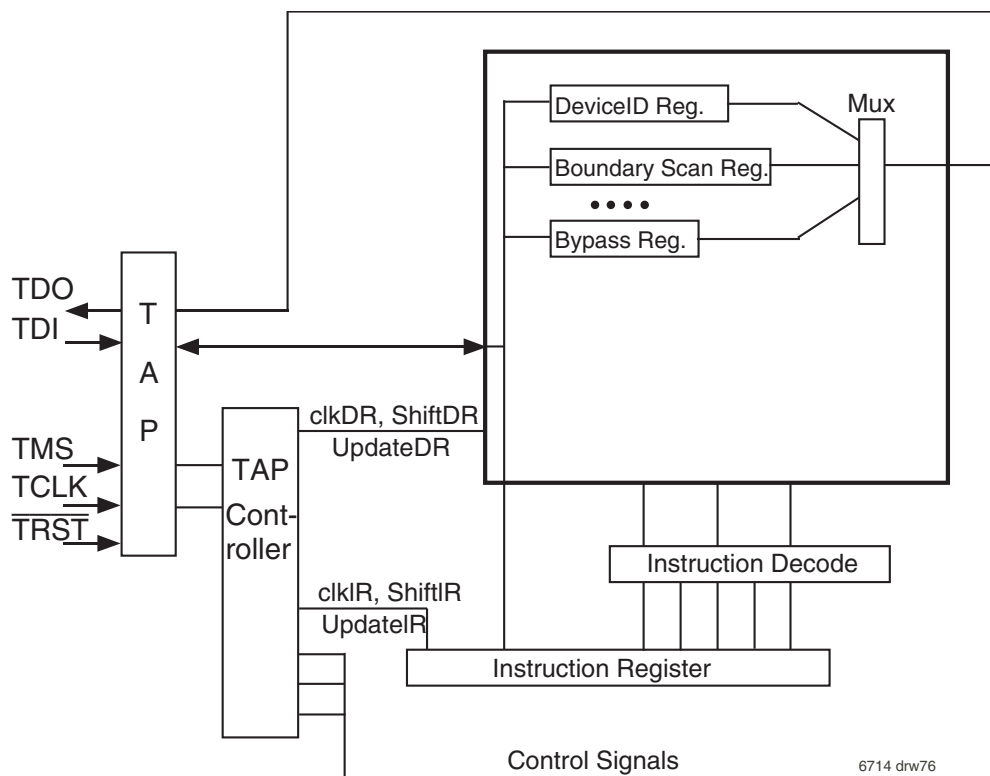

Figure 69. Boundary Scan Architecture

TEST ACCESS PORT (TAP)

The Tap interface is a general-purpose port that provides access to the internal of the processor. It consists of four input ports (TCLK, TMS, TDI, $\overline{\text{TRST}}$) and one output port (TDO).

THE TAP CONTROLLER

The Tap controller is a synchronous finite state machine that responds to TMS and TCLK signals to generate clock and control signals to the Instruction and Data Registers for capture and update of data.

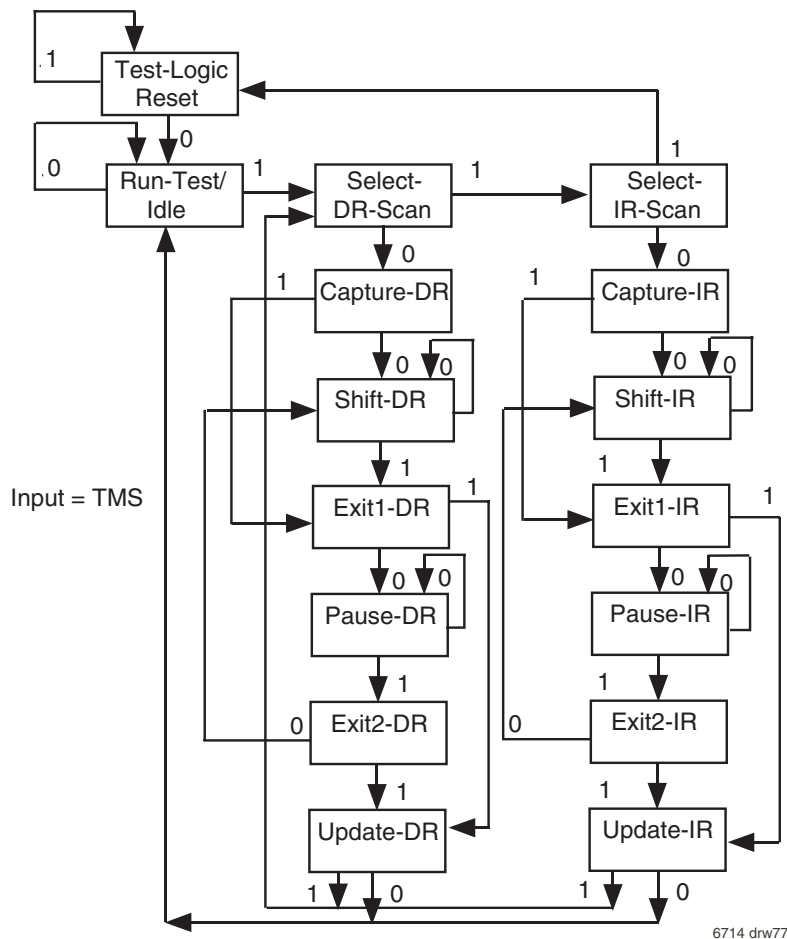

NOTES:

1. Five consecutive TCK cycles with TMS = 1 will reset the TAP.
2. TAP controller does not automatically reset upon power-up. The user must provide a reset to the TAP controller (either by $\overline{\text{TRST}}$ or TMS).
3. TAP controller must be reset before normal Queue operations can begin.

Figure 70. TAP Controller State Diagram

Refer to the IEEE Standard Test Access Port Specification (IEEE Std. 1149.1) for the full state diagram.

All state transitions within the TAP controller occur at the rising edge of the TCLK pulse. The TMS signal level (0 or 1) determines the state progression that occurs on each TCLK rising edge. The TAP controller takes precedence over the Queue and must be reset after power up of the device. See $\overline{\text{TRST}}$ description for more details on TAP controller reset.

Test-Logic-Reset All test logic is disabled in this controller state enabling the normal operation of the IC. The TAP controller state machine is designed in such a way that, no matter what the initial state of the controller is, the Test-Logic-Reset state can be entered by holding TMS at high and pulsing TCK five times. This is the reason why the Test Reset ($\overline{\text{TRST}}$) pin is optional.

Run-Test-Idle In this controller state, the test logic in the IC is active only if certain instructions are present. For example, if an instruction activates the self test, then it will be executed when the controller enters this state. The test logic in the IC is idles otherwise.

Select-DR-Scan This is a controller state where the decision to enter the Data Path or the Select-IR-Scan state is made.

Select-IR-Scan This is a controller state where the decision to enter the Instruction Path is made. The Controller can return to the Test-Logic-Reset state otherwise.

Capture-IR In this controller state, the shift register bank in the Instruction Register parallel loads a pattern of fixed values on the rising edge of TCK. The last two significant bits are always required to be "01".

Shift-IR In this controller state, the instruction register gets connected between TDI and TDO, and the captured pattern gets shifted on each rising edge of TCK. The instruction available on the TDI pin is also shifted in to the instruction register.

Exit1-IR This is a controller state where a decision to enter either the Pause-IR state or Update-IR state is made.

Pause-IR This state is provided in order to allow the shifting of instruction register to be temporarily halted.

Exit2-DR This is a controller state where a decision to enter either the Shift-IR state or Update-IR state is made.

Update-IR In this controller state, the instruction in the instruction register is latched in to the latch bank of the Instruction Register on every falling edge of TCK. This instruction also becomes the current instruction once it is latched.

Capture-DR In this controller state, the data is parallel loaded in to the data registers selected by the current instruction on the rising edge of TCK.

Shift-DR, Exit1-DR, Pause-DR, Exit2-DR and Update-DR These controller states are similar to the Shift-IR, Exit1-IR, Pause-IR, Exit2-IR and Update-IR states in the Instruction path.

THE INSTRUCTION REGISTER

The Instruction register allows an instruction to be shifted in serially into the processor at the rising edge of TCLK.

The Instruction is used to select the test to be performed, or the test data register to be accessed, or both. The instruction shifted into the register is latched at the completion of the shifting process when the TAP controller is at Update-IR state.

The instruction register must contain 4 bit instruction register-based cells which can hold instruction data. These mandatory cells are located nearest the serial outputs they are the least significant bits.

TEST DATA REGISTER

The Test Data register contains three test data registers: the Bypass, the Boundary Scan register and Device ID register.

These registers are connected in parallel between a common serial input and a common serial data output.

The following sections provide a brief description of each element. For a complete description, refer to the IEEE Standard Test Access Port Specification (IEEE Std. 1149.1-1990).

TEST BYPASS REGISTER

The register is used to allow test data to flow through the device from TDI to TDO. It contains a single stage shift register for a minimum length in serial path. When the bypass register is selected by an instruction, the shift register stage is set to a logic zero on the rising edge of TCLK when the TAP controller is in the Capture-DR state.

The operation of the bypass register should not have any effect on the operation of the device in response to the BYPASS instruction.

THE BOUNDARY-SCAN REGISTER

The Boundary Scan Register allows serial data TDI be loaded in to or read out of the processor input/output ports. The Boundary Scan Register is a part of the IEEE 1149.1-1990 Standard JTAG Implementation.

THE DEVICE IDENTIFICATION REGISTER

The Device Identification Register is a Read Only 32-bit register used to specify the manufacturer, part number and version of the processor to be determined through the TAP in response to the IDCODE instruction.

IDT JEDEC ID number is 0xB3. This translates to 0x33 when the parity is dropped in the 11-bit Manufacturer ID field.

For the IDT72P51749/72P51759/72P51769, the Part Number field contains the following values:

Device	Part# Field (HEX)
IDT72P51749	047F
IDT72P51759	0480
IDT72P51769	0481

31(MSb)	28 27	12 11	1 0(LSB)
Version (4 bits)	Part Number (16-bit)	Manufacturer ID (11-bit)	1
0X0		0X33	

JTAG DEVICE IDENTIFICATION REGISTER

JTAG INSTRUCTION REGISTER

The Instruction register allows instruction to be serially input into the device when the TAP controller is in the Shift-IR state. The instruction is decoded to perform the following:

- Select test data registers that may operate while the instruction is current. The other test data registers should not interfere with chip operation and the selected data register.
- Define the serial test data register path that is used to shift data between TDI and TDO during data register scanning.

The Instruction Register is a 4 bit field (i.e. IR3, IR2, IR1, IR0) to decode 16 different possible instructions. Instructions are decoded as follows.

Hex Value	Instruction	Function
00	EXTEST	Select Boundary Scan Register
01	SAMPLE/PRELOAD	Select Boundary Scan Register
02	IDCODE	Select Chip Identification data register
03	HIGH-IMPEDANCE	JTAG
0F	BYPASS	Select Bypass Register

JTAG INSTRUCTION REGISTER DECODING

The following sections provide a brief description of each instruction. For a complete description refer to the IEEE Standard Test Access Port Specification (IEEE Std. 1149.1-1990).

EXTEST

The required EXTEST instruction places the IC into an external boundary-test mode and selects the boundary-scan register to be connected between TDI and TDO. During this instruction, the boundary-scan register is accessed to drive test data off-chip via the boundary outputs and receive test data off-chip via the boundary inputs. As such, the EXTEST instruction is the workhorse of IEEE Std 1149.1, providing for probe-less testing of solder-joint opens/shorts and of logic cluster function.

IDCODE

The optional IDCODE instruction allows the IC to remain in its functional mode and selects the optional device identification register to be connected between TDI and TDO. The device identification register is a 32-bit shift register containing information regarding the IC manufacturer, device type, and version code. Accessing the device identification register does not interfere with the operation of the IC. Also, access to the device identification register should be immediately available, via a TAP data-scan operation, after power-up of the IC or after the TAP has been reset using the optional TRST pin or by otherwise moving to the Test-Logic-Reset state.

SAMPLE/PRELOAD

The required SAMPLE/PRELOAD instruction allows the IC to remain in a normal functional mode and selects the boundary-scan register to be connected between TDI and TDO. During this instruction, the boundary-scan register can be accessed via a data scan operation, to take a sample of the functional data entering and leaving the IC. This instruction is also used to preload test data into the boundary-scan register before loading an EXTEST instruction.

HIGH-IMPEDANCE

The optional High-Impedance instruction sets all outputs (including two-state as well as three-state types) of an IC to a disabled (high-impedance) state and selects the one-bit bypass register to be connected between TDI and TDO. During this instruction, data can be shifted through the bypass register from TDI to TDO without affecting the condition of the IC outputs.

BYPASS

The required BYPASS instruction allows the IC to remain in a normal functional mode and selects the one-bit bypass register to be connected between TDI and TDO. The BYPASS instruction allows serial data to be transferred through the IC from TDI to TDO without affecting the operation of the IC.

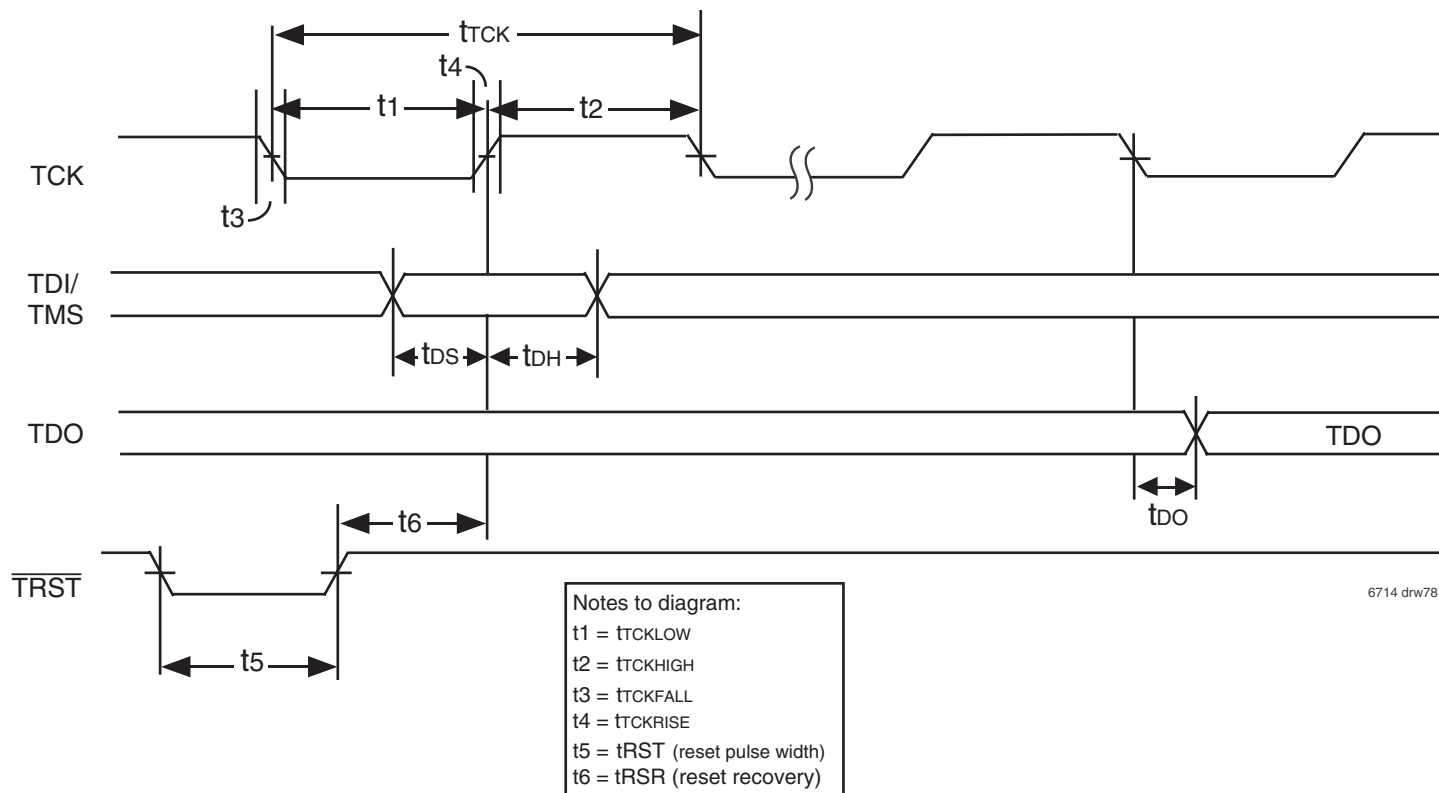

Figure 71. Standard JTAG Timing

SYSTEM INTERFACE PARAMETERS

Parameter	Symbol	Test Conditions	IDT72P51749 IDT72P51759 IDT72P51769		
			Min.	Max.	Units
Data Output	tDO ⁽¹⁾		-	20	ns
Data Output Hold	tDOH ⁽¹⁾		0	-	ns
Data Input	tDS	trise=3ns	10	-	ns
	tDH	tfall=3ns	10	-	ns

NOTE:
1. 50pf loading on external output signals.

JTAG

AC ELECTRICAL CHARACTERISTICS

(VDD = 2.5V ± 5%; Tcase = 0°C to +85°C)

Parameter	Symbol	Test Conditions			
			Min.	Max.	Units
JTAG Clock Input Period	tTCK	-	100	-	ns
JTAG Clock HIGH	tTCKHIGH	-	40	-	ns
JTAG Clock Low	tTCKLOW	-	40	-	ns
JTAG Clock Rise Time	tTCKRISE	-	-	5 ⁽¹⁾	ns
JTAG Clock Fall Time	tTCKFALL	-	-	5 ⁽¹⁾	ns
JTAG Reset	tRST	-	50	-	ns
JTAG Reset Recovery	tRSR	-	50	-	ns

NOTE:
1. Guaranteed by design.

ORDERING INFORMATION

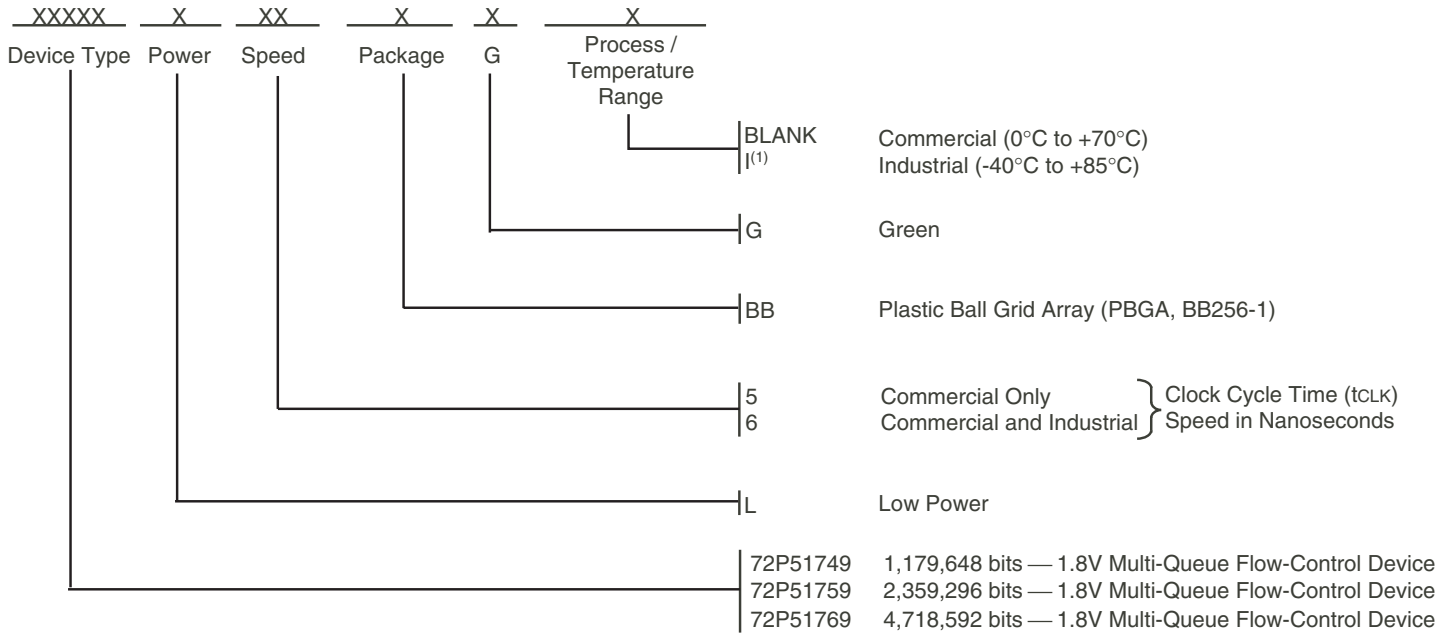

6714 drw79

NOTES:

1. Industrial temperature range product for the 6ns is available as a standard device. All other speed grades available by special order.
2. Green parts are available. For specific speeds contact your local sales office.

DATASHEET DOCUMENT HISTORY

02/04/2005	pg. 11.
08/01/2005	pgs. 1, 3, 4, 7, 9, 11, 13, 15, 17, 18, 20, 21, 25-28, 30-32, 45, 54-56, 58-66, 73, 74, 79, 80 and 86.
02/10/2009	pg. 86.



CORPORATE HEADQUARTERS
 6024 Silver Creek Valley Road
 San Jose, CA 95138

for SALES:
 800-345-7015 or 408-284-8200
 fax: 408-284-2775
 www.idt.com

for Tech Support:
 408-360-1533
 email: Flow-Controlhelp@idt.com