

Analog signal I / O interface for portable audio applications

BH7760KV

The BH7760KV contains the complete audio I / O analog block on a single-chip IC. Therefore, all necessary functions for a DVC audio analog I / O interface are provided on one chip.

●Applications

Portable audio applications

●Features

- 1) Contains the input amplifier, wind noise deletion filter, ALC, 30kHz LPF, line amplifier, stereo headphone amplifier, and BTL monaural speaker amplifier required to configure a analog signal I / O interface (audio I / O) all on one chip.
- 2) With the internal 3-line serial control decoder circuit, serial control enables the setting of the various modes for the IC.

●Absolute maximum ratings (Ta = 25°C)

Parameter	Symbol	Limits	Unit
Applied voltage	Vcc	+ 7.0	V
Power dissipation	Pd	900*	mW
Operating temperature	Topr	- 10 ~ + 70	°C
Storage temperature	Tstg	- 55 ~ + 125	°C

* Reduced by 9.0mW for each increase in Ta of 1°C over 25°C with the IC unmounted.

* When mounted on a 70mm × 70mm × 1.6mm glass epoxy board.

●Recommended operating conditions (Ta = 25°C)

Parameter	Symbol	Limits	Unit
Power supply voltage (analog system)	AVcc	+ 4.0 ~ + 6.0	V
Power supply voltage (for SP)	SPVcc	+ 4.0 ~ + 6.0	V
Power supply voltage (digital system)	DVcc	+ 2.7 ~ + 3.3	V

○ Not designed for radiation resistance.

●Block diagram

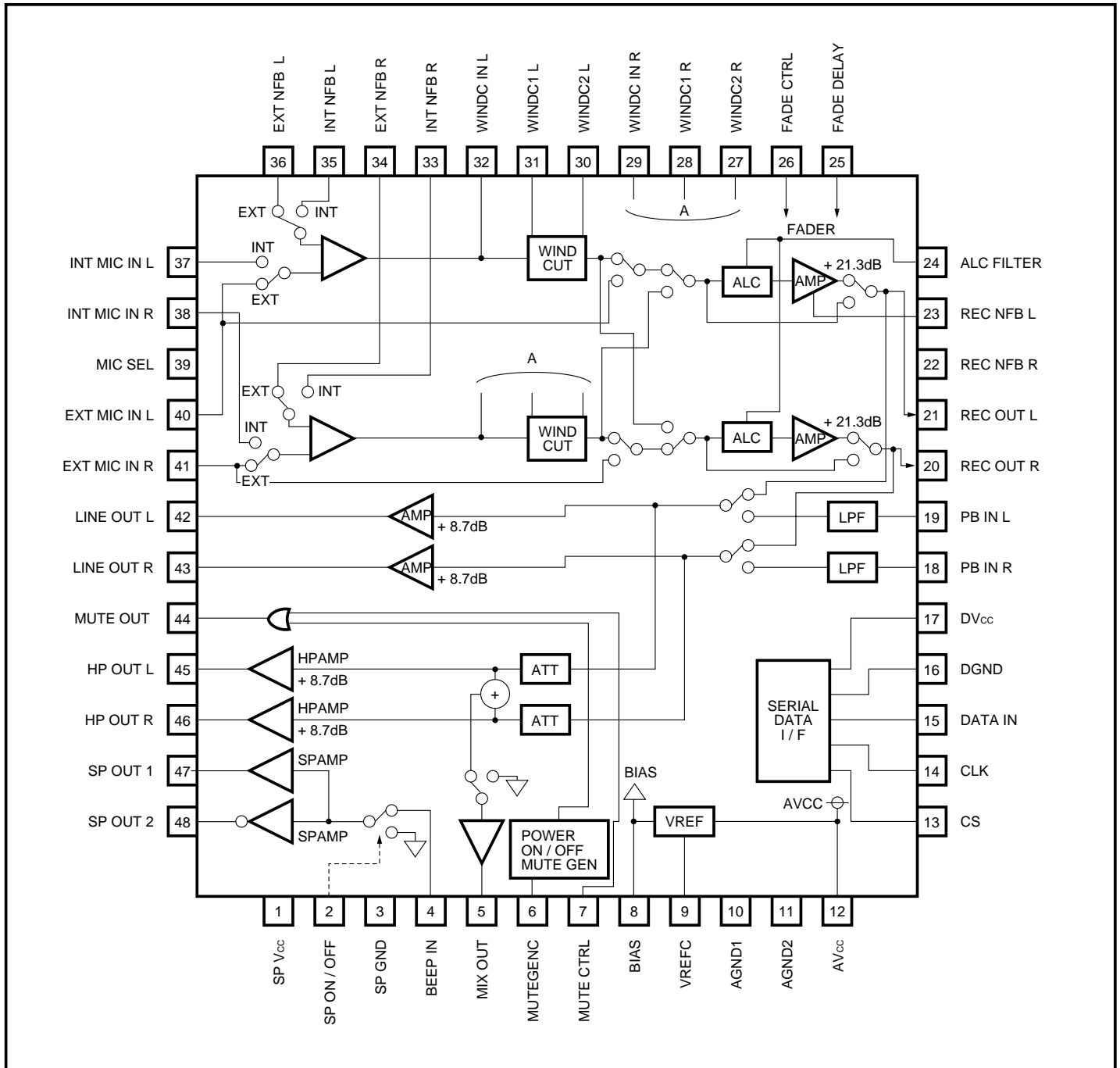

● Pin descriptions

Pin No.	Pin name	Function	Pin voltage	Pin type
1	SP V _{cc}	Speaker V _{cc}	5.0V	—
2	SP ON / OFF	SP ON / OFF control	5.0V	100kΩ PULL UP
3	SP GND	Speaker GND	0.0V	—
4	BEEP IN	Speaker input	2.5V	B (NPN)
5	MIX OUT	HP amplifier L / R mixer output	2.5V	EF (NPN)
6	MUTE GENC	POWER ON MUTE delay	2.5V	EF (NPN)
7	MUTE CTRL	Mute control input	—	10kΩ
8	BIAS	Bias	2.5V	EF (NPN)
9	VREFC	V _{cc} / 2 reference	2.5V	100kΩ
10	AGND1	Analog GND1	0.0V	—
11	AGND2	Analog GND2	0.0V	—
12	AV _{cc}	Analog V _{cc}	5.0V	—
13	CS	Serial control CS input	—	G ~ 10kΩ
14	CLK	Serial control CLK input	—	G ~ 10kΩ
15	DATAIN	Serial control DATE input	—	G ~ 10kΩ
16	DGND	Serial control GND	0.0V	—
17	DV _{cc}	Serial control V _{cc}	3.0V	—
19,18	PBIN L / R	PB input	2.5V	75kΩ
21,20	REC OUT L / R	REC output	2.5V	EF (P-P)
23,22	REC NFB L / R	ALC amplifier feedback	2.5V	B (NPN) ~ 3.9kΩ
24	ALC FILTER	ALC constant setting	0.0V	EF (NPN) ~ 200Ω
25	FADE DELAY	FADE delay	—	B (NPN) ~ 1kΩ
26	FADE CTRL	FADE control input	0.0V	B (NPN) ~ 10kΩ
32,29	WIND CIN L / R	WIND CUT FILTER input	2.5V	EF (P-P)
31,28	WIND C1 L / R	WIND CUT FILTER constant 1	2.5V	EF (NPN) ~ 8.2kΩ
30,27	WIND C2 L / R	WIND CUT FILTER constant 2	2.5V	B (NPN)

Note: EF: Emitter follower, P-P: Push-pull, B: Base, G: gate.

● Pin descriptions

Pin No.	Pin name	Function	Pin voltage	Pin type
36, 34	EXT NFB L / R	MIC amplifier feedback (EXT)	2.5V	B (NPN)
35, 33	INT NFB L / R	MIC amplifier feedback (INT)	2.5V	B (NPN)
37, 38	INT MIC IN L / R	INT MIC input	2.5V	75kΩ
39	MIC SEL	MIC SEL control input	5.0V	200kΩ PULL UP
40, 41	EXT MIC IN L / R	EXT MIC input	2.5V	75kΩ
42, 43	LINE OUT L / R	LINE amplifier output	2.5V	EF (NPN)
44	MUTE OUT	MUTE output	—	C (NPN)
45, 46	HP OUT L / R	HP amplifier output	2.5V	EF (NPN)
47	SP OUT 1	BTL speaker output (forward side)	2.5V	EF (NPN)
48	SP OUT 2	BTL speaker output (reverse side)	2.5V	EF (NPN)

Note: EF: Emitter follower, P-P: Push-pull, B: Base, G: gate.

● Electrical characteristics (unless otherwise noted, $AV_{CC} = SPV_{CC}$, $V_{CC} = 5.0V$, $DV_{CC} = 3.0V$, $T_a = 25^{\circ}C$)

Parameter	Symbol	Min.	Typ.	Max.	Unit	Conditions
[Circuit current]						
Circuit current	I_{CC}	6.0	11.0	20.0	mA	No input
Circuit current power save	I_{CCS}	0.8	1.6	3.2	mA	No input and during power save
[MIC amplifier] INPUT: EXT MIC IN L / R, INT MIC IN L / R OUTPUT: REC OUT L / R						
Output voltage level	V_{OREC}	-21.7	-18.7	-15.7	dBV	$V_{IN} = -70.0\text{dBV}$, with MIC amplifier at 30dB
ALS level	$V_{ORECALC}$	-10.7	-6.7	-2.7	dBV	$V_{IN} = -50.0\text{dBV}$, with MIC amplifier at 30dB
[Line amplifier (during EE)] INPUT: EXT MIC IN L / R, INT MIC IN L / R OUTPUT: LINE OUT L / R						
Output voltage level	$V_{OLINEEE}$	-13.0	-10.0	-7.0	dBV	$V_{IN} = -70.0\text{dBV}$, with MIC amplifier at 30dB
Distortion	THD_{LINEEE}	—	0.50	1.50	%	$V_{IN} = -70.0\text{dBV}$, with MIC amplifier at 30dB* ¹
Output residual noise	$V_{ONLINEEE}$	—	-60.0	-50.0	dBV	With MIC amplifier at 30dB* ²
Crosstalk	CT_{LINEEE}	—	-31.0	-20.0	dBV	$V_{IN} = -60.0\text{dBV}$, with MIC amplifier at 30dB* ¹
Maximum output level	$V_{OMLINEEE}$	-3.0	2.3	—	dBV	THD = 3%, * ¹ , with ALC OFF
[Line amplifier (during PB)] INPUT: PB IN L / R OUTPUT: LINE OUT L / R						
Output voltage level	$V_{OLINEPB}$	-12.0	-10.0	-8.0	dBV	$V_{IN} = -18.7\text{dBV}$
Distortion	THD_{LINEPB}	—	0.017	0.20	%	$V_{IN} = -18.7\text{dBV}$ * ¹
Channel balance	CB_{LINEPB}	-0.5	0.0	+0.5	dB	$V_{OLINE L / R}$ difference
Output residual noise	$V_{ONLINEPB}$	—	-90.0	-73.0	dBV	* ²

*¹ B.W. = 400Hz to 30kHz

*² DIN AUDIO

●Electrical characteristics (unless otherwise noted, AVCC = SP, VCC = 5.0V, DVCC = 3.0V, Ta = 25°C)

Parameter	Symbol	Min.	Typ.	Max.	Unit	Conditions
[HP amplifier] INPUT: PB IN L / R OUTPUT: HP OUT L / R						
Output voltage level	VOHP	- 12.5	- 10.0	- 7.5	dBV	VIN = - 18.7dBV
Distortion	THDHP	—	0.7	2.0	%	VIN = - 18.7dBV*1
Maximum output level	VOMHP	- 3.0	- 1.2	—	dBV	THD = 3%*1
Output residual noise	VONHP	—	- 91.0	- 73.0	dBV	Rg = 1kΩ*2
Crosstalk between channels	CTHP	—	- 87.0	- 70.0	dBV	VIN = - 8.7dBV*2
Muting level	MTHP	—	- 100.0	- 83.0	dBV	VIN = - 8.7dBV, V7 = H*2
[MIX OUT] INPUT: PB IN L / R OUTPUT: MIX OUT						
Output voltage level	VOMIX	- 12.5	- 10.0	- 7.5	dBV	VIN = - 18.7dBV
[SP amplifier] INPUT: BEEP IN OUTPUT: SP OUT 1 / 2 (BML)						
Output voltage level	VOSP	- 4.5	- 1.0	+ 2.5	dBV	VIN = - 10.0dBV
Distortion	THDSP	—	0.8	2.0	%	VIN = - 10.0dBV*1
Maximum output level	VOMSP	+ 3.0	+ 4.8	—	dBV	THD = 10%*1
Output residual noise	VONSP	—	- 95.0	- 80.0	dBV	Rg = 1kΩ*2
SP off level	VOOFFSP	—	- 65.0	- 55.0	dBV	VIN = - 6.0dBV*2
[Control mode hold voltage]						
⟨CS⟩						
Low mode hold voltage	VH14L	0.0	—	0.5	V	—
High mode hold voltage	VH14H	1.8	—	DVCC	V	—
⟨CLK⟩						
Low mode hold voltage	VH15L	0.0	—	0.5	V	—
High mode hold voltage	VH15H	1.8	—	DVCC	V	—
⟨DATA IN⟩						
Low mode hold voltage	VH16L	0.0	—	0.5	V	—
High mode hold voltage	VH16H	1.8	—	DVCC	V	—
⟨SP ON / OFF⟩						
SP off hold voltage	VH3L	0.0	—	0.5	V	—
SP on hold voltage	VH3H	2.0	—	AVCC	V	—
⟨MUTE control⟩						
MUTE hold voltage	VH7L	0.0	—	0.5	V	—
MUTE hold voltage	VH7H	2.0	—	AVCC	V	—
⟨FADE control⟩						
FADE off hold voltage	VH26L	0.0	—	0.5	V	—
FADE on hold voltage	VH26H	2.0	—	AVCC	V	—
⟨MIC SEL⟩						
EXT hold voltage	VH39L	0.0	—	0.5	V	—
INT hold voltage	VH39H	2.0	—	AVCC	V	—

*1 B.W. = 400Hz to 30kHz

*2 DIN AUDIO

● Measurement circuit

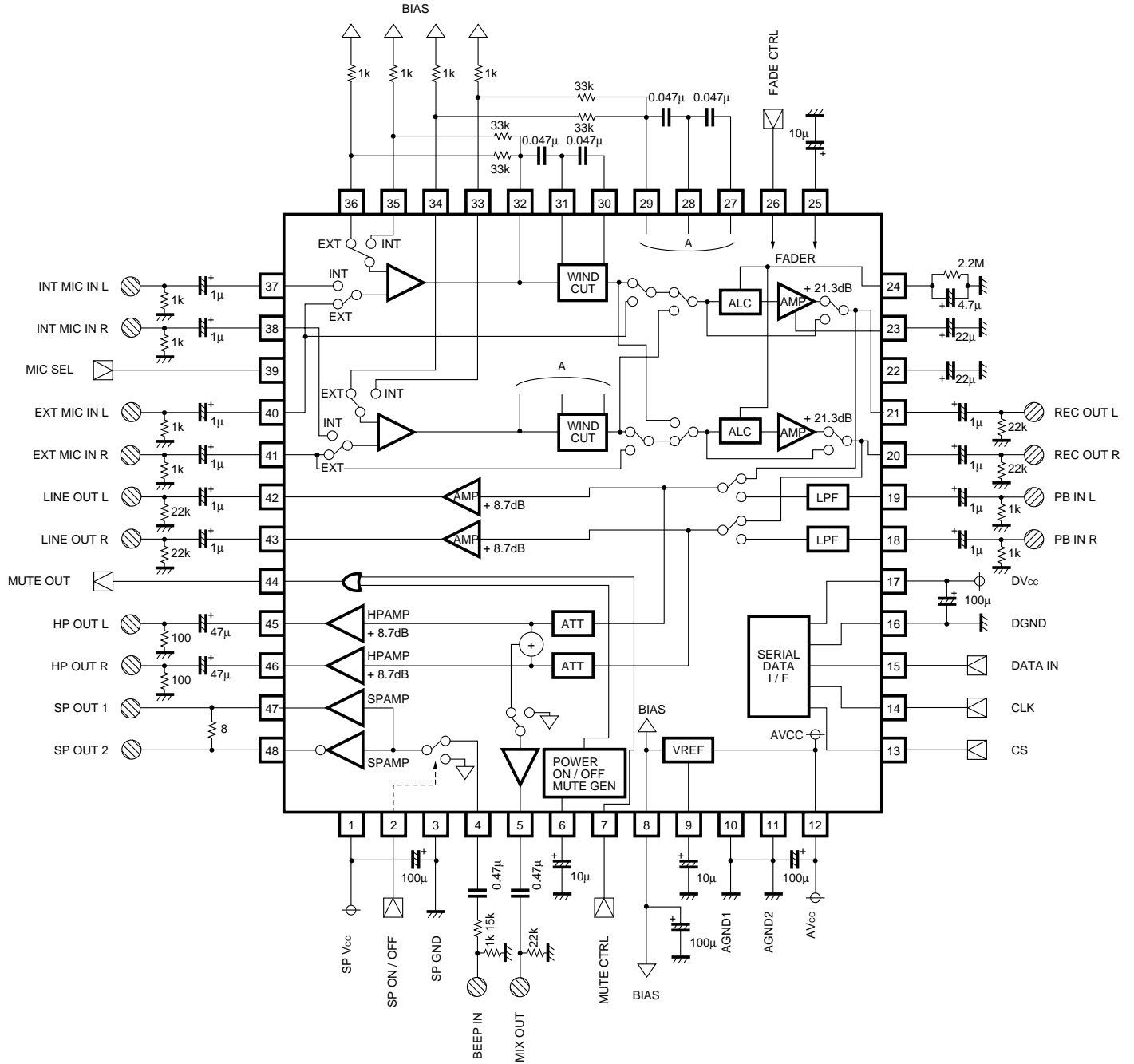

Fig.1

●External dimensions (Units: mm)

