

5-channel BTL driver for CD players

BA6795FP

The BA6795FP is a 5-channel BTL power driver for CD players and has an internal 5V regulator (attached PNP transistor required). The loading and spindle motor output pins are dual-use output pins and are switched between drivers using a control input. In addition, the internal level shifting circuit reduces the number of external components.

●Applications

CD players, CD-ROM drives and other optical disc devices

●Features

- 1) 5-channel BTL driver in a HSOP 28-pin package, ideal for application miniaturization.
- 2) Internal level shifting circuit reduces the number of external components.
- 3) Gain is adjustable with an attached resistor.
- 4) Internal thermal shutdown circuit.
- 5) Internal 5V regulator. (attached PNP transistor required)

●Absolute maximum ratings (Ta = 25°C)

Parameter	Symbol	Limits	Unit
Power supply voltage	V _{cc}	18	V
Power dissipation	P _d	1.7*1	W
Operating temperature	T _{opr}	-35~+85	°C
Storage temperature	T _{stg}	-55~+150	°C

*1 When mounted on a 50 mm×50 mm×1.0 mm paper phenol board
Reduced by 13.6 mW for each increase in Ta of 1°C over 25°C.

●Recommended operating conditions (Ta = 25°C)

Parameter	Symbol	Min.	Typ.	Max.	Unit
Power supply voltage	V _{cc}	4.8	—	12.0	V
		6.0	—	12.0	V*2

*2 Without regulator

● Block diagram

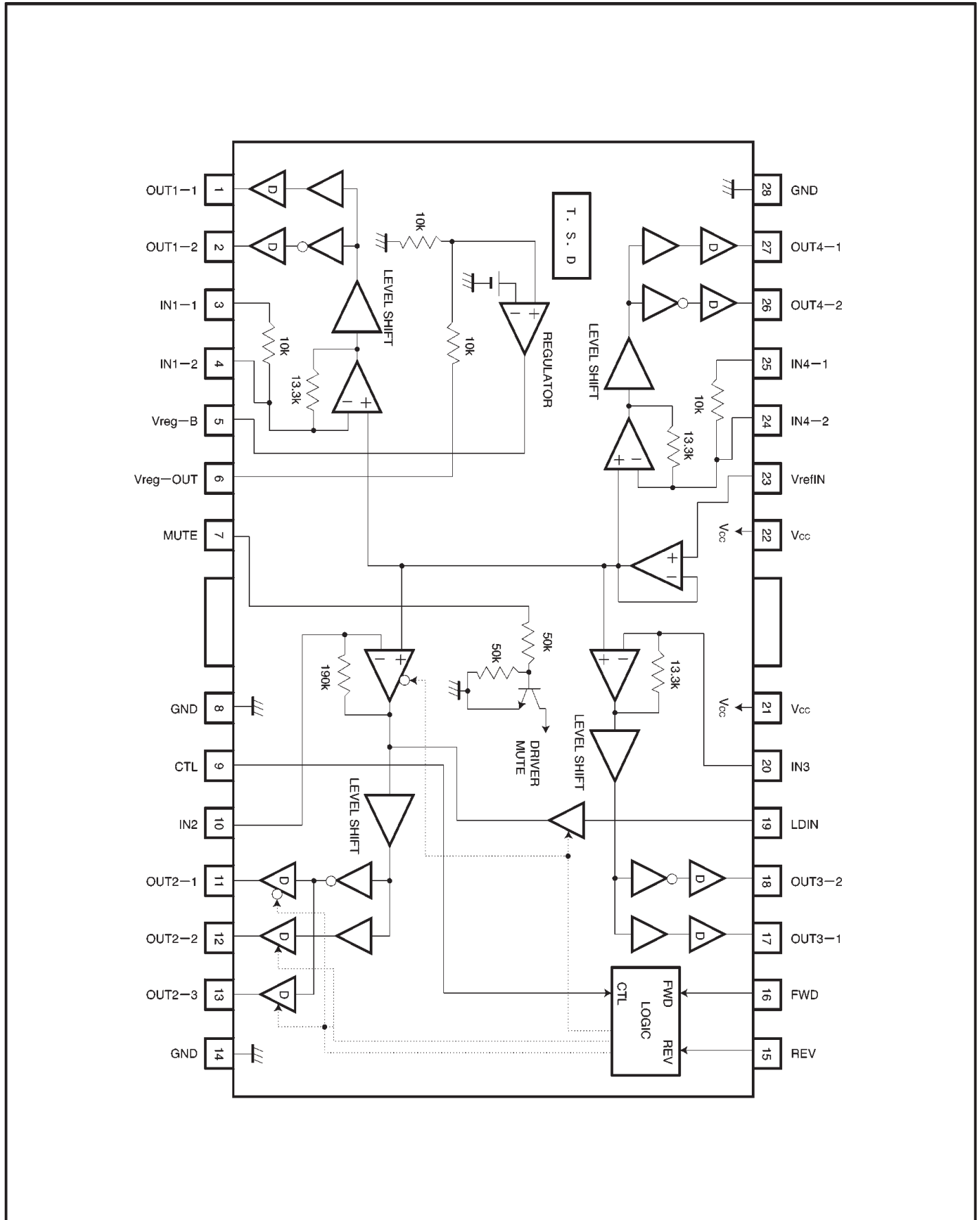

● Pin descriptions

Pin No.	Pin name	Function
1	OUT-1	Channel 1 negative output
2	OUT-2	Channel 1 positive output
3	IN 1-1	Channel 1 input
4	IN 1-2	Channel 1 gain adjustment input
5	Vreg-B	Attached transistor base connection
6	Vreg-OUT	Constant voltage output (attached transistor collector connection)
7	MUTE	Mute-on control
8	GND	Ground
9	CTL	Loading/spindle switching
10	IN 2	Channel 2 gain adjustment input
11	OUT-1	Channel 2 positive output
12	OUT-2	Channel 2 negative output/Loading positive output
13	OUT-3	Loading negative output
14	GND	Substrate ground
15	REV	Loading reverse input
16	FWD	Loading forward input
17	OUT3-1	Channel 3 negative output
18	OUT3-2	Channel 3 positive output
19	LDIN	Loading input
20	IN 3	Channel 3 gain adjustment input
21	V _{CC}	V _{CC}
22	V _{CC}	V _{CC}
23	VrefIN	Bias amplifier input
24	IN 4-2	Channel 4 gain adjustment input
25	IN 4-1	Channel 4 input
26	OUT4-2	Channel 4 positive output
27	OUT4-1	Channel 4 negative output
28	GND	Substrate ground

Note 1: Positive and negative output is relative to the polarity of the input pins.

Note 2: Loading positive output and loading negative output indicate the phase relative to the mode.

●Electrical characteristics (unless otherwise noted, Ta = 25°C, V_{CC} = 8V, f = 1kHz, R_L = 8Ω)

Parameter	Symbol	Min.	Typ.	Max.	Unit	Conditions
Quiescent current dissipation	I _{CC}	7.0	10.0	13.0	mA	No load
Mute-off voltage	V _{MOFF}	2.0	—	—	V	
Mute-on voltage	V _{MON}	—	—	0.5	V	
〈Drivers (other than loading drive)〉						
Output offset voltage 1	V _{OO1}	−40	—	40	mV	Channels 1, 3 and 4, Driver
Output offset voltage 2	V _{OO2}	−60	—	60	V	Channel 2 driver (spindle)
Maximum output voltage 1	V _{OH1}	3.8	4.3	—	V	V _{IN} =8V
Maximum output voltage 2	V _{OH2}	—	−4.3	−3.8	V	V _{IN} =0.7V
Closed loop voltage gain 1	G _{VC1}	5.5	8.0	10.5	dB	V _{IN} = μ0.5V *1
Closed loop voltage gain 2	G _{VC2}	7.5	11.0	14.5	dB	V _{IN} = μ0.5V *2
Ripple rejection	RR	—	60	—	dB	V _{IN} =0.1V _{rms} , 100Hz
Slew rate	SR	—	2.0	—	V/μs	100 Hz square wave, 3V _{P-P} output
〈Loading drivers〉						
Output voltage F	V _{OF}	2.7	3.2	3.7	V	V _{CC} =8V, R _L =45Ω, VLD=3.0V
Output voltage R	V _{OR}	−2.5	−3.0	−3.5	V	
Output voltage range F	V _{OMF}	1.9	2.2	—	V	V _{CC} =8V, R _L =45Ω, VLD=4.5V *3
Output voltage range R	V _{OMR}	—	−2.2	−1.9	V	
Output load variation F1	ΔV _{F1}	—	250	500	mV	V _{CC} =8V, VLD=3.0V I=100→400mA *4
Output load variation R1	ΔV _{R1}	—	250	500	mV	
Output load variation F2	ΔV _{F2}	—	600	850	mV	V _{CC} =5V, VLD=4.5V I=100→400mA *5
Output load variation R2	ΔV _{R2}	—	600	850	mV	
Supply voltage variation F	ΔV _{FL}	−500	—	500	mV	V _{CC} =4.8V→12V, R _L =∞
Supply voltage variation R	ΔV _{RL}	−500	—	500	mV	
Output offset voltage	V _{OOL}	−50	2.0	50	mV	When braking: Output voltage
〈Controllers CTL, FWD and REV〉						
Input high level voltage 1	V _{IH1}	2.0	—	—	V	FWD (pin 16), REV (pin 15) Determined by input pin voltage
Input low level voltage 1	V _{IL1}	—	—	0.5	V	
Input high level voltage 2	V _{IH2}	4.0	—	—	V	CTL (pin 9) Determined by input pin voltage
Input low level voltage 2	V _{IL2}	—	—	0.5	V	
Input high level current	I _{IH}	—	—	500	μA	V _{IN} =5V
Input low level current	I _{IL}	—	—	500	μA	V _{IN} =0V
〈5 V regulator〉						
Output voltage	V _{reg}	4.75	5.00	5.25	V	I _L =100mA
Output load variation	ΔV _{RL}	−50	0	50	mV	I _L =0~200mA
Supply voltage variation	ΔV _{VCC}	−50	0	25	mV	(V _{CC} =6~9V) I _L =100mA

©Not designed for radiation resistance.

*1 Attach a 10 kΩ resistor to the inputs (channel 1, channel 3 and channel 4).

*2 Attach a 100 kΩ resistor to the inputs (channel 2).

*3 V_{omf} and V_{omr} remain roughly the same even when loading input VLD (pin 19) is opened.

*4 ΔV_{r1}, ΔV_{r1} indicate load variation at unclipped, 3.0 V output.

*5 ΔV_{r2}, ΔV_{r2} indicate load variation when output is clipped to generate 4.5 V input at reduced voltage (5 V).

● Measurement circuit

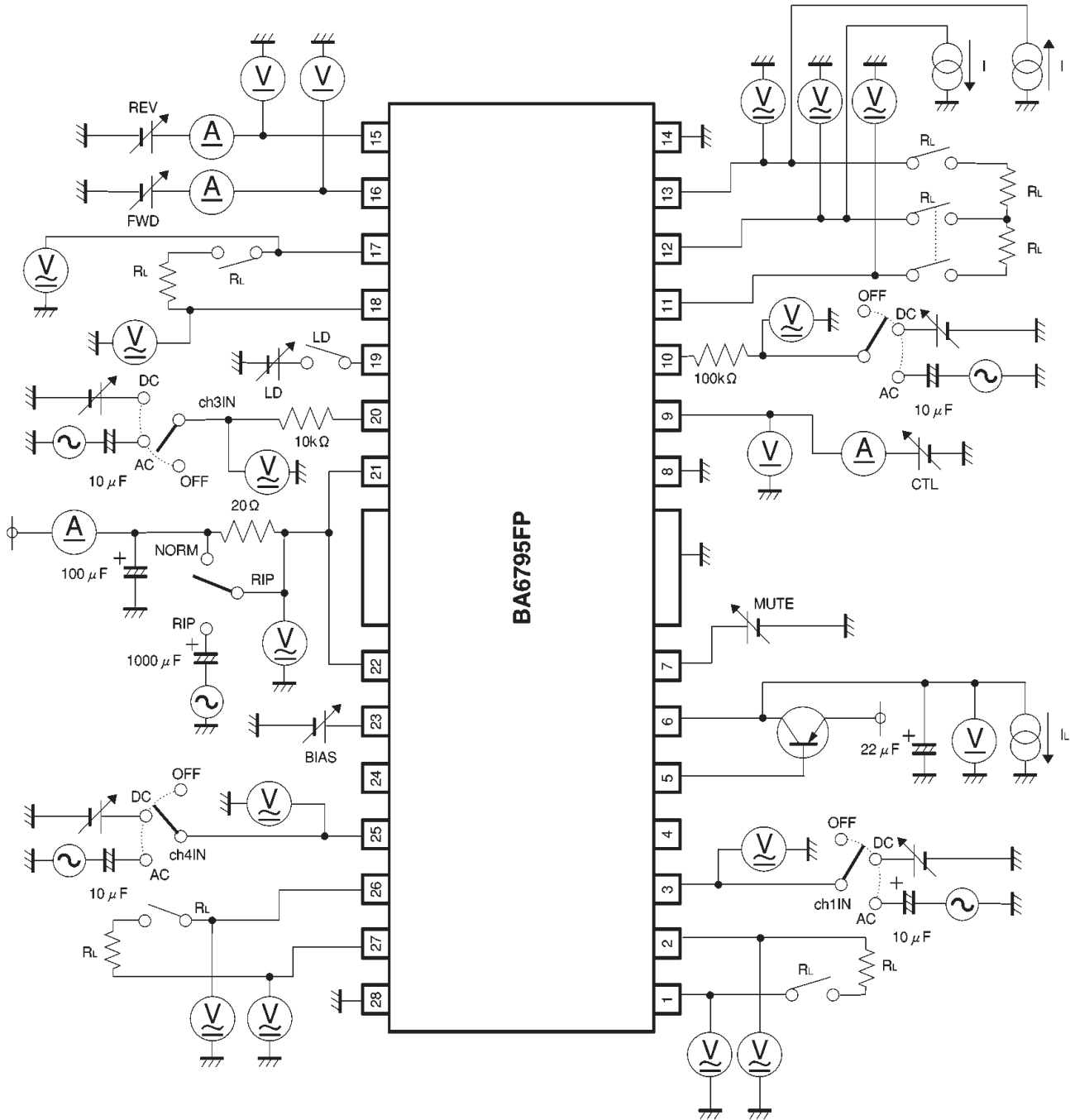

Fig.1

● Measurement circuit switch table

Parameter	Switch								Note
	RL	RL'	LD	RIP	CH1	CH2	CH3	CH4	
Quiescent current dissipation	OFF	OFF	OFF	NORM	OFF	OFF	OFF	OFF	
Mute-off voltage	ON	ON	↓	↓	DC	DC	DC	DC	DC : V _{CC} or GND
Mute-on voltage	ON	ON	↓	↓	DC	DC	DC	DC	DC : V _{CC} or GND
〈Drivers (other than loading driver)〉									
Output offset voltage	ON	ON	OFF	NORM	DC	DC	DC	DC	DC: bias voltage
Maximum output voltage	↓	↓	↓	↓	↓	↓	↓	↓	DC : V _{CC} or 0.7V
Closed loop voltage gain 1	↓	↓	↓	↓	↓	↓	↓	↓	DC: bias ± 0.5 V
Closed loop voltage gain 2	↓	↓	↓	↓	↓	↓	↓	↓	DC: bias ± 0.5 V
Ripple rejection	↓	↓	↓	RIP	↓	↓	↓	↓	DC: bias voltage
Slew rate	↓	↓	↓	NORM	AC	AC	AC	AC	AC: 100 Hz square wave
〈Loading drivers〉									
Output voltage F	ON	ON	ON	NORM	OFF	DC	OFF	OFF	DC: bias voltage
Output voltage R	↓	↓	↓	↓	↓	↓	↓	↓	DC: bias voltage
Output voltage range F	↓	↓	↓	↓	↓	↓	↓	↓	DC: bias voltage
Output voltage range R	↓	↓	↓	↓	↓	↓	↓	↓	DC: bias voltage
Load regulation F	↓	OFF	↓	↓	↓	↓	↓	↓	DC: bias voltage
Load regulation R	↓	↓	↓	↓	↓	↓	↓	↓	DC: bias voltage
Line regulation	↓	↓	↓	↓	↓	↓	↓	↓	DC: bias voltage
Output offset voltage	↓	ON	OFF	↓	↓	↓	↓	↓	DC: bias voltage (brake mode)
〈Controller pins〉									
Input high level voltage 1	ON	ON	OFF	NORM	OFF	DC	OFF	OFF	
Input low level voltage 1	↓	↓	↓	↓	↓	↓	↓	↓	
Input high level voltage 2	↓	↓	↓	↓	↓	↓	↓	↓	
Input low level voltage 2	↓	↓	↓	↓	↓	↓	↓	↓	
Input low level current	OFF	OFF	OFF	↓	↓	OFF	↓	↓	
〈5 V regulator〉									
Output voltage	OFF	OFF	OFF	NORM	OFF	OFF	OFF	OFF	
Load regulation	↓	↓	↓	↓	↓	↓	↓	↓	
Line regulation	↓	↓	↓	↓	↓	↓	↓	↓	

* When measuring drivers (excluding loading driver), CTL voltage should be under 0.5 V.

* I and I_L, used in the test circuit diagram, are the same as the symbols used in electrical characteristics table.

● Circuit operation

(1) Switching between spindle and loading motor driver output modes ($V_{CC} = 8V$)

CTL	FWD	REV	Spindle	Loading	Dimensions	
L	L	L	ON	OFF	Fig. 2	
		H				
	H	L				
		H				
H	L	L	OFF	OFF	High impedance	Fig. 3
		H		ON	Reverse	Fig. 4
	H	L		ON	Forward	Fig. 5
		H		ON	Brake	Fig. 6

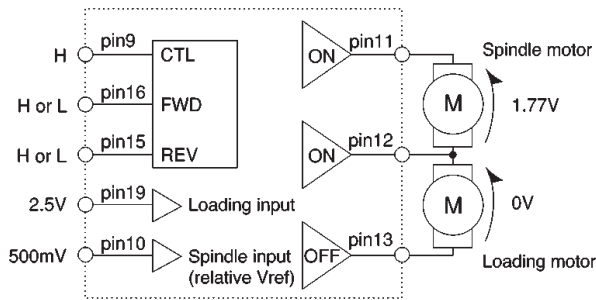

Fig. 2

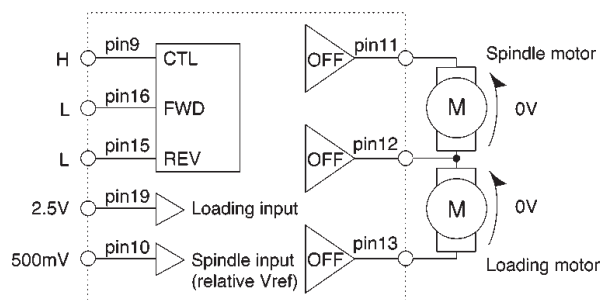

Fig. 3

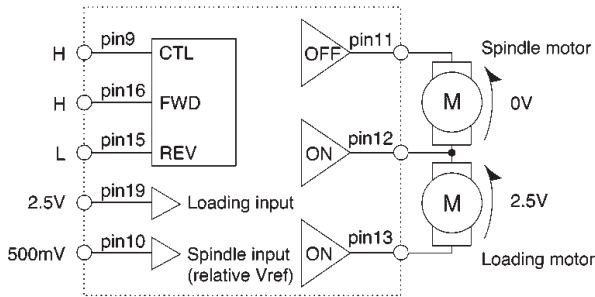

Fig. 4

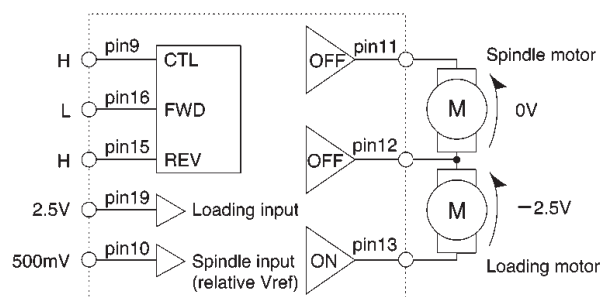

Fig. 5

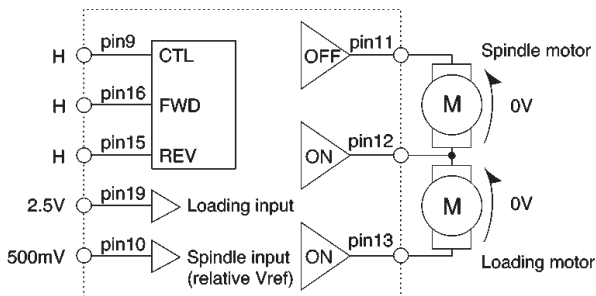
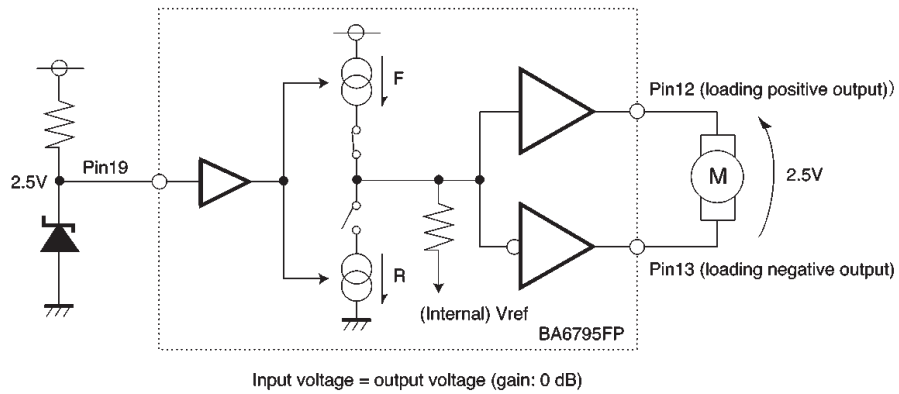

Fig. 6

Note: Gains for spindle driver (channel 2) and loading driver are 11dB and 0dB, respectively.

● Circuit operation

(2) Loading motor driver voltage setting (forward mode)



Note: When the loading input pin (pin 19) is opened, a voltage corresponding to the dynamic range of the power supply being used is output according to the mode.

Fig. 7

●Application example

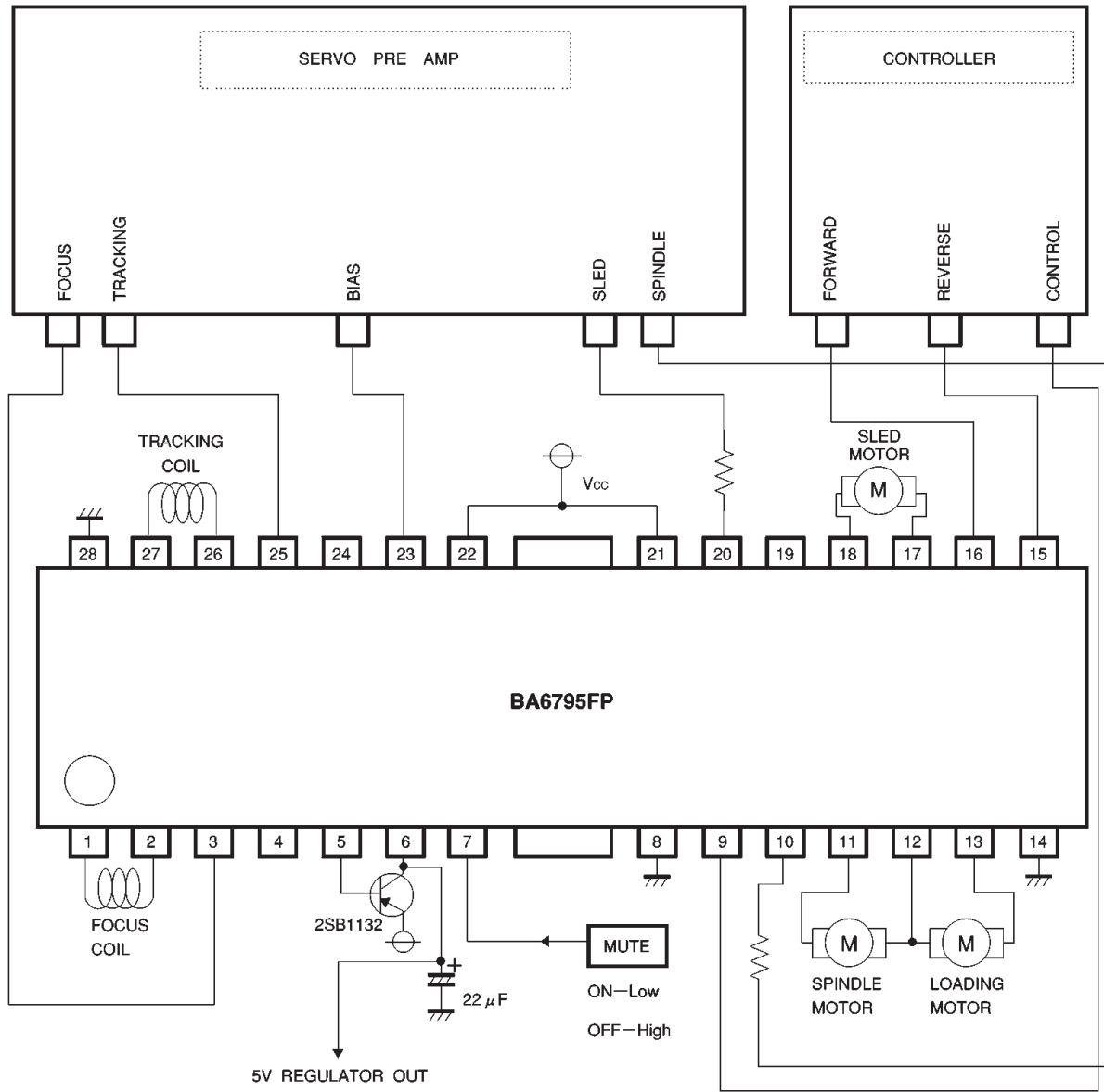

Fig.8

●Operation notes

- (1) The BA6795FP has an internal thermal shutdown circuit. Output current is muted when the chip temperature exceeds 175°C (typically).
- (2) If the mute pin (pin 7) voltage is opened or lowered below 0.5V, the output current will be muted. Pin 7 should be pulled up above 2.0V during normal use.
- (3) The bias pin (pin 23) is muted when lowered below 1.4V (typically). Make sure it stays above 1.6V during normal use.
- (4) Muting occurs during thermal shutdown, mute-on operations or a drop in the bias pin voltage or supply voltage. In each case, only the drivers are muted. During muting, the output pins remain at the internal bias voltage, roughly $(V_{CC}-V_F)/2$.

- (5) The driver circuit shuts down when the supply voltage drops below 4.3V (typically), and starts up again when the voltage rises above 4.5V (typically).
- (6) Fluctuation due to temperature occurs in the gain when using an attached resistor as the input resistor for a driver other than the spindle driver (typically 2200ppm per degree) or for the spindle driver (typically 4600ppm per degree). (Only when using the gain adjustment pin.)
- (7) Be sure to connect the IC to a 0.1μF bypass capacitor to the power supply, at the base of the IC.
- (8) The radiating fin is connected to the package's internal GND, but should also be connected to an external ground.
- (9) The capacitor between regulator output (pin 6) and GND also serves to prevent oscillation of the IC, so select one with good temperature characteristics.

●Electrical characteristic curves

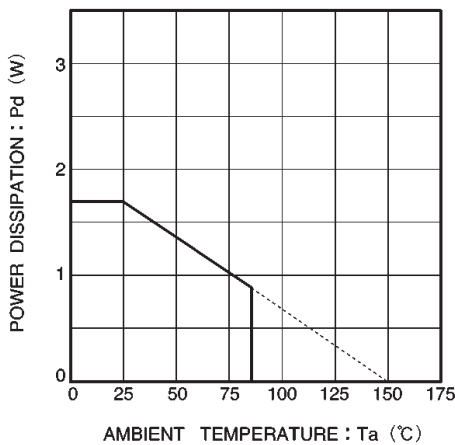

Fig. 9 Thermal derating curve

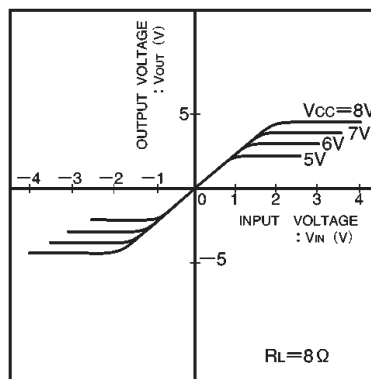

Fig. 10 Driver I/O characteristics (when load changes) (except channel 2)

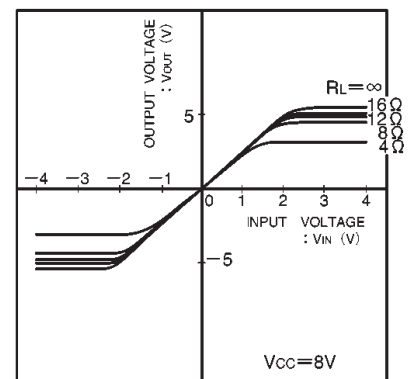

Fig. 11 Driver I/O characteristics (when power supply voltage changes) (except channel 2)

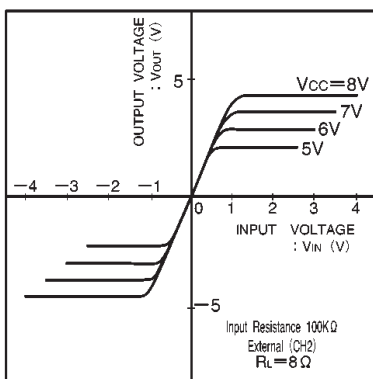

Fig. 12 Driver I/O characteristics (channel 2)

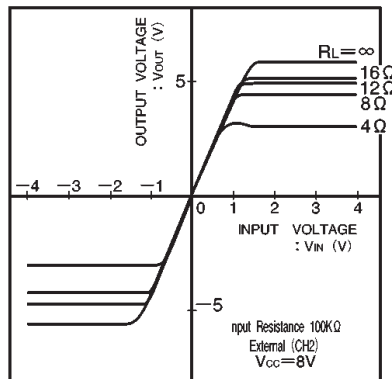

Fig. 13 Driver I/O characteristics (channel 2)

● External dimensions (Units: mm)

