

DESCRIPTION

The LX5261 is a source/sink regulator designed to provide the correct reference voltages and bias currents for SCSI LVD applications. With the proper LVD termination network (475Ω, 121Ω, 475Ω), the LX5261 assures that LVD performance is compliant to the SPI-2 (Ultra2), SPI-3 (Ultra160) and SPI-4 (Ultra320) specification.

The LX5261 provides two fixed regulated outputs (1.75V and 0.75V)

each capable of sourcing / sinking 200mA, along with a buffered 1.3V output for DIFSENS signaling.

The LX5261 features on-chip trimming of the internal voltage enabling precise output voltages; typically +/- 1% of its specified value. Thermal Shutdown and Current Limiting is integrated on-chip.

The LX5261 is available in the 16-pin SOIC (DP) package.

KEY FEATURES

- Compliant with SPI-2 (Ultra2), SPI-3 (Ultra160), and SPI-4 (Ultra320)
- 2.7V to 5.25V Operation
- 200mA Source/Sink Capability
- DIFSENS Line Driver
- Current Limit and Thermal Protection
- Pin Compatible With Unitrode UCC561

IMPORTANT: For the most current data, consult MICROSEMI's website: <http://www.microsemi.com>

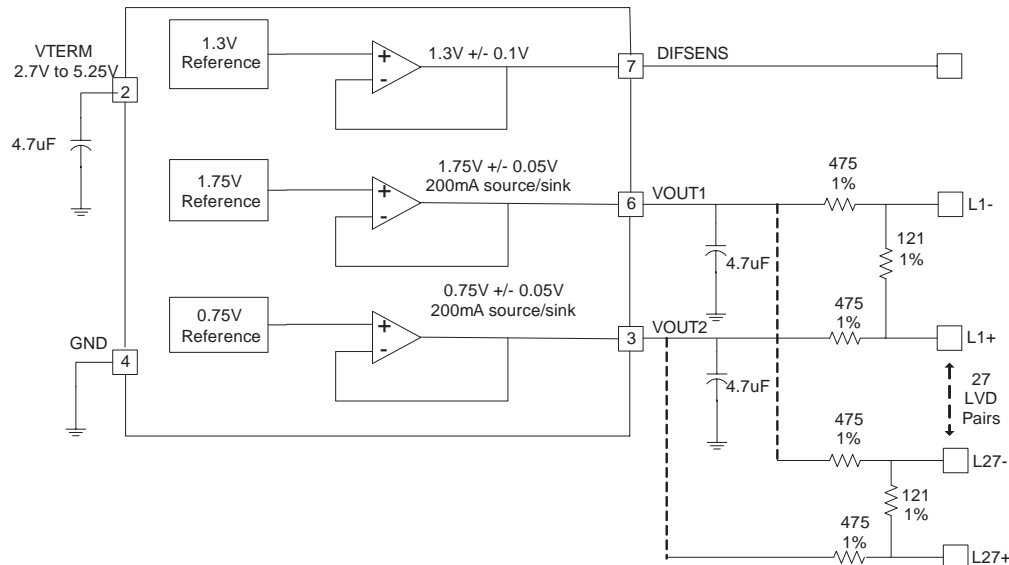
TYPICAL APPLICATION

PACKAGE ORDER INFO

T_A (°C)	DP SOIC
	16-Pin
	RoHS Compliant / Pb-free Transition DC: 0440
0 to 70	LX5261CDP

Note: Available in Tape & Reel.
Append the letters "TR" to the part number. (i.e. LX5261CDP-TR)

ABSOLUTE MAXIMUM RATINGS

Term Power (VTERM)	6V
Operating Junction Temperature	150°C
Storage Temperature Range	-65°C to 150°C
RoHS / Pb-free Peak Package Solder Reflow Temperature (40 second maximum exposure)	260°C (+0, -5)

Note: Exceeding these ratings could cause damage to the device. All voltages are with respect to Ground. Currents are positive into, negative out of specified terminal.

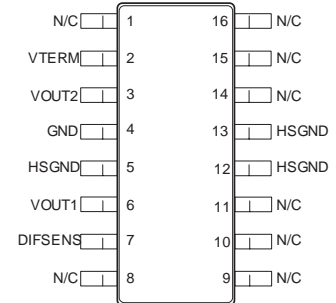
PACKAGE PIN OUT

DP PACKAGE
(Top View)

NC – No Internal Connection

RoHS / Pb-free 100% Matte Tin Lead Finish

THERMAL DATA

DP 16-Pin SOIC

THERMAL RESISTANCE-JUNCTION TO AMBIENT, θ_{JA}

111.8 °C/W

Junction Temperature Calculation: $T_J = T_A + (P_D \times \theta_{JA})$.

The θ_{JA} numbers are guidelines for the thermal performance of the device/pc-board system. All of the above assume no ambient airflow. θ_{JA} can vary significantly depending on mounting technique. (See Application Notes Section: Thermal considerations)

FUNCTIONAL PIN DESCRIPTION

PIN NAME	DESCRIPTION
VOUT1	1.75V Regulated Output. Capable of sourcing/sinking 200mA.
VOUT2	0.75V Regulated Output. Capable of sourcing/sinking 200mA.
VTERM	Power supply pin for terminator. Connect to SCSI bus VTERM. Usually decoupled by one 4.7 μ F low-ESR capacitor. It is absolutely necessary to connect this pin to the decoupling capacitor through a very low impedance (big traces to PCB). Keeping distances very short from the decoupling capacitors is somewhat layout dependent and some applications may benefit from high frequency decoupling with 0.1 μ F capacitors at VTERM pin.
DIFSENS	1.3V buffered output for DIFSENS signaling.
GND	Regulator ground pin. Connect to ground.
HSGND	Attached to die mounting pad, but not bonded to GND pin. Pins should be considered a heat sink only, and not a true ground connection. It is recommended that these pins be connected to ground, but can be left floating.

RECOMMENDED MAX OPERATING CONDITIONS

Parameter	Symbol	LX5261			Units
		Min	Typ	Max	
V _{TERM}	V _{TERM}	2.7		5.25	V
Signal Line Voltage		0		5.0	V
Operating Junction Temperature	T _J	0		70	°C

ELECTRICAL CHARACTERISTICS

Unless otherwise specified, the following specifications apply over the operating ambient temperature $0^{\circ}\text{C} \leq T_A \leq 70^{\circ}\text{C}$, and $V_{\text{TERM}} = 3.3\text{V}$.

Parameter	Symbol	Test Conditions	LX5261			Units
			Min	Typ	Max	
▶ TERMPWR Section						
V _{TERM} Supply Current	I _{TERM}	No Load		35	40	mA
V _{TERM} Voltage	V _{TERM}		2.7		5.25	V
▶ Regulator Section						
1.75V Regulator	V _{REG1}	-125mA < I _{OUT} < 125mA, 2.7V < V _{IN} < 5.25V	1.7	1.75	1.8	V
1.3V Regulator	V _{DIFS}	DIFSENS; No Load	1.2	1.3	1.4	V
0.75V Regulator	V _{REG2}	-125mA < I _{OUT} < 125mA, 2.7V < V _{IN} < 5.25V	0.7	0.75	0.8	V
1.75V Regulator Source Current	I _{SRC1}	V _{OUT} = 1.25V			-200	mA
1.75V Regulator Sink Current	I _{SNK1}	V _{OUT} = 2.25V	200			mA
1.75V Source Current Limit			-700			mA
1.75V Sink Current Limit					700	mA
1.3V Regulator Source Current	I _{DIFS_SRC}	DIFSENS; 0V	-5		-15	mA
1.3V Regulator Sink Current	I _{DIFS_SNK}	DIFSENS = 2.4V	50		200	μA
0.75V Regulator Source Current	I _{SRC2}	V _{OUT} = 0.25V			-200	mA
0.75V Regulator Sink Current	I _{SNK2}	V _{OUT} = 1.25V	200			mA
0.75V Source Current Limit			-700			mA
0.75V Sink Current Limit					700	mA

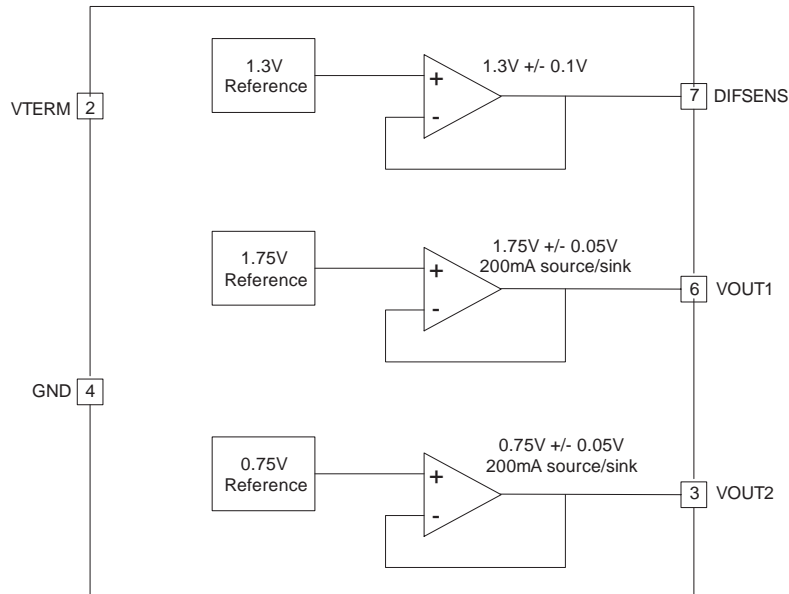
BLOCK DIAGRAM

Figure 1 – LX5261 Block Diagram
APPLICATION INFORMATION
LVD SCSI with Resistor Stack

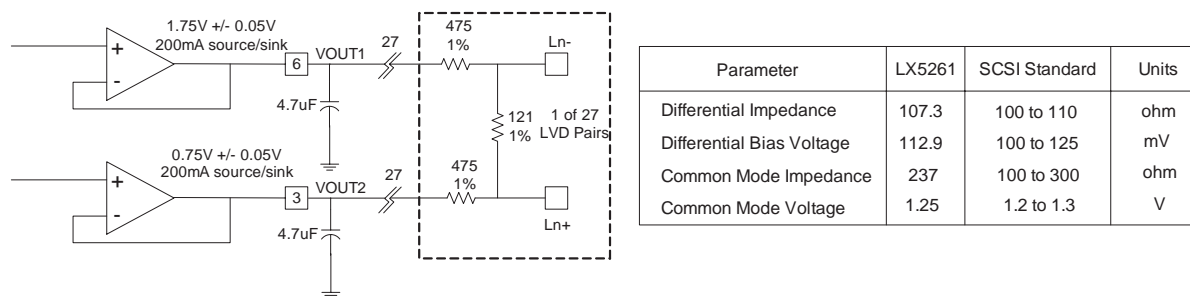
The LX5261 is used with a LVD resistor network (475Ω, 121Ω, 475Ω) to meet LVD SCSI performance. Connecting the top side of the LVD resistor network to the 1.75V regulated output (V_{REG1} , pin 6), and the bottom side of the LVD resistor network to the 0.75V regulated output (V_{REG2} , pin 3) provides the correct bias voltage, differential impedance, common mode differential impedance, and common mode voltage required by the SPI-2 through SPI-4 SCSI specification (see Figure 2. below). The LX5261 is designed to drive up to 27 LVD pairs.

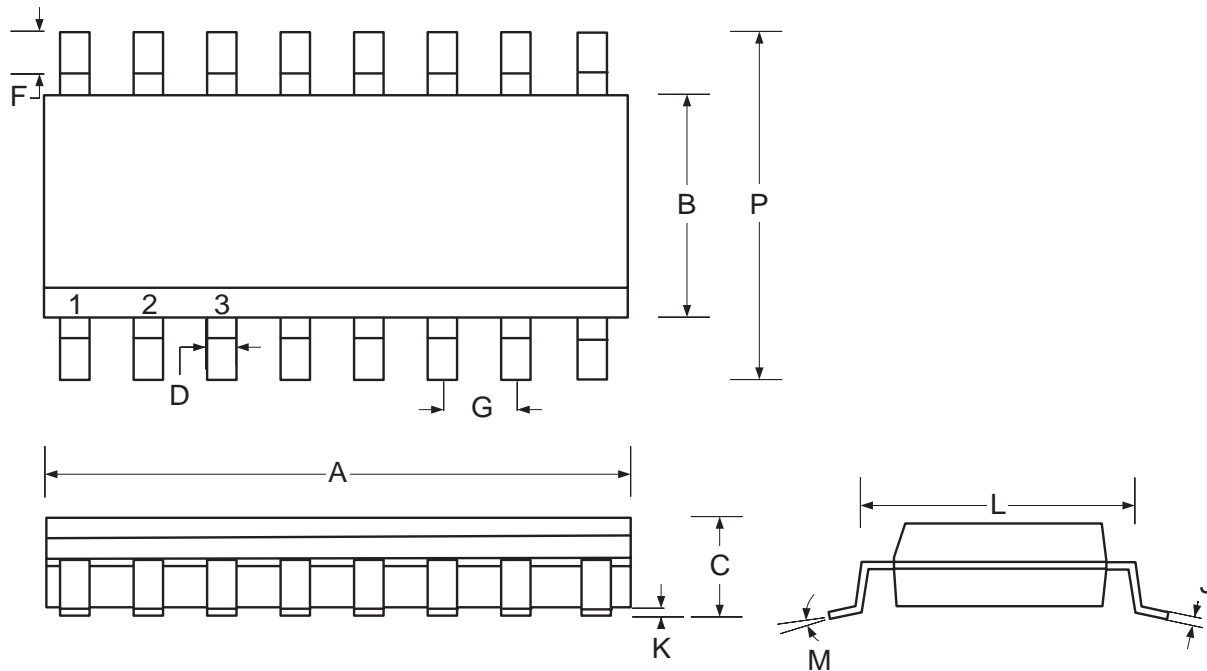
Figure 2 – LX5261 with LVD Resistor Stack

MECHANICAL DRAWINGS
DP 16-Pin Small Outline Package (SOIC) Narrow Body

Dim	MILLIMETERS		INCHES	
	MIN	MAX	MIN	MAX
A	9.78	10.01	0.385	0.394
B	3.81	4.01	0.150	0.158
C	1.35	1.75	0.053	0.069
D	0.35	0.46	0.014	0.018
F		0.77		0.030
G	1.27 BSC		0.050 BSC	
J	0.19	0.25	0.007	0.010
K	0.10	0.25	0.004	0.010
L	4.82	5.21	0.189	0.205
M	0	8	0	8
P	5.79	6.20	0.228	0.244
*LC		0.10		0.004

Note:

1. Dimensions do not include mold flash or protrusions; these shall not exceed 0.155mm (.006") on any side. Lead dimension shall not include solder coverage.



Microsemi[®]

LX5261

27-Line LVD SCSI Source/Sink Regulator

PRODUCTION DATASHEET

NOTES

PRODUCTION DATA – Information contained in this document is proprietary to Microsemi and is current as of publication date. This document may not be modified in any way without the express written consent of Microsemi. Product processing does not necessarily include testing of all parameters. Microsemi reserves the right to change the configuration and performance of the product and to discontinue product at any time.