



Tsi578 Serial RapidIO Switch

Serial RapidIO Interfaces

- 80 Gbits/s aggregate bandwidth
- Low latency with cut-through capability
- Enhanced SerDes for low power solution
- RapidIO Interconnect Specification (Revision 1.3) compliant
- High performance hardware multicast

The Tsi578 enhances system scalability and performance through support for mixed port configurations and extensive fabric management features.

- Error management extensions
 - Proactive issue notification
- Port flexibility fulfills multiple I/O bandwidth requirements:
 - Up to eight 4x mode ports or sixteen 1x mode ports
 - Port frequency configuration to 1.25, 2.5, and 3.125 Gbits/s
 - Support for mixed speed and width configurations
- Integrated high-speed, full-duplex SerDes with 8b/10b encoding
 - Receiver equalization, transmit pre-emphasis, transmit voltage swing
 - IEEE 1149.6 support
 - Lane swap to ease signal layout routing
- Enhanced non-blocking internal switching fabric
 - Traffic management through scheduling algorithms
 - Performance monitoring on individual ports
 - Programmable buffer depth
 - Provisions to eliminate low priority packet starvation
- Supports packet routing tables for 64,000 endpoints

Other Device Capabilities

- I²C Interface
 - Master and Slave
 - Configuration through register initialization
- Hot Swappable Ports
 - Enables use in field replaceable blade applications

The Tsi578 is a third generation RapidIO switch supporting 80 Gbits/s aggregate bandwidth. The Tsi578 is part of a family of switches that enable customers to develop systems with robust features and high performance at low cost.

The Tsi578 provides designers and architects with maximum scalability to design the device into a wide range of applications. Flexible port configurations can be selected through multiple port width and frequency options.

Building on the industry leading Tsi568A™ Serial RapidIO Switch, the Tsi578 contains all the benefits of its predecessor plus enhances the fabric switching capabilities through the addition of multicast, traffic management through scheduling algorithms, programmable buffer depth, and fabric performance monitoring to supervise and manage traffic flow.

Block Diagram

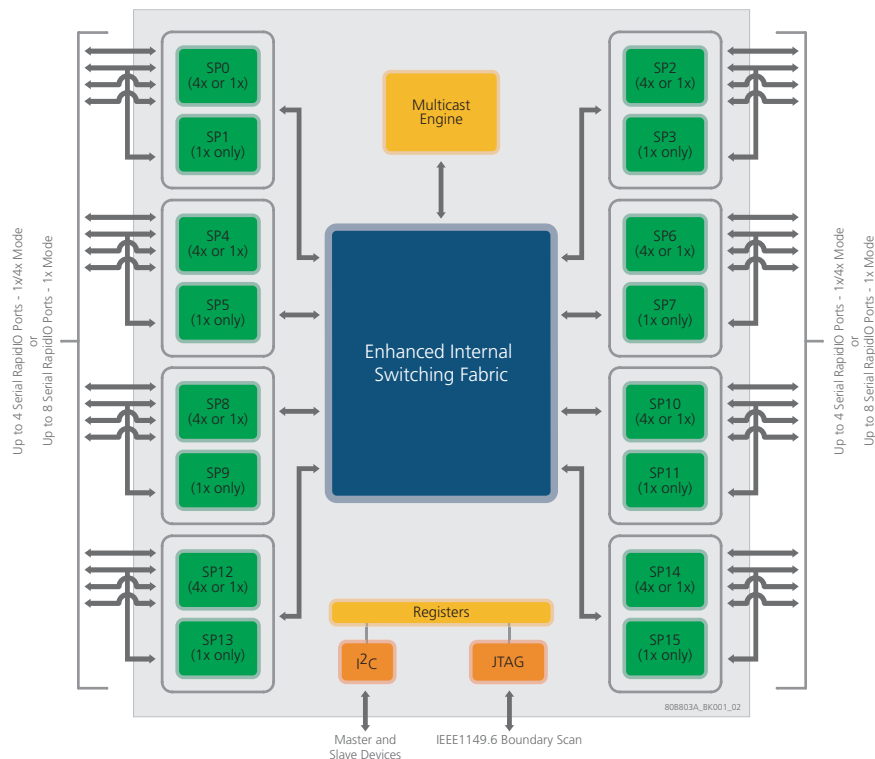

Embedded applications further benefit from the ability to route packets to over 64,000 endpoints through hierarchical lookup tables, independent unicast and multicast routing mechanisms, and error management extensions that provide proactive issue notification to the fabric controller. In addition, the Tsi578 supports both in-band serial RapidIO access and out-of-band access to the full fabric register set through the I²C interface.

Benefits

- Scalability: Single solution for mesh, fabric, and aggregated systems
- Performance: Improved system and distributed processing performance
- Power: SerDes implementation for low power solution

Specifications

- Technology: 0.13u
- Voltage: 1.2V and 3.3V
- Low power consumption
- Package: 675 ball, 27mm x 27mm, 1mm ball pitch FCBGA
- Rated for commercial and industrial temperatures
- Forward compatible with the Tsi568A Serial RapidIO Switch allowing easy migration for existing systems.

Target Markets

Wireless Infrastructure

- Node B, Radio Network Controller, Media Gateway

Communications Wireline Infrastructure

- Multiservice WAN Switches, 1 to 10 Gbit Ethernet Switches, 1 to >10Gbit Routers, DSLAMs

Storage

- Storage Area Networks, Network Attached Storage, High-Performance Work Stations, Multi-service Access Nodes, Carrier-grade VoIP

Video Infrastructure

- Broadcast, imaging, and encoding
- Architecture Standards
- ATCA, MicroTCA, VXS, VPX

Typical Applications

The Tsi578 can be used in many embedded communication applications. It provides chip-to-chip interconnect between I/O devices and can replace existing proprietary backplane fabrics for board-to-board interconnect which improves system cost and product time-to-market.

Processor Farm Mezzanine Diagram

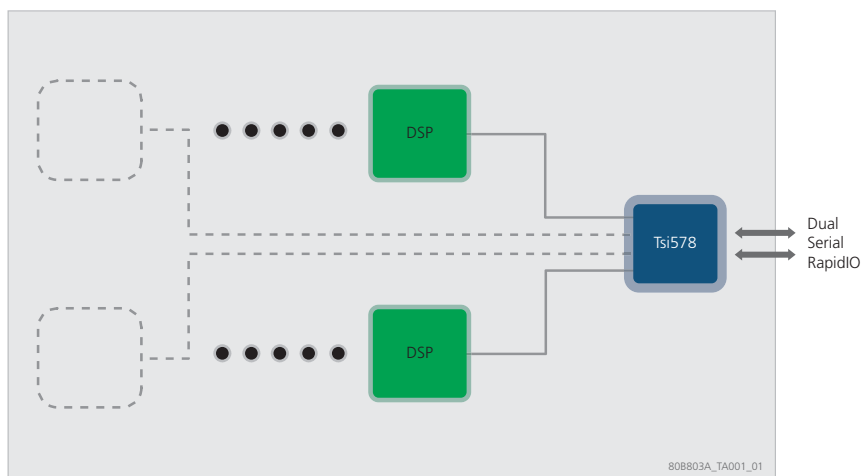

The Tsi578 provides traffic aggregation through packet prioritization when it is used with RapidIO-enabled I/O devices. When it is in a system with multiple RapidIO-enabled processors it provides high performance peer-to-peer communication through its non-blocking switch fabric.

Switch Carrier Blade Diagram

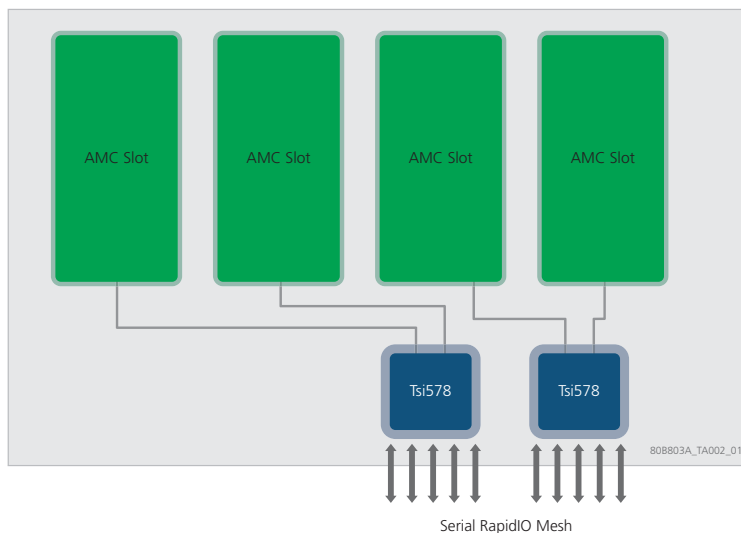

DISCLAIMER Integrated Device Technology, Inc. (IDT) and its subsidiaries reserve the right to modify the products and/or specifications described herein at any time and at IDT's sole discretion. All information in this document, including descriptions of product features and performance, is subject to change without notice. Performance specifications and the operating parameters of the described products are determined in the independent state and are not guaranteed to perform the same way when installed in customer products. The information contained herein is provided without representation or warranty of any kind, whether express or implied, including, but not limited to, the suitability of IDT's products for any particular purpose, an implied warranty of merchantability, or non-infringement of the intellectual property rights of others. This document is presented only as a guide and does not convey any license under intellectual property rights of IDT or any third parties.

IDT's products are not intended for use in life support systems or similar devices where the failure or malfunction of an IDT product can be reasonably expected to significantly affect the health or safety of users. Anyone using an IDT product in such a manner does so at their own risk, absent an express, written agreement by IDT.

Integrated Device Technology, IDT and the IDT logo are registered trademarks of IDT. Other trademarks and service marks used herein, including protected names, logos and designs, are the property of IDT or their respective third party owners.



CORPORATE HEADQUARTERS
6024 Silver Creek Valley Road
San Jose, CA 95138

for SALES:
800-345-7015 or 408-284-8200
fax: 408-284-2775
www.idt.com

for Tech Support:
408-360-1533
sRIO@idt.com
Document: 80B803A_FB001_03