

## Adjustable step-down controller with synchronous rectification

Target Specification

### Features

- Input voltage range from 1.8V to 14V
- Supply voltage range from 4.5V to 14V
- Adjustable output voltage down to 0.6V with  $\pm 0.8\%$  accuracy over line voltage and temperature (0°C~125°C)
- Fixed frequency voltage mode control
- $T_{ON}$  lower than 100ns
- 0% to 100% duty cycle
- Selectable 0.6V or 1.2V internal voltage reference
- External input voltage reference
- Soft-start and inhibit
- High current embedded drivers
- Predictive anti-crossconduction control
- Selectable UVLO threshold (5V or 12V bus)
- Programmable high-side and low-side  $R_{DS(on)}$  sense over-current-protection
- Switching frequency programmable from 100KHz to 1MHz
- Master/slave synchronization with 180° phase shift
- Pre-bias start up capability (L6730C)
- Selectable source/sink or source only capability after soft-start (L6730C)
- Selectable constant current or hiccup mode overcurrent protection after soft-start (L6730D)

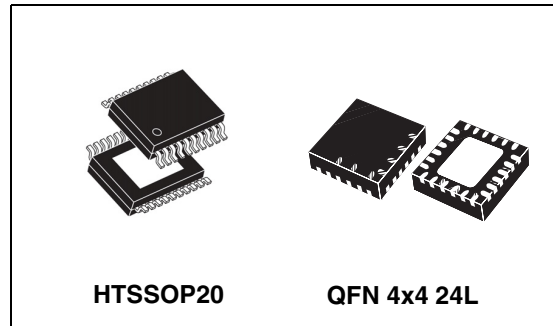

- Power good output with programmable delay
- Over voltage protection with selectable latched/not-latched mode
- Thermal shut-down
- Package: HTSSOP20, QFN4x4 24L

### Applications

- High performance / high density DC-DC modules
- Low voltage distributed DC-DC
- niPOL converters
- DDR memory supply
- DDR memory bus termination supply

### Order Codes

Part number	Package	Packing
L6730CQ	QFN4x4 24L	Tube
L6730CQTR	QFN4x4 24L	Tape & Reel
L6730C	HTSSOP20	Tube
L6730CTR	HTSSOP20	Tape & Reel
L6730D	HTSSOP20	Tube
L6730DTR	HTSSOP20	Tape & Reel

June 2006

Rev 2

1/50

This is preliminary information on a new product foreseen to be developed. Details are subject to change without notice.

[www.st.com](http://www.st.com)

## Contents

<b>1</b>	<b>Summary description</b> .....	<b>4</b>
1.1	Functional description .....	5
<b>2</b>	<b>Electrical data</b> .....	<b>6</b>
2.1	Maximum rating .....	6
2.2	Thermal data .....	6
<b>3</b>	<b>Pin connections and functions</b> .....	<b>7</b>
<b>4</b>	<b>Electrical characteristics</b> .....	<b>10</b>
<b>5</b>	<b>Device description</b> .....	<b>13</b>
5.1	Oscillator .....	13
5.2	Internal LDO .....	14
5.3	Bypassing the LDO to avoid the voltage drop with low Vcc .....	14
5.4	Internal and external references .....	15
5.5	Error amplifier .....	15
5.6	Soft start .....	16
5.7	Driver section .....	19
5.8	Monitoring and protections .....	20
5.9	Adjustable masking time .....	25
5.10	Multifunction pin (S/O/U L6730C) (CC/O/U L6730D) .....	25
5.11	Synchronization .....	26
5.12	Thermal shutdown .....	27
5.13	Minimum on-time (TON, MIN) .....	27
5.14	Bootstrap anti-discharging system .....	28
5.14.1	Fan's power supply .....	28
5.14.2	No-sink at zero current operation .....	29

---

<b>6</b>	<b>Application details</b> .....	<b>30</b>
6.1	Inductor design .....	30
6.2	Output capacitors .....	31
6.3	Input capacitors .....	31
6.4	Compensation network .....	32
6.5	Two quadrant or one quadrant operation mode (L6730C) .....	34
<b>7</b>	<b>L6730 Demoboard</b> .....	<b>35</b>
7.1	Description .....	35
7.2	PCB layout .....	36
<b>8</b>	<b>I/O Description</b> .....	<b>40</b>
<b>9</b>	<b>Efficiency</b> .....	<b>42</b>
<b>10</b>	<b>POL Demoboard</b> .....	<b>44</b>
10.1	Description .....	44
<b>11</b>	<b>Package mechanical data</b> .....	<b>46</b>
<b>12</b>	<b>Revision history</b> .....	<b>49</b>

# 1 Summary description

The controller is an integrated circuit realized in BCD5 (BiCMOS-DMOS, version 5) fabrication that provides complete control logic and protection for high performance step-down DC-DC and niPOL converters.

It is designed to drive N-Channel MOSFETs in a synchronous rectified buck topology. The output voltage of the converter can be precisely regulated down to 600mV with a maximum tolerance of  $\pm 0.8\%$  or to 1.2V, when one of the internal references is used. It is also possible to use an external reference from 0V to 2.5V. The input voltage can range from 1.8V to 14V, while the supply voltage can range from 4.5V to 14V. High peak current gate drivers provide for fast switching to the external power section and the output current can be in excess of 20A, depending on the number of the external MOSFETs used. The PWM duty cycle can range from 0% to 100% with a minimum on-time ( $T_{ON, MIN}$ ) lower than 100ns making possible conversions with very low duty cycle and very high switching frequency.

The device provides voltage-mode control. It includes a 400KHz free-running oscillator that is adjustable from 100KHz to 1MHz. The error amplifier features a 10MHz gain-bandwidth-product and 5V/ $\mu$ s slew-rate that permits to realize high converter bandwidth for fast transient response. The device monitors the current by using the  $R_{DS(on)}$  of both the high-side and low-side MOSFET(s), eliminating the need for a current sensing resistor and guaranteeing an effective over-current-protection in all the application conditions. When necessary, two different current limit protections can be externally set through two external resistors. A leading edge adjustable blanking time is also available to avoid false over-current-protection (OCP) interventions in every application condition. It is possible to select the HICCUP mode or the constant current protection (L6730D) after the soft-start phase.

During the soft-start phase a constant current protection is provided. It is possible to select (before the device turn-on) the sink-source or the source-only mode capability by acting on a multifunction pin (L6730C). The L6730C disables the sink mode capability during the soft-start in order to allow a proper start-up also in pre-biased output voltage conditions. The L6730D can always sink current and so it can be used to supply the DDR Memory BUS termination. Other features are Master-Slave synchronization (with 180° phase shift), Power-Good with adjustable delay, over-voltage-protection, feed-back disconnection, selectable UVLO threshold (5V and 12V Bus) and thermal shutdown. The HTSSOP20 package allows the realization of really compact DC/DC converters.

## 1.1 Functional description

Figure 1. Block diagram

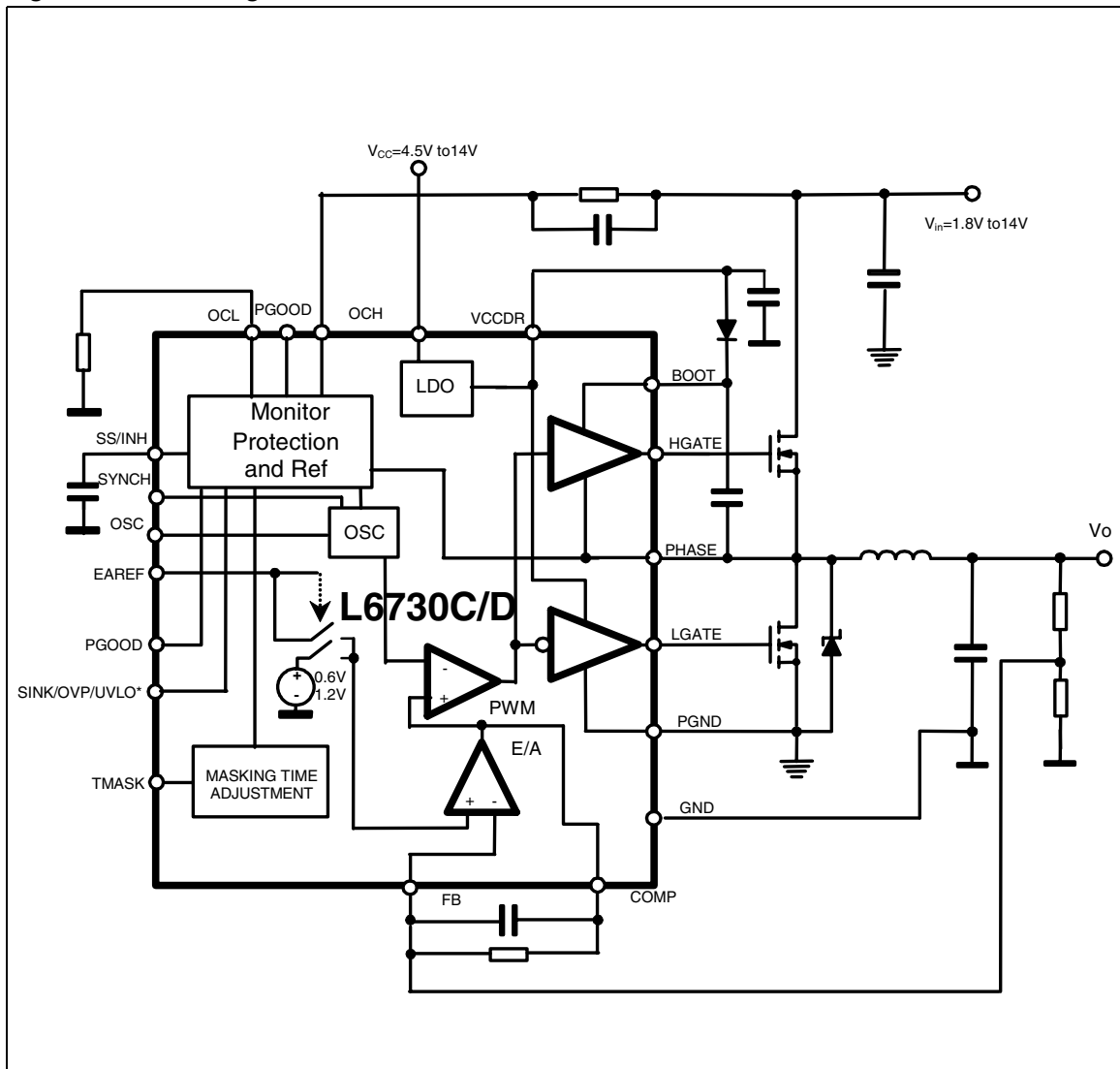

Note: In the L6730D the multifunction pin is: CC/OVP/UVLO.

## 2 Electrical data

### 2.1 Maximum rating

**Table 1. Absolute maximum ratings**

Symbol	Parameter	Value	Unit
$V_{CC}$	$V_{CC}$ to GND and PGND, OCH, PGOOD	-0.3 to 18	V
$V_{BOOT} - V_{PHASE}$	Boot Voltage	0 to 6	V
$V_{HGATE} - V_{PHASE}$		0 to $V_{BOOT} - V_{PHASE}$	V
$V_{BOOT}$	BOOT	-0.3 to 24	V
$V_{PHASE}$	PHASE	-1 to 18	V
	PHASE Spike, transient < 50ns ( $F_{SW} = 500\text{KHz}$ )	-3	
		+24	
	SS, FB, EAREF, SYNC, OSC, OCL, LGATE, COMP, S/O/U, TMASK, PGOODELAY, $V_{CCDR}$	-0.3 to 6	V
OCH Pin	Maximum Withstanding Voltage Range Test Condition: CDF-AEC-Q100-002 "Human Body Model" Acceptance Criteria: "Normal Performance"	$\pm 1500$	V
PGOOD Pin		$\pm 1000$	
OTHER PINS		$\pm 2000$	

### 2.2 Thermal data

**Table 2. Thermal data**

Symbol	Description	HTSSOP20	QFN4x4	Unit
$R_{thJA}^{(1)}$	Max. Thermal Resistance Junction to ambient	50	30	$^{\circ}\text{C}/\text{W}$
$T_{STG}$	Storage temperature range	-40 to +150		$^{\circ}\text{C}$
$T_J$	Junction operating temperature range	-40 to +125		$^{\circ}\text{C}$
$T_A$	Ambient operating temperature range	-40 to +85		$^{\circ}\text{C}$

1. Package mounted on demoboard

### 3 Pin connections and functions

Figure 2. Pins connection (top view)

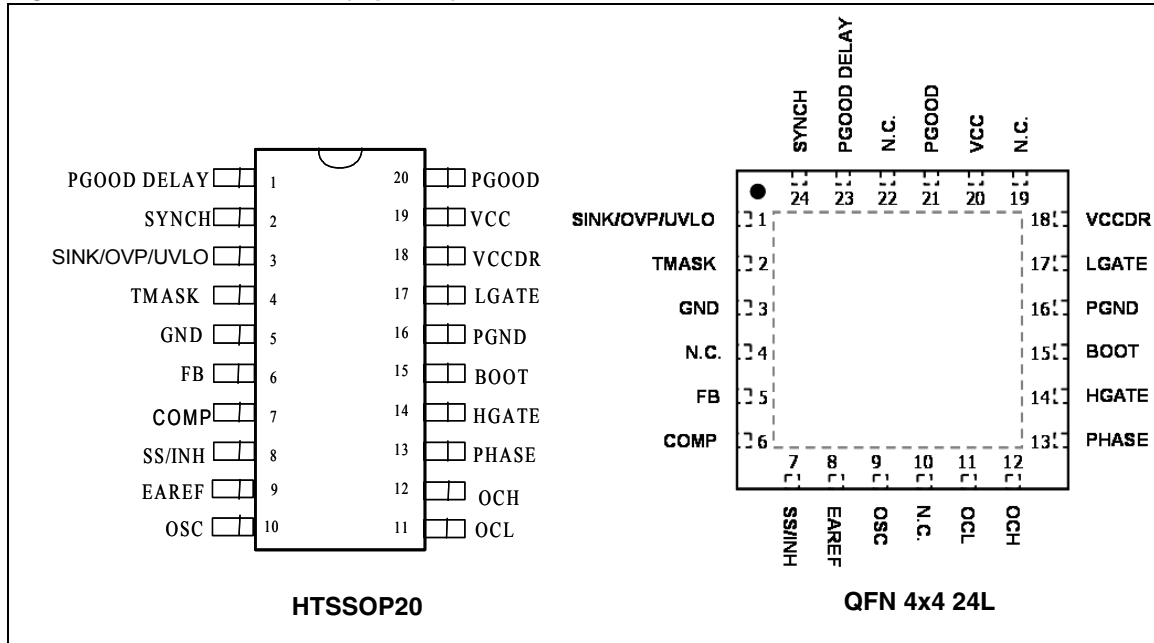

1. In the L6730D the multifunction pin is: CC/OVP/UVLO.

Table 3. Pins connection

Pin n.	Name	Description
1	PGOOD DELAY	Connecting a capacitor between this pin and ground a delay is introduced between the trigger of the internal PGOOD comparator and the external signal rising edge. No delay can be introduced on the falling edge of the PGOOD signal. The delay can be calculated with the following formula: $PGDelay = 0.5 \cdot C(pF) \quad [ \mu s ]$
2	SYNCH	It is a Master-Slave pin. Two or more devices can be synchronized by simply connecting the SYNCH pins together. The device operating with the highest $F_{SW}$ will be the Master. The Slave devices will operate with 180° phase shift from the Master. The best way to synchronize devices together is to set their $F_{SW}$ at the same value. If it is not used the SYNCH pin can be left floating.
3	SINK/OVP/UVLO L6730C CC/OVP/UVLO L6730D	With this pin it is possible: <ul style="list-style-type: none"> <li>– To enable-disable the sink mode current capability after SS (L6730C);</li> <li>– To enable-disable the constant current OCP after SS (L6730D);</li> <li>– To enable-disable the latch mode for the OVP;</li> <li>– To set the UVLO threshold for the 5V BUS and 12V BUS.</li> </ul> The device captures the analog value present at this pin at the start-up when $V_{CC}$ meets the UVLO threshold.

**Table 3. Pins connection**

4	T <sub>MASK</sub>	By connecting this pin to V <sub>CDDR</sub> or ground it is possible to select two different values for the leading edge blanking time on the peak-over-current-protection. The device captures the analog value present at this pin at the start-up when V <sub>CC</sub> meets the UVLO threshold.
5	GND	All the internal references are referred to this pin.
6	FB	This pin is connected to the error amplifier inverting input. Connect it to V <sub>out</sub> through the compensation network. This pin is also used to sense the output voltage in order to manage the over voltage conditions and the PGood signal.
7	COMP	This pin is connected to the error amplifier output and is used to compensate the voltage control loop.
8	SS/INH	The soft-start time is programmed connecting an external capacitor from this pin and GND. The internal current generator forces a current of 10μA through the capacitor. This pin is also used to inhibit the device: when the voltage at this pin is lower than 0.5V the device is disabled.
9	EAREF	It is possible to set two internal references 0.6V / 1.2V or provide an external reference from 0V to 2.5V: – V <sub>EAREF</sub> from 0% to 80% of V <sub>CDDR</sub> ⇒ External Reference – V <sub>EAREF</sub> from 80% to 95% of V <sub>CDDR</sub> ⇒ V <sub>REF</sub> =1.2V – V <sub>EAREF</sub> from 95% to 100% of V <sub>CDDR</sub> ⇒ V <sub>REF</sub> =0.6V An internal clamp limits the maximum V <sub>EAREF</sub> at 2.5V (typ.). The device captures the analog value present at this pin at the start-up when V <sub>CC</sub> meets the UVLO threshold.
10	OSC	Connecting an external resistor from this pin to GND, the external frequency can be increased according with the following equation: $F_{SW} = 400KHz + \frac{9.88 \cdot 10^6}{R_{OSC} (K\Omega)}$ Connecting a resistor from this pin to V <sub>CDDR</sub> (5V), the switching frequency can be lowered according with the following equation: $F_{SW} = 400KHz - \frac{3.01 \cdot 10^7}{R_{OSC} (K\Omega)}$ If the pin is left open, the switching frequency is 400 KHz. Normally this pin is at a voltage of 1.2V. In OVP the pin is pulled up to 4.5V (only in latched mode). Don't connect a capacitor from this pin to GND.



Table 3. Pins connection

11	OCL	<p>A resistor connected from this pin to ground sets the valley-current-limit. The valley current is sensed through the low-side MOSFET(s). The internal current generator sources a current of 100µA (<math>I_{OCL}</math>) from this pin to ground through the external resistor (<math>R_{OCL}</math>). The over-current threshold is given by the following equation:</p> $I_{VALLEY} = \frac{I_{OCL} \cdot R_{OCL}}{2 \cdot R_{DSonLS}}$ <p>Connecting a capacitor from this pin to GND helps in reducing the noise injected from <math>V_{CC}</math> to the device, but can be a low impedance path for the high-frequency noise related to the GND. Connect a capacitor only to a “clean” GND.</p>
12	OCH	<p>A resistor connected from this pin and the high-side MOSFET(s) drain sets the peak-current-limit. The peak current is sensed through the high-side MOSFET(s). The internal 100µA current generator (<math>I_{OCH}</math>) sinks a current from the drain through the external resistor (<math>R_{OCH}</math>). The over-current threshold is given by the following equation:</p> $I_{PEAK} = \frac{I_{OCH} \cdot R_{OCH}}{R_{DSonHS}}$
13	PHASE	This pin is connected to the source of the high-side MOSFET(s) and provides the return path for the high-side driver. This pin monitors the drop across both the upper and lower MOSFET(s) for the current limit together with OCH and OCL.
14	HGATE	This pin is connected to the high-side MOSFET(s) gate.
15	BOOT	Through this pin is supplied the high-side driver. Connect a capacitor from this pin to the PHASE pin and a diode from $V_{CCDR}$ to this pin (cathode versus BOOT).
16	PGND	This pin has to be connected closely to the low-side MOSFET(s) source in order to reduce the noise injection into the device.
17	LGATE	This pin is connected to the low-side MOSFET(s) gate.
18	$V_{CCDR}$	5V internally regulated voltage. It is used to supply the internal drivers and as a voltage reference. Filter it to ground with at least 1µF ceramic cap.
19	$V_{CC}$	Supply voltage pin. The operative supply voltage range is from 4.5V to 14V.
20	PGOOD	This pin is an open collector output and it is pulled low if the output voltage is not within the specified thresholds (90%-110%). If not used it may be left floating. Pull-up this pin to $V_{CCDR}$ with a 10K resistor to obtain a logical signal.

## 4 Electrical characteristics

$V_{CC} = 12V$ ,  $T_A = 25^\circ C$  unless otherwise specified

**Table 4. Electrical characteristics**

Symbol	Parameter	Test condition	Min.	Typ.	Max.	Unit
<b><math>V_{CC}</math> supply current</b>						
$I_{CC}$	$V_{CC}$ Stand By current	OSC = open; SS to GND		4.5	6.5	mA
	$V_{CC}$ quiescent current	OSC= open; HG = open, LG = open, PH=open		8.5	10	
<b>Power-ON</b>						
5V BUS	Turn-ON $V_{CC}$ threshold	$V_{OCH} = 1.7V$	4.0	4.2	4.4	V
	Turn-OFF $V_{CC}$ threshold	$V_{OCH} = 1.7V$	3.6	3.8	4.0	
12V BUS	Turn-ON $V_{CC}$ threshold	$V_{OCH} = 1.7V$	8.3	8.6	8.9	
	Turn-OFF $V_{CC}$ threshold	$V_{OCH} = 1.7V$	7.4	7.7	8.0	
$V_{IN\ OK}$	Turn-ON $V_{OCH}$ threshold		1.1	1.25	1.47	
	Turn-OFF $V_{OCH}$ threshold		0.9	1.05	1.27	
<b><math>V_{CCDR}</math> Regulation</b>						
	$V_{CCDR}$ voltage	$V_{CC} = 5.5V$ to $14V$ $I_{DR} = 1mA$ to $100mA$	4.5	5	5.5	V
<b>Soft Start and Inhibit</b>						
$I_{SS}$	Soft Start Current	SS = 2V	7	10	13	$\mu A$
		SS = 0 to 0.5V	20	30	45	
<b>Oscillator</b>						
$f_{OSC}$	Initial Accuracy	OSC = OPEN	380	400	420	KHz
$f_{OSC,RT}$	Total Accuracy	RT = 390K $\Omega$ to $V_{CCDR}$ RT = 18K $\Omega$ to GND	-15		15	%
$\Delta V_{OSC}$	Ramp Amplitude			2.1		V
<b>Output Voltage (1.2V MODE)</b>						
$V_{FB}$	Output Voltage		1.190	1.2	1.208	V
<b>Output Voltage (0.6 MODE)</b>						
$V_{FB}$	Output Voltage		0.597	0.6	0.603	V

Table 4. Electrical characteristics

Symbol	Parameter	Test Condition	Min.	Typ.	Max.	Unit
<b>Error Amplifier</b>						
$R_{EAREF}$	EAREF Input Resistance	Vs. GND	70	100	150	k $\Omega$
$I_{FB}$	I.I. bias current	$V_{FB} = 0V$		0.290	0.5	$\mu A$
Ext Ref Clamp			2.3			V
$V_{OFFSET}$	Error amplifier offset	$V_{ref} = 0.6V$	-5		+5	mV
$G_V$	Open Loop Voltage Gain	Guaranteed by design		100		dB
GBWP	Gain-Bandwidth Product	Guaranteed by design		10		MHz
SR	Slew-Rate	COMP = 10pF Guaranteed by design		5		V/ $\mu s$
<b>Gate Drivers</b>						
$R_{HGATE\_ON}$	High Side Source Resistance	$V_{BOOT} - V_{PHASE} = 5V$		1.7		$\Omega$
$R_{HGATE\_OFF}$	High Side Sink Resistance	$V_{BOOT} - V_{PHASE} = 5V$		1.12		$\Omega$
$R_{LGATE\_ON}$	Low Side Source Resistance	$V_{CCDR} = 5V$		1.15		$\Omega$
$R_{LGATE\_OFF}$	Low Side Sink Resistance	$V_{CCDR} = 5V$		0.6		$\Omega$
<b>Protections</b>						
$I_{OCH}$	OCH Current Source	$V_{OCH} = 1.7V$	90	100	110	$\mu A$
$I_{OCL}$	OCL Current Source		90	100	110	$\mu A$
OVP	Over Voltage Trip ( $V_{FB} / V_{EAREF}$ )	$V_{FB}$ Rising $V_{EAREF} = 0.6V$		120		%
		$V_{FB}$ Falling $V_{EAREF} = 0.6V$		117		%
$I_{OSC}$	OSC Sourcing Current	$V_{FB} > OVP$ Trip $V_{OSC} = 3V$		30		mA
<b>Power Good</b>						
	Upper Threshold ( $V_{FB} / V_{EAREF}$ )	$V_{FB}$ Rising	108	110	112	%
	Lower Threshold ( $V_{FB} / V_{EAREF}$ )	$V_{FB}$ Falling	88	90	92	%
$V_{PGOOD}$	PGOOD Voltage Low	$I_{PGOOD} = -5mA$		0.5		V

**Table 5. Thermal characterizations ( $V_{CC} = 12V$ )**

Symbol	Parameter	Test Condition	Min	Typ	Max	Unit
<b>Oscillator</b>						
$f_{OSC}$	Initial Accuracy	OSC = OPEN; $T_J = 0^{\circ}C \sim 125^{\circ}C$	376	400	424	KHz
<b>Output Voltage (1.2V MODE)</b>						
$V_{FB}$	Output Voltage	$T_J = 0^{\circ}C \sim 125^{\circ}C$	1.188	1.2	1.212	V
		$T_J = -40^{\circ}C \sim 125^{\circ}C$	1.185	1.2	1.212	V
<b>Output Voltage (0.6V MODE)</b>						
$V_{FB}$	Output Voltage	$T_J = 0^{\circ}C \sim 125^{\circ}C$	0.596	0.6	0.605	V
		$T_J = -40^{\circ}C \sim 125^{\circ}C$	0.593	0.6	0.605	V

## 5 Device description

### 5.1 Oscillator

The switching frequency is internally fixed to 400KHz. The internal oscillator generates the triangular waveform for the PWM charging and discharging an internal capacitor ( $F_{SW} = 400\text{KHz}$ ). This current can be varied using an external resistor ( $R_T$ ) connected between OSC pin and GND or  $V_{CCDR}$  in order to change the switching frequency. Since the OSC pin is maintained at fixed voltage (typ. 1.2V), the frequency is increased (decreased) proportionally to the current sunk (sourced) from (into) the pin. In particular, connecting  $R_T$  versus GND the frequency is increased (current is sunk from the pin), according to the following relationship:

$$F_{SW} = 400\text{KHz} + \frac{9.88 \cdot 10^6}{R_{OSC}(\text{K}\Omega)} \quad (1)$$

Connecting  $R_T$  to  $V_{CCDR}$  the frequency is reduced (current is sourced into the pin), according to the following relationship:

$$F_{SW} = 400\text{KHz} - \frac{3.01 \cdot 10^7}{R_{OSC}(\text{K}\Omega)} \quad (2)$$

Switching frequency variation vs.  $R_T$  is shown in [Figure 3](#).

**Figure 3. Switching frequency variation versus  $R_T$ .**

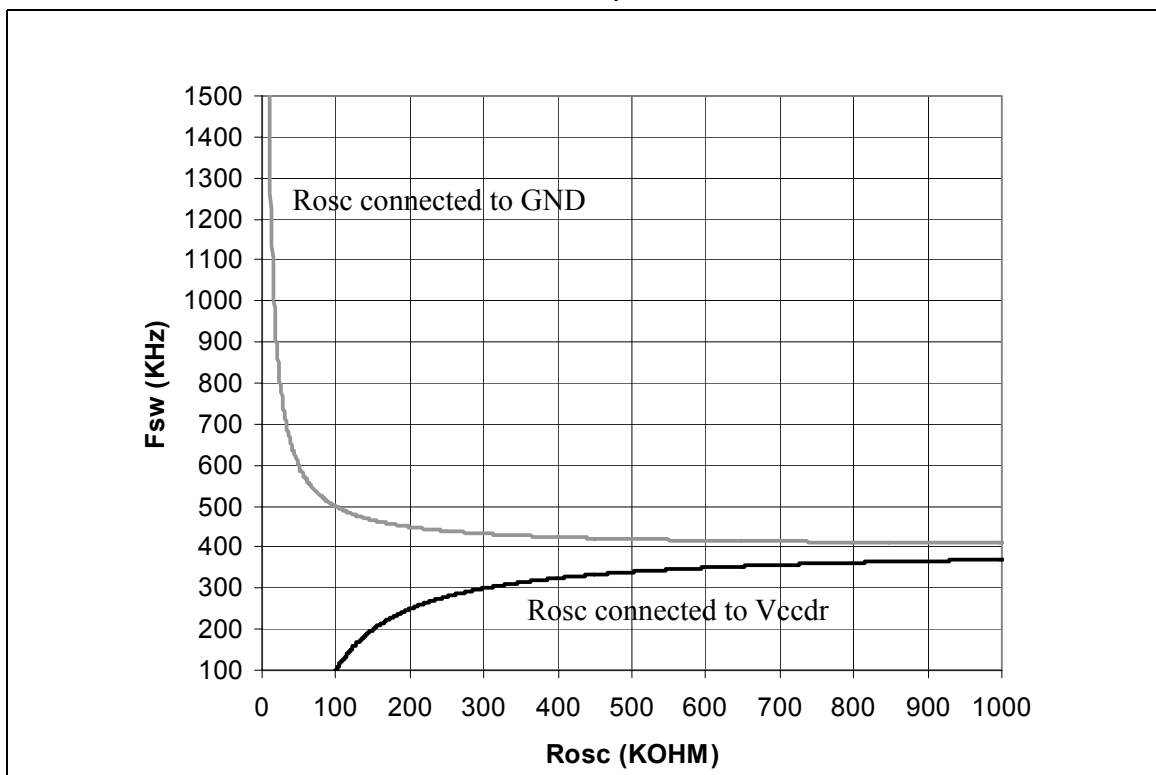

## 5.2 Internal LDO

An internal LDO supplies the internal circuitry of the device. The input of this stage is the  $V_{CC}$  pin and the output (5V) is the  $V_{CCDR}$  pin (see [Figure 4.](#)).

**Figure 4. LDO block diagram.**

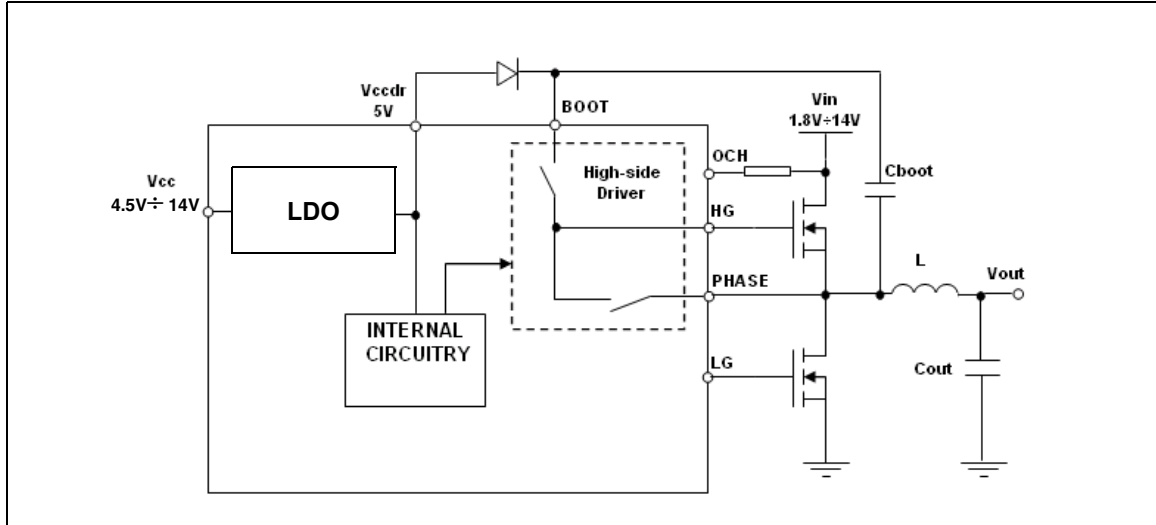

## 5.3 Bypassing the LDO to avoid the voltage drop with low Vcc

The LDO can be by-passed, providing directly a 5V voltage to  $V_{CCDR}$ . In this case  $V_{CC}$  and  $V_{CCDR}$  pins must be shorted together as shown in [Figure 5.](#)  $V_{CCDR}$  pin must be filtered with at least  $1\mu\text{F}$  capacitor to sustain the internal LDO during the recharge of the bootstrap capacitor.  $V_{CCDR}$  also represents a voltage reference for Tmask pin, S/O/U pin (L6730C) or CC/O/U pin (L6730D) and PGOOD pin (see [Table 3: Pins connection](#)).

If  $V_{CC} \approx 5\text{V}$  the internal LDO works in dropout with an output resistance of about  $1\Omega$ .

The maximum LDO output current is about 100mA and so the output voltage drop can be 100mV: to avoid this the LDO can be bypassed.

**Figure 5. Bypassing the LDO**

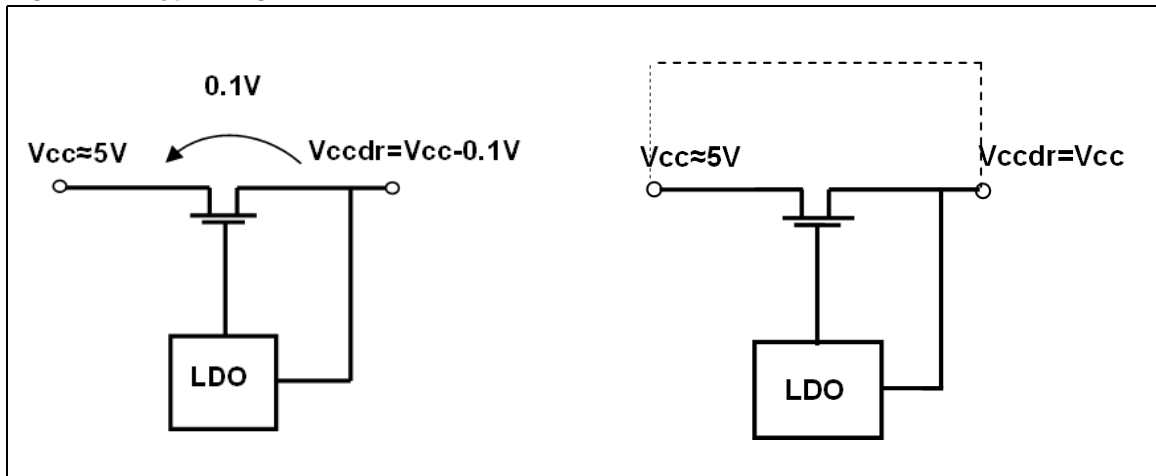

## 5.4 Internal and external references

It is possible to set two internal references, 0.6V and 1.2V or provide an external reference from 0V to 2.5V. The maximum value of the external reference depends on the  $V_{CC}$ : with  $V_{CC} = 4V$  the clamp operates at about 2V (typ.), while with  $V_{CC}$  greater than 5V the maximum external reference is 2.5V (typ.).

- $V_{EAREF}$  from 0% to 80% of  $V_{CCDR} \Rightarrow$  External reference
- $V_{EAREF}$  from 80% to 95% of  $V_{CCDR} \Rightarrow V_{REF} = 1.2V$
- $V_{EAREF}$  from 95% to 100% of  $V_{CCDR} \Rightarrow V_{REF} = 0.6V$

Providing an external reference from 0V to 450mV the output voltage will be regulated but some restrictions must be considered:

- The minimum OVP threshold is set at 300mV;
- The under-voltage-protection doesn't work;
- The PGOOD signal remains low;

To set the resistor divider it must be considered that a 100K pull-down resistor is integrated into the device (see [Figure 6](#)). Finally it must be taken into account that the voltage at the EAREF pin is captured by the device at the start-up when  $V_{cc}$  is about 4V.

## 5.5 Error amplifier

Figure 6. Error amplifier reference

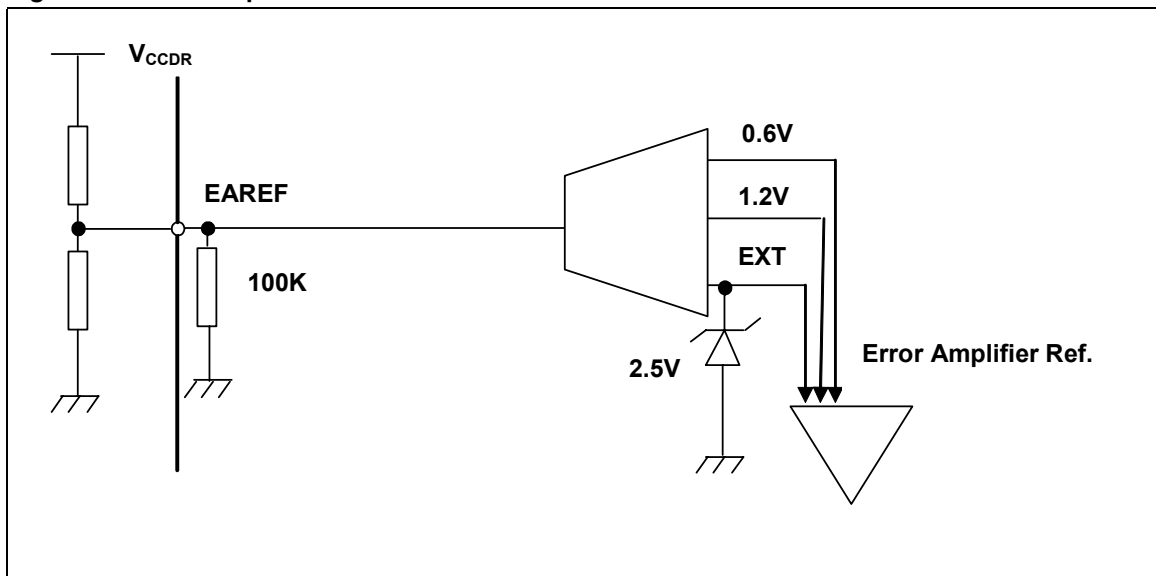

## 5.6 Soft start

When both  $V_{CC}$  and  $V_{IN}$  are above their turn-ON thresholds ( $V_{IN}$  is monitored by the OCH pin) the start-up phase takes place. Otherwise the SS pin is internally shorted to GND. At start-up, a ramp is generated charging the external capacitor  $C_{SS}$  with an internal current generator. The initial value for this current is  $35\mu\text{A}$  and charges the capacitor up to  $0.5\text{V}$ . After that it becomes  $10\mu\text{A}$  until the final charge value of approximately  $4\text{V}$  (see [Figure 7](#)).

Figure 7. Device start-up: Voltage at the SS pin.

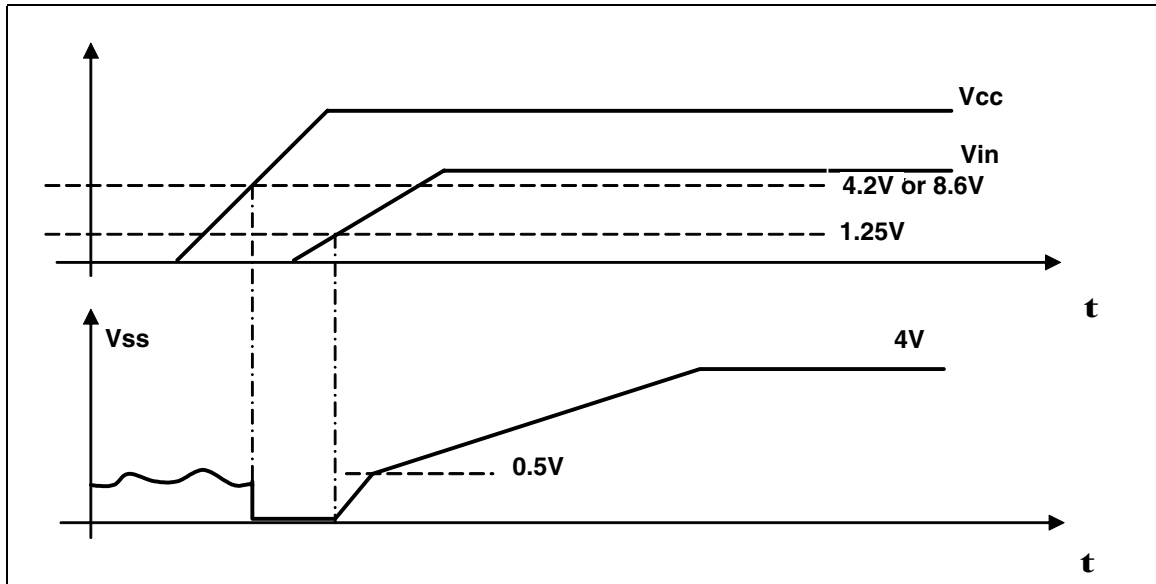



The reference of the error amplifier is clamped with this voltage ( $V_{SS}$ ) until it reaches the programmed value: 0.6V or 1.2V. During the soft-start phase the converter works in closed loop. The L6730C can only source current during the soft-start phase in order to manage the prebias start-up applications. The L6730D can always sink current and so it can be used to supply the DDR Memory termination BUS. If an over current is detected during the soft-start phase, the device provides a constant-current-protection. In this way, in case of short soft-start time and/or small inductor value and/or high output capacitors value and thus, in case of high ripple current during the soft-start, the converter can start-up in any case, limiting the current (see section 4.5 Monitoring and protections) but not entering in HICCUP mode. The soft-start phase ends when  $V_{SS}$  reaches 3.5V. After that the over-current-protection triggers the HICCUP mode (L6730C). With the L6730D there is the possibility to set the HICCUP mode or the constant current mode after the soft-start acting on the multifunction pin CC/O/U. With the L6730 the low-side MOSFET(s) management after soft-start phase depends on the S/O/U pin state (see related section). If the sink-mode is enabled the converter can sink current after soft-start (see figure 9) while, if the sink-mode is disabled the converter never sinks current (see figure 10)..

**Figure 8. Sink-mode enabled: Inductor current during and after soft-start (L6730C).**

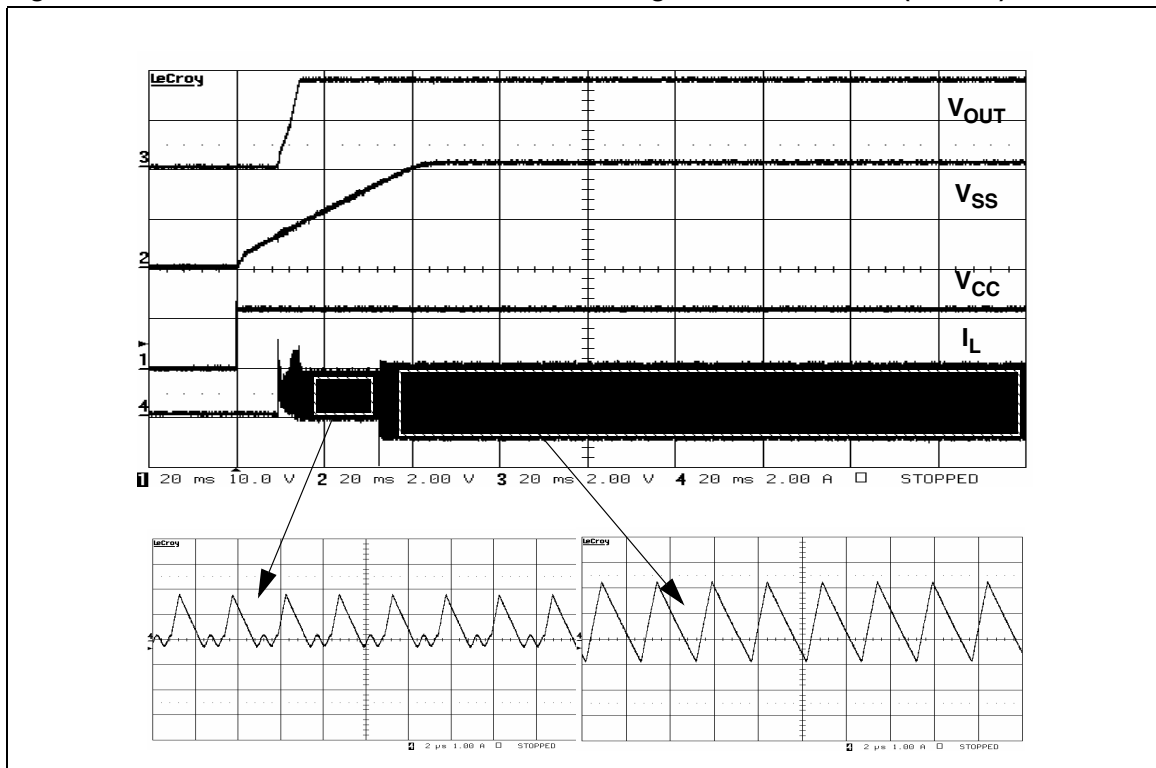
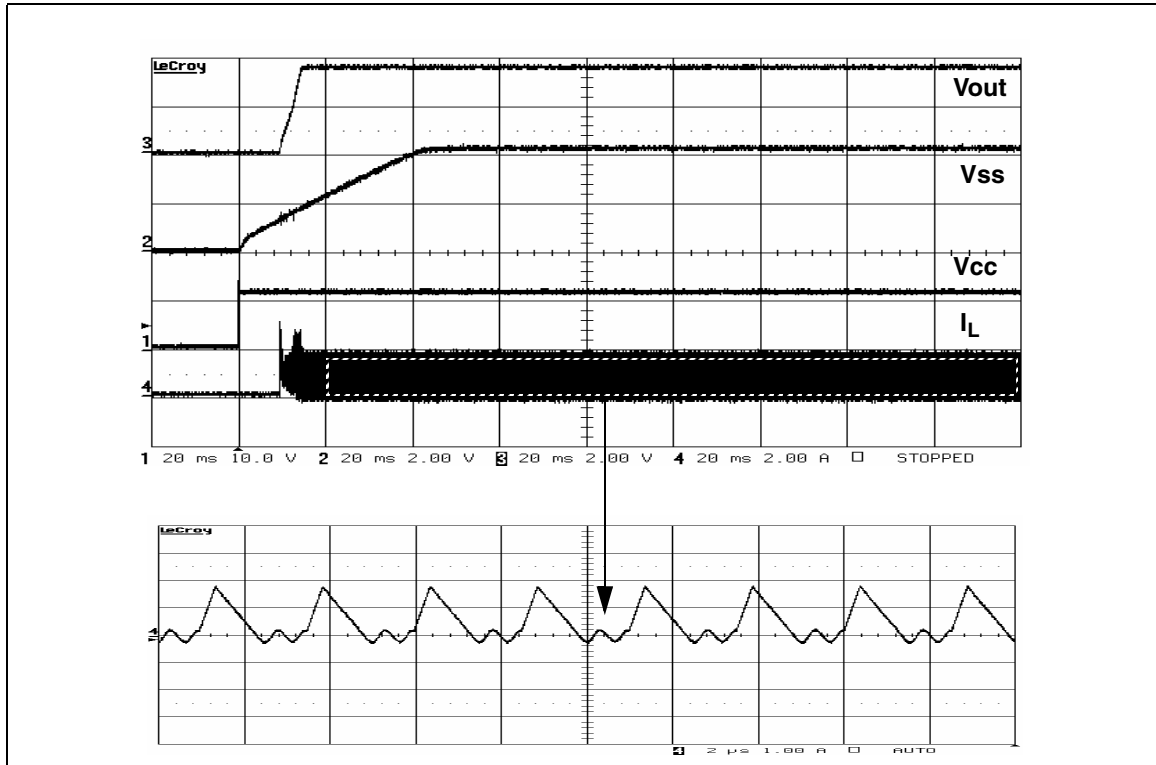

Figure 9. Sink-mode disabled: Inductor current during and after soft-start (L6730C).



During normal operation, if any under-voltage is detected on one of the two supplies ( $V_{CC}$ ,  $V_{IN}$ ), the SS pin is internally shorted to GND by an internal switch and so the SS capacitor is rapidly discharged. Two different turn-on UVLO thresholds can be set: 4.2V for 5V BUS and 8.6V for 12V BUS.

## 5.7 Driver section

The high-side and low-side drivers allow using different types of power MOSFETs (also multiple MOSFETs to reduce the  $R_{DS(on)}$ ), maintaining fast switching transitions. The low-side driver is supplied by  $V_{CCDR}$  while the high-side driver is supplied by the BOOT pin. A predictive dead time control avoids MOSFETs cross-conduction maintaining very short dead time duration (see [Figure 10](#)).

Figure 10. Dead times

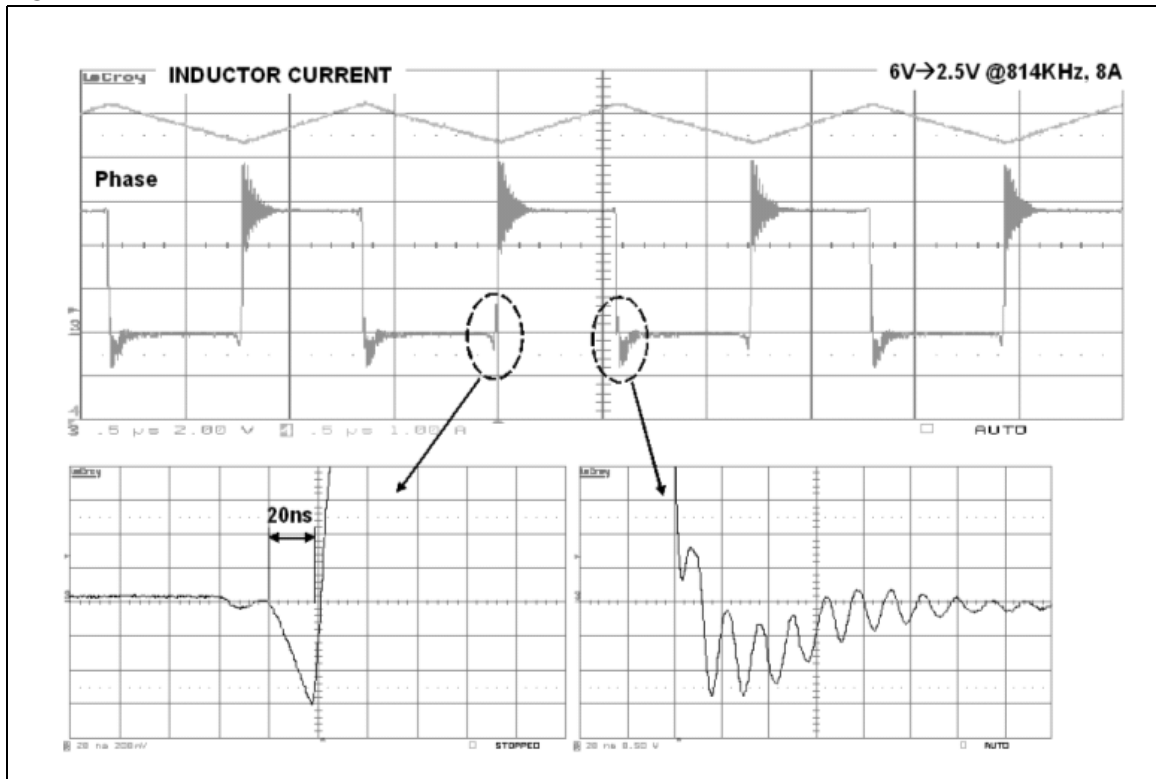

The control monitors the phase node in order to sense the low-side body diode recirculation. If the phase node voltage is less than a certain threshold (-350mV typ.) during the dead time, it will be reduced in the next PWM cycle. The predictive dead time control doesn't work when the high-side body diode is conducting because the phase node doesn't go negative. This situation happens when the converter is sinking current for example and, in this case, an adaptive dead time control operates.

### 5.8 Monitoring and protections

The output voltage is monitored by the FB pin. If it is not within ±10% (typ.) of the programmed value, the Power-Good (PGOOD) output is forced low. The PGOOD signal can be delayed by adding an external capacitor on PGDelay pin (see [Table 3: Pins connection](#) and [Figure 11.](#)); this can be useful to perform cascade sequencing. The delay can be calculated with the following formula:

$$PGDelay = 0.5 \cdot C(pF) \text{ [pF]} \quad (3)$$

Figure 11. PGOOD signal

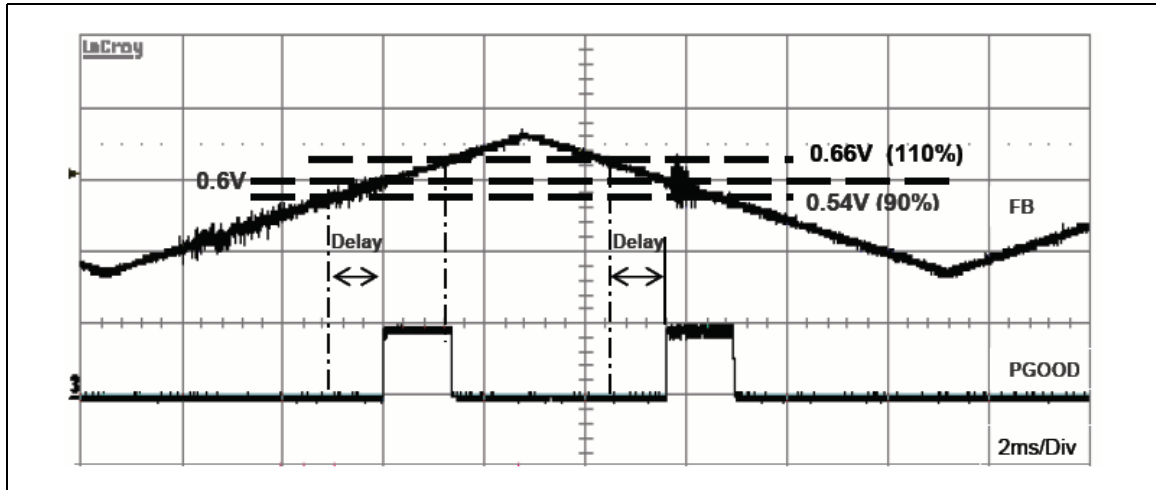

The device provides over-voltage-protection: when the voltage sensed on FB pin reaches a value 20% (typ.) greater than the reference, the low-side driver is turned on. If the OVP not-latched mode has been set the low-side MOSFET is kept on as long as the over voltage is detected (see [Figure 12.](#)). If OVP latched-mode has been set the low-side MOSFET is turned on until Vcc is toggled (see [Figure 13.](#)). In case of latched-mode OVP the OSC pin is forced high (4.5V typ.) if an over voltage is detected. .

Figure 12. OVP not latched

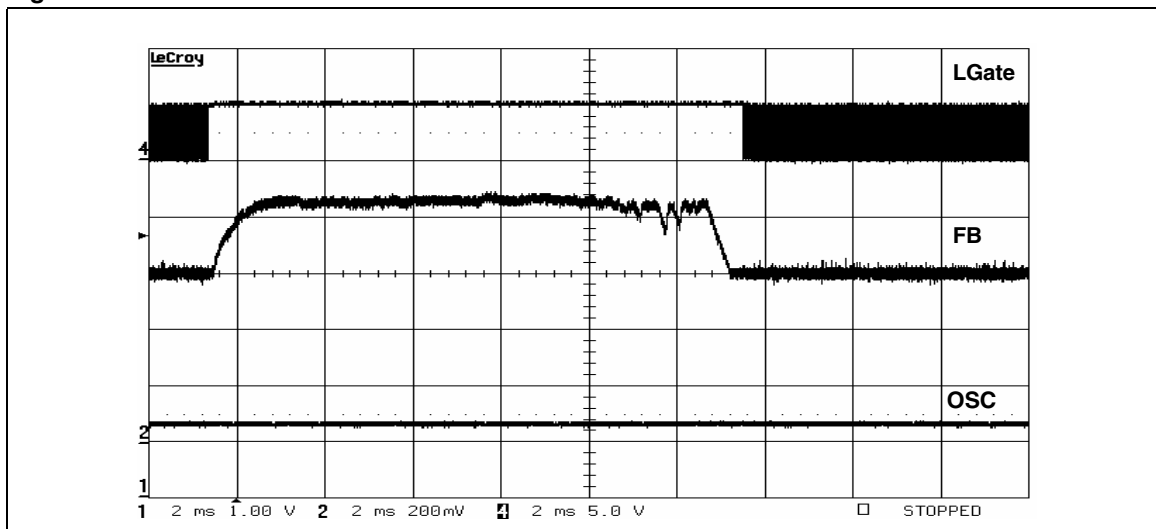
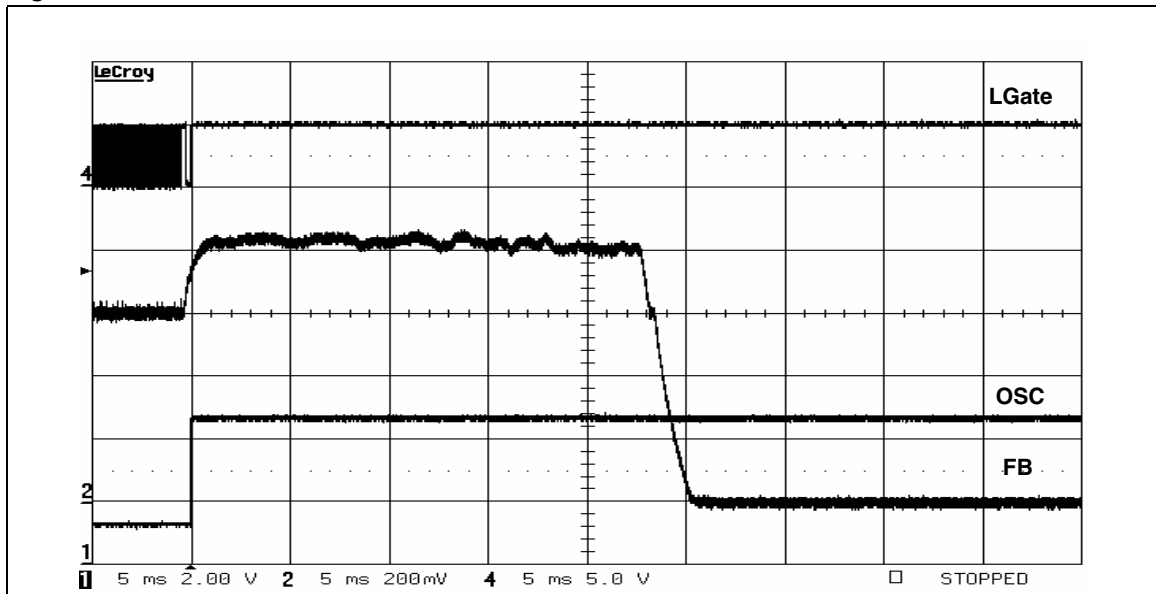

Figure 13. OVP latched



It must be taken into account that there is an electrical network between the output terminal and the FB pin and therefore the voltage at this pin is not a perfect replica of the output voltage. If the converter can sink current, in the most of cases the low-side will be turned-on before the output voltage exceeds the over-voltage threshold, because the error amplifier will throw off balance in advance. Even if the device doesn't report an over-voltage, the behaviour is the same, because the low-side is turned-on immediately. Instead, if the sink-mode is disabled, the low-side will be turned-on only when the over-voltage-protection (OVP) operates and not before, because the current can't be reversed. In this case a delay between the output voltage rising and the FB voltage rising can appear and the OVP can operate on late. The following two figures show an over-voltage event in case of sink enabled and disabled. The output voltage rises with a slope of  $100\text{mV}/\mu\text{s}$ , emulating in this way the breaking of the high-side MOSFET as an over-voltage cause.

Figure 14. OVP with sink enabled: the low-side MOSFET is turned-on in advance.

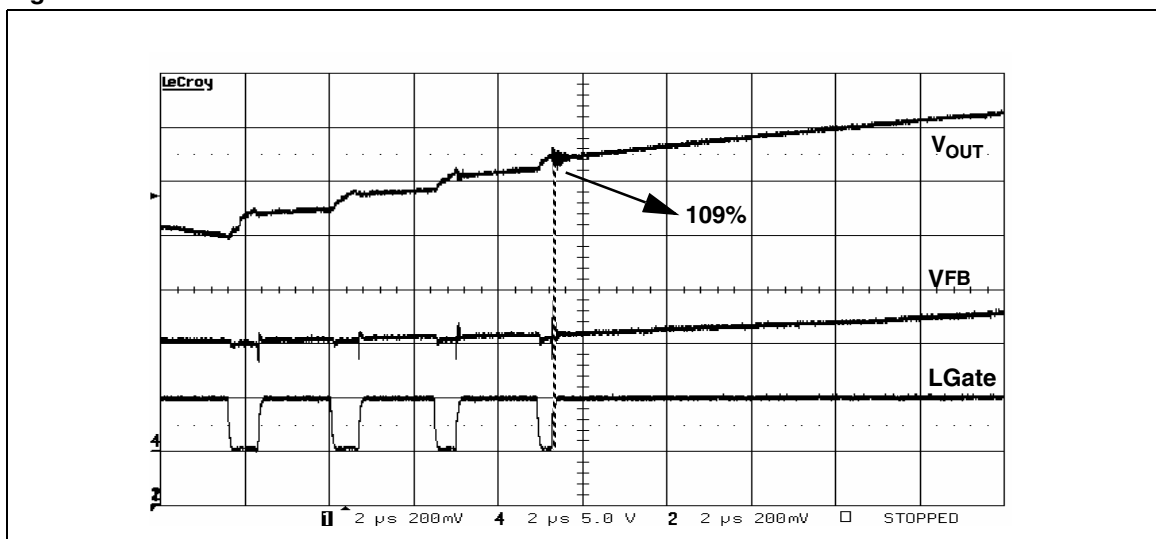
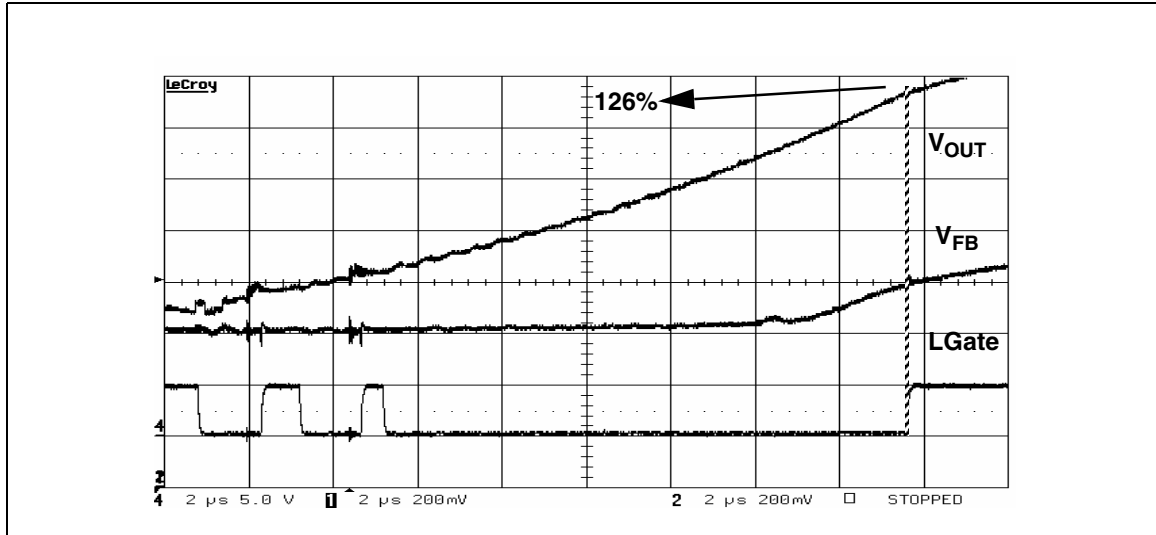

Figure 15. OVP with sink disabled: delay on the OVP operation.



The L6730D can always sink current and so the OVP will operate always in advance. The device realizes the over-current-protection (OCP) sensing the current both on the high-side MOSFET(s) and the low-side MOSFET(s) and so 2 current limit thresholds can be set (see OCH pin and OCL pin in [Table 3: Pins connection](#)):

- Peak Current Limit
- Valley Current Limit

The Peak Current Protection is active when the high-side MOSFET(s) is turned on, after an adjustable masking time (see [Chapter 5.10 on page 25](#)). The valley-current-protection is enabled when the low-side MOSFET(s) is turned on after a fix masking time of about 400ns. If, when the soft-start phase is completed, an over current event occurs during the on time (peak-current-protection) or during the off time (valley-current-protection) the device enters in HICCUP mode (L6730C): the high-side and low-side MOSFET(s) are turned off, the soft-start capacitor is discharged with a constant current of 10μA and when the voltage at the SS pin reaches 0.5V the soft-start phase restarts. During the soft-start phase the OCP provides a constant-current-protection. If during the  $T_{ON}$  the OCH comparator triggers an over current the high-side MOSFET(s) is immediately turned-off (after the masking time and the internal delay) and returned-on at the next pwm cycle. The limit of this protection is that the  $T_{on}$  can't be less than masking time plus propagation delay (see [Chapter 5.9: Adjustable masking time on page 25](#)) because during the masking time the peak-current-protection is disabled. In case of very hard short circuit, even with this short  $T_{ON}$ , the current could escalate. The valley-current-protection is very helpful in this case to limit the current. If during the off-time the OCL comparator triggers an over current, the high-side MOSFET(s) is not turned-on until the current is over the valley-current-limit. This implies that, if it is necessary, some pulses of the high-side MOSFET(s) will be skipped, guaranteeing a maximum current due to the following formula:

$$I_{MAX} = I_{VALLEY} + \frac{V_{in} - V_{out}}{L} \cdot T_{ON,MIN} \quad (4)$$

In constant current protection a current control loop limits the value of the error amplifier's output (comp), in order to avoid its saturation and thus recover faster when the output returns in regulation. [Figure 16](#) shows the behaviour of the device during an over current condition that persists also in the soft-start phase.

Figure 16. Constant current and Hiccup Mode during an OCP (L6730C).

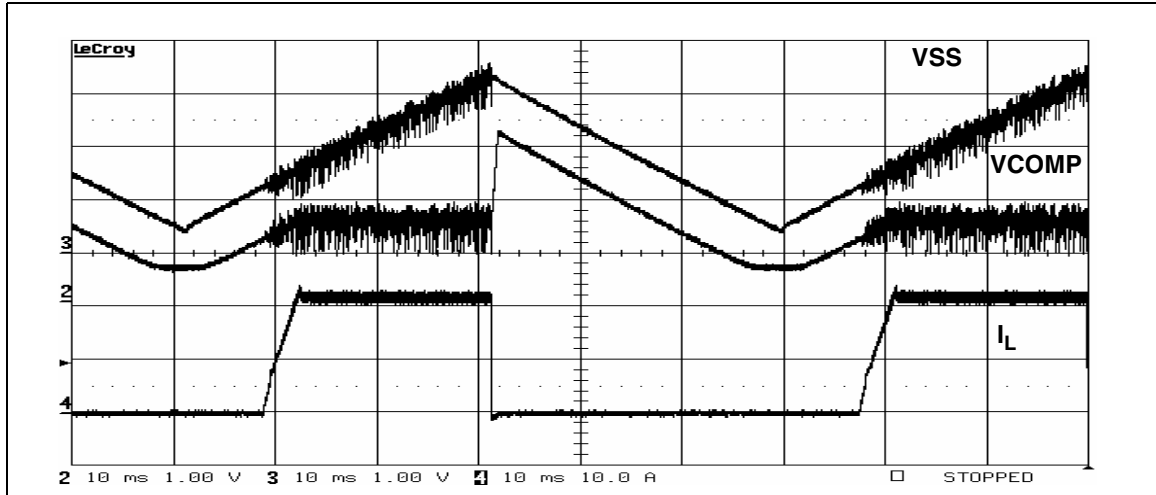

Using the L6730D there is the possibility to set the constant-current-protection also after the soft-start. The following figures show the behaviour of the L6730D during an overcurrent event.

Figure 17. Peak overcurrent-protection in constant-current-protection (L6730D).

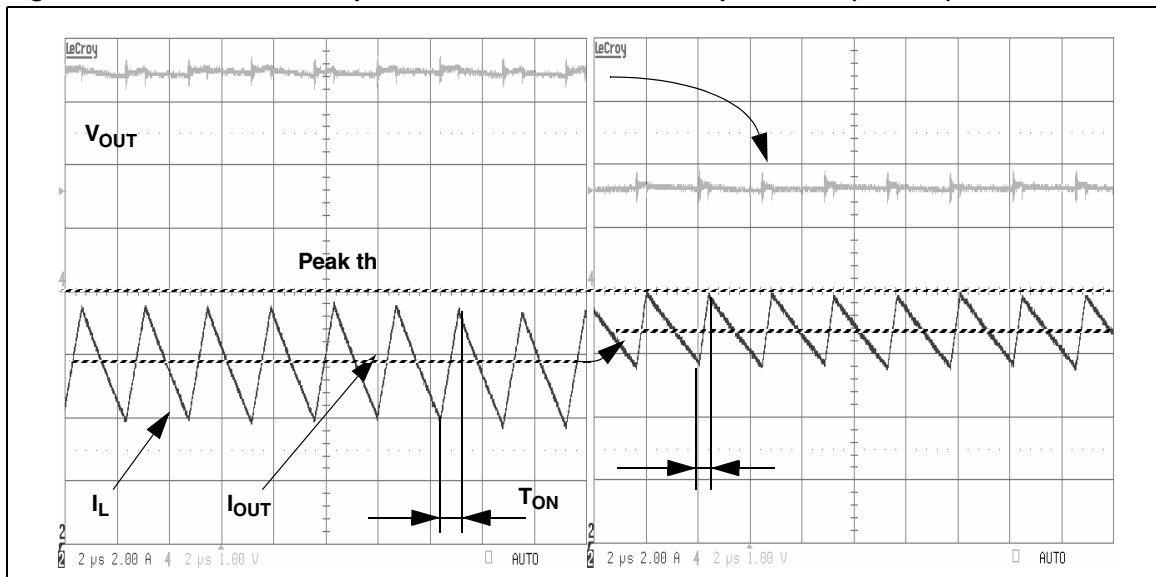
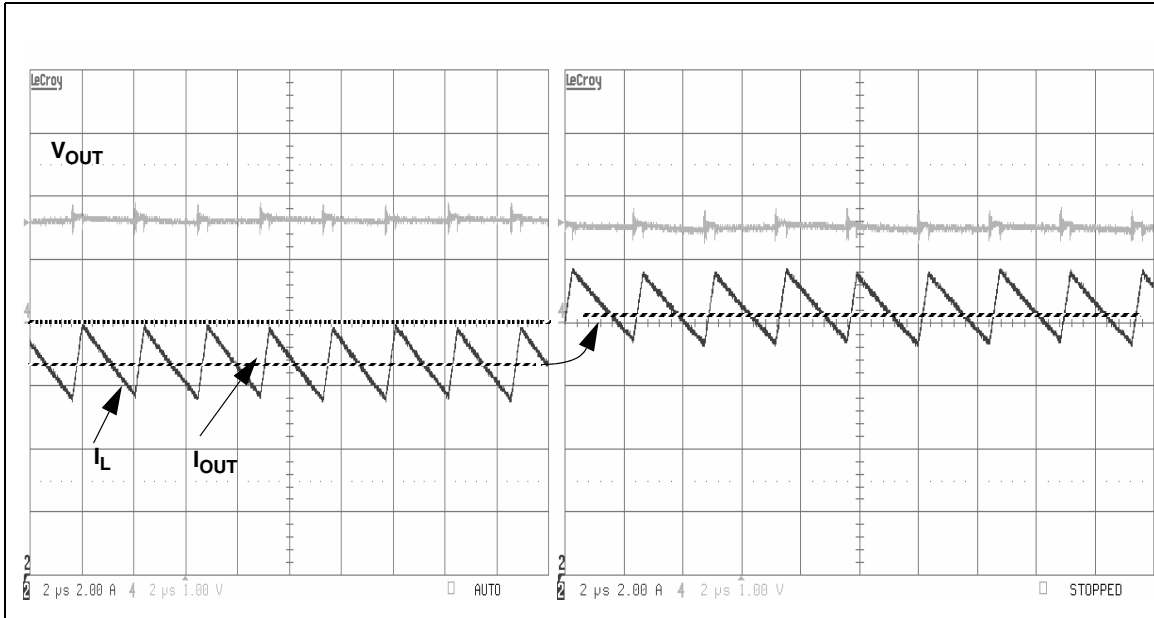

Figure 17. shows the intervention of the peak OCP: the high-side MOSFET(s) is turned-off when the current exceeds the OCP threshold. In this way the duty-cycle is reduced, the  $V_{OUT}$  is reduced and so the maximum current can be fixed even if the output current is escalating.

Figure 18. shows the limit of this protection: the on-time can be reduced only to the masking time and, if the output current continues to increase, the maximum current can increase too. Notice how the  $V_{out}$  remains constant even if the output current increases because the on-time cannot be reduced anymore.

Figure 18. Peak OCP in case of heavy overcurrent (L6730D).



If the current is higher than the valley OCP threshold during the off-time, the high-side MOSFET(s) will not be turned-on. In this way the maximum current can be limited (Figure 19).

Figure 19. Valley OCP (L6730D).

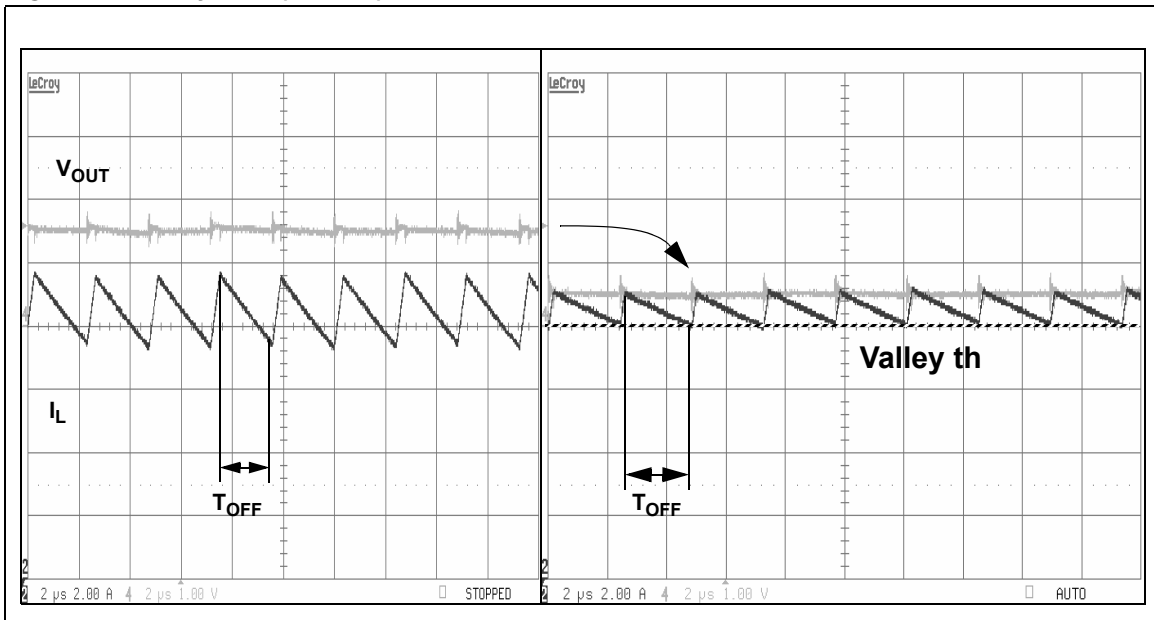



During the constant-current-protection if the  $V_{out}$  becomes lower than 80% of the programmed value an UV (under-voltage) is detected and the device enters in HICCUP mode. The under-voltage-lock-out (UVLO) is adjustable by the multifunction pin (see [Chapter 5.10 on page 25](#)). It's possible to set two different thresholds:

- 4.2V for 5V Bus
- 8.6V for 12V Bus

Working with a 12V BUS, setting the UVLO at 8.6V can be very helpful to limit the input current in case of BUS fall.

## 5.9 Adjustable masking time

By connecting the masking-time pin to  $V_{CCDR}$  or GND it is possible to select two different values for the peak -current-protection leading edge blanking time. This is useful to avoid any false OCP trigger due to spikes and oscillations generated at the turn-on of the high-side MOSFET(s). The amount of this noise depends a lot on the layout, MOSFETs, free-wheeling diode, switched current and input voltage. In case of good layout and medium current, the minimum masking time can be chosen, while in case of higher noise, it's better to select to maximum one. Connecting Tmask pin to  $V_{CCDR}$  the masking time is about 400ns while connecting it to GND the resulting masking time is about 260ns.

## 5.10 Multifunction pin (S/O/U L6730C) (CC/O/U L6730D)

With this pin it is possible:

- To enable-disable the sink-mode-current capability (L6730C) or the constant current protection (L6730D) at the end of the soft-start;
- To enable-disable the latch-mode for the OVP;
- To set the UVLO threshold for 5V BUS and 12V BUS.

[Table 6](#) shows how to set the different options through an external resistor divider:

**Figure 20. External resistor**

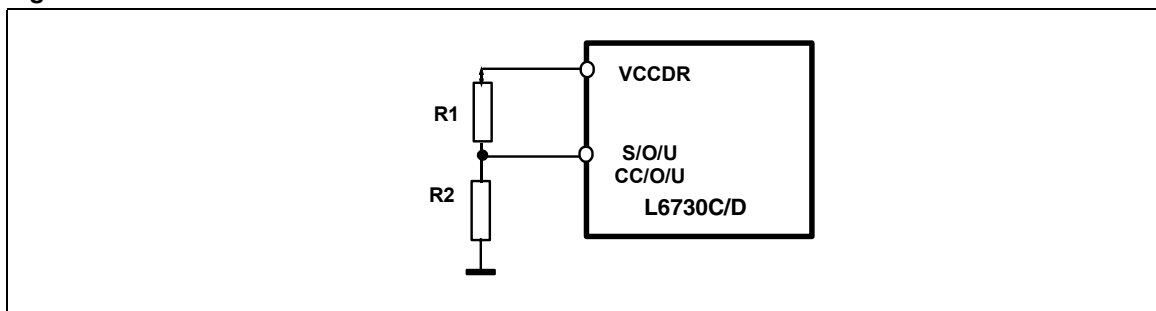
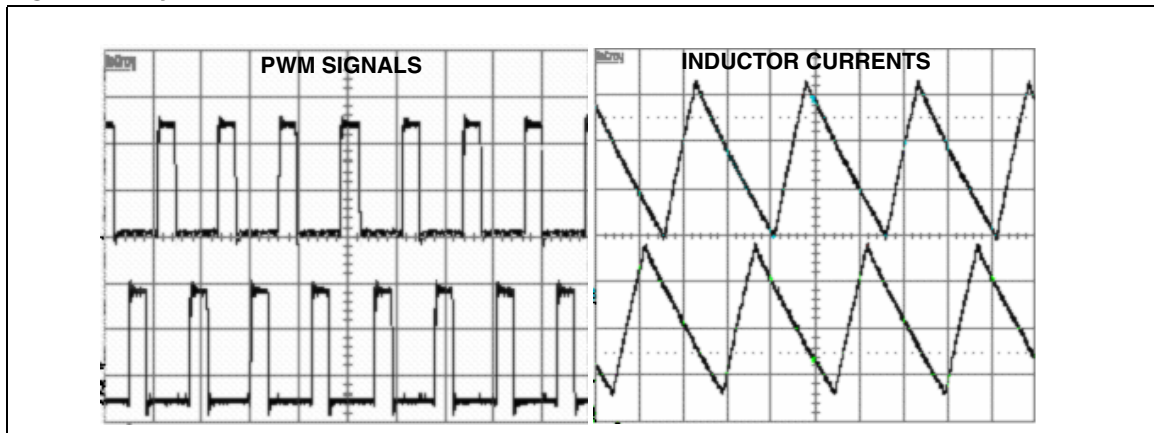

**Table 6. S/O/U pin; CC/O/U pin**

R1	R2	$V_{SOU}/V_{CCDR}$	UVLO	OVP	SINK CC
N.C	0Ω	0	5V BUS	Not Latched	Not
11KΩ	2.7KΩ	0.2	5V BUS	Not Latched	Yes
6.2KΩ	2.7KΩ	0.3	5V BUS	Latched	Not
4.3KΩ	2.7KΩ	0.4	5V BUS	Latched	Yes
2.7KΩ	2.7KΩ	0.5	12V BUS	Not Latched	Not
1.8KΩ	2.7KΩ	0.6	12V BUS	Not Latched	Yes
1.2KΩ	2.7KΩ	0.7	12V BUS	Latched	Not
0Ω	N.C	1	12V BUS	Latched	Yes

## 5.11 Synchronization

The presence of many converters on the same board can generate beating frequency noise. To avoid this it is important to make them operate at the same switching frequency. Moreover, a phase shift between different modules helps to minimize the RMS current on the common input capacitors. [Figure 21](#) shows the results of two modules in synchronization. Two or more devices can be synchronized simply connecting together the SYNCH pins. The device with the higher switching frequency will be the Master while the other one will be the Slave. The Slave controller will increase its switching frequency reducing the ramp amplitude proportionally and then the modulator gain will be increased.

**Figure 21. Synchronization.**

To avoid a huge variation of the modulator gain, the best way to synchronize two or more devices is to make them work at the same switching frequency and, in any case, the switching frequencies can differ for a maximum of 50% of the lowest one. If, during synchronization between two (or more) L6730, it's important to know in advance which the master is, it's timely to set its switching frequency at least 15% higher than the slave. Using an external clock signal ( $f_{EXT}$ ) to synchronize one or more devices that are working at a different switching frequency ( $f_{SW}$ ) it is recommended to follow the below formula:

$$f_{SW} \leq f_{EXT} \leq 1,3 \cdot f_{SW}$$

The phase shift between master and slaves is approximately done 180°.

## 5.12 Thermal shutdown

When the junction temperature reaches  $150^{\circ}\text{C} \pm 10^{\circ}\text{C}$  the device enters in thermal shutdown. Both MOSFETs are turned OFF and the soft-start capacitor is rapidly discharged with an internal switch. The device does not restart until the junction temperature goes down to  $120^{\circ}\text{C}$  and, in any case, until the voltage at the soft-start pin reaches 500mV.

## 5.13 Minimum on-time ( $T_{\text{ON, MIN}}$ )

The device can manage minimum on-times lower than 100ns. This feature comes from the control topology and from the particular over-current-protection system of the L6730C - L6730D. In fact, in a voltage mode controller the current has not to be sensed to perform the regulation and, in the case of L6730C - L6730D, neither for the over-current protection, given that during the off-time the valley-current-protection can operate. The first advantage related to this feature is the possibility to realize extremely low conversion ratios. *Figure 22* shows a conversion from 14V to 0.5V at 820KHz with a  $T_{\text{ON}}$  of about 50ns. The on-time is limited by the turn-on and turn-off times of the MOSFETs.

Figure 22. 14V -> 0.5V@820KHz, 5A

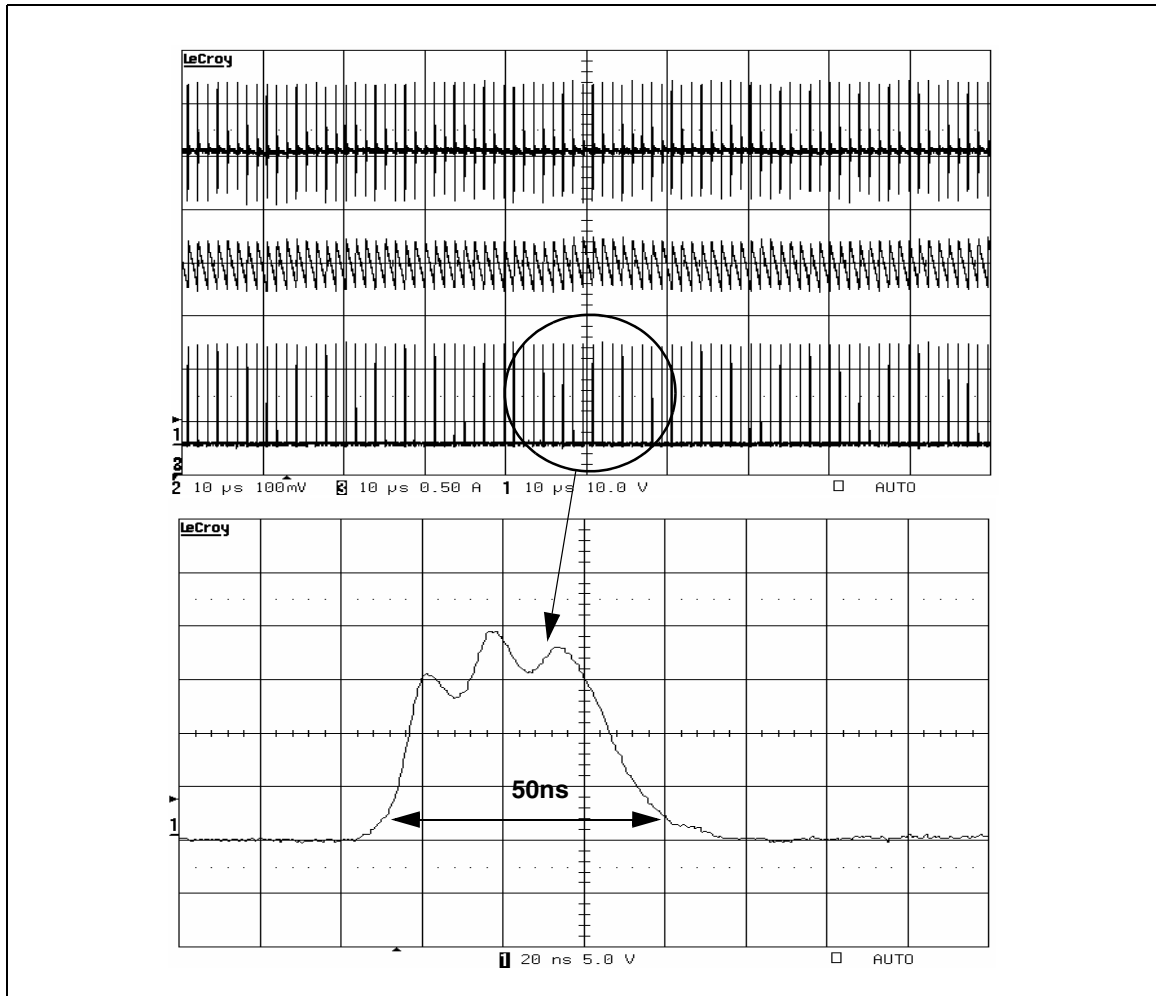

## 5.14 Bootstrap anti-discharging system

This built-in system avoids that the voltage across the bootstrap capacitor becomes less than 3.3V. An internal comparator senses the voltage across the external bootstrap capacitor keeping it charged, eventually turning-on the low-side MOSFET for approximately 200ns. If the bootstrap capacitor is not enough charged the high-side MOSFET cannot be effectively turned-on and it will present a higher  $R_{DS(on)}$ . In some cases the OCP can be also triggered. It's possible to mention at least two application conditions during which the bootstrap capacitor can be discharged:

### 5.14.1 Fan's power supply

In many applications the FAN is a DC MOTOR driven by a voltage-mode DC/DC converter. Often only the speed of the MOTOR is controlled by varying the voltage applied to the input terminal and there's no control on the torque because the current is not directly controlled. Obviously the current has to be limited in case of overload or short-circuit but without stopping the MOTOR. With the L6730D the current can be limited without shutting down the system because a constant-current-protection is provided. In order to vary the MOTOR speed the output voltage of the converter must be varied. Both L6730C and L6730D have a dedicated pin called EAREF (see the related section) that allows providing an external reference to the non-inverting input of the error-amplifier.

In these applications the duty cycle depends on the MOTOR's speed and sometimes 100% has to be set in order to go at the maximum speed. Unfortunately in these conditions the bootstrap capacitor can not be recharged and the system cannot work properly. Some PWM controller limits the maximum duty-cycle to 80-90% in order to keep the bootstrap cap charged but this make worse the performance during the load transient. Thanks to the "bootstrap anti-discharging system" the L6730X can work at 100% without any problem. The following picture shows the device behaviour when input voltage is 5V and 100% is set by the external reference.

Figure 23. 100% duty cycle operation

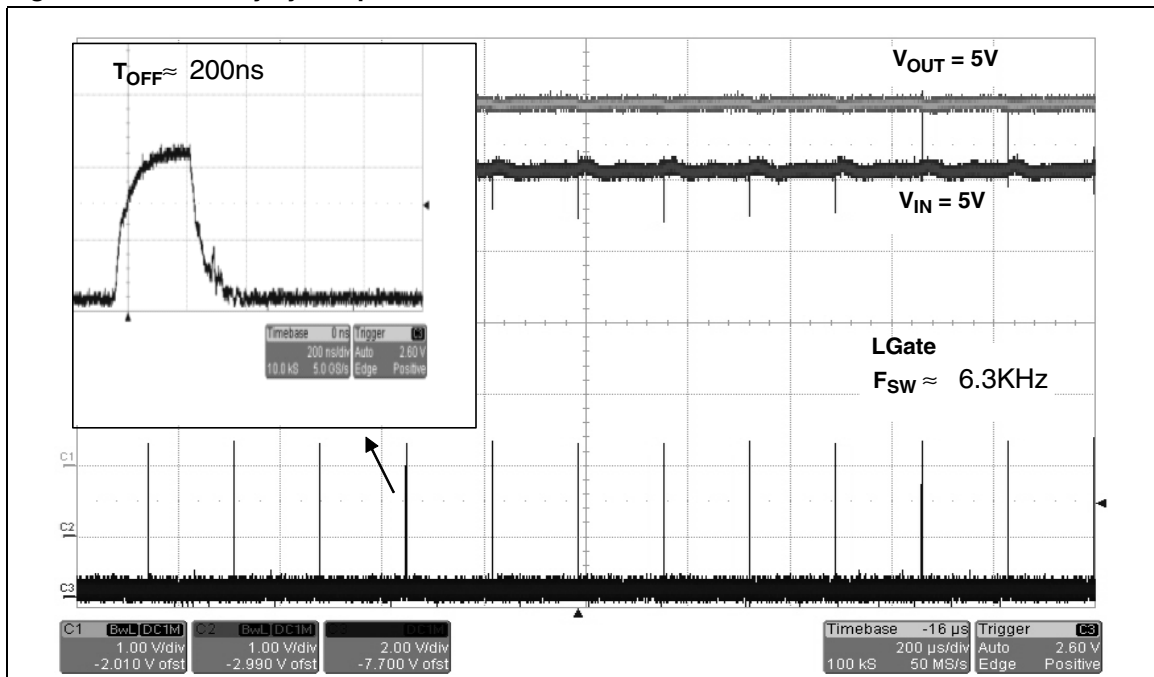

### 5.14.2 No-sink at zero current operation

The L6730C can work in no-sink mode. If output current is zero the converter skip some pulses and works with a lower switching frequency. Between two pulses can pass a relatively long time (say 200-300 $\mu$ s) during which there's no switching activity and the current into the inductor is zero. In this condition the phase node is at the output voltage and in some cases this is not enough to keep the bootstrap cap charged. For example, if  $V_{out}$  is 3.3V the voltage across the bootstrap cap is only 1.7V. The high-side MOSFET cannot be effectively turned-on and the regulation can be lost. Thanks to the "bootstrap anti-discharging system" the bootstrap cap is always kept charged. The following picture shows the behaviour of the device in the following conditions: 12V@3.3V@0A.

Figure 24. 12V -> 3.3V@0A in no-sink

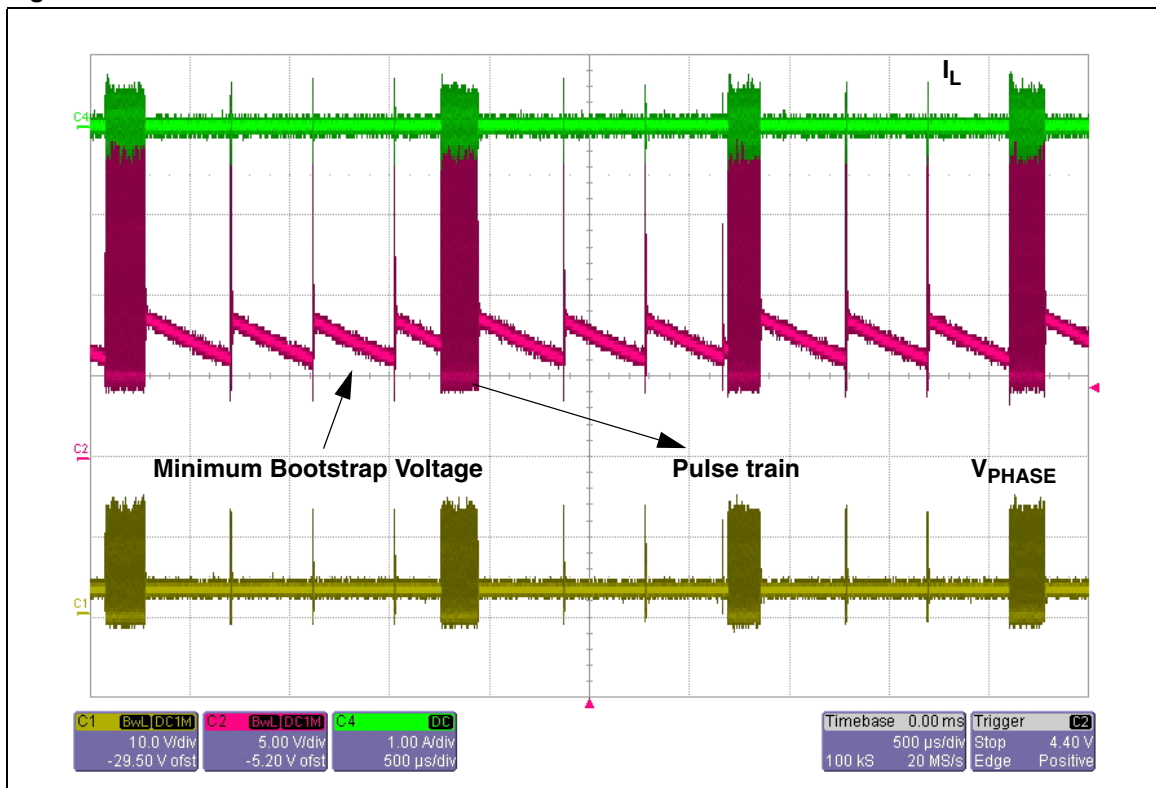

It can be observed that between two pulses trains the low-side is turned-on in order to keep the bootstrap cap charged.

## 6 Application details

### 6.1 Inductor design

The inductance value is defined by a compromise between the transient response time, the efficiency, the cost and the size. The inductor has to be calculated to maintain the ripple current ( $\Delta I_L$ ) between 20% and 30% of the maximum output current. The inductance value can be calculated with the following relationship:

$$L \cong \frac{V_{in} - V_{out}}{F_{sw} \cdot \Delta I_L} \cdot \frac{V_{out}}{V_{in}} \quad (6)$$

Where  $F_{SW}$  is the switching frequency,  $V_{IN}$  is the input voltage and  $V_{OUT}$  is the output voltage. [Figure 25](#) shows the ripple current vs. the output voltage for different values of the inductor, with  $V_{in} = 5V$  and  $V_{in} = 12V$  at a switching frequency of 400KHz.

**Figure 25. Inductor current ripple.**

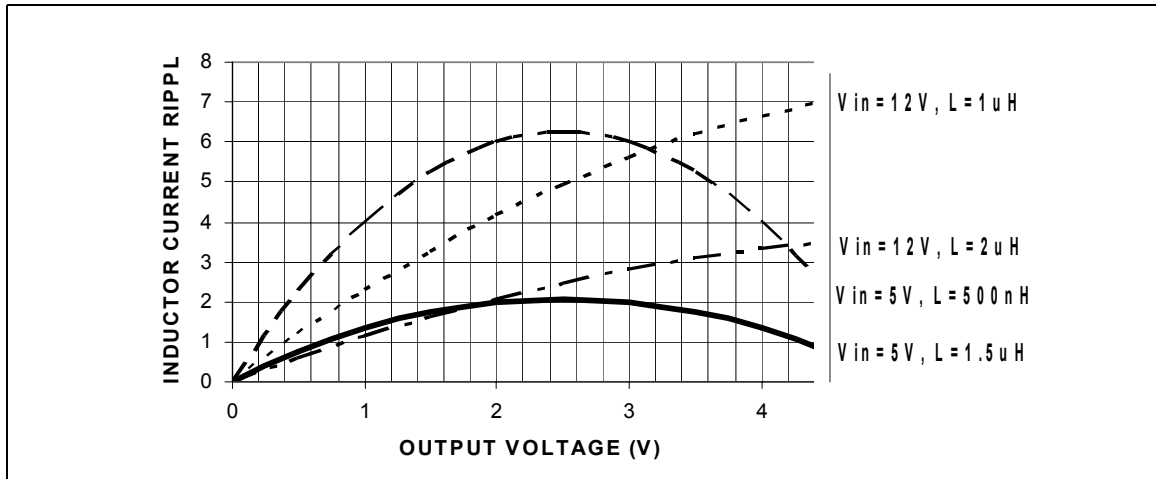

Increasing the value of the inductance reduces the current ripple but, at the same time, increases the converter response time to a load transient. If the compensation network is well designed, during a load transient the device is able to set the duty cycle to 100% or to 0%. When one of these conditions is reached, the response time is limited by the time required to change the inductor current. During this time the output current is supplied by the output capacitors. Minimizing the response time can minimize the output capacitor size.

## 6.2 Output capacitors

The output capacitors are basic components for the fast transient response of the power supply. They depend on the output voltage ripple requirements, as well as any output voltage deviation requirement during a load transient. During a load transient, the output capacitors supply the current to the load or absorb the current stored into the inductor until the converter reacts. In fact, even if the controller recognizes immediately the load transient and sets the duty cycle at 100% or 0%, the current slope is limited by the inductor value. The output voltage has a first drop due to the current variation inside the capacitor (neglecting the effect of the ESL):

$$\Delta V_{out_{ESR}} = \Delta I_{out} \cdot ESR \quad (7)$$

Moreover, there is an additional drop due to the effective capacitor discharge or charge that is given by the following formulas:

$$\Delta V_{out_{COUT}} = \frac{\Delta I_{out}^2 \cdot L}{2 \cdot C_{out} \cdot (V_{in, \min} \cdot D_{\max} - V_{out})} \quad (8)$$

$$\Delta V_{out_{COUT}} = \frac{\Delta I_{out}^2 \cdot L}{2 \cdot C_{out} \cdot V_{out}} \quad (9)$$

Formula (8) is valid in case of positive load transient while the formula (9) is valid in case of negative load transient.  $D_{MAX}$  is the maximum duty cycle value that in the L6730C - L6730D is 100%. For a given inductor value, minimum input voltage, output voltage and maximum load transient, a maximum ESR and a minimum  $C_{OUT}$  value can be set. The ESR and  $C_{OUT}$  values also affect the static output voltage ripple. In the worst case the output voltage ripple can be calculated with the following formula:

$$\Delta V_{out} = \Delta I_L \cdot \left( ESR + \frac{1}{8 \cdot C_{out} \cdot F_{sw}} \right) \quad (10)$$

Usually the voltage drop due to the ESR is the biggest one while the drop due to the capacitor discharge is almost negligible.

## 6.3 Input capacitors

The input capacitors have to sustain the RMS current flowing through them, that is:

$$I_{rms} = I_{out} \cdot \sqrt{D \cdot (1 - D)} \quad (11)$$

Where D is the duty cycle. The equation reaches its maximum value,  $I_{OUT}/2$  with  $D = 0.5$ . The losses in worst case are:

$$P = ESR \cdot (0.5 \cdot I_{out})^2 \quad (12)$$

## 6.4 Compensation network

The loop is based on a voltage mode control ([Figure 26](#)). The output voltage is regulated to the internal/external reference voltage and scaled by the external resistor divider. The error amplifier output  $V_{COMP}$  is then compared with the oscillator triangular wave to provide a pulse-width modulated (PWM) with an amplitude of  $V_{IN}$  at the PHASE node. This waveform is filtered by the output filter. The modulator transfer function is the small signal transfer function of  $V_{OUT}/V_{COMP}$ . This function has a double pole at frequency  $F_{LC}$  depending on the L-Cout resonance and a zero at  $F_{ESR}$  depending on the output capacitor's ESR. The DC Gain of the modulator is simply the input voltage  $V_{IN}$  divided by the peak-to-peak oscillator voltage:  $V_{OSC}$ .

**Figure 26. Compensation network**

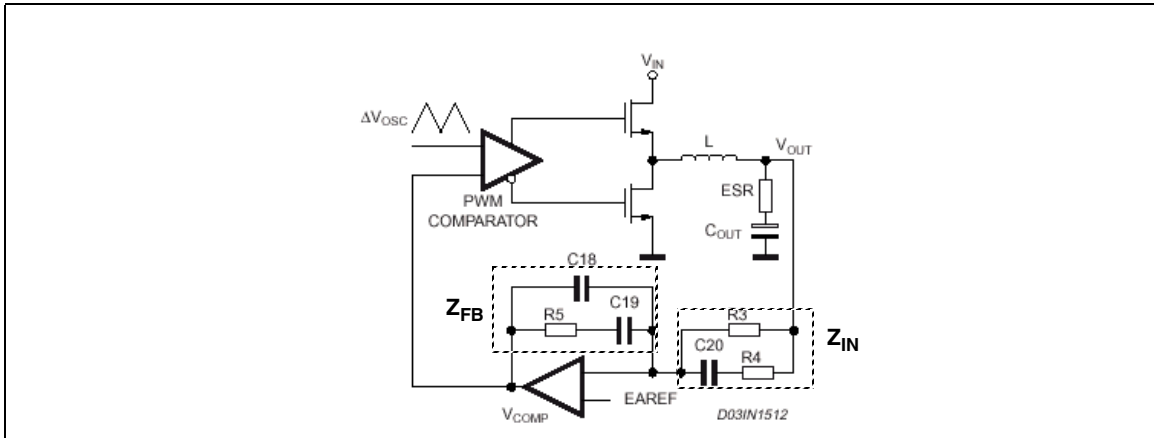

The compensation network consists in the internal error amplifier, the impedance networks  $Z_{IN}$  (R3, R4 and C20) and  $Z_{FB}$  (R5, C18 and C19). The compensation network has to provide a closed loop transfer function with the highest 0dB crossing frequency to have fastest transient response (but always lower than  $f_{SW}/10$ ) and the highest gain in DC conditions to minimize the load regulation error. A stable control loop has a gain crossing the 0dB axis with -20dB/decade slope and a phase margin greater than 45°. To locate poles and zeroes of the compensation networks, the following suggestions may be used:

- Modulator singularity frequencies:

$$\omega_{LC} = \frac{1}{\sqrt{L \cdot C_{out}}} \quad (13) \quad \omega_{ESR} = \frac{1}{ESR \cdot C_{out}} \quad (14)$$

- Compensation network singularity frequencies:

$$\omega_{p1} = \frac{1}{R_5 \cdot \left( \frac{C_{18} \cdot C_{19}}{C_{18} + C_{19}} \right)} \quad (15) \quad \omega_{p2} = \frac{1}{R_4 \cdot C_{20}} \quad (16)$$

$$\omega_{z1} = \frac{1}{R_5 \cdot C_{19}} \quad (17) \quad \omega_{z2} = \frac{1}{C_{20} \cdot (R_3 + R_4)} \quad (18)$$



- Compensation network design:
  - Put the gain  $R_5/R_3$  in order to obtain the desired converter bandwidth

$$\omega_C = \frac{R_5}{R_3} \cdot \frac{V_{in}}{\Delta V_{OSC}} \cdot \omega_{LC} \quad (18)$$

- Place  $\omega_{Z1}$  before the output filter resonance  $\omega_{LC}$ ;
- Place  $\omega_{Z2}$  at the output filter resonance  $\omega_{LC}$ ;
- Place  $\omega_{P1}$  at the output capacitor ESR zero  $\omega_{ESR}$ ;
- Place  $\omega_{P2}$  at one half of the switching frequency;
- Check the loop gain considering the error amplifier open loop gain.

**Figure 27. Asymptotic bode plot of converter's open loop gain**

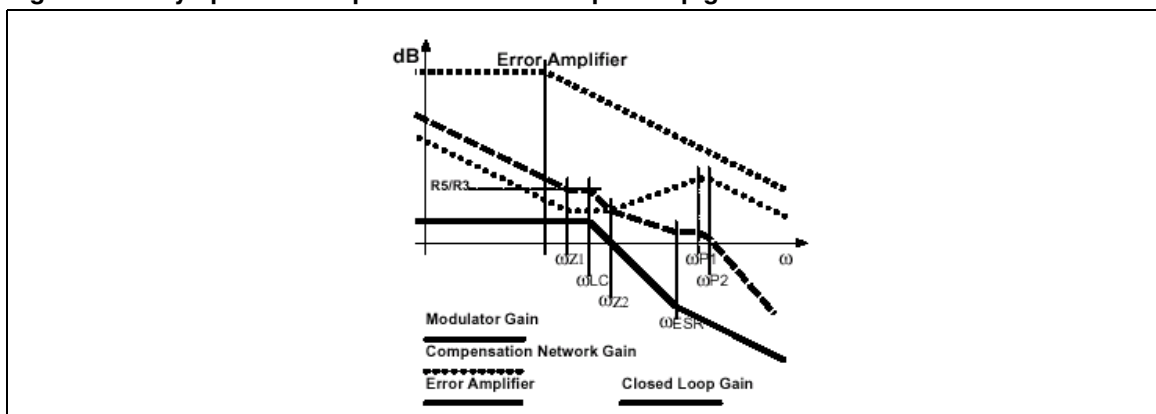

## 6.5 Two quadrant or one quadrant operation mode (L6730C)

After the soft-start phase the L6730C can work in source only (one quadrant operation mode) or in sink/source (two quadrant operation mode), depending on the setting of the multifunction pin (see [Chapter 5.10 on page 25](#)). The choice of one or two quadrant operation mode is related to the application. One quadrant operation mode permits to have a higher efficiency at light load, because the converter works in discontinuous mode (see [Figure 28](#)). Nevertheless in some cases, in order to maintain a constant switching frequency, it's preferable to work in two quadrants, even at light load. In this way the reduction of the switching frequency due to the pulse skipping is avoided. To parallel two or more modules is requested the one quadrant operation in order not to have current sinking between different converters. Finally the two quadrant operation allows faster recovers after negative load transient. For example, let's consider that the load current falls down from  $I_{OUT}$  to 0A with a slew rate sufficiently greater than  $L/V_{OUT}$  (where L is the inductor value). Even considering that the converter reacts instantaneously setting to 0% the duty-cycle, the energy  $\frac{1}{2} * L * I_{OUT}^2$  stored in the inductor will be transferred to the output capacitors, increasing the output voltage. If the converter can sink current this overvoltage can be faster eliminated.

Figure 28. Efficiency in discontinuous-current-mode and continuous-current-mode.

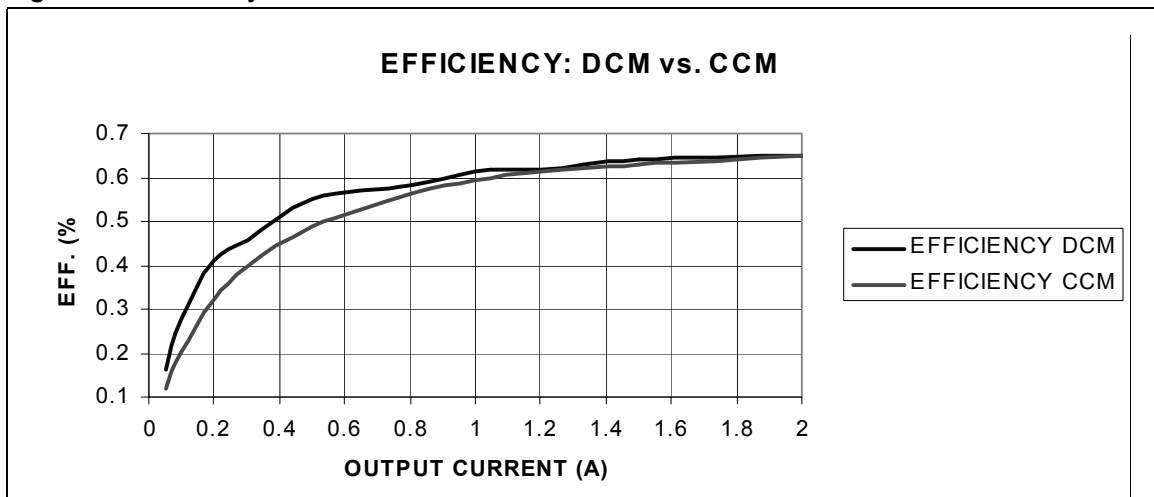

## 7 L6730 Demoboard

### 7.1 Description

L6730 demoboard realizes in a four layer PCB a step-down DC/DC converter and shows the operation of the device in a general purpose application. The input voltage can range from 4.5V to 14V and the output voltage is at 3.3V. The module can deliver an output current in excess of 30A. The switching frequency is set at 400 KHz (controller free-running  $F_{SW}$ ) but it can be increased up to 1MHz. A 7 positions dip-switch allows to select the UVLO threshold (5V or 12V Bus), the OVP intervention mode and the sink-mode current capability.

Figure 29. Demoboard picture.

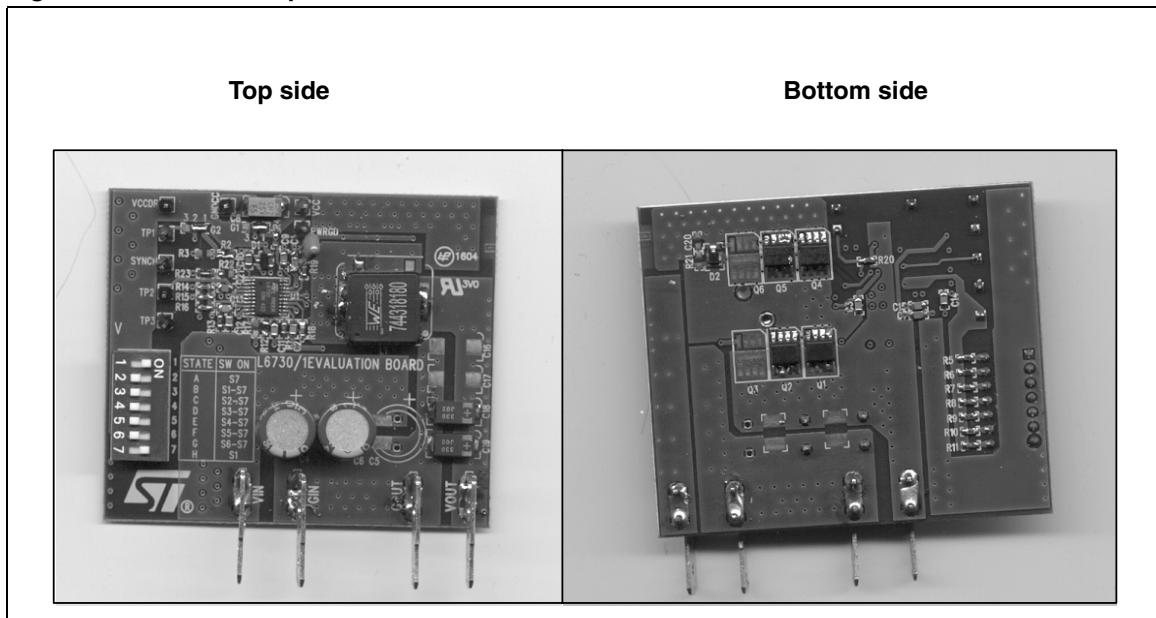

## 7.2 PCB layout

Figure 30. Top layer

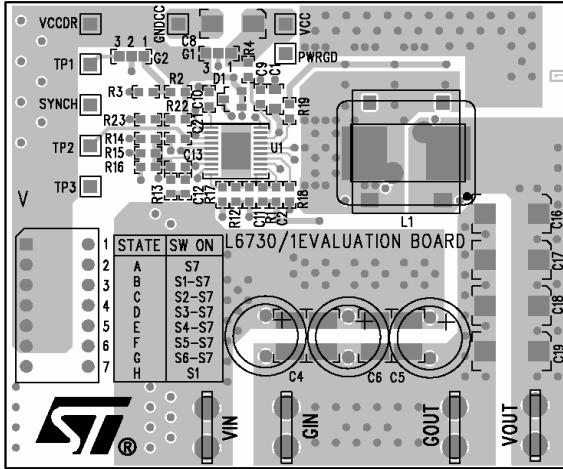

Figure 31. Power ground layer

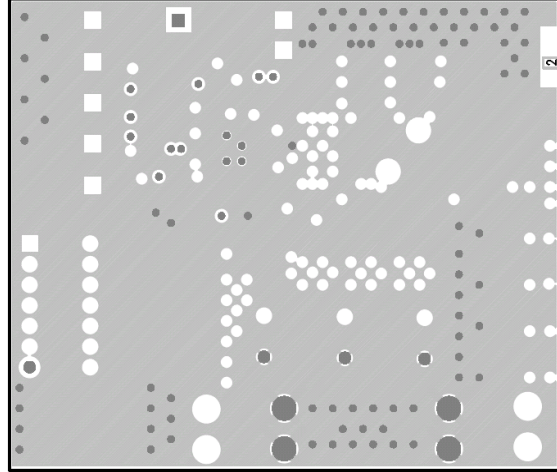

Figure 32. Signal ground layer

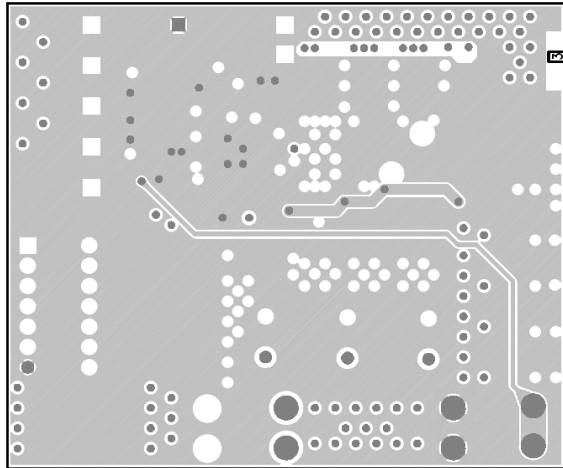

Figure 33. Bottom layer

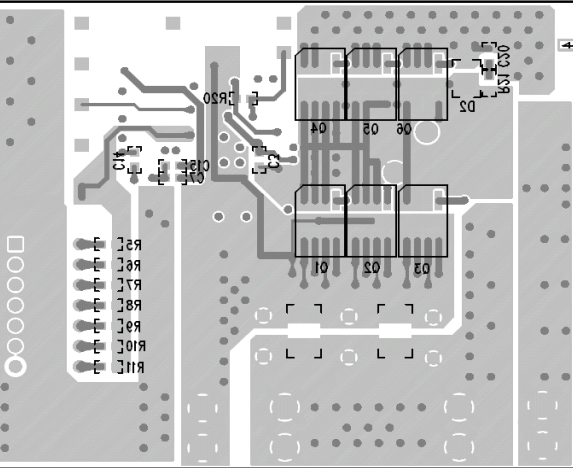

Figure 34. Demoboard schematic

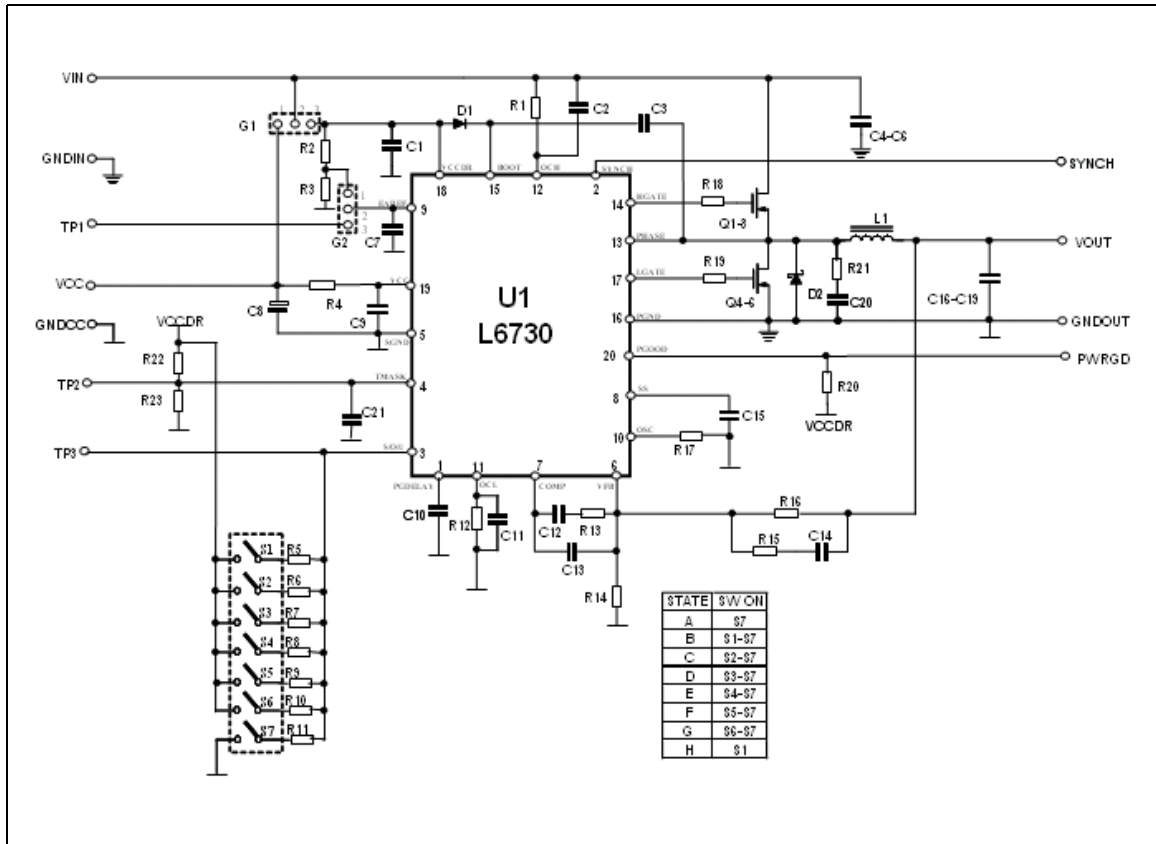

Table 7. Demoboard part list

Reference	Value	Manufacturer	Package	Supplier
R1	820Ω	Neohm	SMD 0603	IFARCAD
R2	0Ω	Neohm	SMD 0603	IFARCAD
R3	N.C.			
R4	10Ω 1% 100mW	Neohm	SMD 0603	IFARCAD
R5	11K 1% 100mW	Neohm	SMD 0603	IFARCAD
R6	6K2 1% 100mW	Neohm	SMD 0603	IFARCAD
R7	4K3 1% 100mW	Neohm	SMD 0603	IFARCAD
R8	2K7 1% 100mW	Neohm	SMD 0603	IFARCAD
R9	1K8 1% 100mW	Neohm	SMD 0603	IFARCAD
R10	1K2 1% 100mW	Neohm	SMD 0603	IFARCAD
R11	2K7 1% 100mW	Neohm	SMD 0603	IFARCAD
R12	1K	Neohm	SMD 0603	IFARCAD

Table 7. Demoboard part list

Reference	Value	Manufacturer	Package	Supplier
R13	2K7 1% 100mW	Neohm	SMD 0603	IFARCAD
R14	1K 1% 100mW	Neohm	SMD 0603	IFARCAD
R15	1K 1% 100mW	Neohm	SMD 0603	IFARCAD
R16	4K7 1% 100mW	Neohm	SMD 0603	IFARCAD
R17	N.C.			
R18	2.2Ω	Neohm	SMD 0603	IFARCAD
R19	2.2Ω	Neohm	SMD 0603	IFARCAD
R20	10K 1% 100mW	Neohm	SMD 0603	IFARCAD
R21	N.C.			
R22	N.C.			
R23	0Ω	Neohm	SMD 0603	IFARCAD
C1	220nF	Kemet	SMD 0603	IFARCAD
C3-C7-C9-C15-C21	100nF	Kemet	SMD 0603	IFARCAD
C2	1nF.	Kemet	SMD 0603	IFARCAD
C4-C6	100uF 20V	OSCON 20SA100M	RADIAL 10X10.5	SANYO
C8	4.7uF 20V	AVX	SMA6032	IFARCAD
C10	10nF	Kemet	SMD 0603	IFARCAD
C11	N.C.			
C12	47nF	Kemet	SMD 0603	IFARCAD
C13	1.5nF	Kemet	SMD 0603	IFARCAD
C14	4.7nF	Kemet	SMD 0603	IFARCAD
C18-C19	330uF 6.3V	POSCAP 6TPB330M	SMD	SANYO
C20	N.C.			
L1	1.8uH	Panasonic	SMD	ST
D1	1N4148	ST	SOT23	IFARCAD
D2	STS1L30M	ST	DO216AA	STMicroelectronics
Q1-Q2	STS12NH3LL	ST	SO8	STMicroelectronics
Q4-Q5	STSJ100NH3LL	ST	SO8	STMicroelectronics
U1	L6730	ST	HTSSOP20	STMicroelectronics
SWITCH	DIP SWITCH 7 POS.			STMicroelectronics

**Table 8. Other inductor manufacturer**

Manufacturer	Series	Inductor Value ( $\mu\text{H}$ )	Saturation Current (A)
WURTH ELEKTRONIC	744318180	1.8	20
SUMIDA	CDEP134-2R7MC-H	2.7	15
EPCOS	HPI_13 T640	1.4	22
TDK	SPM12550T-1R0M220	1	22
TOKO	FDA1254	2.2	14
COILTRONICS	HCF1305-1R0	1.15	22
	HC5-1R0	1.3	27

**Table 9. Other capacitor manufacturer**

Manufacturer	Series	Capacitor value( $\mu\text{F}$ )	Rated voltage (V)
TDK	C4532X5R1E156M	15	25
	C3225X5R0J107M	100	6.3
NIPPON CHEMI-CON	25PS100MJ12	100	25
PANASONIC	ECJ4YB0J107M	100	6.3

## 8 I/O Description

Figure 35. Demoboard

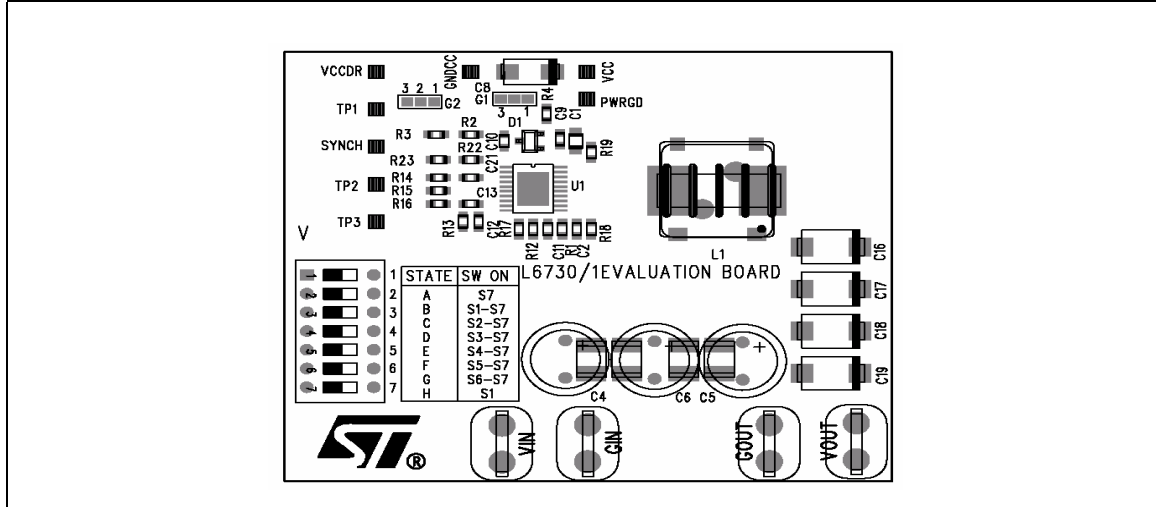

Table 10. I/O Functions

Symbol	Function
Input ( $V_{IN}$ - $G_{IN}$ )	The input voltage can range from 1.8V to 14V. If the input voltage is between 4.5V and 14V it can supply also the device (through the $V_{CC}$ pin) and in this case the pin 1 and 2 of the jumper G1 must be connected together.
Output ( $V_{OUT}$ - $G_{OUT}$ )	The output voltage is fixed at 3.3V but it can be changed by replacing the resistor R14 of the output resistor divider: $V_o = V_{REF} \cdot \left(1 + \frac{R_{16}}{R_{14}}\right)$ The over-current-protection limit is set at 15A but it can be changed by replacing the resistors R1 and R12 (see OCL and OCH pin in <a href="#">Table 3: Pins connection</a> ).
$V_{CC}$ - $GND_{CC}$	Using the input voltage to supply the controller no power is required at this input. However the controller can be supplied separately from the power stage through the $V_{CC}$ input (4.5-14V) and, in this case, jumper G1 must be left open.
$V_{CCDR}$	An internal LDO provides the power into the device. The input of this stage is the $V_{CC}$ pin and the output (5V) is the $V_{ccdr}$ pin. The LDO can be bypassed, providing directly a 5V voltage from $V_{CCDR}$ and $Gndcc$ . In this case the pins 1 and 3 of the jumper G1 must be shorted.
TP1	This pin can be used as an input or as a test point. If all the jumper G2 pins are shorted, TP1 can be used as a test point of the voltage at the EAREF pin. If the pins 2 and 3 of G2 are connected together, TP1 can be used as an input to provide an external reference for the internal error amplifier (see section 4.3. Internal and external references).
TP2	This test point is connected to the Tmask pin (see <a href="#">Table 3: Pins connection</a> ).
TP3	This test point is connected to the S/O/U pin (see <a href="#">Chapter 5.10 on page 25</a> ).



**Table 10. I/O Functions**

SYNCH	This pin is connected to the synch pin of the controller (see <a href="#">Chapter 5.11 on page 26</a> ).
PWRGD	This pin is connected to the PGOOD pin of the controller.
DIP SWITCH	Different positions of the dip switch correspond to different settings of the multifunction pin (S/O/U) (CC/O/U).

**Table 11. Dip switch**

UVLO	OVP	SINK CC	V <sub>sou</sub> /V <sub>CCDR</sub>	DIP SWITCH	STATE
5V	Not Latched	Not	0	S7	A
5V	Not Latched	Yes	0.2	S1-S7	B
5V	Latched	Not	0.3	S2-S7	C
5V	Latched	Yes	0.4	S3-S7	D
12V	Not Latched	Not	0.5	S4-S7	E
12V	Not Latched	Yes	0.6	S5-S7	F
12V	Latched	Not	0.7	S6-S7	G
12V	Latched	Yes	1	S1	H

## 9 Efficiency

The following figures show the demoboard efficiency versus load current for different values of input voltage and switching frequency:

Figure 36. Demoboard efficiency 400KHz

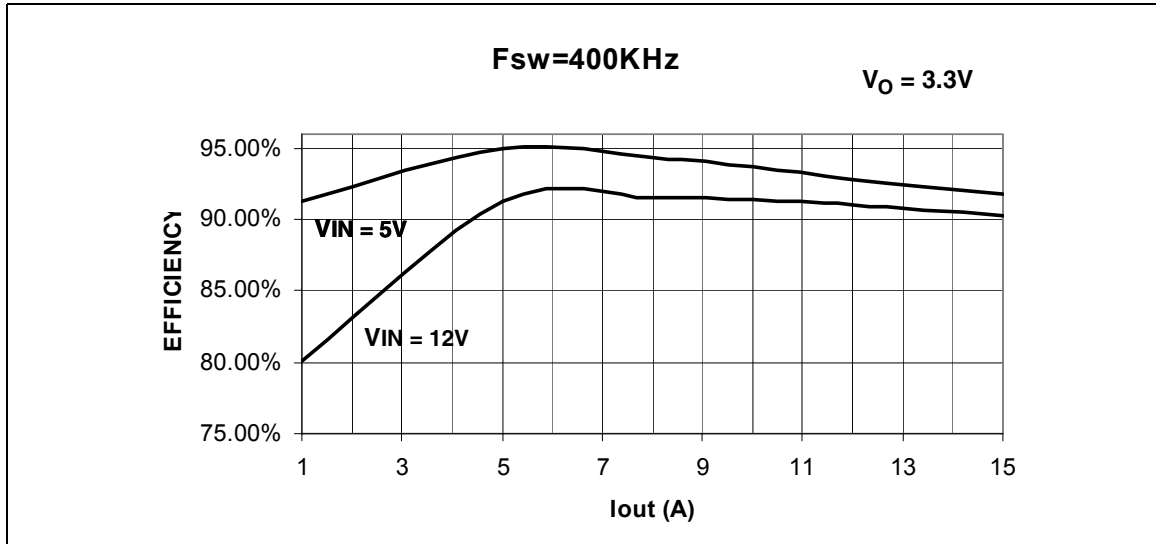

Figure 37. Demoboard efficiency 645KHz

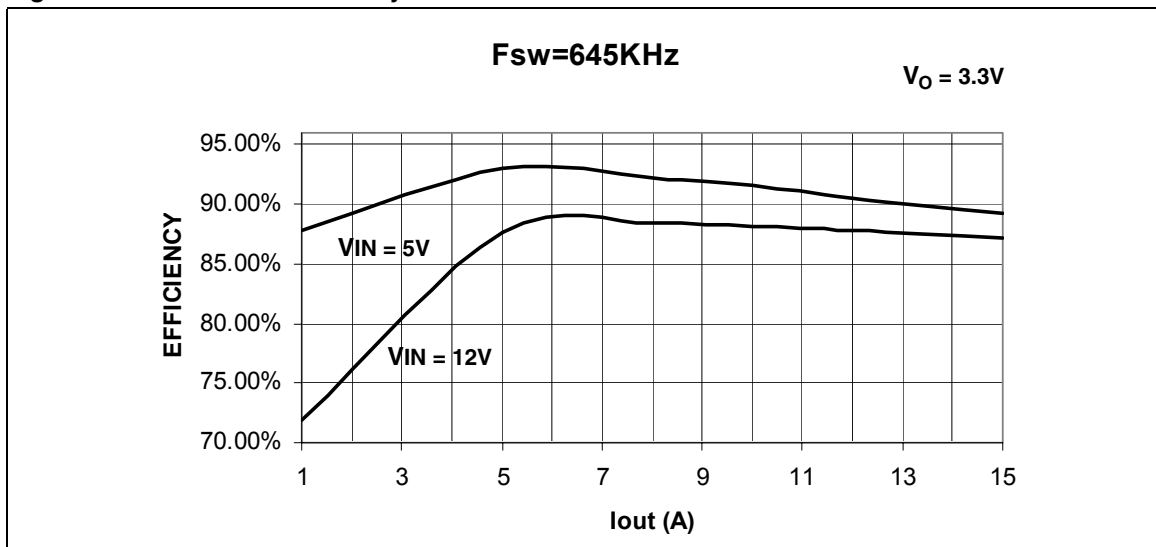

Figure 38. Demoboard efficiency 1MHz

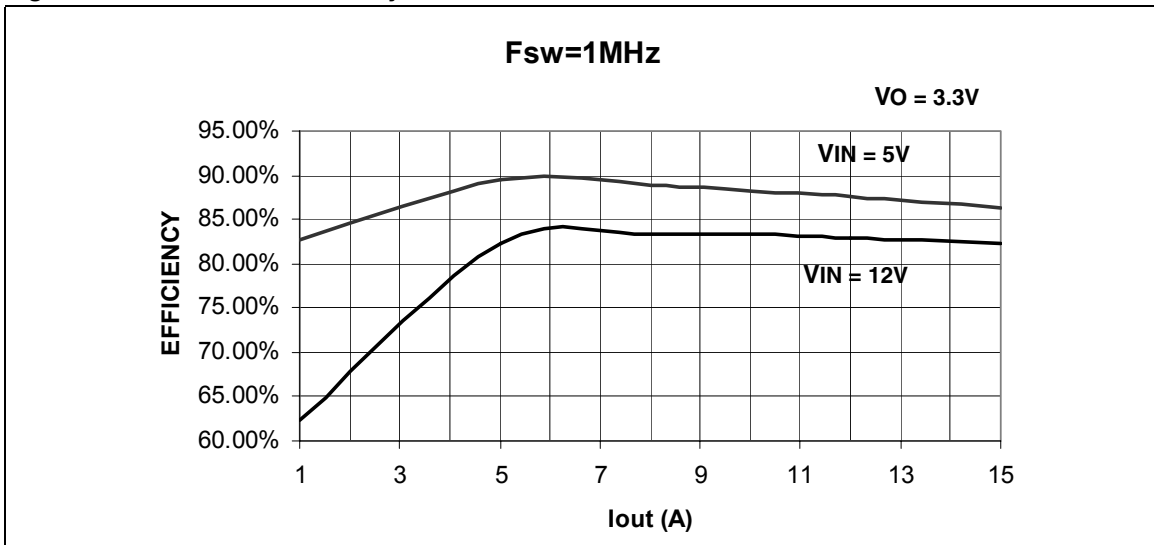
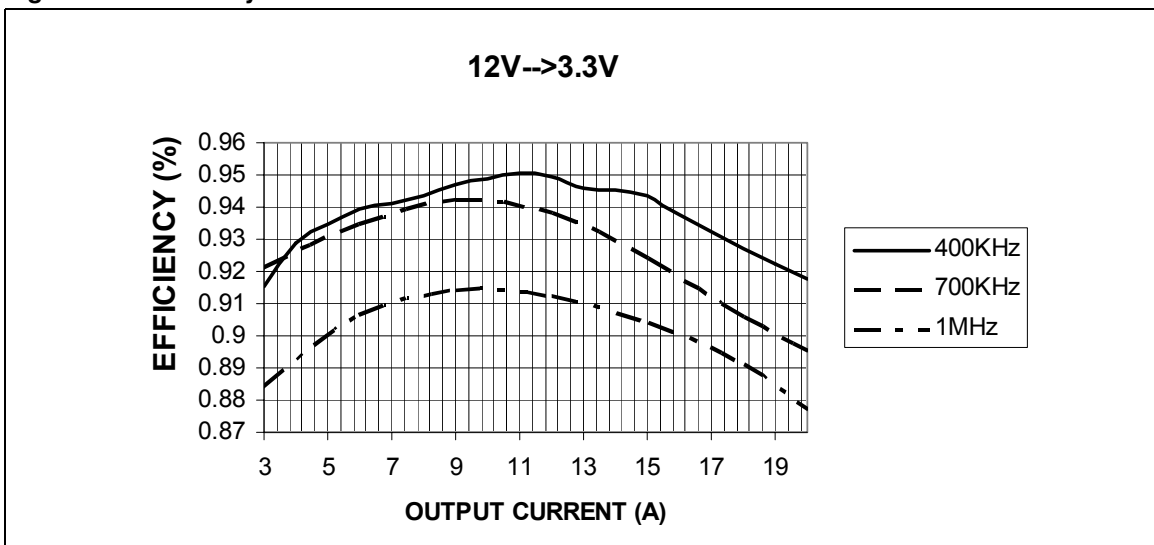

Figure 39. Efficiency with 2xSTS12NH3LL+2XSTSJ100NH3LL



## 10 POL Demoboard

### 10.1 Description

A compact demoboard has been realized to manage currents in the range of 10-15A. [Figure 36](#) shows the schematic and [Table 9](#) the part list. Multi-layer-ceramic-capacitors (MLCCs) have been used on the input and the output in order to reduce the overall size.

**Figure 40. Pol demoboard schematic.**

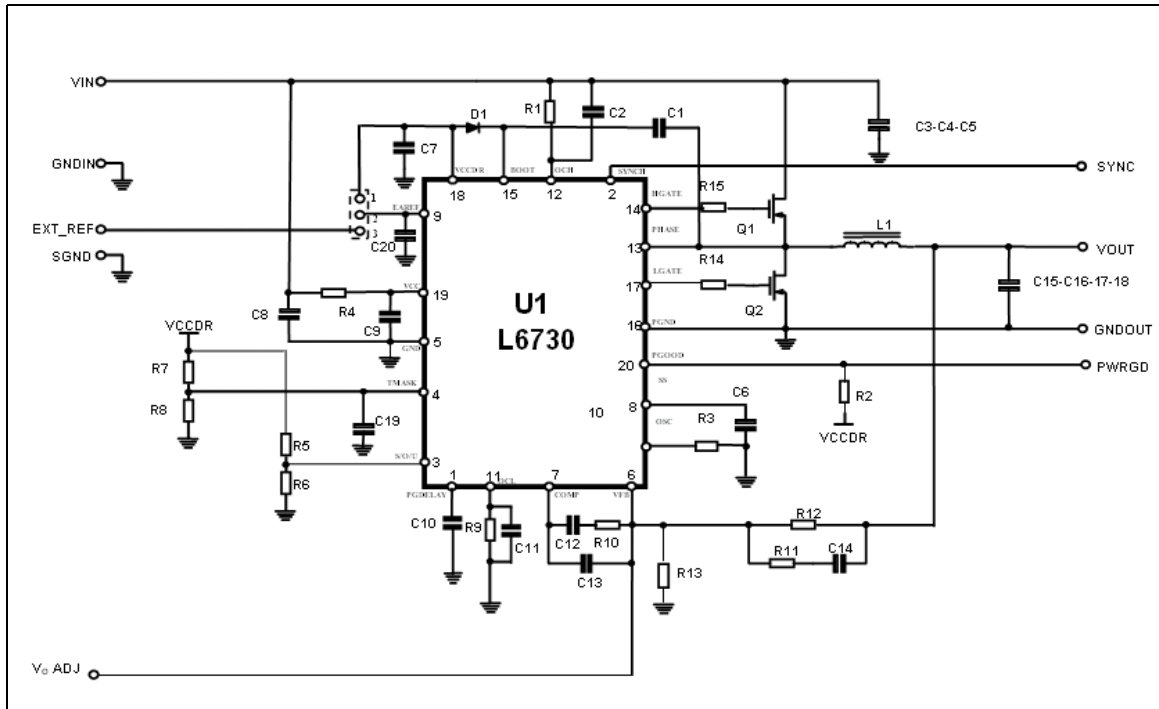

**Table 12. Pol demoboard part list.**

Reference	Value	Manufacturer	Package	Supplier
R1	1K8Ω	Neohm	SMD 0603	IFARCAD
R2	10KΩ	Neohm	SMD 0603	IFARCAD
R3	N.C.			
R4	10Ω	Neohm	SMD 0603	IFARCAD
R5	11K 1% 100mW	Neohm	SMD 0603	IFARCAD
R6	2K7 1% 100mW	Neohm	SMD 0603	IFARCAD
R7	N.C.	Neohm	SMD 0603	IFARCAD
R8	0Ω	Neohm	SMD 0603	IFARCAD
R9	3K 1% 100mW	Neohm	SMD 0603	IFARCAD
R10	4K7 1% 100mW	Neohm	SMD 0603	IFARCAD

Table 12. Pol demoboard part list.

R11	15Ω 1% 100mW	Neohm	SMD 0603	IFARCAD
R12	4K7 1% 100mW	Neohm	SMD 0603	IFARCAD
R13	1K 1% 100mW	Neohm	SMD 0603	IFARCAD
R14	2.2Ω	Neohm	SMD 0603	IFARCAD
R15	2.2Ω	Neohm	SMD 0603	IFARCAD
C1-C7	220nF	Kemet	SMD 0603	IFARCAD
C6- C19-C20-C9	100nF	Kemet	SMD 0603	IFARCAD
C2	1nF	Kemet	SMD 0603	IFARCAD
C11	N.C.			
C12	68nF	Kemet	SMD 0603	IFARCAD
C13	220pF	Kemet	SMD0603	IFARCAD
C8	4.7uF 20V	AVX	SMA6032	IFARCAD
C14	6.8nF	Kemet	SMD 0603	IFARCAD
C3-C4-C5	15uF	TDK MLC C4532X5R1E156M	SMD1812	IFARCAD
C15-C16-C17-C18	100uF	PANASONIC MLC P/N ECJ4YBOJ107M	SMD 1210	IFARCAD
L1	1.8uH	Panasonic	SMD	ST
D1	STS1L30M	ST	DO216AA	ST
Q1	STS12NH3LL	ST	POWER SO8	ST
Q2	STSJ100NH3LL	ST	POWER SO8	ST
U1	L6730	ST	HTSSOP20	ST

Figure 41. Pol Demoboard efficiency

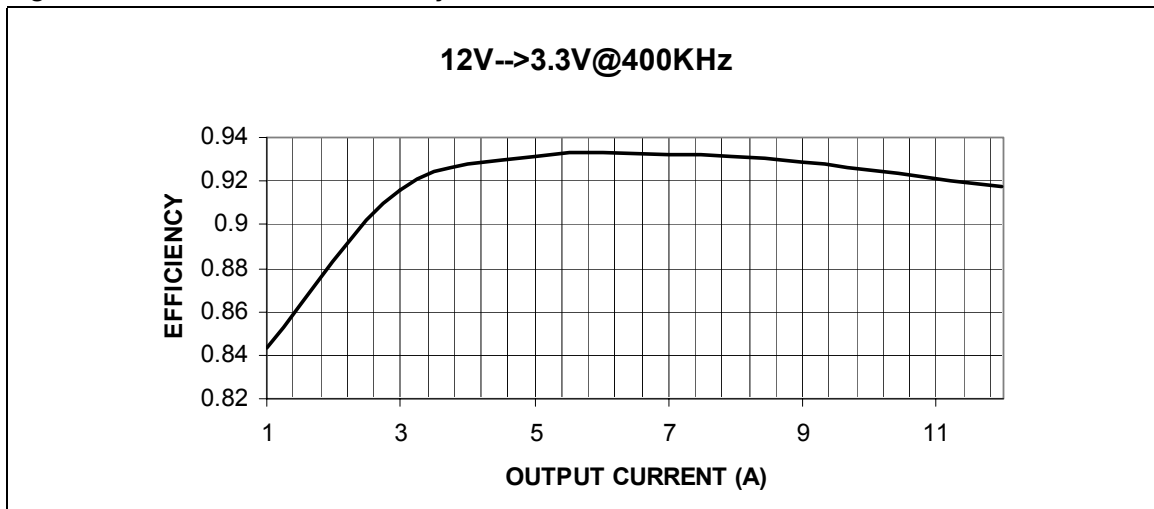

## 11 Package mechanical data

In order to meet environmental requirements, ST offers these devices in ECOPACK® packages. These packages have a Lead-free second level interconnect . The category of second Level Interconnect is marked on the package and on the inner box label, in compliance with JEDEC Standard JESD97. The maximum ratings related to soldering conditions are also marked on the inner box label. ECOPACK is an ST trademark. ECOPACK specifications are available at: [www.st.com](http://www.st.com).

Table 13. HTSSOP20 mechanical data

DIM.	mm			inch		
	Min	Typ	Max	Min	Typ	Max
A			1.200			0.047
A1			0.150			0.006
A2	0.800	1.000	1.050	0.031	0.039	0.041
b	0.190		0.300	0.007		0.012
c	0.090		0.200	0.003		0.008
D <sup>(1)</sup>	6.400	6.500	6.600	0.252	0.256	0.260
D1 <sup>(3)</sup>	2.200			0.087		
E	6.200	6.400	6.600	0.244	0.252	0.260
E1 <sup>(2)</sup>	4.300	4.400	4.500	0.170	0.173	0.177
E2 <sup>(3)</sup>	1.500			0.059		
e		0.650			0.025	
L	0.450	0.600	0.750	0.018	0.024	0.030
L1		1.000			0.039	
k	0° min., 8° max.					
aaa			0.100			0.004

1. Dimension "D" does not include mold flash, protrusions or gate burrs. Mold flash, protrusions or gate burrs shall not exceed 0.15mm per side.
2. Dimension "E1" does not include interlead flash or protrusions. Intelead flash or protrusions shall not exceed 0.25mm per side.
3. The size of exposed pad is variable depending of leadframe design pad size. End user should verify "D1" and "E2" dimensions for each device application.

Figure 42. Package dimensions

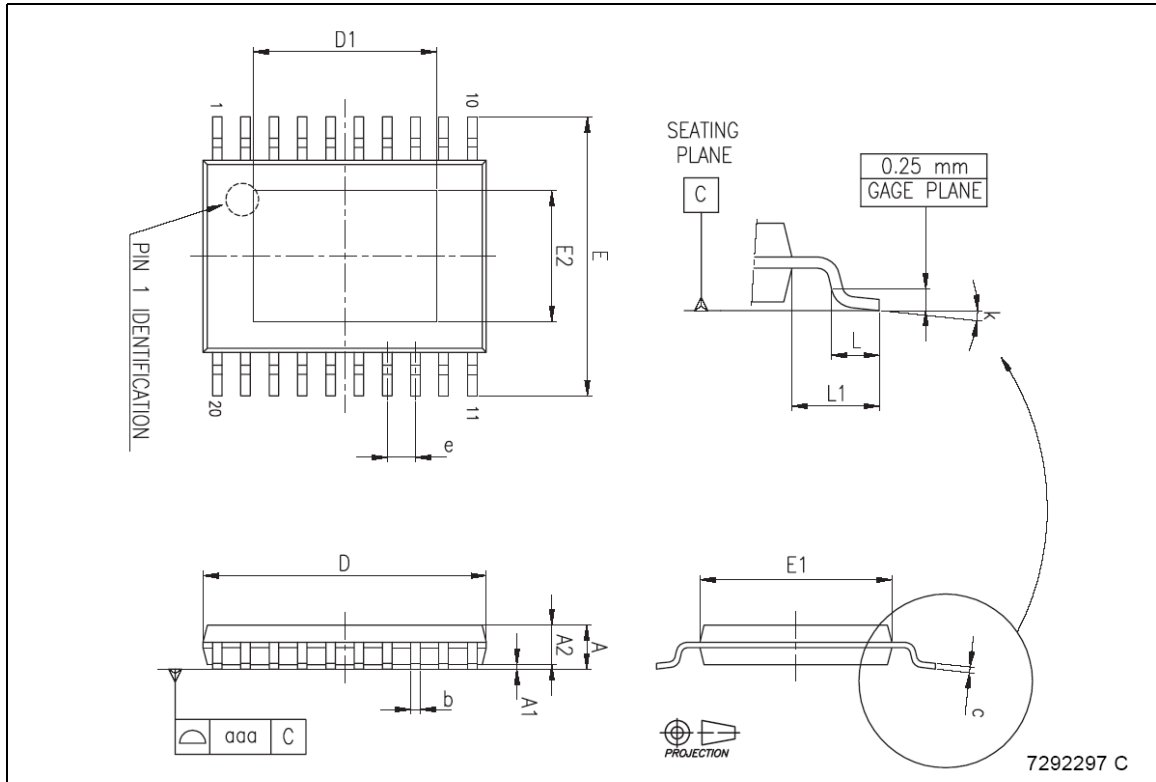

**Table 14. QFN 4mm x 4mm 24L mechanical data**

Dim	mm			inch		
	Min	Typ	Max	Min	Typ	Max
A			1.00			39.4
A1	0.00		0.05	0.0		2.0
b	0.18		0.30	7.1		11.8
D	3.9		4.1	153.5		161.4
D2	1.95		2.25	76.8		88.6
E	3.9		4.1	153.5		161.4
E2	1.95		2.25	76.8		88.6
e		0.50			19.7	
L	0.40		0.60	15.7		23.6

**Figure 43. Package dimensions**

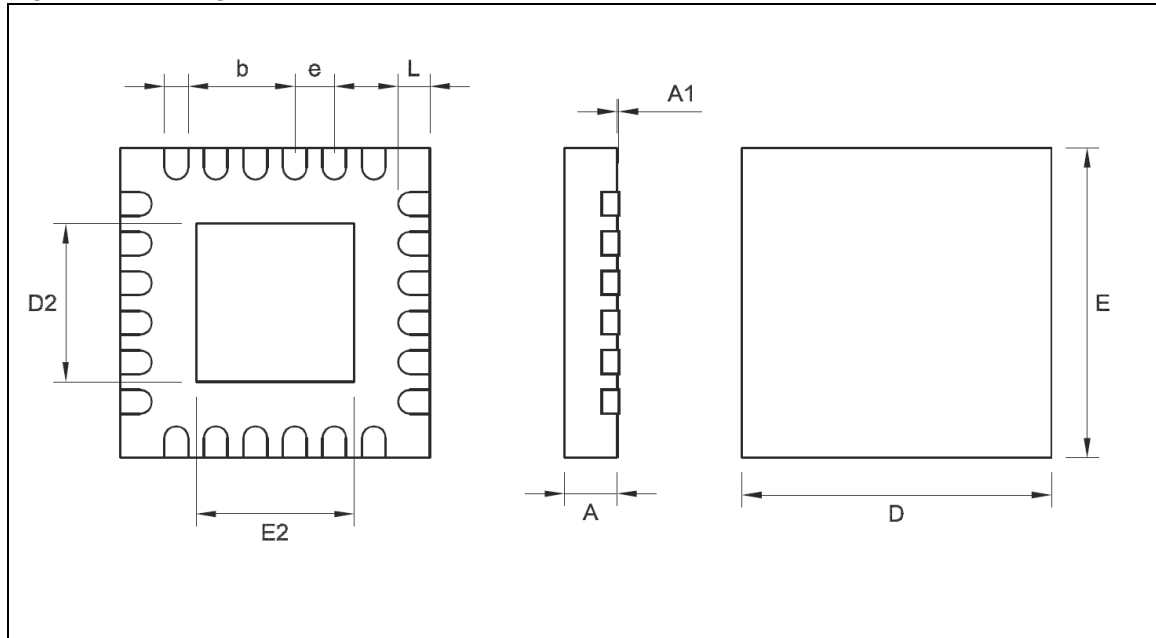



## 12 Revision history

**Table 15. Revision history**

<b>Date</b>	<b>Revision</b>	<b>Changes</b>
21-Dec-2005	1	Initial release.
07-Jun-2006	2	Added QFN package information, new template

**Please Read Carefully:**

Information in this document is provided solely in connection with ST products. STMicroelectronics NV and its subsidiaries ("ST") reserve the right to make changes, corrections, modifications or improvements, to this document, and the products and services described herein at any time, without notice.

All ST products are sold pursuant to ST's terms and conditions of sale.

Purchasers are solely responsible for the choice, selection and use of the ST products and services described herein, and ST assumes no liability whatsoever relating to the choice, selection or use of the ST products and services described herein.

No license, express or implied, by estoppel or otherwise, to any intellectual property rights is granted under this document. If any part of this document refers to any third party products or services it shall not be deemed a license grant by ST for the use of such third party products or services, or any intellectual property contained therein or considered as a warranty covering the use in any manner whatsoever of such third party products or services or any intellectual property contained therein.

**UNLESS OTHERWISE SET FORTH IN ST'S TERMS AND CONDITIONS OF SALE ST DISCLAIMS ANY EXPRESS OR IMPLIED WARRANTY WITH RESPECT TO THE USE AND/OR SALE OF ST PRODUCTS INCLUDING WITHOUT LIMITATION IMPLIED WARRANTIES OF MERCHANTABILITY, FITNESS FOR A PARTICULAR PURPOSE (AND THEIR EQUIVALENTS UNDER THE LAWS OF ANY JURISDICTION), OR INFRINGEMENT OF ANY PATENT, COPYRIGHT OR OTHER INTELLECTUAL PROPERTY RIGHT.**

**UNLESS EXPRESSLY APPROVED IN WRITING BY AN AUTHORIZED REPRESENTATIVE OF ST, ST PRODUCTS ARE NOT DESIGNED, AUTHORIZED OR WARRANTED FOR USE IN MILITARY, AIR CRAFT, SPACE, LIFE SAVING, OR LIFE SUSTAINING APPLICATIONS, NOR IN PRODUCTS OR SYSTEMS, WHERE FAILURE OR MALFUNCTION MAY RESULT IN PERSONAL INJURY, DEATH, OR SEVERE PROPERTY OR ENVIRONMENTAL DAMAGE.**

Resale of ST products with provisions different from the statements and/or technical features set forth in this document shall immediately void any warranty granted by ST for the ST product or service described herein and shall not create or extend in any manner whatsoever, any liability of ST.

ST and the ST logo are trademarks or registered trademarks of ST in various countries.

Information in this document supersedes and replaces all information previously supplied.

The ST logo is a registered trademark of STMicroelectronics. All other names are the property of their respective owners.

© 2006 STMicroelectronics - All rights reserved

STMicroelectronics group of companies

Australia - Belgium - Brazil - Canada - China - Czech Republic - Finland - France - Germany - Hong Kong - India - Israel - Italy - Japan - Malaysia - Malta - Morocco - Singapore - Spain - Sweden - Switzerland - United Kingdom - United States of America

[www.st.com](http://www.st.com)