

## Step-Down DC/DC Controller

**TLE 6389**

### Target Datasheet

#### Features

- Operation from 5V to 60V Input Voltage
- 100% Maximum Duty Cycle
- Efficiency >90%
- Output Current up to 3A
- Less than 100µA Quiescent Current
- 2µA Max Shutdown Current
- Up to 350kHz Switching Frequency
- Adjustable and Fixed 5V and 3.3V Output Voltage versions
- 3% output voltage accuracy (PWM Mode)
- Current-Mode Control Scheme
- On Chip Low Battery Detector
- Ambient operation range -40°C to 125°C

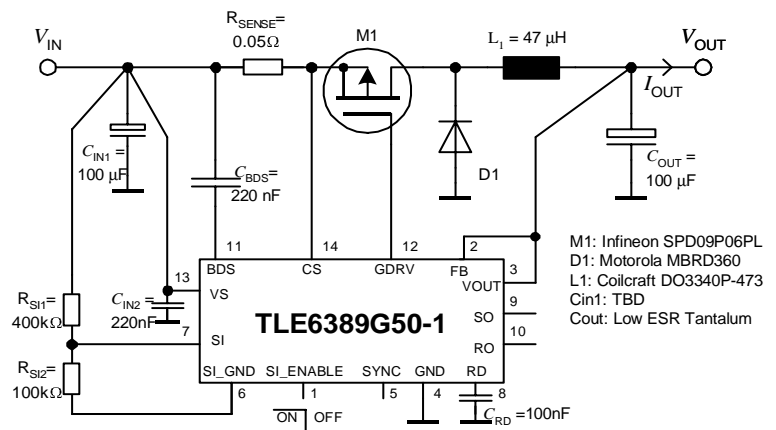
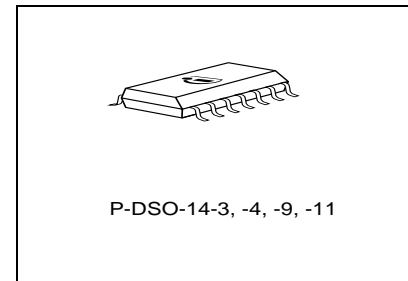

Type	Ordering Code	Package	Description
TLE 6389 GV	on request	P-DSO-14	adjustable
TLE 6389 G50	on request	P-DSO-14	5V, Device Enable
TLE 6389 G50-1	on request	P-DSO-14	5V, SI GND, SI Enable
TLE 6389 G33	on request	P-DSO-14	3.3V, Device Enable
TLE 6389 G33-1	on request	P-DSO-14	3.3V, SI GND, SI Enable

#### Functional description

The **TLE6389** step-down DC-DC switching controllers provide high efficiency over loads ranging from 1mA up to 3A. A unique PWM/PFM control scheme operates with up to a 100% duty cycle, resulting in very low dropout voltage. This control scheme eliminates minimum load requirements and reduces the supply current under light loads to 100µA. These step-down controllers drive an external P-channel MOSFET, allowing design flexibility for applications up to 3A. A high switching frequency (up to 350kHz) and

operation in continuous-conduction mode allow the use of tiny surface-mount inductors. Output capacitor requirements are also reduced, minimizing PC board area and system costs. The output voltage is preset at 5V (**TLE6389-50**) or 3.3V (**TLE6389-33**) and adjustable for the **TLE6389**. Input voltages can be up to 60V.

### Pin Configuration (top view)

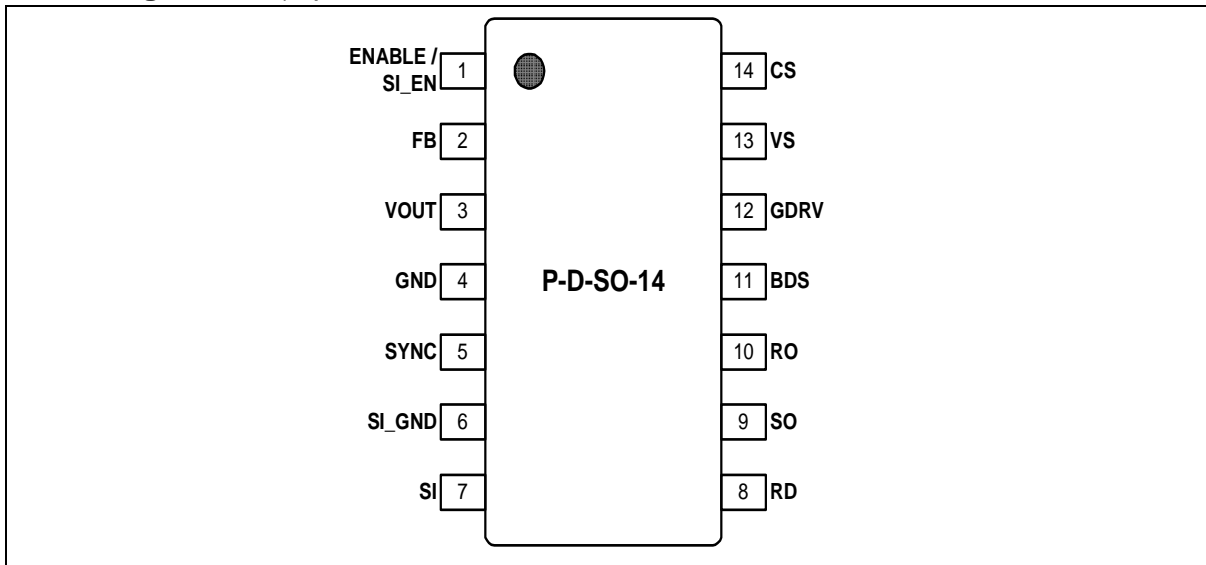

### Pin Definitions and Functions

Pin No SO-14	Symbol	Function
2	FB	<b>Feedback Input.</b> 1. For adjustable-output operation connect to an external voltage divider between the output and GND (see the Setting the Output Voltage section). 2. Sense input for fixed 5V or 3.3V output operation. FB is internally connected to an on-chip voltage divider.
3	VOUT	<b>VOUT Input.</b> Input for internal supply. Connect to output if variable version is used. For fixed voltage version connect FB and VOUT.
1	ENABLE	<b>Active-Low Enable Input.</b> Device is placed in shutdown when Enable is driven low. In shutdown mode, the reference, output, and external MOSFET are turned off. Connect to logic high for normal operation. (TLE6389G50, TLE6389G33, TLE6389GV only)

Pin No SO-14	Symbol	Function
1	SI_ENA BLE	<b>SI Enable Input.</b> SI_GND is switched to high impedance when SI_Enable is low. High level at SI_Enable connects SI_GND to GND via a low impedance path. SO is undefined when SI_Enable is low. (TLE6389G50-1, TLE6389G33-1 only)
13	VS	<b>Supply Input.</b> Bypass with 0.47µF.
4	GND	<b>Ground.</b> Analog signal ground.
6	SI_GND	<b>SI Ground.</b> Ground connection for SI comparator resistor divider.
11	BDS	<b>Buck Driver Supply Input.</b> Connect ceramic capacitor between BDS and VS to generate clamped gate-source voltage to drive the PMOS power stage.
14	CS	<b>Current-Sense Input.</b> Connect current-sense resistor between VS and CS. External MOSFET is turned off when the voltage across the resistor equals the current-limit trip level.
12	GDRV	<b>Gate Drive Output for External P-Channel MOSFET.</b> GDRV swings between VS and BDS.
10	RO	<b>Reset Output.</b> Open drain output from reset comparator with an internal pull up resistor.
8	RD	<b>Reset Delay.</b> Connect a capacitor to ground for delay time adjustment.
9	SO	<b>Sense Output Comparator.</b> Open drain output from SI comparator with an internal pull up resistor.
7	SI	<b>Sense Input Comparator.</b> Input to the Low-Battery Comparator. This input is compared to an internal 1.25V reference.
5	SYNC	<b>Input for external synchronization.</b> An external clock signal connected to this pin allows for GDRV switching synchronization.

**1 Absolute Maximum Ratings**

Item	Parameter	Symbol	Limit Values		Unit	Remarks
			min.	max.		
<b>Supply Input</b>						
1.0.1	Voltage	$V_S$	-0.3	60	V	–
1.0.2	Current	$I_S$	–	–	–	
<b>Current Sense Input</b>						
1.0.3	Voltage	$V_{CS}$	-0.3	60	V	–
1.0.4	Current	$I_{CS}$	–	–	–	
<b>Gate Drive Output</b>						
1.0.5	Voltage	$V_{GDRV}$	– 0.3	6.8	V	$ V_S - V_{GDRV}  < 6.8V$
1.0.6	Current	$I_{GDRV}$	–	–	–	Internally limited
<b>Buck Drive Supply Input</b>						
1.0.7	Voltage	$V_{BDS}$	– 0.3	55	V	$ V_S - V_{BDS}  < 6.8V$
1.0.8	Current	$I_{BDS}$	–	–	–	
<b>Feedback Input</b>						
1.0.9	Voltage	$V_{FB}$	– 0.3	6.8	V	
1.0.10	Current	$I_{FB}$	–	–	–	
<b>SI_Enable Input</b>						
1.0.11	Voltage	$V_{SI\_ENAB}$ <i>LE</i>	– 0.3	6.8	V	(TLE6389G50-1, TLE6389G33-1 only)
1.0.12	Current	$I_{SI\_ENABL}$ <i>E</i>	–	–	–	
<b>SI_GND Input</b>						
1.0.13	Voltage	$V_{SI\_GND}$	– 0.3	60	V	(TLE6389G50-1, TLE6389G33-1 only)
1.0.14	Current	$I_{SI\_GND}$	–	–	–	
<b>Enable Input</b>						

**1 Absolute Maximum Ratings (cont'd)**

Item	Parameter	Symbol	Limit Values		Unit	Remarks
			min.	max.		
1.0.15	Voltage	$V_{ENABLE}$	- 0.3	60	V	(TLE6389G50, TLE6389G33, TLE6389GV only)
1.0.16	Current	$I_{ENABLE}$	-	-	-	
<b>Sense Input</b>						
1.0.17	Voltage	$V_{SI}$	- 0.3	60	V	
1.0.18	Current	$I_{SI}$	-	-	-	
<b>Sense Output</b>						
1.0.19	Voltage	$V_{SO}$	- 0.3	6.8	V	
1.0.20	Current	$I_{SO}$	-	-	-	
<b>VOUT Input</b>						
1.0.21	Voltage	$V_{OUT}$	- 0.3	15	V	
1.0.22	Current	$I_{OUT}$	-	-	-	
<b>Reset Delay Adjust Input</b>						
1.0.23	Voltage	$V_{RD}$	- 0.3	6.8	V	
1.0.24	Current	$I_{RD}$	TBD	TBD	mA	
<b>Reset Output</b>						
1.0.25	Voltage	$V_{RO}$	- 0.3	6.8	V	
1.0.26	Current	$I_{RO}$	-2	2	mA	
<b>Synchronization Input</b>						
1.0.27	Voltage	$V_{SYNC}$	- 0.3	6.8	V	
1.0.28	Current	$I_{SYNC}$	TBD	TBD	mA	
<b>ESD-Protection (Human Body Model; R=1,5kΩ; C=100pF)</b>						
1.0.29	all pins to GND	$V_{HBM}$	-2	2	kV	

**1 Absolute Maximum Ratings (cont'd)**

Item	Parameter	Symbol	Limit Values		Unit	Remarks
			min.	max.		
<b>Temperatures</b>						
1.0.30	Junction temperature	$T_j$	- 40	150	°C	-
1.0.31	Storage temperature	$T_{stg}$	- 50	150	°C	-

*Note: Maximum ratings are absolute ratings; exceeding any one of these values may cause irreversible damage to the integrated circuit.*

## 2 Operating Range

Item	Parameter	Symbol	Limit Values		Unit	Remarks
			min.	max.		
2.0.1	Supply voltage range	$V_S$	5	48	V	
2.0.2	Junction temperature	$T_j$	- 40	150	°C	
<b>Thermal Resistance</b>						
2.0.3	Junction ambient	$R_{thj-a}$		180	K/W	-
2.0.4	Junction pin	$R_{thj-p}$		TBD	K/W	-

## 3 Electrical Characteristics

$5V < V_S < 48V$ ;  $-40^{\circ}C < T_j < 150^{\circ}C$ ;

all voltages with respect to ground; positive current defined flowing into the pin; unless otherwise specified

Item	Parameter	Symbol	Limit Values			Unit	Test Condition
			min.	typ.	max.		
<b>Current Consumption<sup>1)</sup> TLE6389 (variable)</b>							
3.0.1	Supply current into VS	$I_S$			80	$\mu A$	$V_S = 13.5 V$ ; $V_{ENABLE} = 5 V$ ; $I_{OUT} = 0 mA$ ; $T_J = 25^{\circ}C$ ;
3.0.2					110	$\mu A$	$V_S = 42 V$ ; $V_{ENABLE} = 5 V$ ; $I_{OUT} = 0 mA$ ; $T_J = 25^{\circ}C$ ;
3.0.3						2	$\mu A$
3.0.4	FB current	$I_{FB}$			4	$\mu A$	$V_{ENABLE} = 5 V$ ; $T_J = 25^{\circ}C$ ;

**3 Electrical Characteristics (cont'd)**
 $5V < V_S < 48V$ ;  $-40^{\circ}C < T_j < 150^{\circ}C$ ;

all voltages with respect to ground; positive current defined flowing into the pin; unless otherwise specified

Item	Parameter	Symbol	Limit Values			Unit	Test Condition
			min.	typ.	max.		
<b>Current Consumption TLE6389-50</b>							
3.0.5	Supply current into VS	$I_S$			50	$\mu A$	$V_S = 13.5 V$ ; $V_{ENABLE} = 5 V$ ; $I_{OUT} = 0 mA$ ; $T_J = 25^{\circ}C$ ;
3.0.6					80	$\mu A$	$V_S = 42 V$ ; $V_{ENABLE} = 5 V$ ; $I_{OUT} = 0 mA$ ; $T_J = 25^{\circ}C$ ;
3.0.7					2	$\mu A$	$V_{ENABLE} = 0V$
3.0.8	FB current	$I_{FB}$			50	$\mu A$	$V_{ENABLE} = 5 V$ ; $V_{OUT} = 5 V$ ; $T_J = 25^{\circ}C$ ;
<b>Current Consumption TLE6389-33</b>							
3.0.9	Supply current into VS	$I_S$			80	$\mu A$	$V_S = 13.5 V$ ; $V_{ENABLE} = 5 V$ ; $I_{OUT} = 0 mA$ ; $T_J = 25^{\circ}C$ ;
3.0.10					110	$\mu A$	$V_S = 42 V$ ; $V_{ENABLE} = 5 V$ ; $I_{OUT} = 0 mA$ ; $T_J = 25^{\circ}C$ ;
3.0.11					2	$\mu A$	$V_{ENABLE} = 0V$
<b>Current Consumption TLE6389-50-1</b>							



### 3 Electrical Characteristics (cont'd)

 $5V < V_S < 48V; -40^{\circ}C < T_J < 150^{\circ}C;$ 

all voltages with respect to ground; positive current defined flowing into the pin; unless otherwise specified

Item	Parameter	Symbol	Limit Values			Unit	Test Condition
			min.	typ.	max.		
3.0.12	Supply current into VS	$I_S$			50	$\mu A$	$V_S = 13.5 V;$ $I_{OUT} = 0 mA;$ $T_J = 25^{\circ}C;$
3.0.13					80	$\mu A$	$V_S = 42 V;$ $I_{OUT} = 0 mA;$ $T_J = 25^{\circ}C;$
3.0.14	FB current	$I_{FB}$			50	$\mu A$	$V_{OUT} = 5 V;$ $T_J = 25^{\circ}C;$
<b>Current Consumption TLE6389-33-1</b>							
3.0.15	Supply current into VS	$I_S$			80	$\mu A$	$V_S = 13.5 V;$ $I_{OUT} = 0 mA;$ $T_J = 25^{\circ}C;$
3.0.16					110	$\mu A$	$V_S = 42 V;$ $I_{OUT} = 0 mA;$ $T_J = 25^{\circ}C;$
3.0.17	FB current	$I_{FB}$			15	$\mu A$	$V_{OUT} = 3.3 V;$ $T_J = 25^{\circ}C;$
<b>Buck-Controller</b>							
3.0.18	Output voltage	$V_{OUT}$	4.85	5	5.15	V	5V Versions; $V_S = 5.8 V$ to 48V; $I_{OUT} =$ TBDmA to 2A (PWM Mode); $R_{SENSE} = 0.05\Omega;$ $R_{M1} = 0.25\Omega; R_{L1}$ $= 0.1\Omega;$

### 3 Electrical Characteristics (cont'd)

 $5V < V_S < 48V; -40^{\circ}C < T_j < 150^{\circ}C;$ 

all voltages with respect to ground; positive current defined flowing into the pin; unless otherwise specified

Item	Parameter	Symbol	Limit Values			Unit	Test Condition
			min.	typ.	max.		
3.0.19	Output voltage	$V_{OUT}$	4.75	5	5.25	V	5V Versions; $V_S = 5.8V$ to 48V; $I_{OUT} = 0mA$ to TBDA (PFM Mode); $R_{SENSE} =$ $0.05\Omega$ ; $R_{M1} =$ $0.25\Omega$ ; $R_{L1} =$ $0.1\Omega$ ;
3.0.20			3.8			V	5V Versions; $V_S = 4.2V$ to 5.8V; $I_{OUT} =$ 0mA to 500mA; $R_{SENSE} = 0.1\Omega$ ; $R_{M1} = 0.4\Omega$ ; $R_{L1}$ $= 0.1\Omega$ ;
3.0.21	Output voltage	$V_{OUT}$	-3%	3.3	+3%	V	3.3V Versions; $V_S = 5V$ to 48V; $I_{OUT} = TBD$ to 2A (PWM Mode);
3.0.22			-5%	3.3	+5%	V	3.3V Versions; $V_S = 5V$ to 48V; $I_{OUT} = 0mA$ to TBD (PFM Mode);
3.0.23	FB threshold voltage	$V_{FB,th}$	1.22 5	1.25	1.27 5	V	TLE6389GV
3.0.24	Output adjust range		5		15	V	TLE6389GV
3.0.25	Line regulation			0.7	1	mV/ V	TBD
3.0.26	Load regulation			20	30	mV/ A	$I_{OUT} = 5mA$ to 2A;
3.0.27	Gate driver, P-gate to source voltage (off)	$V_{GDRV} -$ $V_S$	0		0.2	V	$V_{ENABLE} = 5V$ $C_{BDS} = 220nF$ $C_{GDRV} = 5nF$

### 3 Electrical Characteristics (cont'd)

 $5V < V_S < 48V; -40^{\circ}C < T_j < 150^{\circ}C;$ 

all voltages with respect to ground; positive current defined flowing into the pin; unless otherwise specified

Item	Parameter	Symbol	Limit Values			Unit	Test Condition
			min.	typ.	max.		
3.0.28	Gate driver, P-gate to source voltage (on)	$V_{GDRV} - V_S$	TBD		6.5	V	$V_{ENABLE} = 5V$ $C_{BDS} = 220nF$ $C_{GDRV} = 5nF$
3.0.29	Gate driver, peak charging current	$I_{GDRV}$		TBD		A	
3.0.30	Gate driver, peak discharging current	$I_{GDRV}$		TBD		A	
3.0.31	Gate driver, rise time	$t_r$		70		ns	$V_{ENABLE} = 5V$ $C_{BDS} = 220nF$ $C_{GDRV} = 5nF$
3.0.32	Gate driver, fall time	$t_f$		100		ns	$V_{ENABLE} = 5V$ $C_{BDS} = 220nF$ $C_{GDRV} = 5nF$
3.0.33	Gate driver, gate charge	$Q_{GDRV}$	50			nC	
3.0.34	Current Limit Threshold Voltage	$V_{LIM} = V_{VS} - V_{CS}$	70	100	130	mV	
3.0.35	PWM to PFM Threshold Current			0.1* $I_{LIM}$		mA	$I_{LIM} = V_{LIM} / R_{SENSE}$
3.0.36	PFM to PWM Threshold Timing	$t_{off\_PFM}$		TBD		$\mu s$	
3.0.37	Oscillator frequency	$f_{OSC}$	270	360	450	kHz	PWM mode only
3.0.38	Maximum duty cycle	$d_{MAX}$	100			%	PWM mode only
3.0.39	Minimum duty cycle	$d_{MIN}$			TBD	%	PWM mode only
3.0.40	SYNC capture range		270	360	450	kHz	PWM mode only

### 3 Electrical Characteristics (cont'd)

 $5V < V_S < 48V$ ;  $-40^{\circ}C < T_j < 150^{\circ}C$ ;

all voltages with respect to ground; positive current defined flowing into the pin; unless otherwise specified

Item	Parameter	Symbol	Limit Values			Unit	Test Condition
			min.	typ.	max.		
<b>Reset Generator</b>							
3.0.41	Reset threshold	$V_{RT}$		0.9* 1.25		V	TLE6389GV only; $V_{OUT}$ decreasing
3.0.42	Reset threshold hysteresis	$V_{RT,hys}$		100		mV	TLE6389GV only
3.0.43	Reset threshold	$V_{RT}$	3.5	3.65	3.8	V	5V Versions; $V_{OUT}$ decreasing
3.0.44			4.5	4.65	4.8	V	5V Versions; $V_{OUT}$ increasing
3.0.45	Reset threshold	$V_{RT}$	2.8	2.95	3.1	V	3.3V Versions; $V_{OUT}$ decreasing
3.0.46			2.9	3.05	3.2	V	3.3V Versions; $V_{OUT}$ increasing
3.0.47	Reset pull up	$R_{RO}$	10	20	40	k $\Omega$	3.3V and 5V Versions; Internally connected to $V_{OUT}$
3.0.48	Reset output High voltage	$V_{ROH}$	0.8* $V_{OUT}$			V	3.3V and 5V Versions; $I_{ROH}=0$ mA
3.0.49	Reset output Low voltage	$V_{ROL}$		0.2	0.4	V	$I_{ROL}=1$ mA; $2.5V < V_{OUT} < V_{RT}$
3.0.50					0.2	0.4	V
3.0.51	Reset delay charging current	$I_d$		4		$\mu$ A	$V_D = 1V$

### 3 Electrical Characteristics (cont'd)

$5V < V_S < 48V$ ;  $-40^{\circ}C < T_j < 150^{\circ}C$ ;

all voltages with respect to ground; positive current defined flowing into the pin; unless otherwise specified

Item	Parameter	Symbol	Limit Values			Unit	Test Condition
			min.	typ.	max.		
3.0.52	Upper reset timing threshold	$V_{RDO}$		tbd		V	--
3.0.53	Lower timing threshold	$V_{RDL}$		tbd		V	--
3.0.54	Reset delay time	$t_d$	35	50	70	ms	$C_{RD} = 100nF$
3.0.55	Reset reaction time	$t_{rr}$			10	$\mu s$	$C_{RD} = 100nF$
3.0.56	Reset Output delay	$t_{ROd}$			1	$\mu s$	$C_{RD} = 100nF$
<b>ENABLE Input</b>							
3.0.57	Enable ON-threshold	$V_{ENABLE, ON}$	2			V	
3.0.58	Enable OFF-threshold	$V_{ENABLE, OFF}$			0.8	V	
3.0.59	H-level input current	$I_{ENABLE, ON}$			5	$\mu A$	
3.0.60	L-level input current	$I_{ENABLE, OFF}$			2	$\mu A$	
<b>SI_ENABLE Input</b>							
3.0.61	Enable ON-threshold	$V_{ENABLE, ON}$	2			V	
3.0.62	Enable OFF-threshold	$V_{ENABLE, OFF}$			0.8	V	
3.0.63	H-level input current	$I_{ENABLE, ON}$			5	$\mu A$	

### 3 Electrical Characteristics (cont'd)

 $5V < V_S < 48V$ ;  $-40^{\circ}C < T_j < 150^{\circ}C$ ;

all voltages with respect to ground; positive current defined flowing into the pin; unless otherwise specified

Item	Parameter	Symbol	Limit Values			Unit	Test Condition
			min.	typ.	max.		
3.0.64	L-level input current	$I_{ENABLE,O}$ FF			2	$\mu A$	
<b>SI_GND Input</b>							
3.0.65	Switch ON resistance	$R_{SW}$		100		$\Omega$	$T_j=25^{\circ}C$ ; $I_{SI\_GND} = TB\mu A$
<b>Battery Voltage Sense</b>							
3.0.66	Sense threshold high to low	$V_{si, high}$	1.13	1.25	1.37	V	
3.0.67	Sense threshold hysteresis	$V_{si, hys}$	–	100	–	mV	–
3.0.68	Sense out pull up	$R_{SO}$	10	20	40	k $\Omega$	3.3V and 5V Versions; Internally connected to $V_{OUT}$
3.0.69	Sense out output High voltage	$V_{SOH}$	0.8* $V_{OUT}$			V	$I_{SOH}=0mA$
3.0.70	Sense out output Low voltage	$V_{SOL}$		0.2	0.4	V	$I_{SOL}=1mA$ ; $2.5V < V_{OUT}$ ; $V_{SI} < 1.13 V$
3.0.71				0.2	0.4	V	$I_{SOL}=0.2mA$ ; $1V < V_{OUT} < 2.5V$ ; $V_{SI} < 1.13 V$
3.0.72	Sense input current	$I_{SI}$	– 1	0.1	1	$\mu A$	–
<b>Thermal Shutdown</b>							

### 3 Electrical Characteristics (cont'd)

$5V < V_S < 48V$ ;  $-40^{\circ}\text{C} < T_j < 150^{\circ}\text{C}$ ;

all voltages with respect to ground; positive current defined flowing into the pin; unless otherwise specified

Item	Parameter	Symbol	Limit Values			Unit	Test Condition
			min.	typ.	max.		
3.0.73	Thermal shutdown junction temperature	$T_{jSD}$	150	175	200	$^{\circ}\text{C}$	
3.0.74	Temperature hysteresis	DT		30		K	

- <sup>1)</sup> The device  $I_S$  and  $I_{FB}$  current measurements exclude MOSFET driver currents. Contribution of MOSFET driver currents are discussed in application section.

#### 4 Detailed Description

The **TLE6389** family is a family of step-down DC-DC controllers designed primarily for use in high voltage applications such as automotive. Using an external MOSFET and current-sense resistor allows design flexibility and the improved efficiencies associated with high-performance P-channel MOSFETs. A unique, current-limited, pulse-width (PWM)/pulse-frequency-modulated (PFM) control scheme gives these devices excellent efficiency over load ranges up to three decades, while drawing less than 100µA under no load. This wide dynamic range optimizes the **TLE6389** for automotive applications, where load currents can vary considerably as individual circuit blocks are turned on and off to conserve energy. Operation to a 100% duty cycle allows the lowest possible dropout voltage, allowing operation during cold cranking. High switching frequencies and a simple circuit topology minimize PC board area and component costs.

The output voltage is sensed either by an internal voltage divider connected to the FB pin (**TLE6389-50** and **TLE6389-33**) or an external divider returned to the FB pin (**TLE6389**).

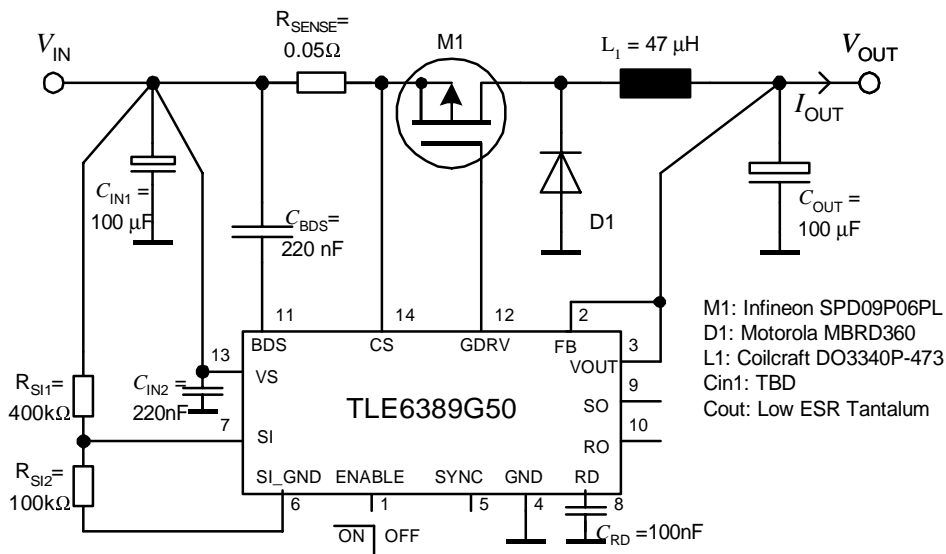

**TLE6389G50 Application Circuit**



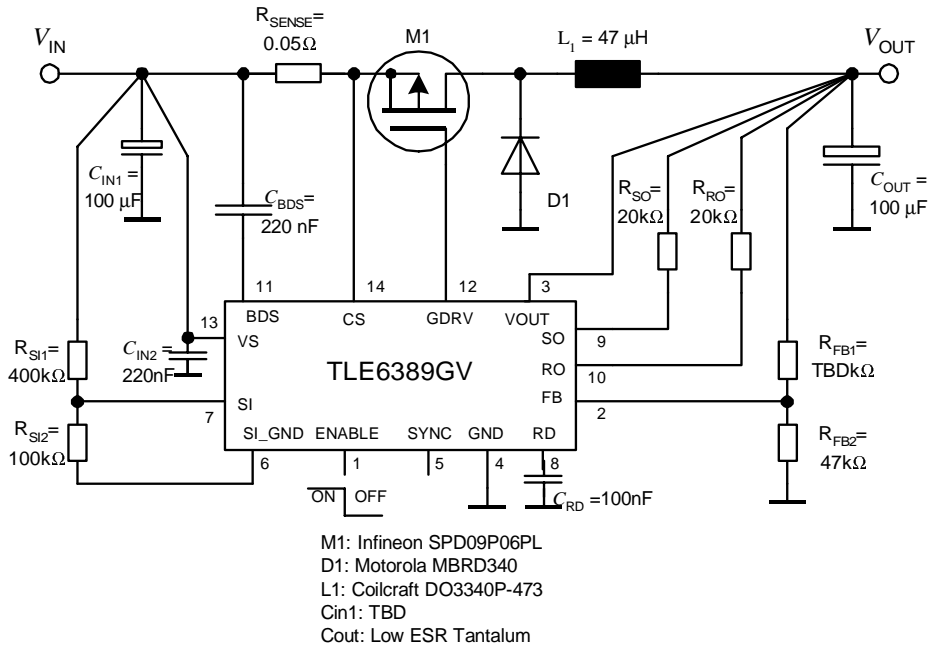

**TLE6389GV Application Circuit**

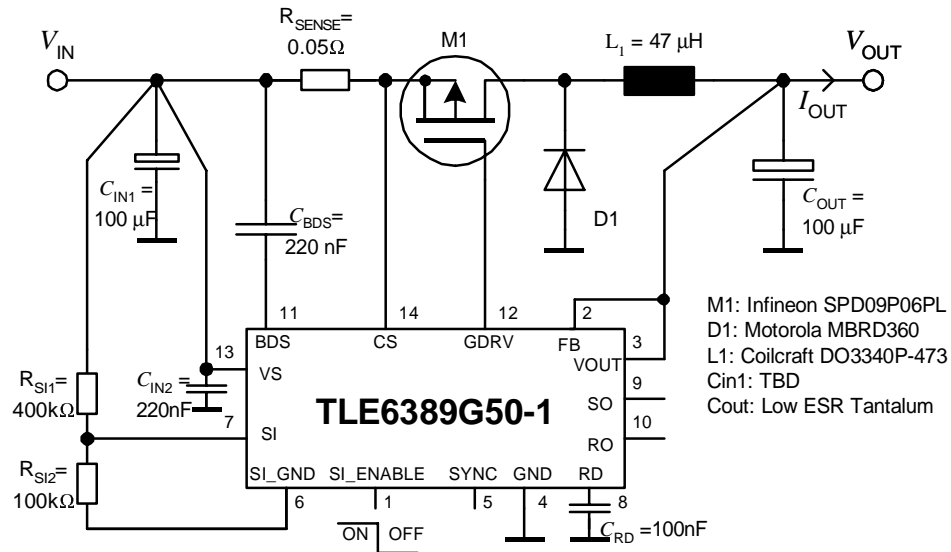

**TLE6389G50-1 Application Circuit**

## 4.1 Operating Modes

### 4.1.1 PWM Control Scheme

The **TLE6389** uses a slope-compensated, current-mode PWM controller capable of achieving 100% duty cycle. The device uses an oscillator-triggered, minimum on-time, current-mode control scheme. The minimum on-time is approximately 200ns unless in dropout. The maximum on-time is greater than  $1/f_{OSC}$ , allowing operation to 100% duty cycle. Current-mode feedback provides cycle-by-cycle current limiting for superior load- and line-response and protection of the external MOSFET and rectifier diode. At each falling edge of the internal oscillator, the oscillator cell sends a PWM ON signal to the control and drive logic, turning on the external P-channel MOSFET. This allows current to ramp up through the inductor to the load, and stores energy in a magnetic field. The switch remains on until either the current-limit comparator is tripped or the PWM comparator signals that the output is in regulation. When the switch turns off during the second half of each cycle, the inductor's magnetic field collapses, releasing the stored energy and forcing current through the rectifier diode to the output-filter capacitor and load. The output-filter capacitor stores charge when the inductor current is high and releases it when the inductor current is low, thus smoothing the voltage across the load. During normal operation, the **TLE6389** regulates output voltage by switching at a constant frequency and then modulating the power transferred to the load each cycle using the PWM comparator. A multi-input comparator sums three weighted differential signals: the output voltage with respect to the reference, the main switch current sense, and the slope-compensation ramp. It modulates output power by adjusting the inductor-peak current during the first half of each cycle, based on the output-error voltage.

### 4.1.2 100% Duty-Cycle Operation and Dropout

The **TLE6389** operates with a duty cycle up to 100%. This feature extends allows to operate with the lowest possible drop at low battery voltage as it occurs at cold ambient temperatures. The MOSFET is turned on continuously when the supply voltage approaches the output voltage. This services the load when conventional switching regulators with less than 100% duty cycle would fail. Dropout voltage is defined as the difference between the input and output voltages when the input is low enough for the output to drop out of regulation. Dropout depends on the MOSFET drain-to-source on-resistance, current-sense resistor, and inductor series resistance, and is proportional to the load current:

$$\text{Dropout Voltage} = I_{OUT} \times (R_{DS(ON)} + R_{SENSE} + R_{INDUCTOR})$$

### 4.1.3 PWM/PFM Operation

This control scheme overrides PWM mode and places the **TLE6389** in PFM mode at light loads to improve efficiency and reduce quiescent current to less than 100µA. The pulse-skipping PFM operation is initiated when the peak inductor current drops below  $0.1 \times I_{\text{limit}}$ . During PFM operation, the **TLE6389** switches only as needed to service the load, reducing the switching frequency and associated losses in the external switch, the rectifier diode, and the external inductor. During PFM mode, a switching cycle initiates when the PFM comparator senses that the output voltage has dropped too low. The P-channel MOSFET switch turns on and conducts current to the output-filter capacitor and load until the inductor current reaches the PFM peak voltage limit. Then the switch turns off and the magnetic field in the inductor collapses, forcing current through the synchronous rectifier to the output filter capacitor and load. Then the **TLE6389** waits until the PFM comparator senses a low output voltage again.

Output ripple is higher during PFM operation. A larger output-filter capacitor can be used to minimize ripple.

### 4.2 SYNC Input and Frequency Control

The **TLE6389**'s internal oscillator is set for a fixed-switching frequency of 360kHz or can be synchronized to an external clock. Do not leave SYNC unconnected. Connecting SYNC to GND enables PWM/PFM operation to reduce supply current at light loads. SYNC is a negative-edge triggered input that allows synchronization to an external frequency ranging between 270kHz and 450kHz. When SYNC is clocked by an external signal, the converter operates in PWM mode until the load current drops below the PWM to PFM threshold. Thereafter the converter continues operation in PFM mode.

### 4.3 Shutdown Mode

Connecting ENABLE to GND places the **TLE6389GV**, **TLE6389G33** and **TLE6389G50** in shutdown mode. In shutdown, the reference, control circuitry, external switching MOSFET, and the oscillator are turn off and the output falls to 0V. Connect ENABLE to IN for normal operation.

### 4.4 SI\_Enable

Connecting SI\_ENABLE to 5V causes SI\_GND to have low impedance. Thus the SI comparator is operational and can be used to monitor the battery voltage. SO output signal is valid. Connecting SI\_ENABLE to GND causes SI\_GND to have high impedance. Thus the SI comparator is not able to monitor the battery voltage. SO output signal is invalid.

## 4.5 Quiescent Current

The device's typical quiescent current is 50µA. However, actual applications draw additional current to supply MOSFET switching currents, FB pin current, or external feedback resistors (if used), and both the diode and capacitor leakage currents. For example, with VS at 13.5V and VOUT at 5V, typical no-load supply current for the entire circuit is TBDµA. When designing a circuit for high-temperature operation, select a Schottky diode with low reverse leakage.

## 5 Application Information

### 5.1 Output Voltage Selection (TLE6389GV only)

Select an output voltage between 5V and 15V by connecting FB to a resistor-divider between the output and GND. Select feedback resistor R2 in the 5kΩ to 500kΩ range. R1 is then given by:

$$R1 = R2 [(VOUT / VFB) - 1]$$

where VFB = 1.25V. Add a small ceramic capacitor around 47pF to 100pF in parallel with R1 to compensate for stray capacitance at the FB pin and output capacitor equivalent series resistance (ESR).

### 5.2 Output Capacitor Selection

Choose input- and output-filter capacitors to service inductor currents with acceptable voltage ripple. The input-filter capacitor also reduces peak currents and noise at the voltage source. In addition, connect a low-ESR bulk capacitor (>10µF suggested) to the input. Select this bulk capacitor to meet the input ripple requirements and voltage rating, rather than capacitor size. Use the following equation to calculate the maximum RMS input current:

$$I_{RMS} = I_{OUT} [V_{OUT} (V_{IN} - V_{OUT})]^{1/2} \cdot V_{IN}$$

When selecting an output capacitor, consider the output-ripple voltage and approximate it as the product of the ripple current and the ESR of the output capacitor.

$$V_{RIPPLE} = [V_{OUT} (V_{IN} - V_{OUT})] / [2 \cdot f_{OSC}(L) (V_{IN})] \cdot ESR_{COUT}$$

where ESR<sub>COUT</sub> is the equivalent-series resistance of the output capacitor. Higher values of C<sub>OUT</sub> provide improved output ripple and transient response. Lower oscillator frequencies require a larger-value output capacitor. Verify capacitor selection with light loads during PFM operation, since output ripple is higher under these conditions. Low-ESR capacitors are recommended. Capacitor ESR is a major contributor to output ripple (usually more than 60%). Ordinary aluminum-electrolytic capacitors have high ESR and should be avoided. Low-ESR aluminum-electrolytic capacitors are acceptable and relatively inexpensive. Low-ESR tantalum capacitors are better and provide a compact

---

solution for space-constrained surface-mount designs. Do not exceed the ripple-current ratings of tantalum capacitors. Ceramic capacitors have the lowest ESR overall.

## 6 Package Outlines

Dimensions in mm

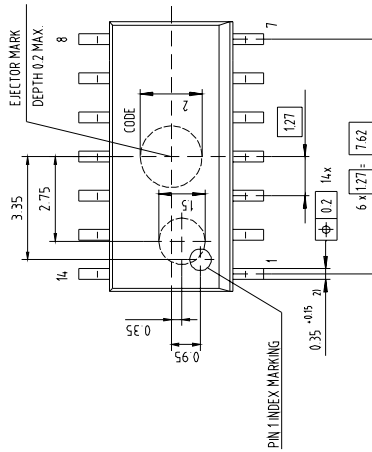
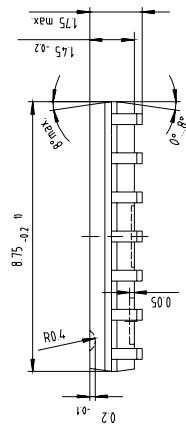
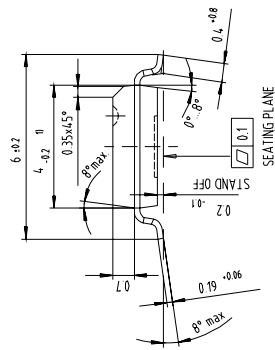

**Published by Infineon Technologies AG,  
St.-Martin-Strasse 53  
D-81541 München  
© Infineon Technologies AG2000  
All Rights Reserved.**

**Attention please!**

The information herein is given to describe certain components and shall not be considered as warranted characteristics.

Terms of delivery and rights to technical change reserved.

We hereby disclaim any and all warranties, including but not limited to warranties of non-infringement, regarding circuits, descriptions and charts stated herein.

Infineon Technologies is an approved CECC manufacturer.

**Information**

For further information on technology, delivery terms and conditions and prices please contact your nearest Infineon Technologies Office in Germany or our Infineon Technologies Representatives worldwide (see address list).

**Warnings**

Due to technical requirements components may contain dangerous substances. For information on the types in question please contact your nearest Infineon Technologies Office.

Infineon Technologies Components may only be used in life-support devices or systems with the express written approval of Infineon Technologies, if a failure of such components can reasonably be expected to cause the failure of that life-support device or system, or to affect the safety or effectiveness of that device or system. Life support devices or systems are intended to be implanted in the human body, or to support and/or maintain and sustain and/or protect human life. If they fail, it is reasonable to assume that the health of the user or other persons may be endangered.