

NCP3064, NCP3064B, NCV3064



ON Semiconductor®

<http://onsemi.com>

1.5 A, Step-Up/Down/Inverting Switching Regulator with ON/OFF Function

The NCP3064 Series is a higher frequency upgrade to the popular MC33063A and MC34063A monolithic DC-DC converters. These devices consist of an internal temperature compensated reference, comparator, controlled duty cycle oscillator with an active current limit circuit, driver and high current output switch. This series was specifically designed to be incorporated in Step-Down and Step-Up and Voltage-Inverting applications with a minimum number of external components. The ON/OFF pin provides a low power shutdown mode.

Features

- Input Voltage Range from 3.0 V to 40 V
- Logic Level Shutdown Capability
- Low Power Standby Mode, Typical 100 μ A
- Output Switch Current to 1.5 A
- Adjustable Output Voltage Range
- 150 kHz Frequency Operation
- Precision 1.5% Reference
- Internal Thermal Shutdown Protection
- Cycle-by-Cycle Current Limiting
- NCV Prefix for Automotive and Other Applications Requiring Site and Control Changes
- These are Pb-Free Devices

Applications

- Step-Down, Step-Up and Inverting supply applications
- High Power LED Lighting
- Battery Chargers

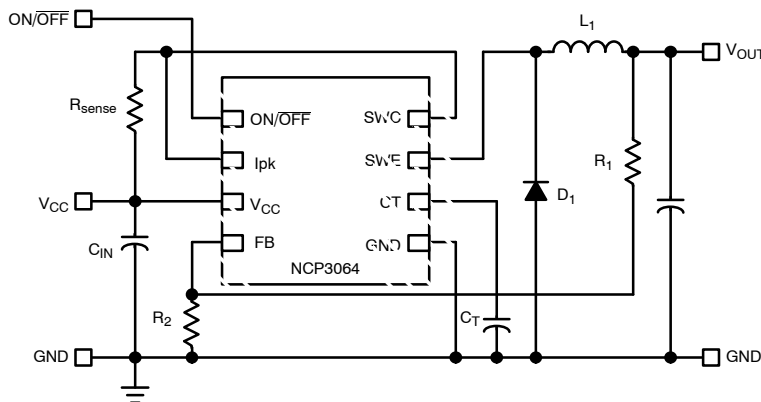
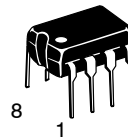
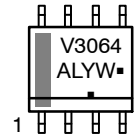
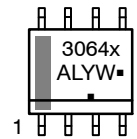

Figure 1. Typical Buck Application Circuit

MARKING DIAGRAMS



SOIC-8
D SUFFIX
CASE 751



PDIP-8
P, P1 SUFFIX
CASE 626

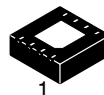
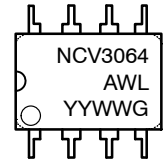
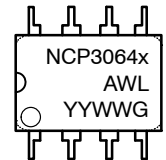

DFN8
MN SUFFIX
CASE 488AF

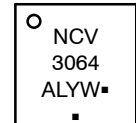
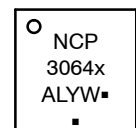

NCP3064 = Specific Device Code
 x = B
 A = Assembly Location
 L, WL = Wafer Lot
 Y, YY = Year
 W, WW = Work Week
 G or ■ = Pb-Free Package

(Note: Microdot may be in either location)

ORDERING INFORMATION

See detailed ordering and shipping information in the package dimensions section on page 17 of this data sheet.

NCP3064, NCP3064B, NCV3064

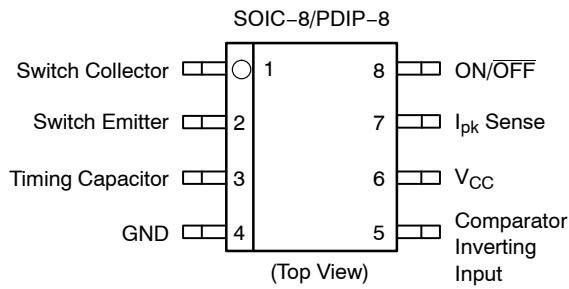
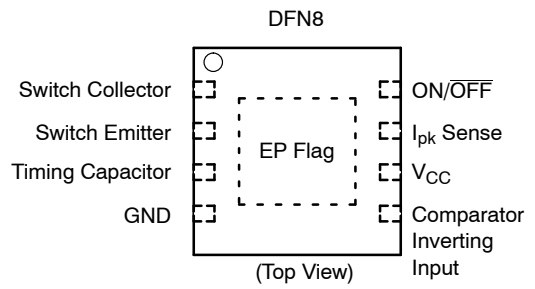

Figure 2. Pin Connections



NOTE: EP Flag must be tied to GND Pin 4 on PCB

Figure 3. Pin Connections

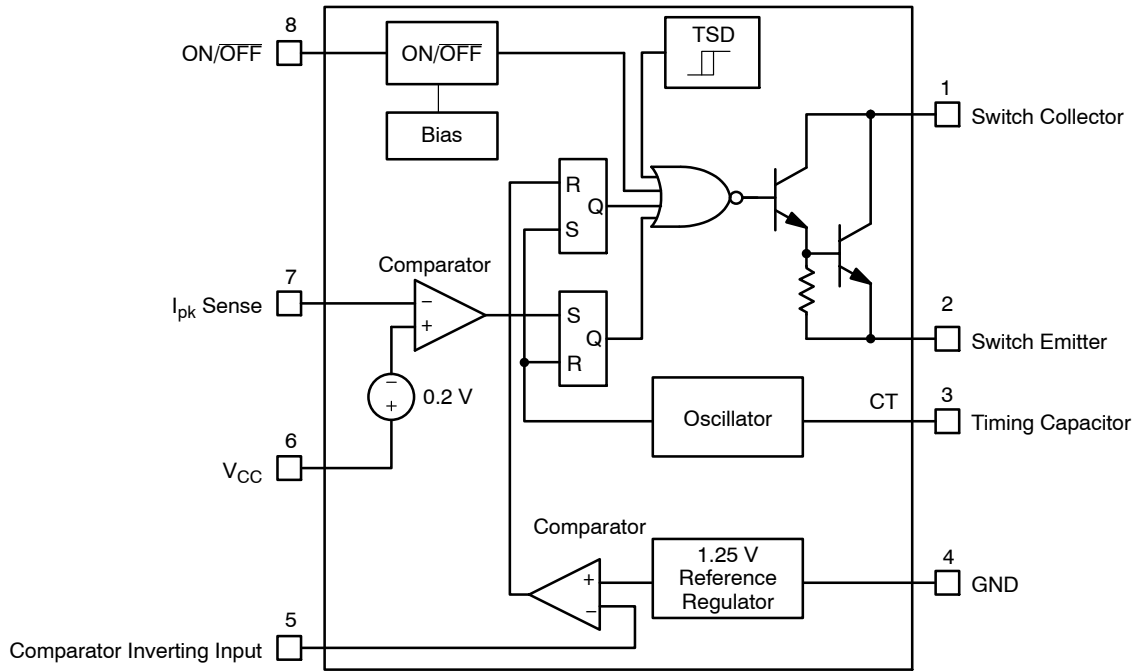

Figure 4. Block Diagram

PIN DESCRIPTION

Pin No.	Pin Name	Description
1	Switch Collector	Internal Darlington switch collector
2	Switch Emitter	Internal Darlington switch emitter
3	Timing Capacitor	Timing Capacitor Oscillator Input, Timing Capacitor
4	GND	Ground pin for all internal circuits
5	Comparator Inverting Input	Inverting input pin of internal comparator
6	V _{CC}	Voltage supply
7	I _{pk} Sense	Peak Current Sense Input to monitor the voltage drop across an external resistor to limit the peak current through the circuit
8	ON/OFF	ON/OFF Pin. Pulling this pin to High level turns the device in Operating. To switch into mode with low current consumption this pin has to be in Low level or floating.

NCP3064, NCP3064B, NCV3064

MAXIMUM RATINGS (measured vs. Pin 4, unless otherwise noted)

RATING	SYMBOL	VALUE	UNIT
V _{CC} (Pin 6)	V _{CC}	-0.3 to 42	V
Comparator Inverting Input (Pin 5)	V _{CI}	-0.3 to V _{CC}	V
Darlington Switch Emitter (Pin 2) (Transistor OFF)	V _{SWE}	-0.6 to V _{CC}	V
Darlington Switch Collector (Pin 1)	V _{SWC}	-0.3 to 42	V
Darlington Switch Collector to Emitter (Pins 1 and 2)	V _{SWCE}	-0.3 to 42	V
Darlington Switch Peak Current	I _{SW}	1.5	A
I _{pk} Sense Voltage (Pin 7)	V _{IPK}	-0.3 to (V _{CC} + 0.3 V)	V
Timing Capacitor Pin Voltage (Pin 3)	V _{TC}	-0.2 to +1.4	V
Moisture Sensitivity Level	MSL	1	
Lead Temperature Soldering Reflow (SMD Styles Only), Pb-Free Versions	T _{SLD}	260	°C
ON/OFF Pin Voltage	V _{ON/OFF}	(-0.3 to 25) < V _{CC}	V

Stresses exceeding Maximum Ratings may damage the device. Maximum Ratings are stress ratings only. Functional operation above the Recommended Operating Conditions is not implied. Extended exposure to stresses above the Recommended Operating Conditions may affect device reliability.

THERMAL CHARACTERISTIC

Rating	Symbol	Value	Unit	
PDIP-8 (Note 5) Thermal Resistance Junction-to-Air	R _{θJA}	100	°C/W	
SOIC-8 (Note 5)	Thermal Resistance Junction-to-Air	R _{θJA}	180	°C/W
	Thermal Resistance Junction-to-Case	R _{θJC}	45	
DFN-8 (Note 5)	Thermal Resistance Junction-to-Air	R _{θJA}	78	°C/W
	Thermal Resistance Junction-to-Case	R _{θJC}	14	
Storage temperature range	T _{STG}	-65 to +150	°C	
Maximum junction temperature	T _{J MAX}	+150	°C	
Operation Junction Temperature Range (Note 3)	T _J	0 to +70 -40 to +125	°C	

- This device series contains ESD protection and exceeds the following tests:
Pins 1 through 8:
Human Body Model 2000 V per AEC Q100-002; 003 or JESD22/A114; A115
Machine Model Method 200 V
- This device contains latch-up protection and exceeds 100 mA per JEDEC Standard JESD78.
- The relation between junction temperature, ambient temperature and Total Power dissipated in IC is $T_J = T_A + R_{\theta} \cdot P_D$.
- The pins which are not defined may not be loaded by external signals.
- 1 oz copper, 1 in² copper area.

NCP3064, NCP3064B, NCV3064

ELECTRICAL CHARACTERISTICS ($V_{CC} = 5.0\text{ V}$, $-40^{\circ}\text{C} < T_J < +125^{\circ}\text{C}$ for NCP3064B and NCV3064, $0^{\circ}\text{C} < T_J < +70^{\circ}\text{C}$ for NCP3064 unless otherwise specified)

Symbol	Characteristic	Conditions	Min	Typ	Max	Unit
--------	----------------	------------	-----	-----	-----	------

OSCILLATOR

f_{OSC}	Frequency	($V_{Pin\ 5} = 0\text{ V}$, $C_T = 2.2\text{ nF}$, $T_J = 25^{\circ}\text{C}$)	110	150	190	kHz
I_{DISCHG} / I_{CHG}	Discharge to Charge Current Ratio	(Pin 7 to V_{CC} , $T_J = 25^{\circ}\text{C}$)	5.5	6.0	6.5	–
I_C	Capacitor Charging Current	(Pin 7 to V_{CC} , $T_J = 25^{\circ}\text{C}$)		275		μA
I_{DISCH}	Capacitor Discharging Current	(Pin 7 to V_{CC} , $T_J = 25^{\circ}\text{C}$)		1.65		mA
V_{IPK}	Current Limit Sense Voltage	($T_J = 25^{\circ}\text{C}$)	165	200	235	mV

OUTPUT SWITCH (Note 6)

V_{SWCE}	Darlington Switch Collector to Emitter Voltage Drop	($I_{SW} = 1.0\text{ A}$, $T_J = 25^{\circ}\text{C}$) (Note 6)		1.0	1.3	V
$I_{C(OFF)}$	Collector Off-State Current	($V_{CE} = 40\text{ V}$)		1.0	10	μA

COMPARATOR

V_{TH}	Threshold Voltage	$T_J = 25^{\circ}\text{C}$		1.25		V
		NCP3064	-1.5		+1.5	%
		NCP3064B, NCV3064	-1.5		+1.5	%
REG_{LINE}	Threshold Voltage Line Regulation	($V_{CC} = 3.0\text{ V to }40\text{ V}$)	-6.0	2.0	6.0	mV
$I_{CII\ in}$	Input Bias Current	($V_{in} = V_{th}$)	-1000	-100	1000	nA

ON/OFF FEATURE

V_{IH}	ON/OFF Pin Logic Input Level High $V_{OUT} = \text{Nominal Output Voltage}$	$T_J = 25^{\circ}\text{C}$	2.2	–	–	V
		$T_J = -40^{\circ}\text{C to }+125^{\circ}\text{C}$	2.4	–	–	
V_{IL}	ON/OFF Pin Logic Input Level Low $V_{OUT} = 0\text{ V}$	$T_J = 25^{\circ}\text{C}$	–	–	1.0	V
		$T_J = -40^{\circ}\text{C to }+125^{\circ}\text{C}$	–	–	0.8	
I_{IH}	ON/OFF Pin Input Current ON/OFF Pin = 5 V (ON)	$T_J = 25^{\circ}\text{C}$		15		μA
I_{IL}	ON/OFF Pin Input Current ON/OFF Pin = 0 V (OFF)	$T_J = 25^{\circ}\text{C}$		1.0		μA

TOTAL DEVICE

I_{CC}	Supply Current	($V_{CC} = 5.0\text{ V to }40\text{ V}$, $C_T = 2.2\text{ nF}$, Pin 7 = V_{CC} , $V_{Pin\ 5} > V_{th}$, Pin 2 = GND, remaining pins open)			7.0	mA
I_{STBY}	Standby Quiescent Current	ON/OFF Pin = 0 V (OFF) $T_J = 25^{\circ}\text{C}$ $T_J = -40^{\circ}\text{C to }+125^{\circ}\text{C}$		85	100 100	μA
T_{SHD}	Thermal Shutdown Threshold			160		$^{\circ}\text{C}$
T_{SHDHYS}	Hysteresis			10		$^{\circ}\text{C}$

- Low duty cycle pulse techniques are used during test to maintain junction temperature as close to ambient temperature as possible.
- The V_{IPK} (Sense) Current Limit Sense Voltage is specified at static conditions. In dynamic operation the sensed current turn-off value depends on comparator response time and di/dt current slope. See the Operating Description section for details.

NCP3064, NCP3064B, NCV3064

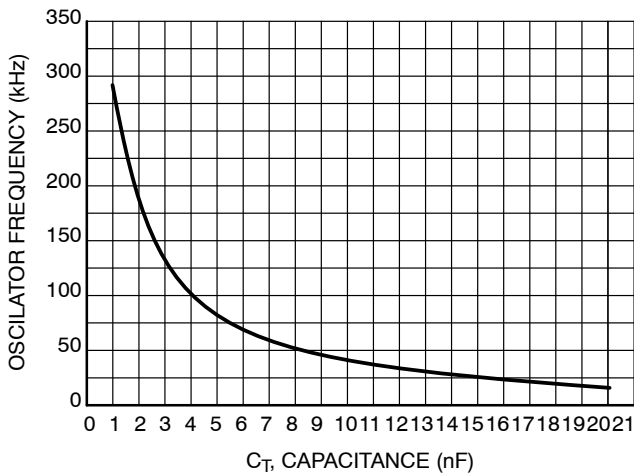

Figure 5. Oscillator Frequency vs. Timing Capacitor C_T

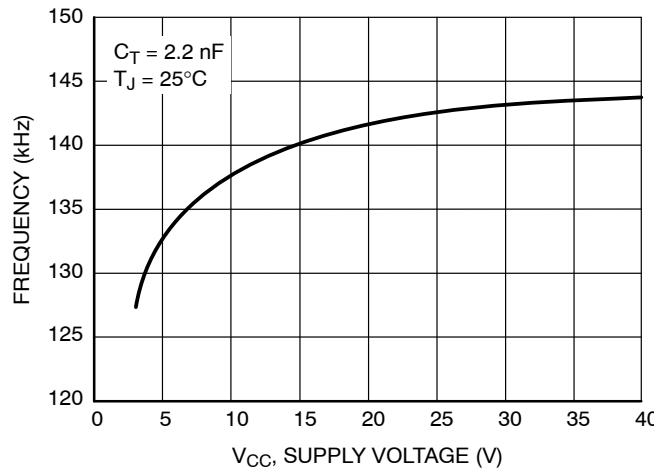

Figure 6. Oscillator Frequency vs. Supply Voltage

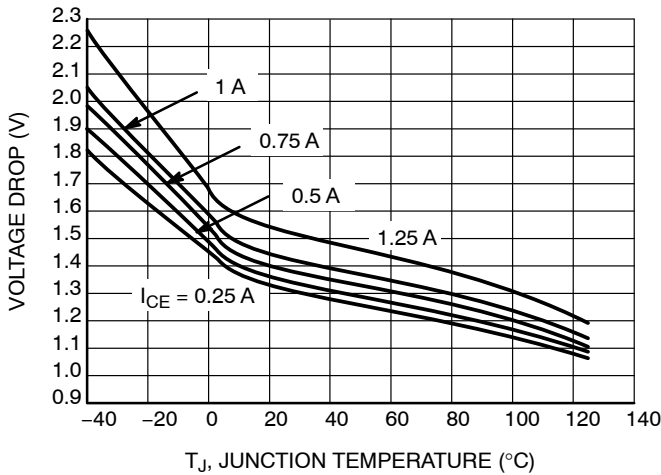

Figure 7. Emitter Follower Configuration Output Darlington Switch Voltage Drop vs. Temperature

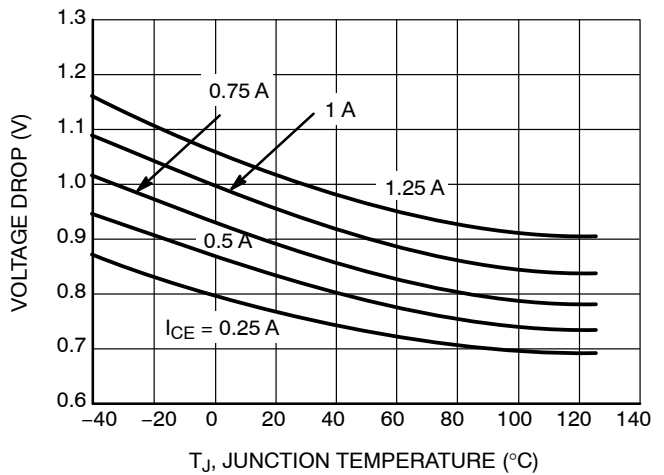

Figure 8. Common Emitter Configuration Output Darlington Switch Voltage Drop vs. Temperature

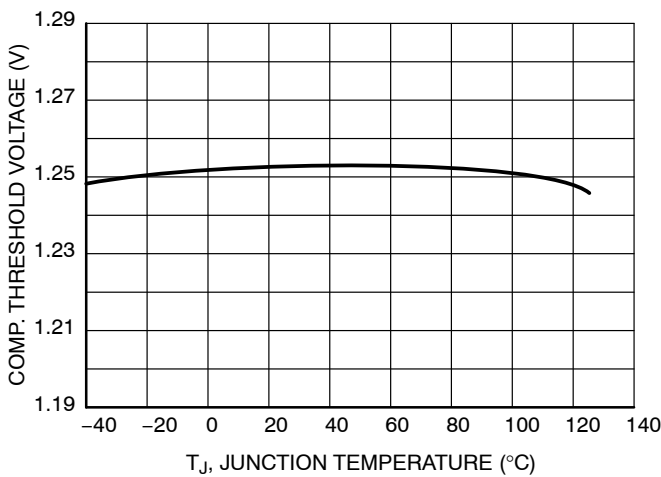

Figure 9. Comparator Threshold Voltage vs. Temperature

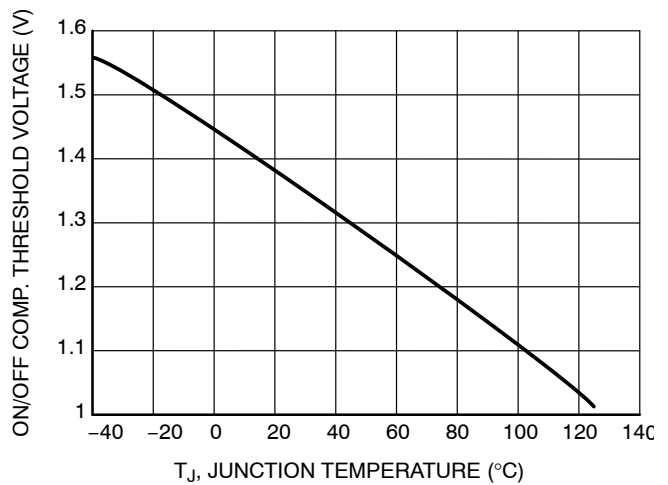

Figure 10. ON/OFF Comparator Threshold Voltage vs. Temperature

NCP3064, NCP3064B, NCV3064

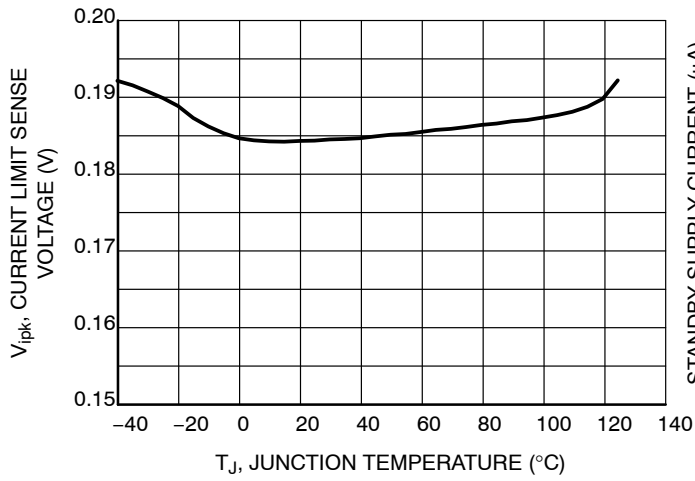

Figure 11. Current Limit Sense Voltage vs. Temperature

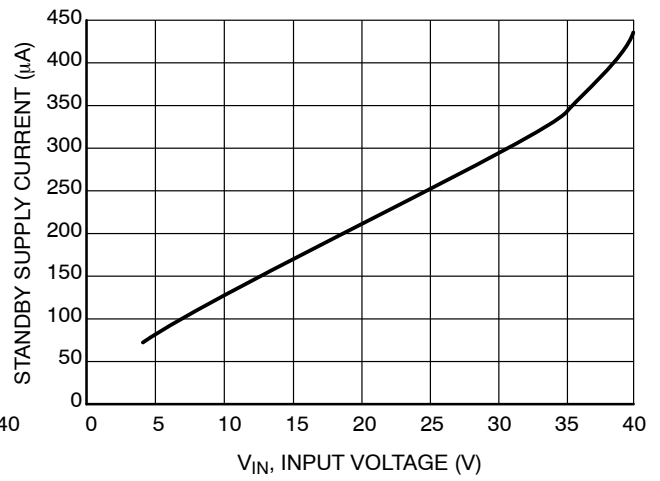

Figure 12. Standby Current vs. Supply Voltage

INTRODUCTION

The NCP3064 is a monolithic power switching regulator optimized for dc to dc converter applications. The combination of its features enables the system designer to directly implement step-up, step-down, and voltage-inverting converters with a minimum number of external components. Potential applications include cost sensitive consumer products as well as equipment for industrial markets. A representative block diagram is shown in Figure 4.

Operating Description

The NCP3064 is a hysteric, dc-dc converter that uses a gated oscillator to regulate output voltage. In general, this mode of operation is some what analogous to a capacitor charge pump and does not require dominant pole loop compensation for converter stability. The Typical Operating Waveforms are shown in Figure 13. The output voltage waveform shown is for a step-down converter with the ripple and phasing exaggerated for clarity. During initial converter startup, the feedback comparator senses that the output voltage level is below nominal. This causes the output switch to turn on and off at a frequency and duty cycle controlled by the oscillator, thus pumping up the output filter

capacitor. When the output voltage level reaches nominal, the output switch next cycle turning on is inhibited. The feedback comparator will enable the switching immediately when the load current causes the output voltage to fall below nominal. Under these conditions, output switch conduction can be enabled for a partial oscillator cycle, a partial cycle plus a complete cycle, multiple cycles, or a partial cycle plus multiple cycles.

Oscillator

The oscillator frequency and off-time of the output switch are programmed by the value selected for the timing capacitor C_T . Capacitor C_T is charged and discharged by a 1 to 6 ratio internal current source and sink, generating a positive going sawtooth waveform at Pin 3. This ratio sets the maximum $t_{ON}/(t_{ON} + t_{OFF})$ of the switching converter as $6/(6 + 1)$ or 0.857 (typical).

The oscillator peak and valley voltage difference is 500 mV typically. To calculate the C_T capacitor value for the required oscillator frequency, use the equation found in Figure 15. An Excel® based design tool can be found at www.onsemi.com on the NCP3064 product page.

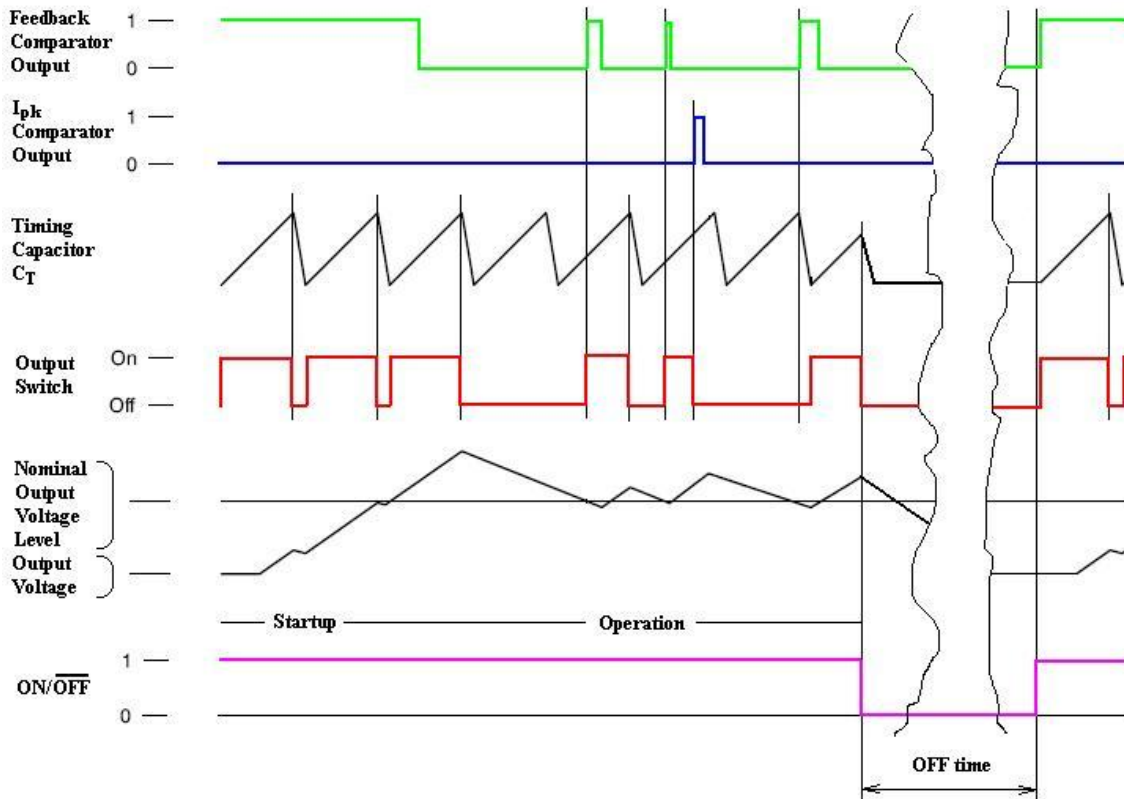

Peak Current Sense Comparator

With a voltage ripple gated converter operating under normal conditions, output switch conduction is initiated by the Voltage Feedback comparator and terminated by the oscillator. Abnormal operating conditions occur when the converter output is overloaded or when feedback voltage sensing is lost. Under these conditions, the I_{pk} Current Sense comparator will protect the Darlington output Switch. The switch current is converted to a voltage by inserting a fractional Ω resistor, R_{SC}, in series with V_{CC} and the Darlington output switch. The voltage drop across R_{SC} is monitored by the Current Sense comparator. If the voltage drop exceeds 200 mV with respect to V_{CC}, the comparator will set the latch and terminate output switch conduction on a cycle-by-cycle basis. This Comparator/Latch configuration ensures that the Output Switch has only a single on-time during a given oscillator cycle.

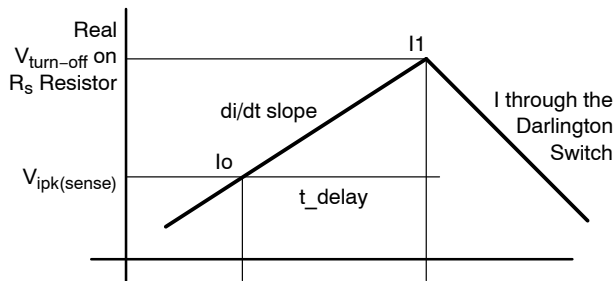

Figure 14. Current Sense Waveform

The V_{IPK(Sense)} Current Limit Sense Voltage threshold is specified at static conditions. In dynamic operation the sensed current turn-off value depends on comparator response time and di/dt current slope.

Real V_{turn-off} on R_{SC} resistor

$$V_{turn-off} = V_{ipk(sense)} + R_S * (t_{delay} * di/dt)$$

Typical I_{pk} comparator response time t_{delay} is 350 ns. The di/dt current slope is growing with voltage difference on the

inductor pins and with decreasing inductor value. It is recommended to check the real max peak current in the application at worst conditions to be sure that the maximum peak current will never get over the 1.5 A Darlington Switch Current maximum rating.

Thermal Shutdown

Internal thermal shutdown circuitry is provided to protect the IC in the event that the maximum junction temperature is exceeded. When activated, typically at 160°C, the Output Switch is disabled. The temperature sensing circuit is designed with 10°C hysteresis. The Switch is enabled again when the chip temperature decreases to at least 150°C threshold. This feature is provided to prevent catastrophic failures from accidental device overheating. It is not intended to be used as a replacement for proper heat-sinking.

Output Switch

The output switch is designed in a Darlington configuration. This allows the application designer to operate at all conditions at high switching speed and low voltage drop. The Darlington Output Switch is designed to switch a maximum of 40 V collector to emitter voltage and current up to 1.5 A

ON/OFF Function

The ON/OFF function disables switching and puts the part into a low power consumption mode. A PWM signal up to 1 kHz can be used to pulse the ON/OFF and control the output. Pulling this pin below the threshold voltage (~1.4 V) or leaving it open turns the regulator off and has a standby current <100 μA. Pulling this pin above 1.4 V (up to 25 V max) allows the regulator to run in normal operation. If the ON/OFF feature is not needed, the ON/OFF pin can be connected to the input voltage V_{CC}, provided that this voltage does not exceed 25 V.

APPLICATIONS

Figures 16, 20 and 24 show the simplicity and flexibility of the NCP3064. Two main converter topologies are demonstrated with actual test data shown below the circuit diagrams.

Figure 15 gives the relevant design equations for the key parameters. Additionally, a complete application design aid for the NCP3064 can be found at www.onsemi.com.

It is possible to create applications with external transistors. This solution helps to increase output current and helps with efficiency, still keeping the cost of materials low. Another advantage of using the external transistor is higher operating frequency, which can go up to 250 kHz. Smaller size of the output components such as inductor and capacitor can be used then.

(See Notes 8, 9, 10)	Step-Down	Step-Up	Voltage-Inverting
$\frac{t_{on}}{t_{off}}$	$\frac{V_{out} + V_F}{V_{in} - V_{SWCE} - V_{out}}$	$\frac{V_{out} + V_F - V_{in}}{V_{in} - V_{SWCE}}$	$\frac{ V_{out} + V_F}{V_{in} - V_{SWCE}}$
t_{on}	$\frac{t_{on}}{t_{off}}$ $f \left(\frac{t_{on}}{t_{off}} + 1 \right)$	$\frac{t_{on}}{t_{off}}$ $f \left(\frac{t_{on}}{t_{off}} + 1 \right)$	$\frac{t_{on}}{t_{off}}$ $f \left(\frac{t_{on}}{t_{off}} + 1 \right)$
C_T	$C_T = \frac{381.6 \cdot 10^{-6}}{f_{osc}} - 343 \cdot 10^{-12}$		
$I_{L(avg)}$	I_{out}	$I_{out} \left(\frac{t_{on}}{t_{off}} + 1 \right)$	$I_{out} \left(\frac{t_{on}}{t_{off}} + 1 \right)$
$I_{pk (Switch)}$	$I_{L(avg)} + \frac{\Delta I_L}{2}$	$I_{L(avg)} + \frac{\Delta I_L}{2}$	$I_{L(avg)} + \frac{\Delta I_L}{2}$
R_{SC}	$\frac{0.20}{I_{pk (Switch)}}$	$\frac{0.20}{I_{pk (Switch)}}$	$\frac{0.20}{I_{pk (Switch)}}$
L	$\left(\frac{V_{in} - V_{SWCE} - V_{out}}{\Delta I_L} \right) t_{on}$	$\left(\frac{V_{in} - V_{SWCE}}{\Delta I_L} \right) t_{on}$	$\left(\frac{V_{in} - V_{SWCE}}{\Delta I_L} \right) t_{on}$
$V_{ripple(pp)}$	$\Delta I_L \sqrt{\left(\frac{1}{8 f C_O} \right)^2 + (ESR)^2}$	$\approx \frac{t_{on} I_{out}}{C_O} + \Delta I_L \cdot ESR$	$\approx \frac{t_{on} I_{out}}{C_O} + \Delta I_L \cdot ESR$
V_{out}	$V_{TH} \left(\frac{R_1}{R_2} + 1 \right)$	$V_{TH} \left(\frac{R_1}{R_2} + 1 \right)$	$V_{TH} \left(\frac{R_1}{R_2} + 1 \right)$

- 8. V_{SWCE} – Darlingon Switch Collector to Emitter Voltage Drop, refer to Figures 7, 5, 8 and 9.
- 9. V_F – Output rectifier forward voltage drop. Typical value for 1N5819 Schottky barrier rectifier is 0.4 V.
- 10. The calculated t_{on}/t_{off} must not exceed the minimum guaranteed oscillator charge to discharge ratio.

Figure 15. Design Equations

The Following Converter Characteristics Must Be Chosen:

V_{in} – Nominal operating input voltage.

V_{out} – Desired output voltage.

I_{out} – Desired output current.

ΔI_L – Desired peak-to-peak inductor ripple current. For maximum output current it is suggested that ΔI_L be chosen to be less than 10% of the average inductor current $I_{L(avg)}$. This will help prevent $I_{pk(Switch)}$ from reaching the current limit threshold set by R_{SC} . If the design goal is to use a minimum inductance value, let $\Delta I_L = 2(I_{L(avg)})$. This will proportionally reduce converter output current capability.

f – Maximum output switch frequency.

$V_{ripple(pp)}$ – Desired peak-to-peak output ripple voltage. For best performance the ripple voltage should be kept to a low value since it will directly affect line and load regulation. Capacitor C_O should be a low equivalent series resistance (ESR) electrolytic designed for switching regulator applications.

NCP3064, NCP3064B, NCV3064

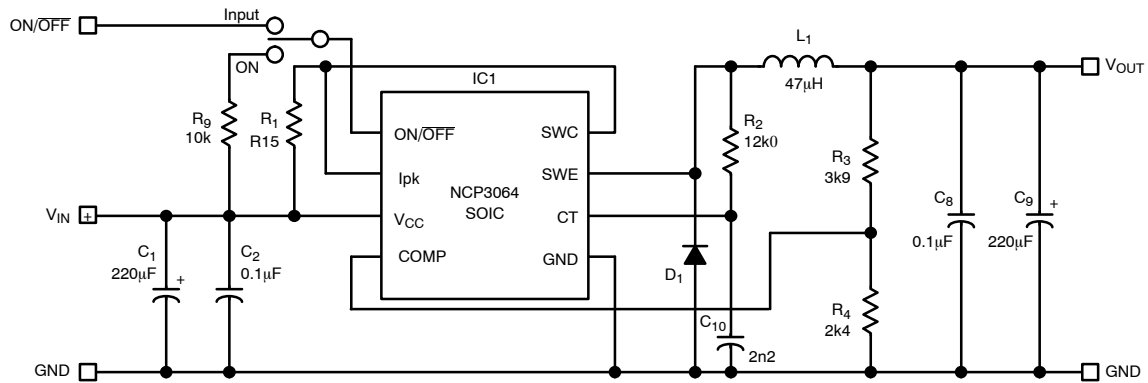

Figure 16. Typical Buck Application Schematic

Table 1. TESTED PARAMETERS

Parameter	Input Voltage (V)	Output Voltage (V)	Input Current (A)	Output Current (A)
Value	10 – 16	3.3	Max. 0.6 A	Max. 1.25

Table 2. BILL OF MATERIAL

Designator	Qty	Description	Value	Tolerance	Footprint	Manufacturer	Manufacturer Part Number
R1	1	Resistor	0.15Ω	1%	1206	Susumu	RL1632R-R150-F
R2	1	Resistor	12k	1%	1206	ROHM	MCR18EZH1202
R3	1	Resistor	3k9	1%	1206	ROHM	MCR18EZH3901
R4	1	Resistor	2k4	1%	1206	ROHM	MCR18EZH4701
R9	1	Resistor	10k	1%	1206	ROHM	MCR18EZH1002
C1	1	Capacitor	220µF/35V	20%	F	PANASONIC	EEEF1V221AP
C2, C8	2	Capacitor	100nF	10%	1206	Kemet	C1206C104K5RACTU
C9	1	Capacitor	220µF/6V	20%	F8	SANYO	6SVP220M
C10	1	Capacitor	2.2nF	10%	1206	Kemet	C1206C222K5RACTU
L1	1	Inductor	47µH	20%	DO3316	CoilCraft	DO3316P-473MLB
D1	1	Diode	MBRS230	-	SMB	ON Semiconductor	MBRS230LT3G
IC	1	Switching Regulator	NCP3064	-	SOIC8	ON Semiconductor	NCP3064DR2G

NCP3064, NCP3064B, NCV3064

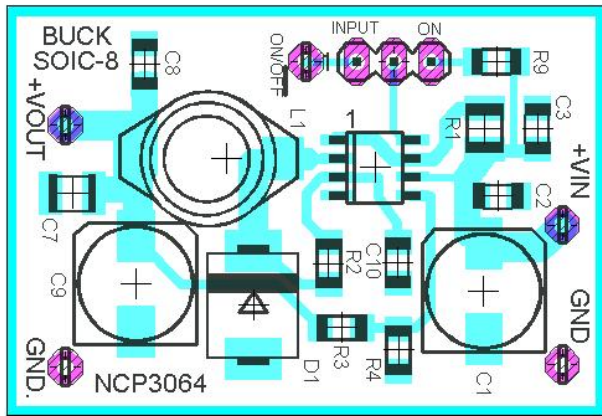

Figure 17. Buck Demoboard Layout

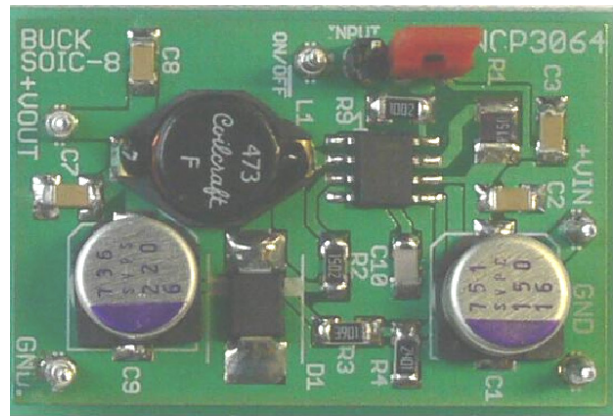

Figure 18. Buck Demoboard Photo

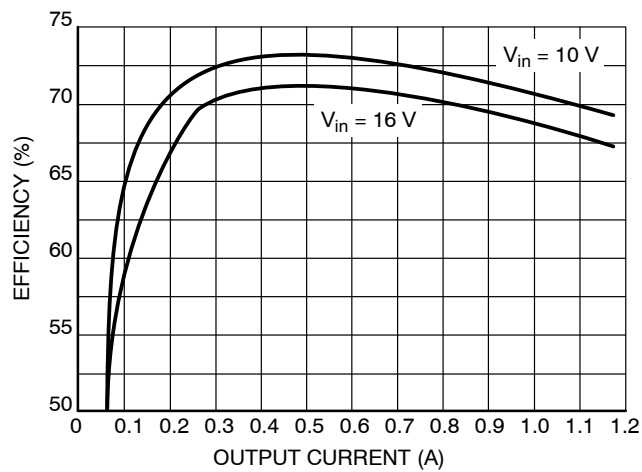

Figure 19. Efficiency vs. Output Current for Buck Demoboard

Table 3. TEST RESULTS

Line Regulation	$V_{in} = 9\text{ V to }12\text{ V}, V_{out} = 3.3\text{ V}, I_{out} = 800\text{ mA}$	8 mV
Load Regulation	$V_{in} = 12\text{ V}, V_{out} = 3.3\text{ V}, I_{out} = 800\text{ mA}$	10 mV
Output Ripple	$V_{in} = 12\text{ V}, V_{out} = 3.3\text{ V}, I_{out} = 100\text{ mA to }800\text{ mA}$	< 85 mV Peak - Peak
Efficiency	$V_{in} = 12\text{ V}, V_{out} = 3.3\text{ V}, I_{out} = 500\text{ mA}$	70%

NCP3064, NCP3064B, NCV3064

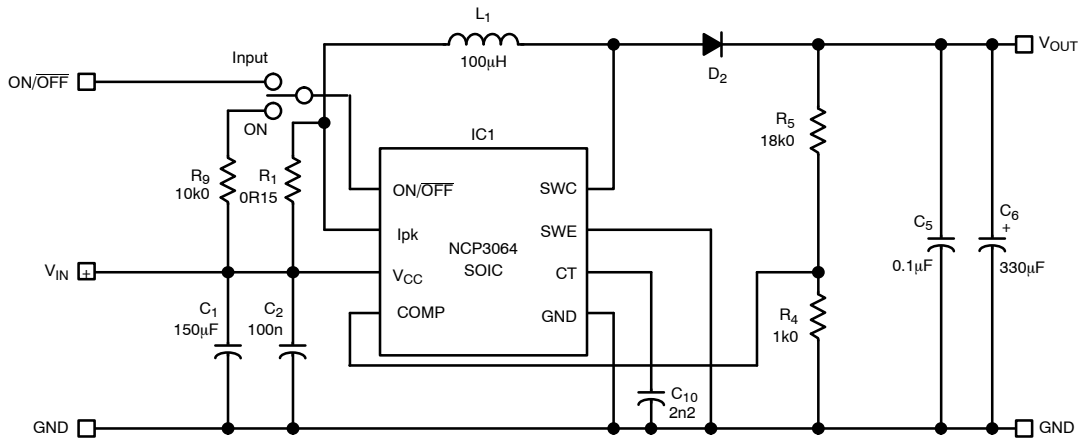

Figure 20. Typical Boost Application Schematic

Table 4. TESTED PARAMETERS

Parameter	Input Voltage (V)	Output Voltage (V)	Input Current (A)	Output Current (A)
Value	10 – 16	24	Max. 1.25	Max. 0.6

Table 5. BILL OF MATERIAL

Designator	Qty	Description	Value	Tolerance	Footprint	Manufacturer	Manufacturer Part Number
R1	1	Resistor	0.15Ω	1%	1206	Susumu	RL1632R-R150-F
R5	1	Resistor	18k	1%	1206	ROHM	MCR18EZH1802
R6	1	Resistor	1k	1%	1206	ROHM	MCR18EZH1001
R9	1	Resistor	10k	1%	1206	ROHM	MCR18EZH1002
C1	1	Capacitor	150μF/16V	20%	F8	SANYO	6SVP150M
C2, C5	2	Capacitor	100nF	10%	1206	Kemet	C1206C104K5RACTU
C6	1	Capacitor	330μF/25V	20%	SMD	Panasonic	EEE-FK1E331GP
C10	1	Capacitor	2.2nF	10%	1206	Kemet	C1206C222K5RACTU
L2	1	Inductor	100μH	20%	DO3316	CoilCraft	DO3316P-104MLB
D2	1	Diode	MBRS230	-	SMB	ON Semiconductor	MBRS230LT3G
IC	1	Switching Regulator	NCP3064	-	SOIC8	ON Semiconductor	NCP3064DR2G

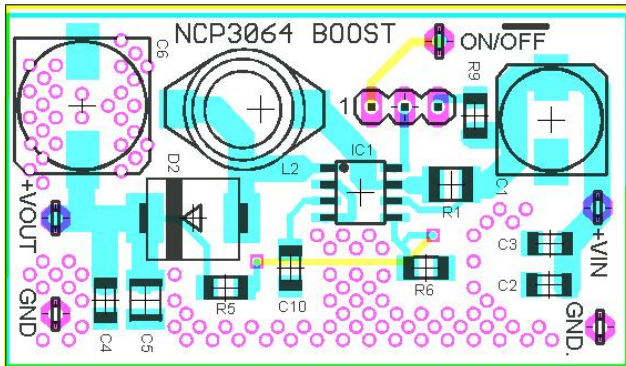

Figure 21. Boost Demoboard Layout

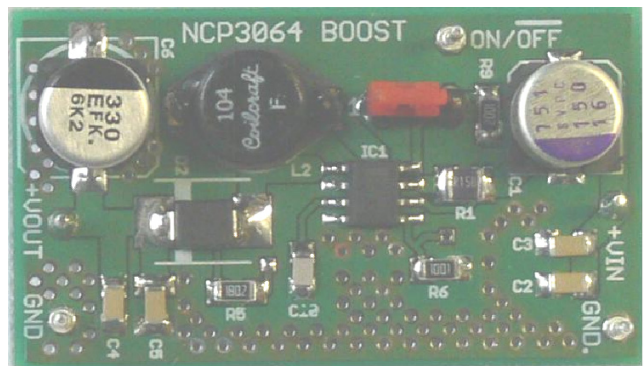

Figure 22. Boost Demoboard Photo

NCP3064, NCP3064B, NCV3064

Table 6. TEST RESULTS

Line Regulation	$V_{in} = 9\text{ V to }15\text{ V}, V_{out} = 24\text{ V}, I_{out} = 250\text{ mA}$	3 mV
Load Regulation	$V_{in} = 12\text{ V}, V_{out} = 24\text{ V}, I_{out} = 50\text{ to }350\text{ mA}$	5 mV
Output Ripple	$V_{in} = 12\text{ V}, V_{out} = 24\text{ V}, I_{out} = 50\text{ to }350\text{ mA}$	< 350 mV Peak - Peak
Efficiency	$V_{in} = 12\text{ V}, V_{out} = 24\text{ V}, I_{out} = 200\text{ mA}$	86%

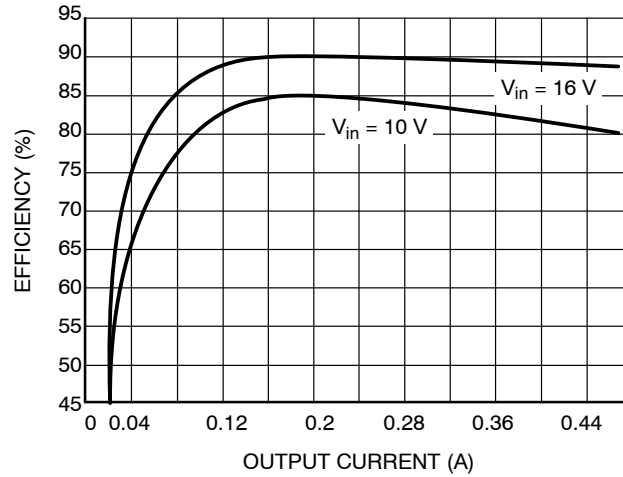

Figure 23. Efficiency vs. Output Current Current for Boost Demoboard

NCP3064, NCP3064B, NCV3064

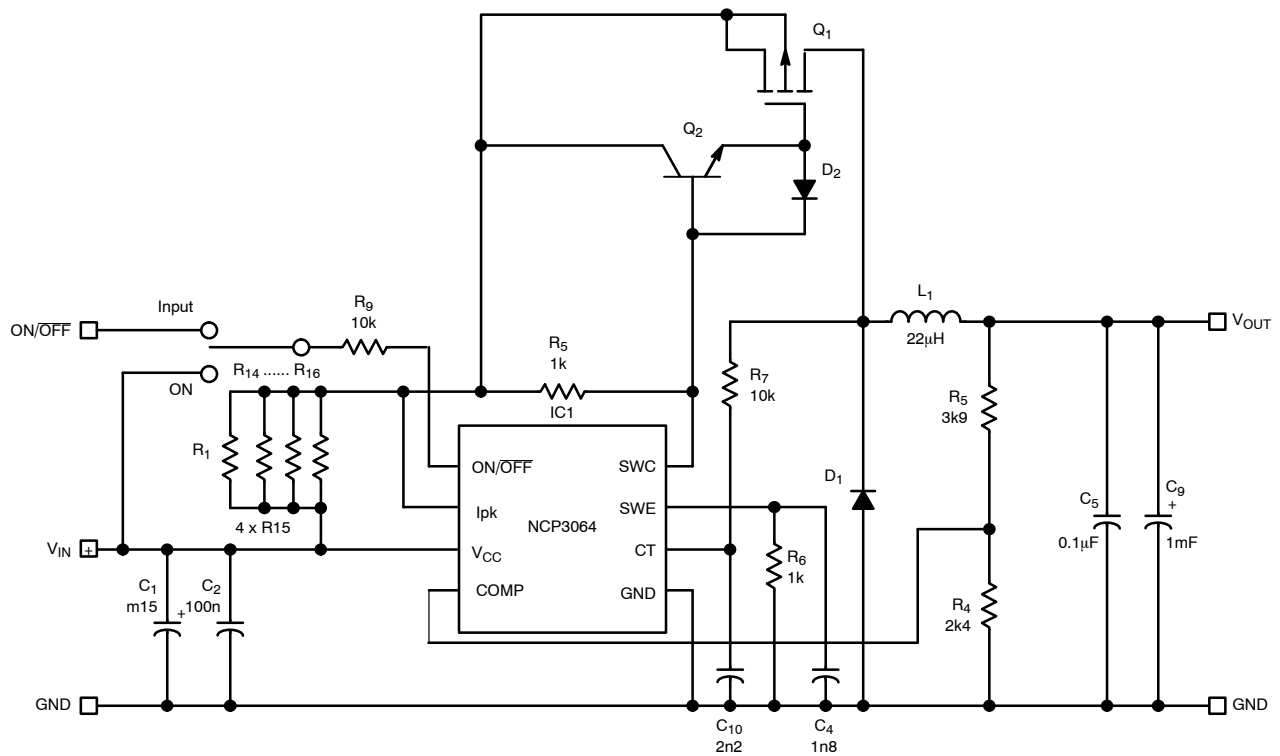

Figure 24. Typical Buck with External Transistor Application Schematic

Table 7. TESTED PARAMETERS

Parameter	Input Voltage (V)	Output Voltage (V)	Input Current (A)	Output Current (A)
Value	10 – 16	3.3	Max. 1.25	Max. 3

Table 8. BILL OF MATERIAL

Designator	Qty	Description	Value	Tolerance	Footprint	Manufacturer	Manufacturer Part Number
R1, R14, R15, R16	4	Resistor	0.15R	1%	1206	Susumu	RL1632R-R150-F
R5, R6	2	Resistor	1k	1%	1206	ROHM	MCR18EZHf1001
R3	1	Resistor	3k9	1%	1206	ROHM	MCR18EZHf3901
R4	1	Resistor	2k4	1%	1206	ROHM	MCR18EZHf2401
R7;R9	2	Resistor	10k	1%	1206	ROHM	MCR18EZHf1002
C1	1	Capacitor	270µF	20%	10 x 16	PANASONIC	EEUFC1V271
C4	1	Capacitor	1n8	10%	1206	Kemet	C1206C182K5RACTU
C2, C8	2	Capacitor	100nF	10%	1206	Kemet	C1206C104K5RACTU
C9	1	Capacitor	1mF	20%	F8	SANYO	4SA1000M
C10	1	Capacitor	2.2nF	10%	1206	Kemet	C1206C222K5RACTU
Q1	1	Transistor	MMSF7P03	-	SOIC8	ON Semiconductor	MMSF7P03HDR2G
Q2	1	Transistor NPN	MMBT489L	-	SOT-23	ON Semiconductor	MMBT489LT1G
D2	1	Diode	MBR130T	-	SOD-123	ON Semiconductor	MBR130T1G
IC1	1	Switching Regulator	NCP3064	-	SOIC8	ON Semiconductor	NCP3064DR2G
D1	1	Diode	MBRS330T	-	SMC	ON Semiconductor	MBRS330T3G
L1	1	Inductor	22µH	20%	Coilcraft	Coilcraft	DO5040H-223MLB

NCP3064, NCP3064B, NCV3064

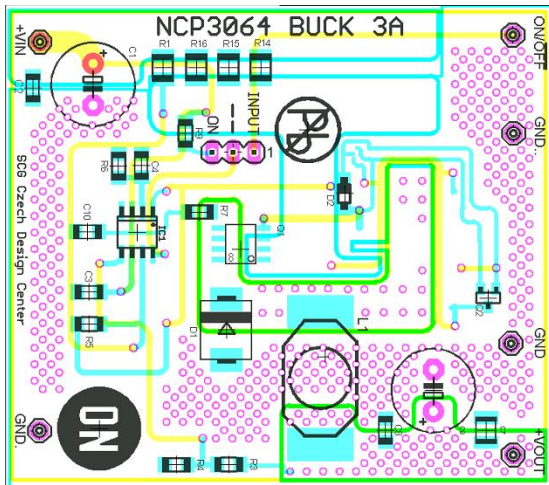

Figure 25. Buck Demoboard with External PMOS Transistor Layout

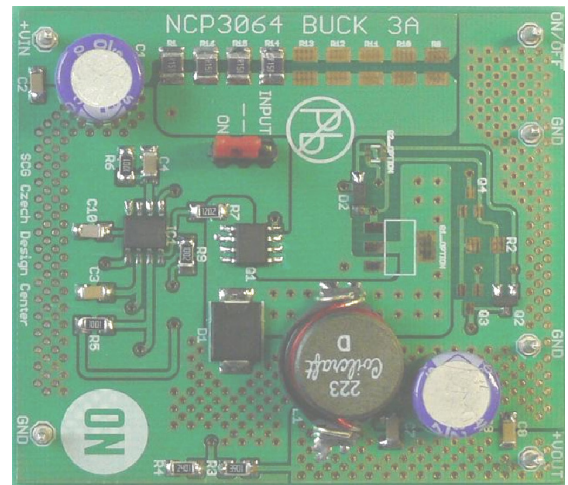

Figure 26. Buck Demoboard with External PMOS Transistor Photo

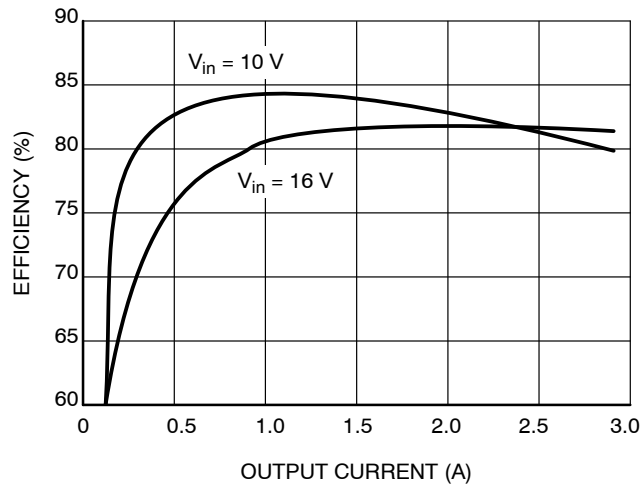

Figure 27. Efficiency vs. Output Current Current for Buck Demoboard with External PMOS Transistor

Table 9. TEST RESULTS

Line Regulation	$V_{in} = 9\text{ V to }15\text{ V}, V_{out} = 3.3\text{ V}, I_{out} = 2\text{ A}$	8 mV
Load Regulation	$V_{in} = 12\text{ V}, V_{out} = 3.3\text{ V}, I_{out} = 0.5\text{ to }3.0\text{ A}$	10 mV
Output Ripple	$V_{in} = 12\text{ V}, V_{out} = 3.3\text{ V}, I_{out} = 0.5\text{ to }3.0\text{ A}$	< 300 mV Peak - Peak
Efficiency	$V_{in} = 12\text{ V}, V_{out} = 3.3\text{ V}, I_{out} = 2\text{ A}$	82%

NCP3064, NCP3064B, NCV3064

The picture in Figure 24. Typical Buck Application Schematic shows typical configuration with external PMOS transistor. Resistor R7 connected between timing capacitor TC Pin and SWE Pin provides a pulse feedback voltage. The pulse feedback approach increases the operating frequency by up to 50%. Figure 28, Oscillator Frequency vs. Timing Capacitor with Pulse Feedback, shows the impact to the oscillator frequency at buck converter for $V_{in} = 12\text{ V}$ and $V_{out} = 3.3\text{ V}$ with pulse feedback resistor $R_7 = 10\text{ k}\Omega$. It also creates more regular switching waveforms with constant operating frequency which results in lower ripple voltage and improved efficiency.

If the application allows $\overline{\text{ON/OFF}}$ pin to be biased by voltage and the power supply is not connected to V_{CC} pin at the same time, then it is recommended to limit $\overline{\text{ON/OFF}}$ current by resistor with value $10\text{ k}\Omega$ to protect the NCP3064 device. This situation is mentioned in Figure 29, $\overline{\text{ON/OFF}}$ Serial Resistor Connection.

This resistor shifts the $\overline{\text{ON/OFF}}$ threshold by about 200 mV to higher value, but the TTL logic compatibility is kept in full range of input voltage and operating temperature range.

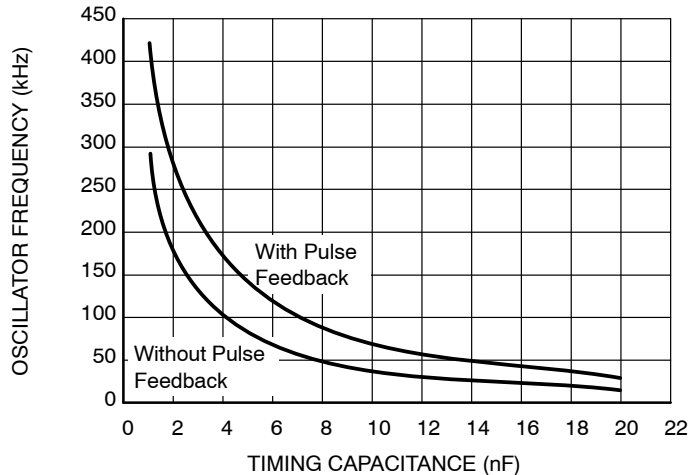

Figure 28. Oscillator Frequency vs. Timing Capacitor with Pulse Feedback

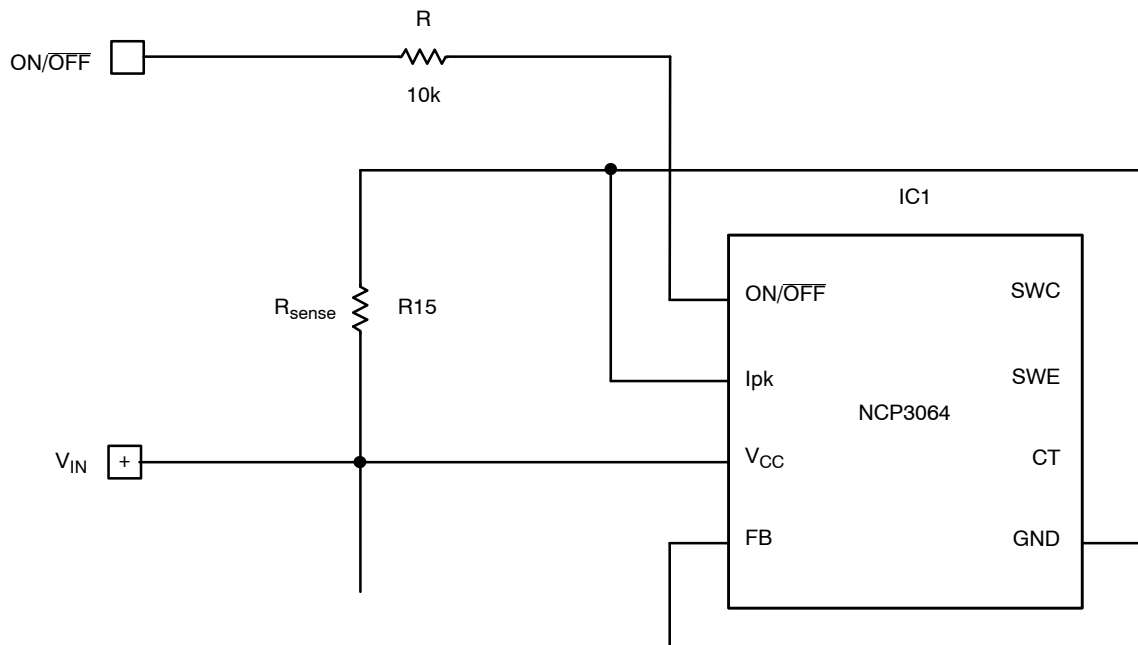

Figure 29. $\overline{\text{ON/OFF}}$ Serial Resistor Connection

NCP3064, NCP3064B, NCV3064

ORDERING INFORMATION

Device	Package	Shipping†
NCP3064MNTXG	DFN-8 (Pb-Free)	4000 Units / Tape & Reel
NCP3064BMNTXG	DFN-8 (Pb-Free)	4000 Units / Tape & Reel
NCP3064PG	PDIP-8 (Pb-Free)	50 Units / Rail
NCP3064BPG	PDIP-8 (Pb-Free)	50 Units / Rail
NCP3064DR2G	SOIC-8 (Pb-Free)	2500 Units / Tape & Reel
NCP3064BDR2G	SOIC-8 (Pb-Free)	2500 Units / Tape & Reel
NCV3064MNTXG	DFN-8 (Pb-Free)	4000 Units / Tape & Reel
NCV3064PG	PDIP-8 (Pb-Free)	50 Units / Rail
NCV3064DR2G	SOIC-8 (Pb-Free)	2500 Units / Tape & Reel

†For information on tape and reel specifications, including part orientation and tape sizes, please refer to our Tape and Reel Packaging Specifications Brochure, BRD8011/D.

NCP3064, NCP3064B, NCV3064

PACKAGE DIMENSIONS

8 LEAD PDIP
CASE 626-05
ISSUE L

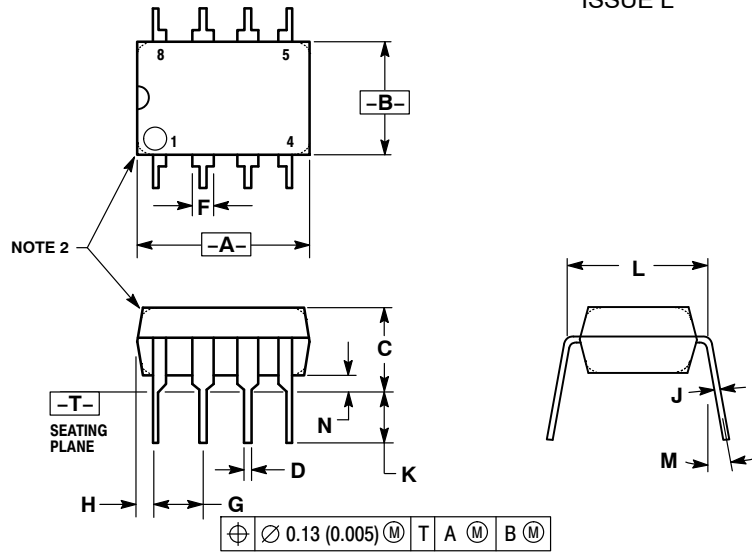

NOTES:

1. DIMENSION L TO CENTER OF LEAD WHEN FORMED PARALLEL.
2. PACKAGE CONTOUR OPTIONAL (ROUND OR SQUARE CORNERS).
3. DIMENSIONING AND TOLERANCING PER ANSI Y14.5M, 1982.

DIM	MILLIMETERS		INCHES	
	MIN	MAX	MIN	MAX
A	9.40	10.16	0.370	0.400
B	6.10	6.60	0.240	0.260
C	3.94	4.45	0.155	0.175
D	0.38	0.51	0.015	0.020
F	1.02	1.78	0.040	0.070
G	2.54 BSC		0.100 BSC	
H	0.76	1.27	0.030	0.050
J	0.20	0.30	0.008	0.012
K	2.92	3.43	0.115	0.135
L	7.62 BSC		0.300 BSC	
M	---	10°	---	10°
N	0.76	1.01	0.030	0.040

STYLE 1:

- PIN 1. AC IN
- DC + IN
- DC - IN
- AC IN
- GROUND
- OUTPUT
- AUXILIARY
- V_{CC}

NCP3064, NCP3064B, NCV3064

PACKAGE DIMENSIONS

SOIC-8 NB
CASE 751-07
ISSUE AJ

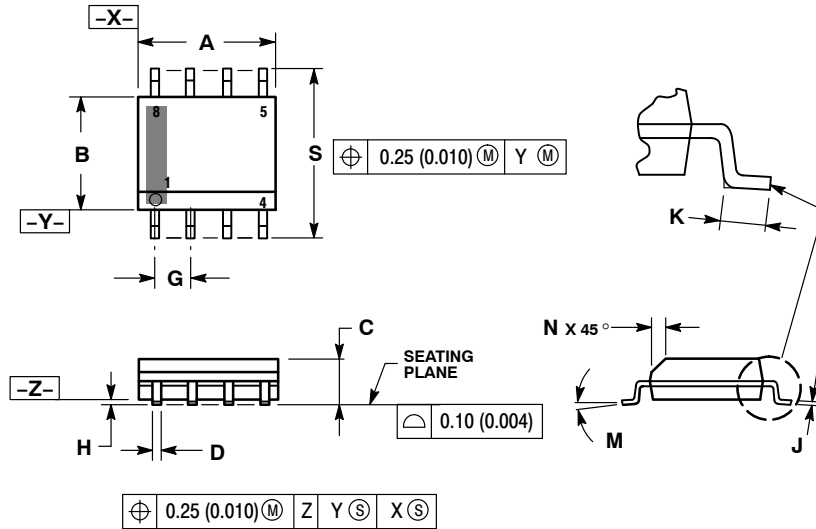

NOTES:

1. DIMENSIONING AND TOLERANCING PER ANSI Y14.5M, 1982.
2. CONTROLLING DIMENSION: MILLIMETER.
3. DIMENSION A AND B DO NOT INCLUDE MOLD PROTRUSION.
4. MAXIMUM MOLD PROTRUSION 0.15 (0.006) PER SIDE.
5. DIMENSION D DOES NOT INCLUDE DAMBAR PROTRUSION. ALLOWABLE DAMBAR PROTRUSION SHALL BE 0.127 (0.005) TOTAL IN EXCESS OF THE D DIMENSION AT MAXIMUM MATERIAL CONDITION.
6. 751-01 THRU 751-06 ARE OBSOLETE. NEW STANDARD IS 751-07.

DIM	MILLIMETERS		INCHES	
	MIN	MAX	MIN	MAX
A	4.80	5.00	0.189	0.197
B	3.80	4.00	0.150	0.157
C	1.35	1.75	0.053	0.069
D	0.33	0.51	0.013	0.020
G	1.27 BSC		0.050 BSC	
H	0.10	0.25	0.004	0.010
J	0.19	0.25	0.007	0.010
K	0.40	1.27	0.016	0.050
M	0°	8°	0°	8°
N	0.25	0.50	0.010	0.020
S	5.80	6.20	0.228	0.244

SOLDERING FOOTPRINT*

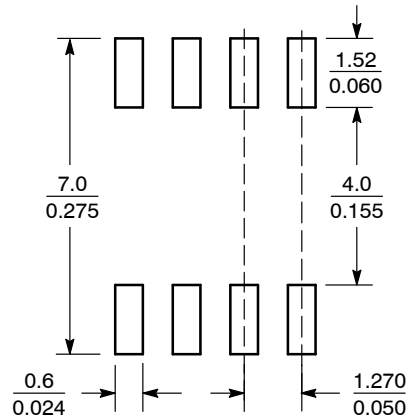

SCALE 6:1 $\left(\frac{\text{mm}}{\text{inches}}\right)$

*For additional information on our Pb-Free strategy and soldering details, please download the ON Semiconductor Soldering and Mounting Techniques Reference Manual, SOLDERRM/D.

NCP3064, NCP3064B, NCV3064

PACKAGE DIMENSIONS

8 PIN DFN, 4x4
CASE 488AF-01
ISSUE C

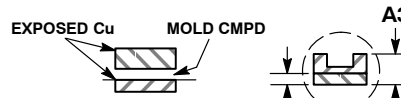
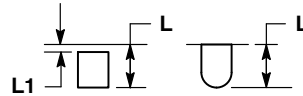
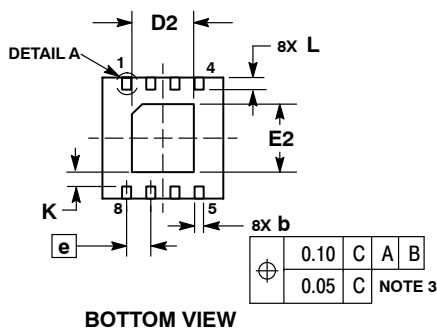
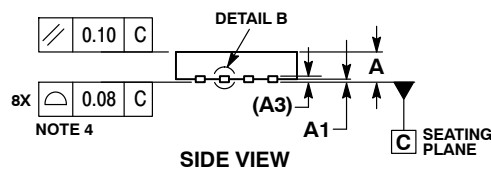
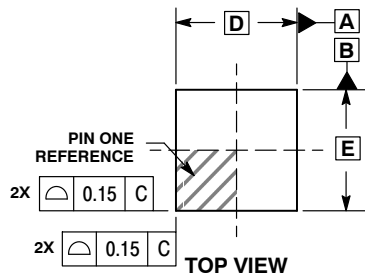

NOTES:

1. DIMENSIONS AND TOLERANCING PER ASME Y14.5M, 1994.
2. CONTROLLING DIMENSION: MILLIMETERS.
3. DIMENSION b APPLIES TO PLATED TERMINAL AND IS MEASURED BETWEEN 0.15 AND 0.30MM FROM TERMINAL TIP.
4. COPLANARITY APPLIES TO THE EXPOSED PAD AS WELL AS THE TERMINALS.
5. DETAILS A AND B SHOW OPTIONAL CONSTRUCTIONS FOR TERMINALS.

MILLIMETERS		
DIM	MIN	MAX
A	0.80	1.00
A1	0.00	0.05
A3	0.20	REF
b	0.25	0.35
D	4.00	BSC
D2	1.91	2.21
E	4.00	BSC
E2	2.09	2.39
e	0.80	BSC
K	0.20	---
L	0.30	0.50
L1	---	0.15

SOLDERING FOOTPRINT*

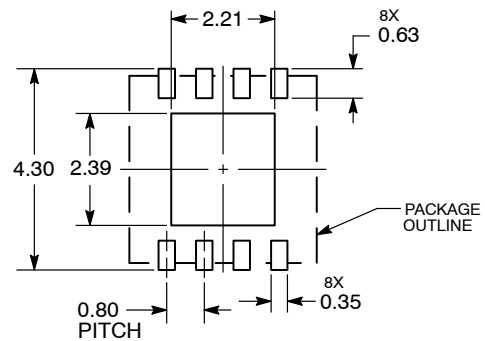

DIMENSIONS: MILLIMETERS

*For additional information on our Pb-Free strategy and soldering details, please download the ON Semiconductor Soldering and Mounting Techniques Reference Manual, SOLDERM/D.

Excel is a registered trademark of Microsoft Corporation.

ON Semiconductor and are registered trademarks of Semiconductor Components Industries, LLC (SCILLC). SCILLC reserves the right to make changes without further notice to any products herein. SCILLC makes no warranty, representation or guarantee regarding the suitability of its products for any particular purpose, nor does SCILLC assume any liability arising out of the application or use of any product or circuit, and specifically disclaims any and all liability, including without limitation special, consequential or incidental damages. "Typical" parameters which may be provided in SCILLC data sheets and/or specifications can and do vary in different applications and actual performance may vary over time. All operating parameters, including "Typicals" must be validated for each customer application by customer's technical experts. SCILLC does not convey any license under its patent rights nor the rights of others. SCILLC products are not designed, intended, or authorized for use as components in systems intended for surgical implant into the body, or other applications intended to support or sustain life, or for any other application in which the failure of the SCILLC product could create a situation where personal injury or death may occur. Should Buyer purchase or use SCILLC products for any such unintended or unauthorized application, Buyer shall indemnify and hold SCILLC and its officers, employees, subsidiaries, affiliates, and distributors harmless against all claims, costs, damages, and expenses, and reasonable attorney fees arising out of, directly or indirectly, any claim of personal injury or death associated with such unintended or unauthorized use, even if such claim alleges that SCILLC was negligent regarding the design or manufacture of the part. SCILLC is an Equal Opportunity/Affirmative Action Employer. This literature is subject to all applicable copyright laws and is not for resale in any manner.

PUBLICATION ORDERING INFORMATION

LITERATURE FULFILLMENT:
Literature Distribution Center for ON Semiconductor
P.O. Box 5163, Denver, Colorado 80217 USA
Phone: 303-675-2175 or 800-344-3860 Toll Free USA/Canada
Fax: 303-675-2176 or 800-344-3867 Toll Free USA/Canada
Email: orderlit@onsemi.com

N. American Technical Support: 800-282-9855 Toll Free USA/Canada
Europe, Middle East and Africa Technical Support:
Phone: 421 33 790 2910
Japan Customer Focus Center
Phone: 81-3-5773-3850

ON Semiconductor Website: www.onsemi.com
Order Literature: <http://www.onsemi.com/orderlit>
For additional information, please contact your local Sales Representative