



Designing with L6920DB, high efficiency
synchronous rectifier step-up converter

Introduction

The L6920DB is a high efficiency monolithic step-up switching converter IC especially designed for battery powered applications, thanks to its minimum start-up of 0.8 V, and a minimum operating voltage of 0.6 V.

It requires only three external components to realize the conversion from battery voltage to the selected output voltage.

It has a minimum output voltage of 1.8 V, which is enough to supply even the most advanced ASICs and microprocessors. The high switching frequency allows users to choose small inductors and output capacitors for their designs. Supervisory functions include Reference Voltage, Low Battery Detection, and Shutdown, which are provided with overcurrent protection.

Contents

1	Application information	3
1.1	Output voltage selection	4
1.2	Input capacitor selection	4
1.3	Output capacitor selection	4
1.4	Inductor selection	5
1.5	Switching frequency	5
1.6	Low battery detection	5
1.7	Layout guidelines	7
2	Typical performance	9
3	Revision history	10

1 Application information

Figure 1. L6920DB Example of overall application size

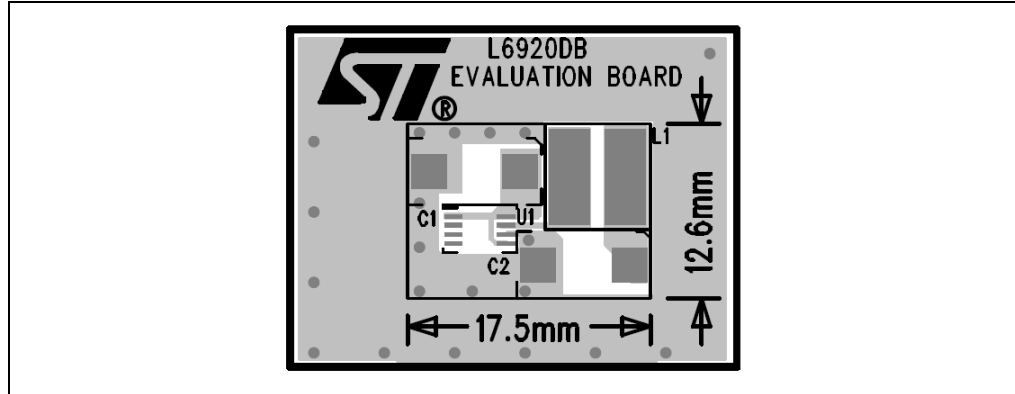

Figure 2. Application circuit

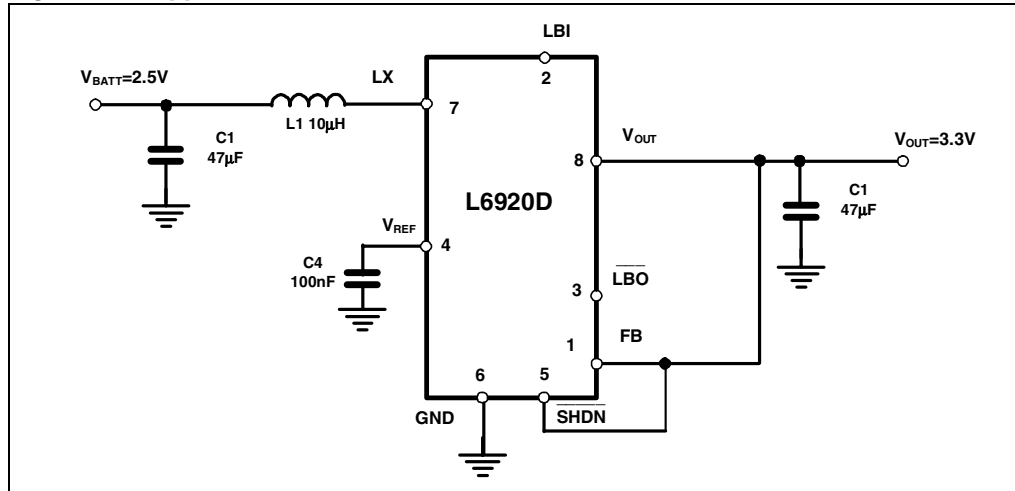
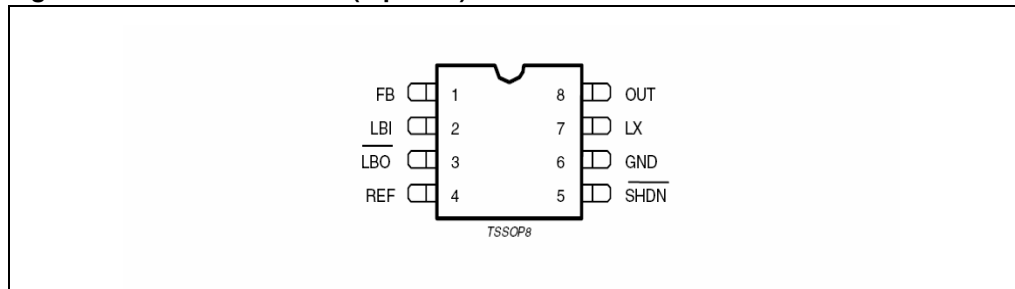

Figure 3. Pin connections (top view)



1.1 Output voltage selection

The output voltage must be selected by configuring the FB pin. Three choices are available:

- fixed 3.3 V
- fixed 5 V
- adjustable output set via an external resistor divider.

R4 and R5 should be selected in the range of 100 kΩ - 1 MΩ to minimize power consumption and errors due to current sunk by FB pin (a few nA). See [Figure 5](#)

Table 1. Output voltage connection

Output voltage	Feedback connection
$V_{OUT}=3.3\text{ V}$	FB Connected to OUT (See Figure 5)
$V_{OUT}=5\text{ V}$	FB Connected to GND (See Figure 5)
$1.8\text{ V}=V_{OUT}=5.2\text{ V}$	FB Connected to a resistor divider $V_{OUT} = 1.23\text{V} \cdot \left(1 + \frac{R4}{R5}\right)$

1.2 Input capacitor selection

A minimum capacitance is usually added at the input to filter the current ripple. 10 μF are enough for most of the applications.

Low-ESR Tantalum and Multilayer Ceramic Capacitors (MLCC) are good choices.

1.3 Output capacitor selection

The output capacitor affects both efficiency and output ripple, so its choice has to be considered with particular care. The capacitance value should be in the range of about 10mF-100 μF. An additional, smaller, low Equivalent Series Resistance (ESR) capacitor can be used (not mandatory) in parallel for high frequency filtering. A typical value is around 1 μF.

Note: For very high performance requirements (e.g., efficiency and output voltage ripple), a very low ESR capacitor has to be used (e.g. MLCC capacitors).

Other possibilities include low-ESR tantalum capacitors, available from KEMET, and other sources. POSCAP capacitors from SANYO and polymeric capacitors from PANASONIC are also good choices (see [Table 2](#)).

Note: The cap values and rated voltages are only suggested possibilities.

Table 2. Distributor's capacitor main list

Manufacturer	Series	Cap value (μF)	Rated voltage (V)	ESR (mΩ)
KEMET	T510/T494/ T495	10 to 47	6	30 to 100

Table 2. Distributor's capacitor main list (continued)

Manufacturer	Series	Cap value (μF)	Rated voltage (V)	ESR ($\text{m}\Omega$)
PANASONIC	EEFCD	22 to 47	6.3	50 to 700
SANYO POSCAP	TPA/B/C	22 to 230	6.3	40 to 80

1.4 Inductor selection

Usually, inductors ranging between 2 μH to 10 μH satisfy most application requirements. However, small-value inductors are physically smaller and guarantee a faster response to load transients.

Inductor size also affects the maximum current deliverable to the load. A low series resistance is suggested if very high efficiency values are needed. In any case, the saturation current of the choke should be higher than the peak current limit of the device (800 mA typ.). Good surface-mount inductors are available from COILCRAFTS, COILTRONICS and other sources (see [Table 3](#)).

Table 3. Distributor's inductor main list

Manufacturer	Series	Inductor value (μH)	Saturation current (A)
Coilcraft	LPO1704	2.2 to 10	0.9 to 1.6
	LPO6610	2.2 to 10	0.9 to 1.5
Coiltronics	SD10	2.2 to 6.2	0.9 to 1.6
	SD12	3.3 to 10	0.85 to 1.4
Panasonic	ELL6SH	10 to 22	0.9 to 1.5
	ELL6RH	5.1 to 10	1.1 to 1.55

1.5 Switching frequency

The control loop of the L6920DB is based on a Minimum OFF-time and a Maximum ON-time (see datasheet). This means that the switching frequency is not fixed, but changes in order to keep the output voltage regulated. The maximum reachable value is approximately 1MHz. The frequency value depends on the inductor value, input and output voltage, and the load.

1.6 Low battery detection

The L6920DB includes a low battery detection comparator. The threshold is V_{REF} voltage and a hysteresis is added to avoid oscillations when input crosses the threshold slowly. The Low Battery Output (LBO) is an open drain, so a pull-up resistor, R3, is required for proper use. Adding a resistor divider at the Low Battery Input (LBI) pin gives the user the ability to set at which value of V_{BATT} the (LBO) goes high. The relationship is showed below:

Equation 1

$$V_{\text{BATT-TH}} = 1.23\text{V} \cdot \left(1 + \frac{R1}{R2}\right)$$

If a Low battery voltage detection than 1.23 V is required, it is possible using a resistor divider between V_{OUT} and V_{BATT} , showed in the *Figure 4*.

In this case the relationship is the following:

Equation 2

$$V_{BATT-TH} = 1.23 - \left[\left(\frac{V_{OUT} - 1.23}{R2} \right) \cdot R1 \right]$$

In order to keep the efficiency high, the resistors of this divider must be chosen with a value higher than 100 K Ω

Figure 4. Schematic for low battery voltage detection below the 1.23 V voltage reference

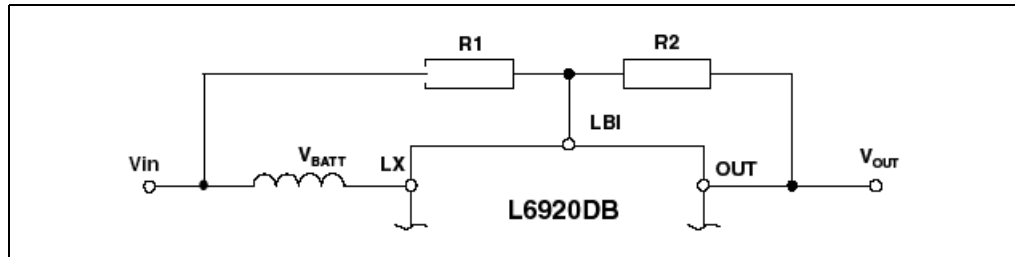

Figure 5. Demoboard schematic

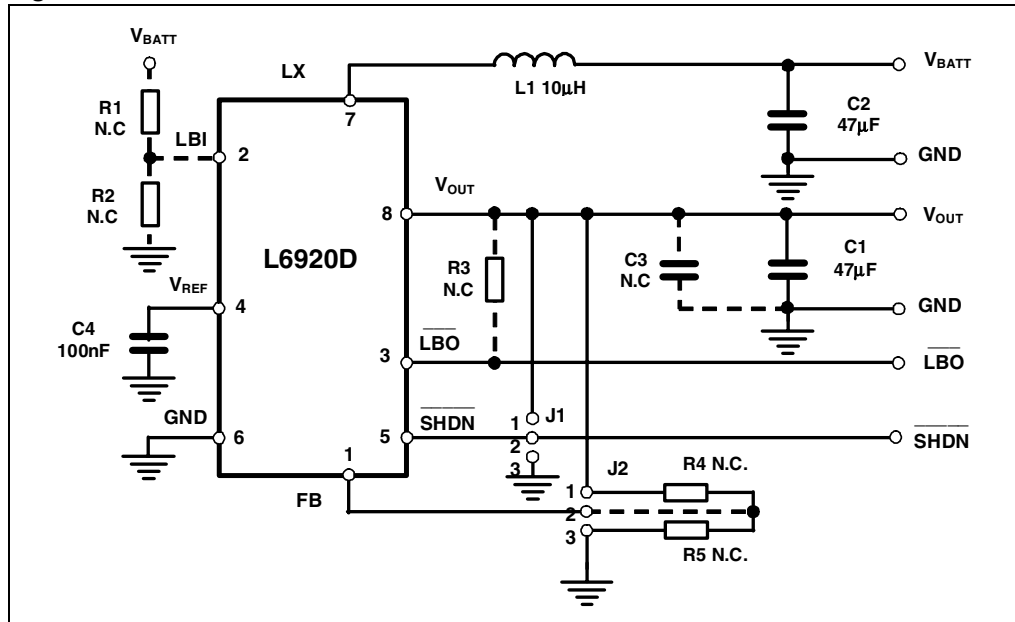

Table 4. Demo board components description

Name	Value	Manufacturer	Description
R1	N.C		Low battery Input resistor divider
R2	N.C		

Table 4. Demo board components description (continued)

Name	Value	Manufacturer	Description
R3	N.C		Pull-up resistor. Connected between VOUT and LBO pins.
R4	N.C		Output voltage resistor divider
R5	N.C		
C1	47 μ F	PANASONIC EEFCDJ470R	Output capacitor
C2	47 μ F	PANASONIC EEFCDJ470R	Input capacitor
C3	1 μ F		High frequency filter capacitor
C4	100 nF		V _{REF} filter capacitor
U1		L6920DB	
L1	10 μ H	PANASONIC ELL6RH100M	Inductor

Table 5. Jumper connections

Jumper	Position	Function
J1	1-2	Device enabled
	2-3	Device disabled
J2	None	Adjustable using R4 and R5 (not mounted)
	1-2	3.3 V output voltage
	2-3	5 V output voltage

1.7 Layout guidelines

The board layout is very important in order to minimize noise, high frequency resonance problems and electromagnetic interference. It is essential to keep the high switching current circulating paths as small as possible to reduce radiation and resonance problems. The output and input cap should be very close to the device.

The external resistor dividers, if used, should be as close as possible to the FB and LBI pins of the device, and as far as possible from the high current circulating paths, to avoid pick-up noise.

Large traces for high current paths and an extended ground plane help reduce noise and increase the efficiency.

For an example of recommended layout see the following evaluation board.

Figure 6. Demoboard layout (top view)

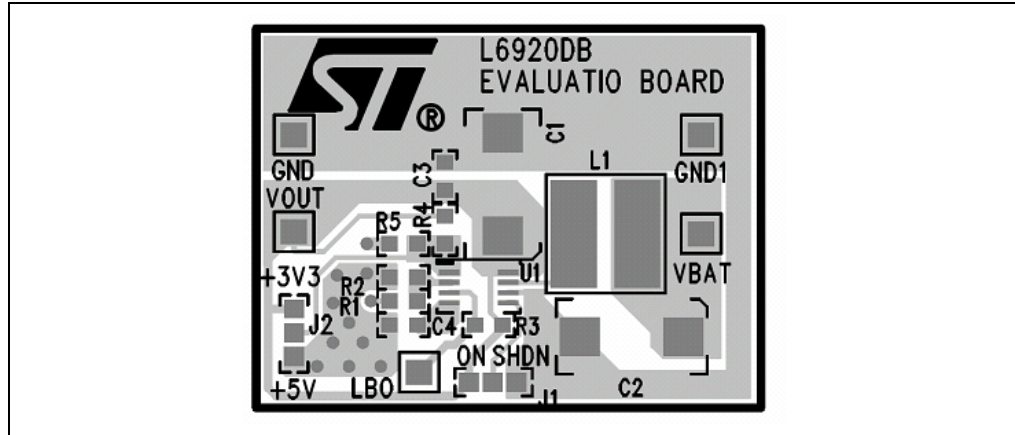
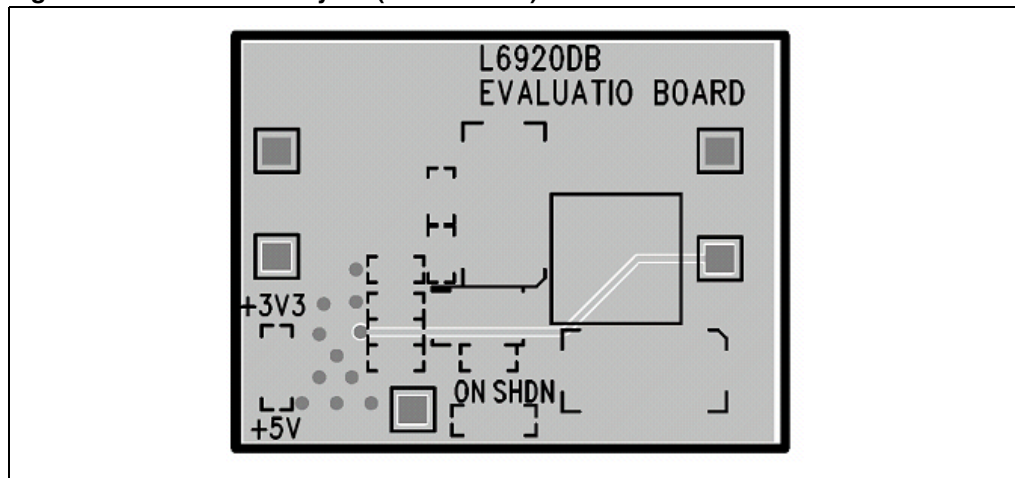

Figure 7. Demoboard layout (bottom view)



2 Typical performance

Figure 8. Efficiency vs. output current at $V_{out} = 3.3\text{ V}$

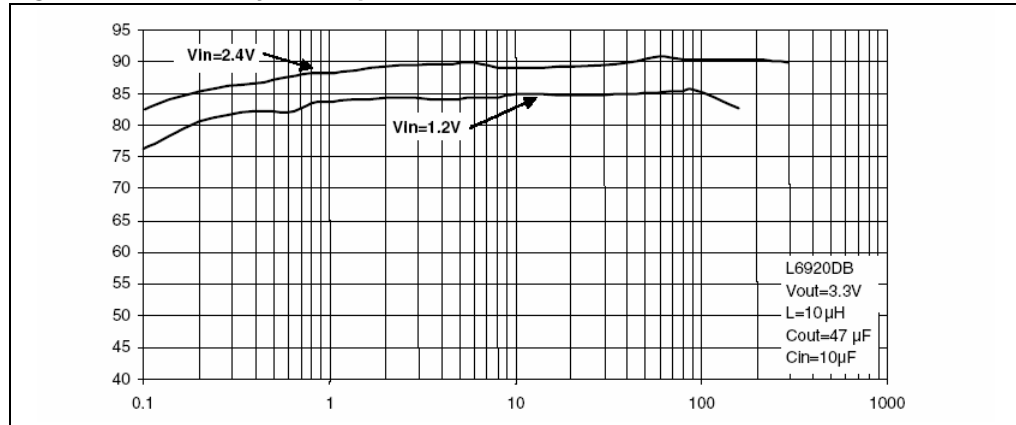

Figure 9. Efficiency vs. output current at $V_{out} = 5\text{ V}$

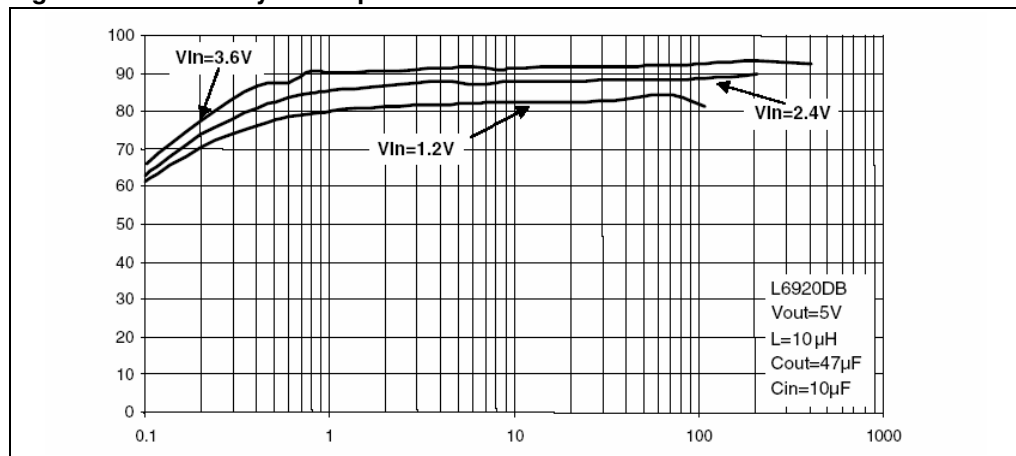

Figure 10. Start-up voltage vs. output current at $V_{out} = 5\text{ V}$

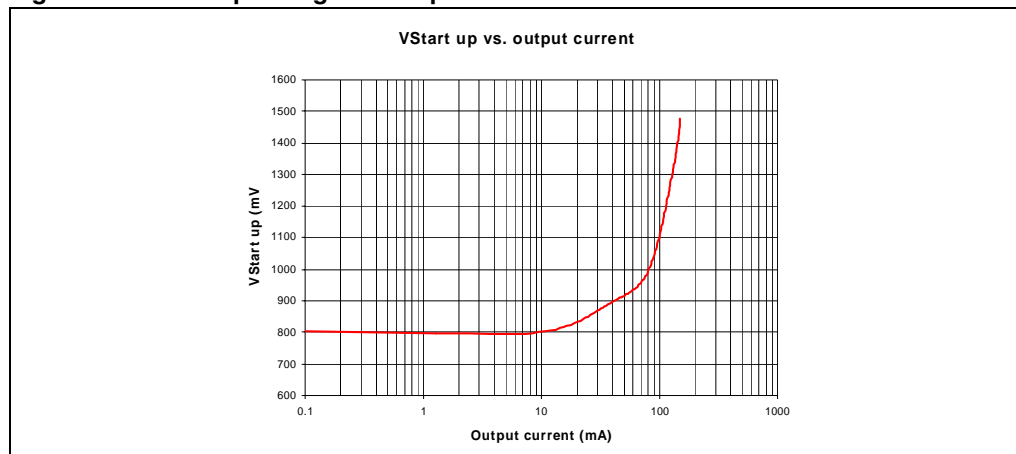
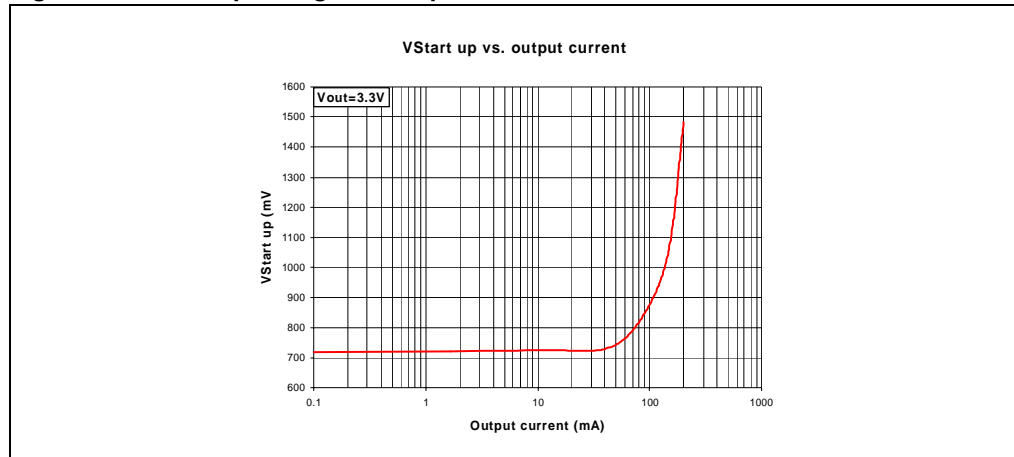

Figure 11. Start-up voltage vs. output current at $V_{out} = 3.3\text{ V}$ 

3 Revision history

Table 6. Revision history

Date	Revision	Changes
05-Dec-2005	1	First issue
09-Feb-2006	2	Text modification
05-Oct-2006	3	- New template - <i>Equation 2</i> modified - <i>Figure 4</i> modified
26-Mar-2007	4	- <i>Table 4</i> modified

Please Read Carefully:

Information in this document is provided solely in connection with ST products. STMicroelectronics NV and its subsidiaries ("ST") reserve the right to make changes, corrections, modifications or improvements, to this document, and the products and services described herein at any time, without notice.

All ST products are sold pursuant to ST's terms and conditions of sale.

Purchasers are solely responsible for the choice, selection and use of the ST products and services described herein, and ST assumes no liability whatsoever relating to the choice, selection or use of the ST products and services described herein.

No license, express or implied, by estoppel or otherwise, to any intellectual property rights is granted under this document. If any part of this document refers to any third party products or services it shall not be deemed a license grant by ST for the use of such third party products or services, or any intellectual property contained therein or considered as a warranty covering the use in any manner whatsoever of such third party products or services or any intellectual property contained therein.

UNLESS OTHERWISE SET FORTH IN ST'S TERMS AND CONDITIONS OF SALE ST DISCLAIMS ANY EXPRESS OR IMPLIED WARRANTY WITH RESPECT TO THE USE AND/OR SALE OF ST PRODUCTS INCLUDING WITHOUT LIMITATION IMPLIED WARRANTIES OF MERCHANTABILITY, FITNESS FOR A PARTICULAR PURPOSE (AND THEIR EQUIVALENTS UNDER THE LAWS OF ANY JURISDICTION), OR INFRINGEMENT OF ANY PATENT, COPYRIGHT OR OTHER INTELLECTUAL PROPERTY RIGHT.

UNLESS EXPRESSLY APPROVED IN WRITING BY AN AUTHORIZED ST REPRESENTATIVE, ST PRODUCTS ARE NOT RECOMMENDED, AUTHORIZED OR WARRANTED FOR USE IN MILITARY, AIR CRAFT, SPACE, LIFE SAVING, OR LIFE SUSTAINING APPLICATIONS, NOR IN PRODUCTS OR SYSTEMS WHERE FAILURE OR MALFUNCTION MAY RESULT IN PERSONAL INJURY, DEATH, OR SEVERE PROPERTY OR ENVIRONMENTAL DAMAGE. ST PRODUCTS WHICH ARE NOT SPECIFIED AS "AUTOMOTIVE GRADE" MAY ONLY BE USED IN AUTOMOTIVE APPLICATIONS AT USER'S OWN RISK.

Resale of ST products with provisions different from the statements and/or technical features set forth in this document shall immediately void any warranty granted by ST for the ST product or service described herein and shall not create or extend in any manner whatsoever, any liability of ST.

ST and the ST logo are trademarks or registered trademarks of ST in various countries.

Information in this document supersedes and replaces all information previously supplied.

The ST logo is a registered trademark of STMicroelectronics. All other names are the property of their respective owners.

© 2007 STMicroelectronics - All rights reserved

STMicroelectronics group of companies

Australia - Belgium - Brazil - Canada - China - Czech Republic - Finland - France - Germany - Hong Kong - India - Israel - Italy - Japan - Malaysia - Malta - Morocco - Singapore - Spain - Sweden - Switzerland - United Kingdom - United States of America

www.st.com

