

Pin Assignments

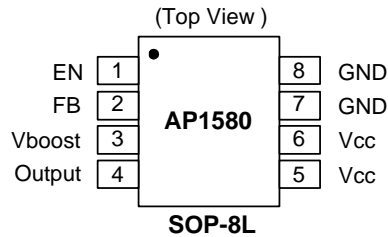

Pin Descriptions

Pin Name	Pin #	Description
EN	1	H: Normal operation L: Step-down operation stopped
FB	2	Feedback pin
V _{boost}	3	High-side gate driver boost pin
Output	4	Switch output pin
V _{cc}	5, 6	Signal V _{cc}
GND	7, 8	GND pin

Block Diagram

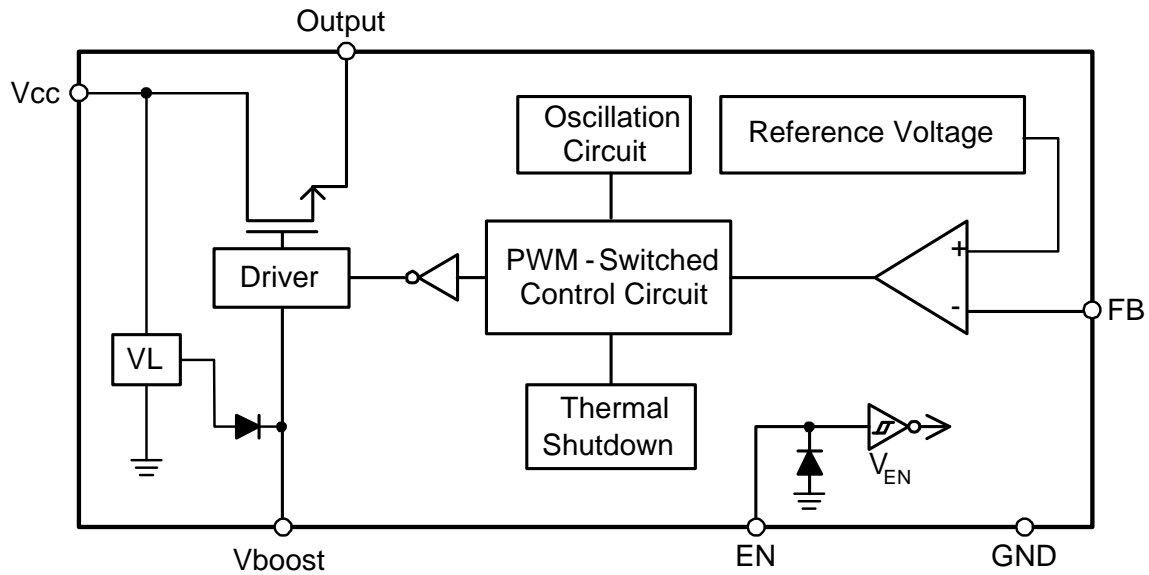

Absolute Maximum Ratings

Symbol	Parameter	Rating	Unit
V _{CC}	V _{CC} Pin Voltage	V _{SS} - 0.3 to V _{SS} + 45	V
V _{FB}	V _{OUT} Pin Voltage	V _{SS} - 0.3 to V _{CC}	V
V _{EN}	EN Pin Voltage	V _{SS} - 0.3 to V _{CC} + 0.3	V
V _{boost}	V _{boost} Pin Voltage	V _{OUTPUT} + 5V	V
V _{OUTPUT}	Switch Pin Voltage	V _{SS} - 0.3 to V _{CC} + 0.3	V
Top	Operating Junction Temperature Range	-25 to +125	°C
T _{ST}	Storage Temperature Range	-40 to +150	°C

Caution: The absolute maximum ratings are rated values exceeding which the product could suffer physical damage. These values must therefore not be exceeded under any conditions.

Recommended Operating Conditions

Symbol	Parameter	Min	Max	Unit
V _{IN}	Input Voltage	10	40	V
I _{OUT}	Output Current	0	3	A
T _A	Operating Ambient Temperature	-25	85	°C

Electrical Characteristics (V_{IN} = 12V, T_A = 25°C, unless otherwise specified)

Symbol	Parameter	Conditions	Min.	Typ.	Max.	Unit
V _{FB}	Feedback Voltage		0.780	0.8	0.820	V
V _{IN}	Input Voltage		10	-	40	V
I _{STBY}	Standby Current	V _{EN} = 0V	-	-	2	µA
ΔV _{OUT} /V _{OUT}	Line Regulation	V _{IN} = 10V~40V	-	±1.0	±1.5	%
ΔV _{OUT} /V _{OUT}	Load Regulation	I _{OUT} = 0.1 to 3A	-	±0.8	±1	%
f _{OSC}	Oscillation Frequency	Measure waveform at SW pin	240	300	360	KHz
f _{OSC1}	Frequency of Current Limit or Short Circuit Protect	Measure waveform at SW pin	-	30	-	KHz
DC	Maximum Duty Cycle	V _{FB} = 0.5V	-	90	-	%
	Minimum Duty Cycle	V _{FB} = 1.0V	-	0	-	%
V _{IH}	EN Pin Logic Input Threshold Voltage	Regulator ON	2.0	-	-	V
V _{IL}		Regulator OFF	--	-	0.8	
I _{SH}	EN Pin Input Leakage Current		-	20	-	µA
I _{SL}			-	-10	-	µA
R _{DS(ON)}	Internal MOSFET R _{DS(ON)}		-	80	120	mΩ
I _{LIMIT}	Current Limit		4	4.5	-	A
η	Efficiency	V _{IN} = 12V, V _{OUT} = 5V, I _{OUT} = 3A	-	90	-	%
θ _{JA}	Thermal Resistance Junction-to-Ambient (Note 4)		-	149	-	°C/W
θ _{JC}	Thermal Resistance Junction-to-Case (Note 4)		-	13.4	-	°C/W

Notes: 3. The PCB layout copper area should be much greater than 10*10mm at the Vcc pins (5&6) of the AP1580, if you need large PD or low Tc&T_A. The dual Vcc pins (5&6) on the SOP-8L package are internally connected.
4. Devices mounted on 2oz copper, minimum recommended pad layout, FR-4 PCB.

Typical Application Circuit

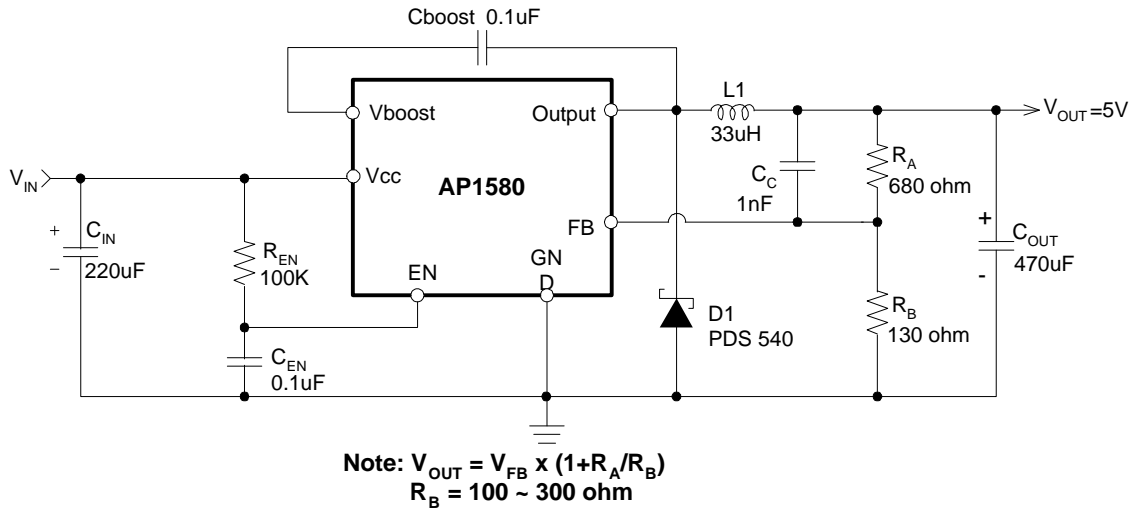

Typical Performance Characteristics

Line Regulation

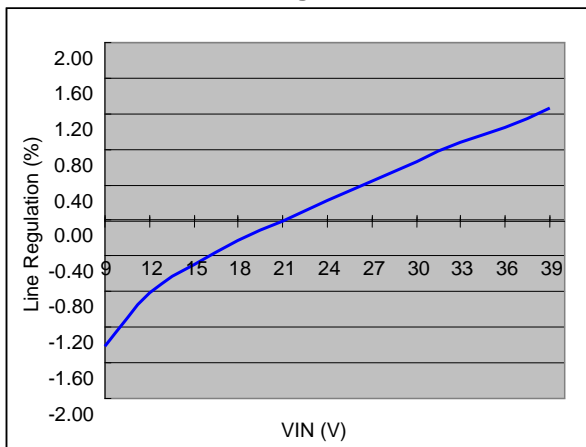

Load Regulation

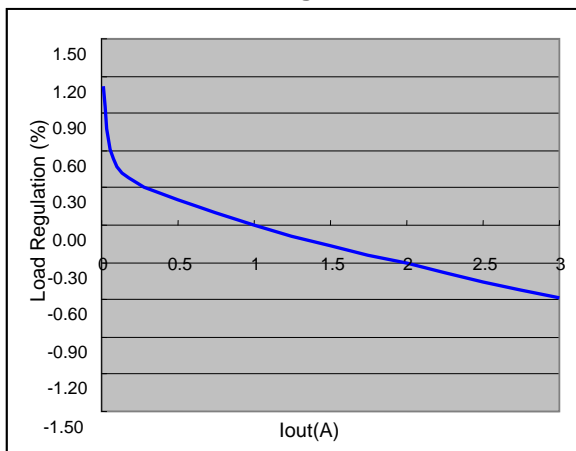

Frequency vs. Vin

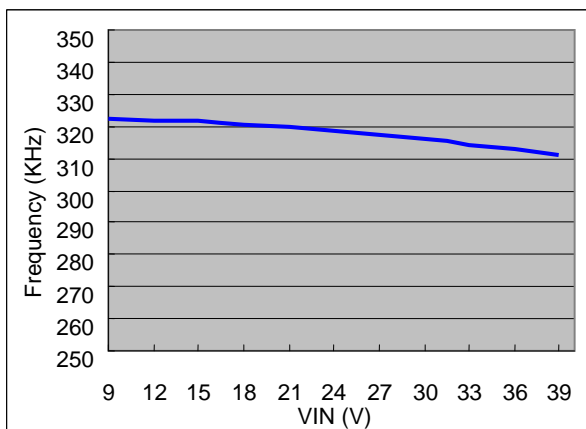

Iccq vs. Vin

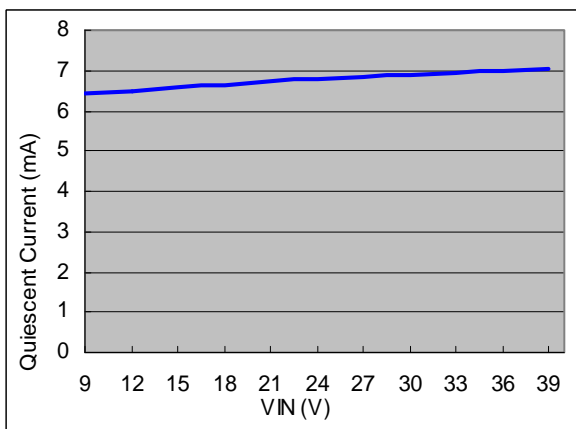

Efficiency

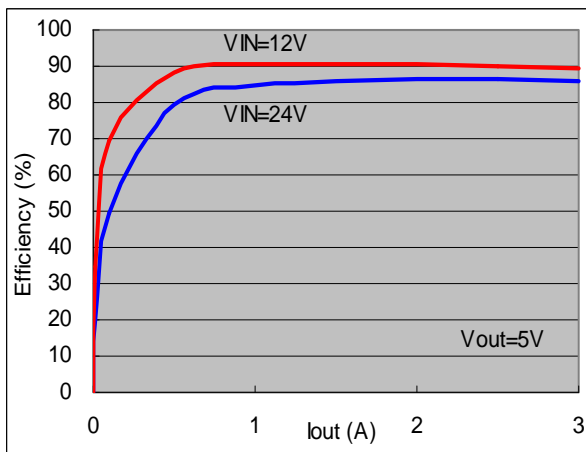

Typical Performance Characteristics (Continued)

Vout Ripple
(Vcc=24V; Vout=3.3V, Iout=0.5A, Vripple=19.0mV)

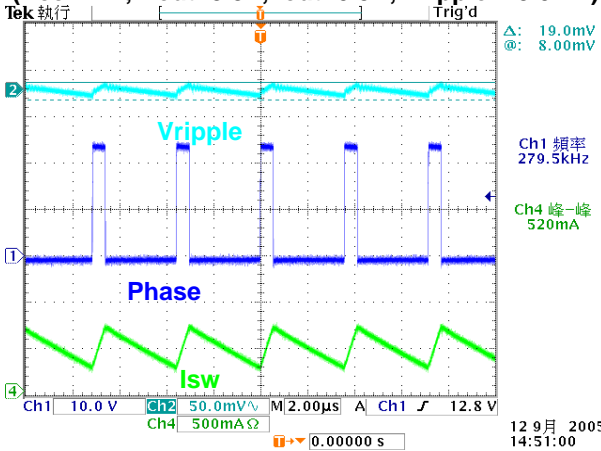

Vout Ripple
(Vcc=24V; Vout=3.3V, Iout= 3A, Vripple=35.0mV)

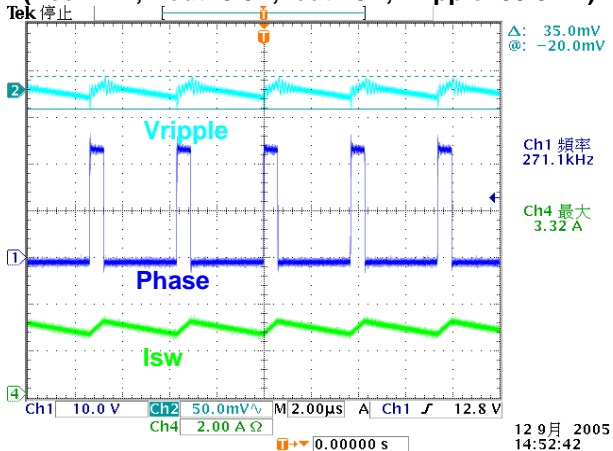

Power Transient Wave
(Iout=0~3 A, Vin=24V, Vout =3.3V)

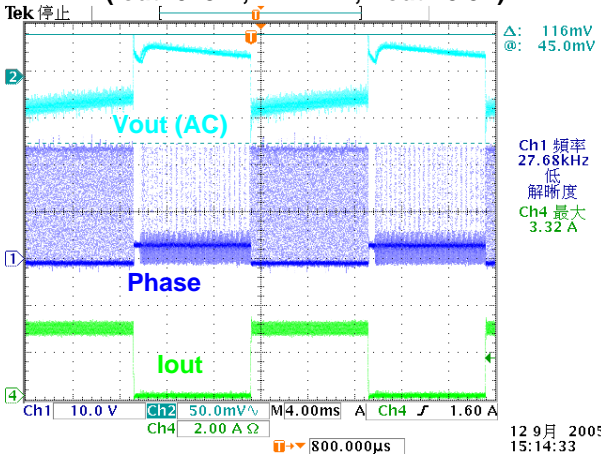

Power Transient Wave
(Iout=0.1~3 A, Vin =12V, Vout =3.3V)

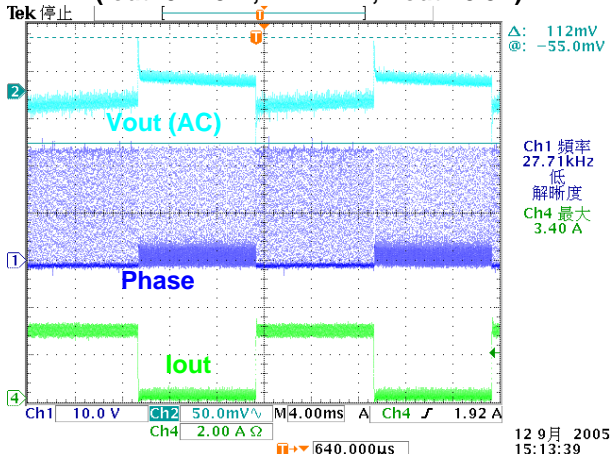

Test Circuit

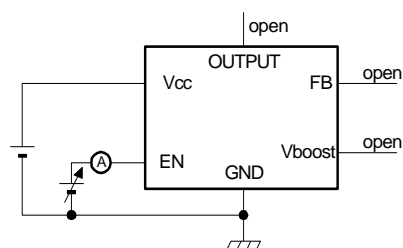

Enable function test

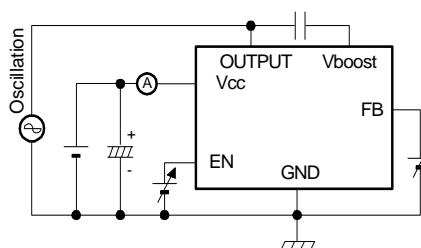

Feedback function test

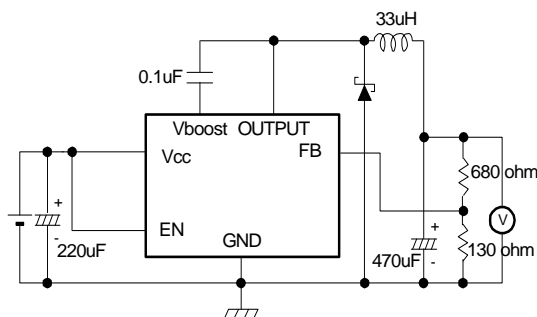

Operation function test

Function Description

PWM Control

The AP1580 consists of DC/DC converters that employ a pulse-width modulation (PWM) system. The PWM controller is internally clocked by a fixed 300KHz oscillator. In converters of the AP1580, the pulse width varies in a range from 0 to 90%, according to the load current. The ripple voltage produced by the switching can easily be removed through a filter because the switching frequency remains constant. Therefore, these converters provide a low-ripple power over broad ranges of input voltage and load current.

Enable Control

This input provides an electrical ON/OFF control of the power supply. Connecting this pin to ground or to any voltage less than 0.8V will completely turn OFF the regulator. The current drain from the input supply when OFF is only 2uA.

C BOOST

A capacitor must be connected from pin 3 to the switch output, pin 4. This capacitor boosts the gate drive to the internal MOSFET above Vin to fully turn it ON. This minimizes conduction losses in the power switch to maintain high efficiency. The recommended value for C Boost is 0.1uF.

FEEDBACK

This is the input to a two-stage high gain amplifier, which drives the PWM controller. It is necessary to connect pin 2 to the actual output of the power supply to set the DC output voltage. Two external resistors are required to set the DC output voltage. For stable operation of the power supply, it is important to prevent coupling of any inductor flux to the feedback input.

Current Limit

The current limit threshold is set by the internal circuit that minimum switching current is 4A. The output voltage will be reduced immediately and switching frequency will be dropped to 30KHz when switching current over limit threshold.

Thermal shutdown

The thermal shutdown temperature depends on internal junction temperature. When junction temperature rises up to 140°C, the device will be shut down and it will be recovered after temperature reduced lower than 90°C.

Marking Information

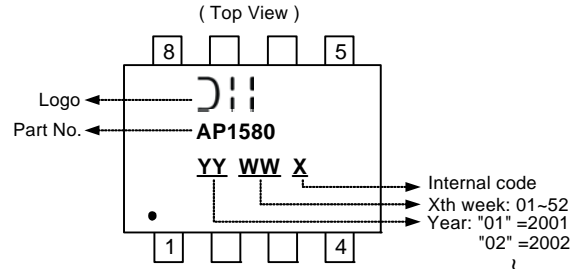

Package Information (unit: mm)

Package Type: SOP-8L

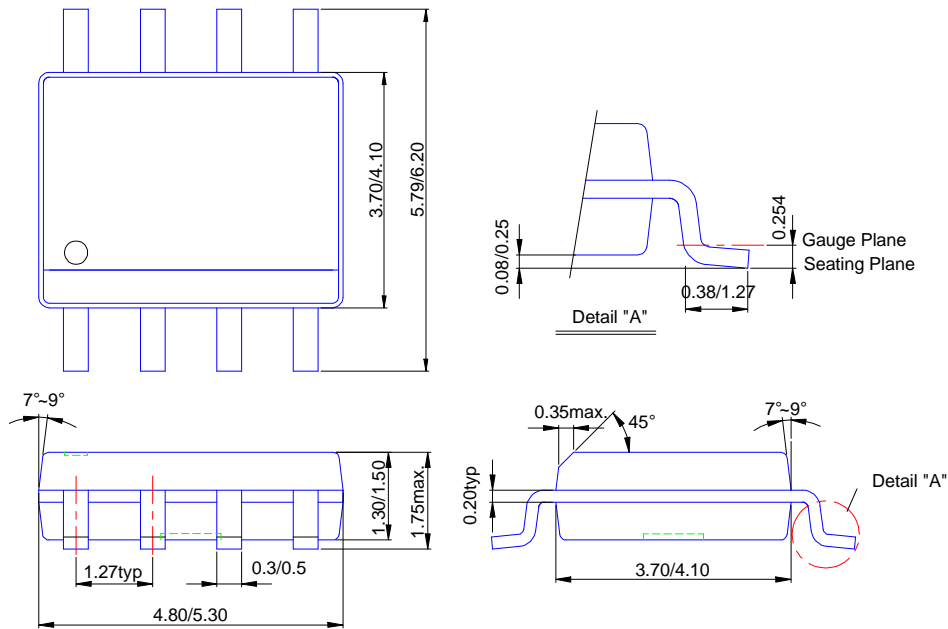

IMPORTANT NOTICE

Diodes Incorporated and its subsidiaries reserve the right to make modifications, enhancements, improvements, corrections or other changes without further notice to any product herein. Diodes Incorporated does not assume any liability arising out of the application or use of any product described herein; neither does it convey any license under its patent rights, nor the rights of others. The user of products in such applications shall assume all risks of such use and will agree to hold Diodes Incorporated and all the companies whose products are represented on our website, harmless against all damages.

LIFE SUPPORT

Diodes Incorporated products are not authorized for use as critical components in life support devices or systems without the expressed written approval of the President of Diodes Incorporated.