

FEATURES

- **Small Solution Size**
- **>85% Efficiency over Wide Load Range**
- **Internal Synchronous Rectifier**
- V_{IN} Range: 1.5V to 5.5V
- 5V at 30mA from 3.3V Input
- 3.3V at 20mA from 2 AA Cell Input
- Programmable Output Voltages Up to 10V
- Burst Mode[®] Operation
- Inrush Current Limiting
- Output Disconnect in Shutdown
- Ultralow Quiescent (10 μ A) and Shutdown (<1 μ A) Currents
- Low Profile 2mm \times 2mm DFN, 2mm \times 3mm DFN or SOT-23 Package

APPLICATIONS

- General Purpose Micropower Boost
- Digital Cameras
- PDAs
- LCD Bias
- Small OLED Displays
- Supercap Charging

DESCRIPTION

The LTC[®]3459 is a low current, high efficiency synchronous boost converter intended for low power, size constrained portable applications. The LTC3459 can be powered from a single lithium ion battery, a 2- to 3-cell stack of alkaline or nickel batteries, or any low impedance voltage source between 1.5V and 5.5V. The output is programmable via an external divider between 2.5V and 10V. Although the part is primarily intended for boost applications, V_{OUT} will maintain regulation below V_{IN} (at reduced efficiency).

The LTC3459 offers Burst Mode operation with a fixed peak current, providing high conversion efficiency over a wide range of load currents. During start-up, inductor current is controlled preventing the inrush surge current found in many boost converters. In shutdown the output is disconnected from the input and quiescent current is reduced to <1 μ A.

The LTC3459 is offered in low profile 6-pin 2mm \times 2mm DFN, 2mm \times 3mm DFN or SOT-23 (ThinSOT[™]) packages, allowing a tiny footprint for the total solution.

LT, LT, LTC, LTM and Burst Mode are registered trademarks of Linear Technology Corporation. ThinSOT is a trademark of Linear Technology Corporation. All other trademarks are the property of their respective owners.

TYPICAL APPLICATION

5V to 8V Converter

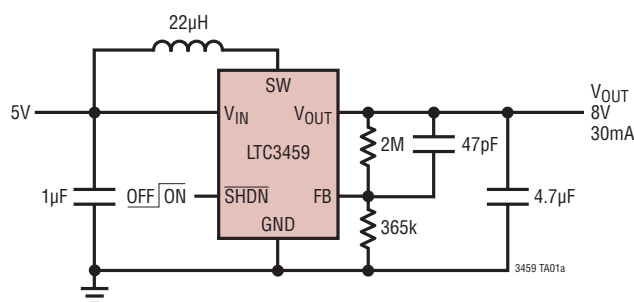

Efficiency

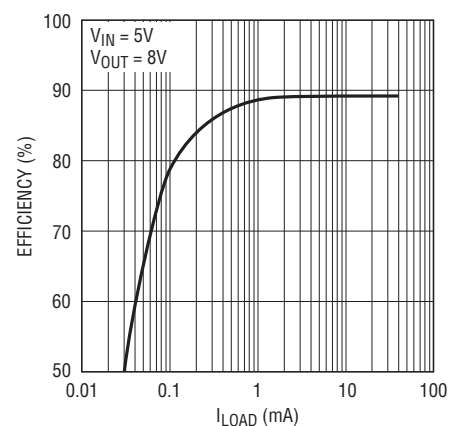

3459 TA01b

3459fc

ABSOLUTE MAXIMUM RATINGS

Referred to GND (Note 1)

V_{IN} , FB Voltage	-0.3V to 7V	Storage Temperature Range.....	-65°C to 150°C
V_{OUT} , SHDN Voltage	-0.3V to 10V	Reflow Temperature.....	260°C
SW Voltage	-0.3V to 12V	Lead Temperature, S6 Package	
Operating Temperature Range		(Soldering, 10 sec)	300°C
(Notes 2, 3)	-40°C to 85°C		

PIN CONFIGURATION

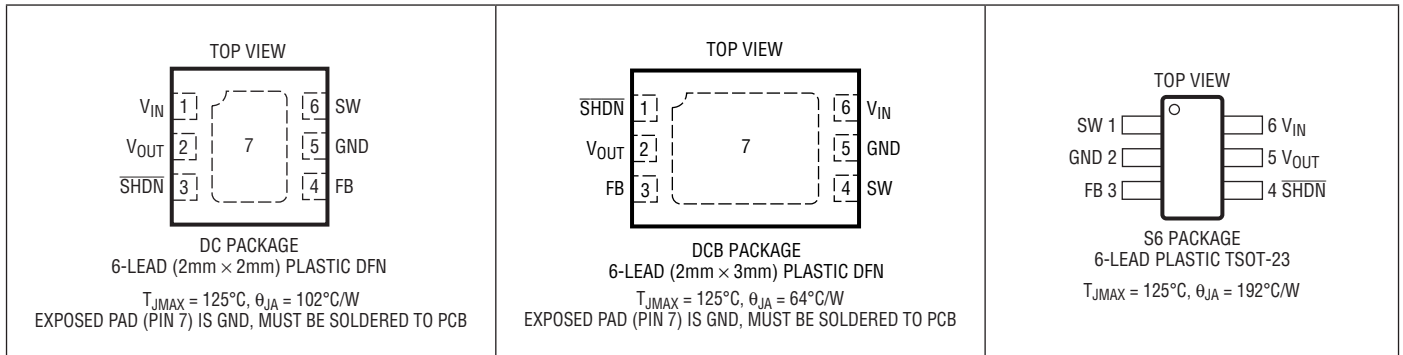

ORDER INFORMATION

LEAD FREE FINISH	TAPE AND REEL	PART MARKING	PACKAGE DESCRIPTION	TEMPERATURE RANGE
LTC3459EDC#PBF	LTC3459EDC#TRPBF	LDTG	Low Profile (2mm × 2mm) Plastic DFN	-40°C to 85°C
LTC3459EDCB#PBF	LTC3459EDCB#TRPBF	LDMM	Low Profile (2mm × 3mm) Plastic DFN	-40°C to 85°C
LTC3459ES6#PBF	LTC3459ES6#TRPBF	LTAHA	Low Profile SOT-23	-40°C to 85°C

Consult LTC Marketing for parts specified with wider operating temperature ranges.

Consult LTC Marketing for information on non-standard lead based finish parts.

For more information on lead free part marking, go to: <http://www.linear.com/leadfree/>

For more information on tape and reel specifications, go to: <http://www.linear.com/tapeandreeel/>

ELECTRICAL CHARACTERISTICS

The ● denotes the specifications which apply over the full operating temperature range, otherwise specifications are at $T_A = 25^\circ\text{C}$. $V_{\text{IN}} = 3.3\text{V}$, $V_{\text{OUT}} = 5\text{V}$, unless otherwise noted.

PARAMETER	CONDITIONS	MIN	TYP	MAX	UNITS	
V_{IN}						
Input Voltage Range		● 1.5		5.5	V	
V_{IN} Quiescent Current	$\overline{\text{SHDN}} = V_{\text{CC}}$		10	20	μA	
V_{IN} Shutdown Current	$\overline{\text{SHDN}} = \text{GND}$		0.1	1	μA	
V_{OUT}						
Programmable Voltage Range		● 2.5		10	V	
V_{OUT} Quiescent Supply Current	$\overline{\text{SHDN}} = V_{\text{CC}}$		2	4	μA	
V_{OUT} Shutdown Current	$\overline{\text{SHDN}} = \text{GND}$		0.1	1	μA	
Reference						
Feedback Voltage	$V_{\text{IN}} = 3.3\text{V}$, $V_{\text{OUT}} = 7.5\text{V}$	● 1.19	1.22	1.25	V	
FB Input Leakage Current	Measured on FB		10	50	nA	
Converter Performance						
Peak Switch Current ($V_{\text{IN}} = 3.3\text{V}$)	$L = 22\mu\text{H}$	● 60	75	90	mA	
t_{OFF} Timer ($V_{\text{IN}} = 3.3\text{V}$, $V_{\text{OUT}} = 5\text{V}$)	Varies by $1/(V_{\text{OUT}} - V_{\text{IN}})$		225	400	550	ns
Zero Current Comparator Threshold	$L = 22\mu\text{H}$		0		mA	
Main NMOS Switch						
On-Resistance	$V_{\text{OUT}} = 5\text{V}$		2.8		Ω	
Leakage Current	$V_{\text{SWITCH}} = 10\text{V}$, $V_{\text{OUT}} = 10\text{V}$		0.01	1	μA	
Main PMOS Switch						
On-Resistance	$V_{\text{OUT}} = 5\text{V}$		4.2		Ω	
Leakage Current	$V_{\text{IN}} = 5\text{V}$, $V_{\text{SWITCH}} = 5\text{V}$, $V_{\text{OUT}} = 0\text{V}$		0.02	2	μA	
Logic Inputs						
$\overline{\text{SHDN}}$ Threshold (Rising Edge)		0.3		1	V	
$\overline{\text{SHDN}}$ Hysteresis			80		mV	
$\overline{\text{SHDN}}$ Input Leakage Current	$\overline{\text{SHDN}} = 3.3\text{V}$		0	50	nA	

Note 1: Stresses beyond those listed under Absolute Maximum Ratings may cause permanent damage to the device. Exposure to any Absolute Maximum Rating condition for extended periods may affect device reliability and lifetime.

Note 2: The LTC3459E is guaranteed to meet performance specifications from 0°C to 85°C . Specifications over the -40°C to 85°C operating temperature range are assured by design, characterization and correlation with statistical process controls.

Note 3: This IC includes overtemperature protection that is intended to protect the device during momentary overload conditions. Junction temperature will exceed 125°C when overtemperature protection is active. Continuous operation above the specified maximum operating junction temperature may impair device reliability.

TYPICAL PERFORMANCE CHARACTERISTICS ($T_A = 25^\circ\text{C}$, unless otherwise noted).

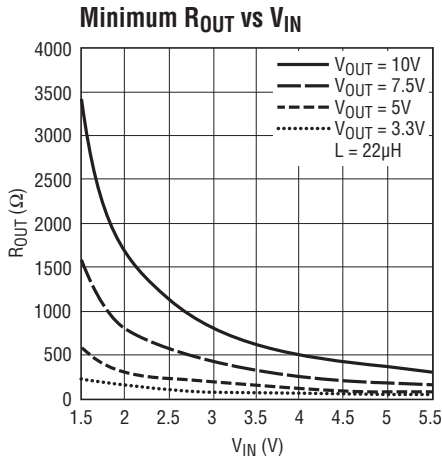

3459 G01

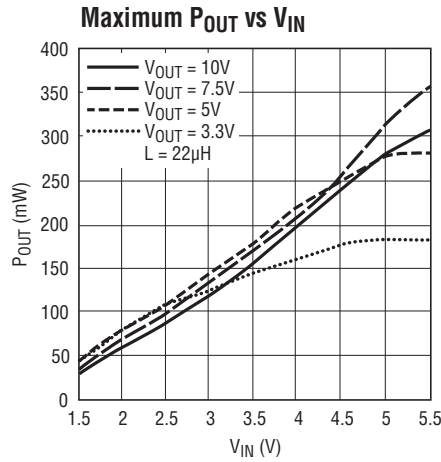

3459 G02

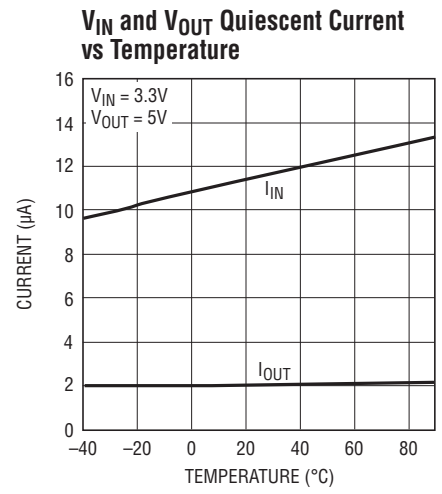

3459 G03

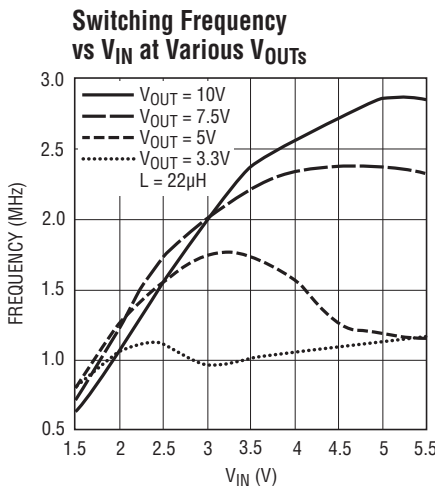

3459 G04

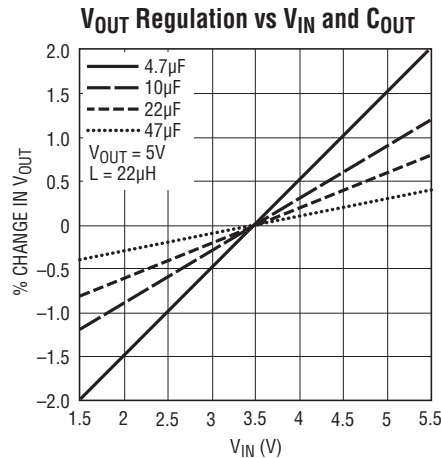

3459 G05

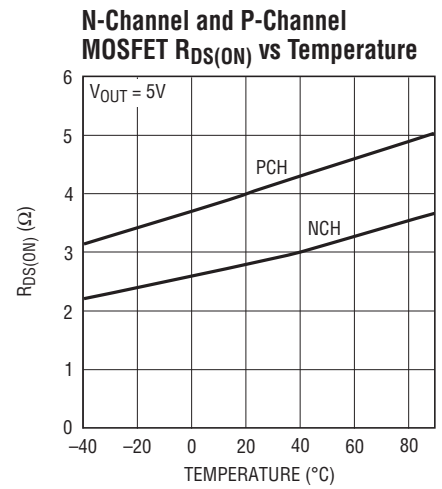

3459 G06

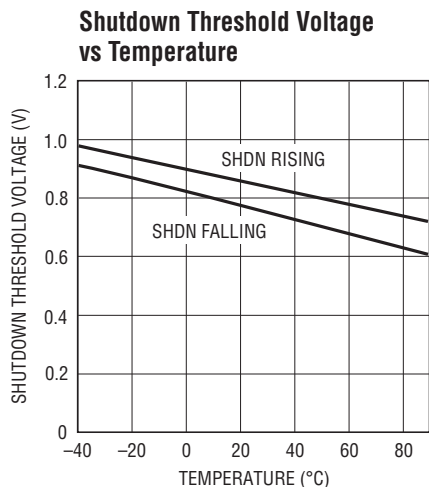

3459 G07

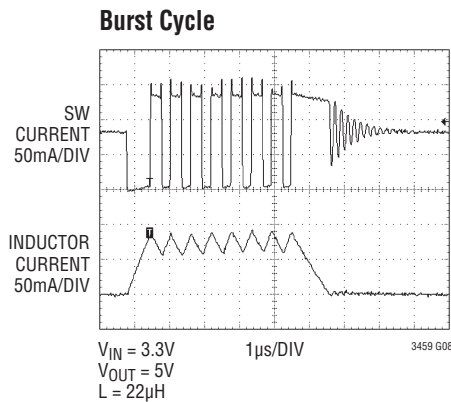

3459 G08

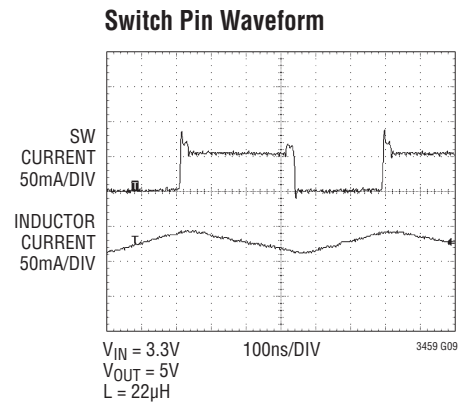

3459 G09

TYPICAL PERFORMANCE CHARACTERISTICS ($T_A = 25^\circ\text{C}$, unless otherwise noted).

V_{OUT} AC Ripple

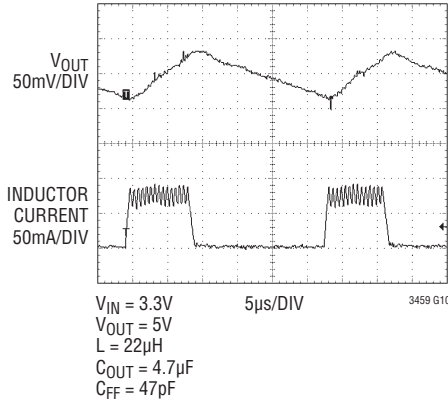

Burst Cycle

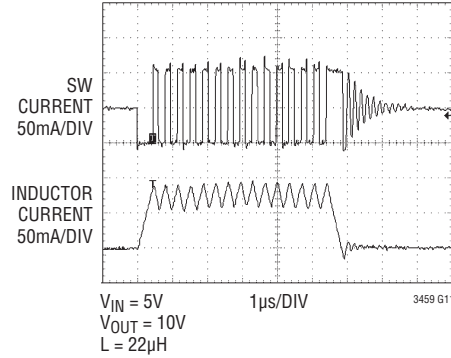

Burst Cycle

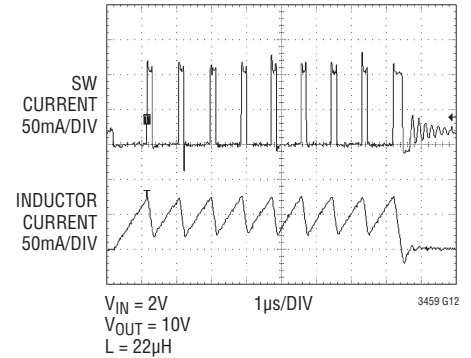

V_{OUT} Regulated Below V_{IN} Burst Cycle

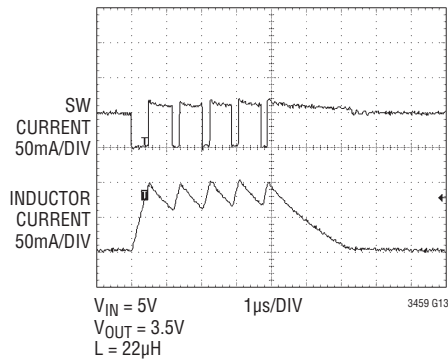

Shorted Output

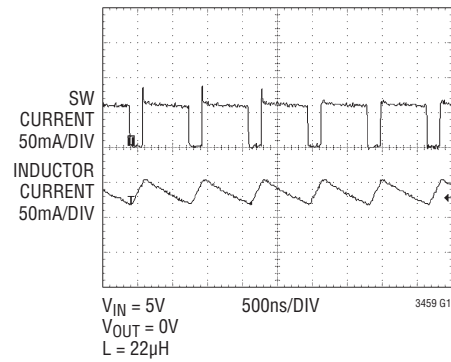

Start-Up

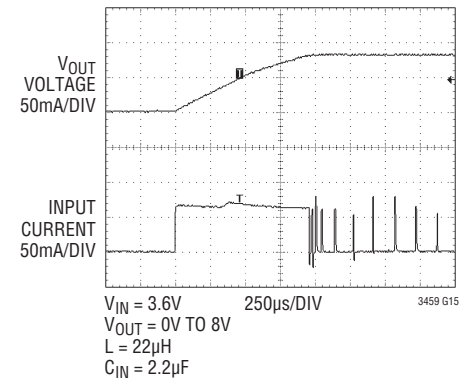

Load Steps

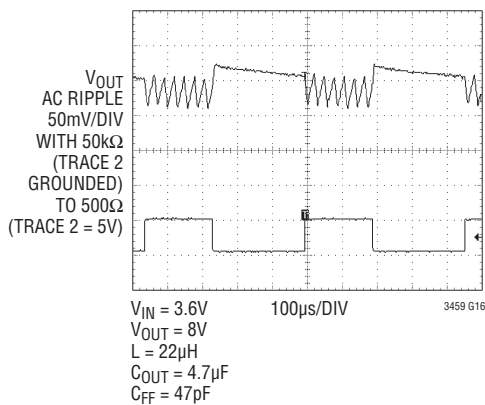

Load Steps

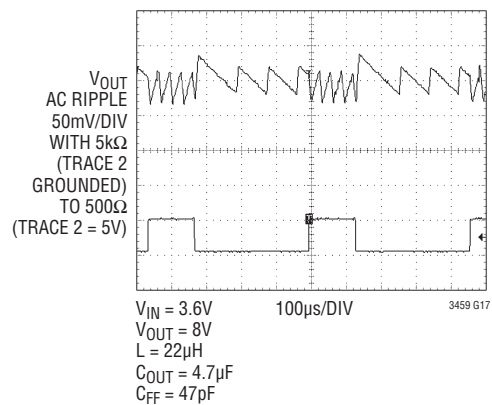

PIN FUNCTIONS (DC/DCB/S6 Packages)

V_{IN} (Pin 1/Pin 6/Pin 6): Input Supply Pin. Bypass V_{IN} with a low ESR, ESL ceramic capacitor of at least 1μF.

V_{OUT} (Pin 2/Pin 2/Pin 5): Regulated Output Voltage of the Boost Regulator. Bypass V_{OUT} with a low ESR, ESL ceramic capacitor between 2.2μF and 10μF. V_{OUT} ripple increases with smaller capacitors.

SHDN (Pin 3/Pin 1/Pin 4): Master Shutdown Input. Driving SHDN low disables all IC functions and reduces quiescent current from the battery to less than 1μA. This pin must be pulled above 1V to enable the IC.

FB (Pin 4/Pin 3/Pin 3): Input to the Burst Mode Comparator. An external resistor divider connected between V_{OUT}, GND and this pin sets the output voltage to:

$$V_{OUT} = 1.22(1 + R1/R2)$$

GND (Pin 5/Pin 5/Pin 2): Signal and Power Ground. Provide a short, direct PCB path between GND and the (-) side of the filter capacitors on V_{IN} and V_{OUT}.

SW (Pin 6/Pin 4/Pin 1): Switch Pin. Connect a 15μH to 33μH inductor between SW and V_{IN}. Keep PCB trace lengths as short and wide as possible to reduce EMI and voltage overshoot. If the inductor current falls to zero, the internal P-channel MOSFET synchronous rectifier is turned off to prevent reverse charging of the inductor.

Exposed Pad (Pin 7/Pin 7, DC and DCB Packages Only): Ground. The Exposed Pad must be soldered to PCB.

BLOCK DIAGRAM

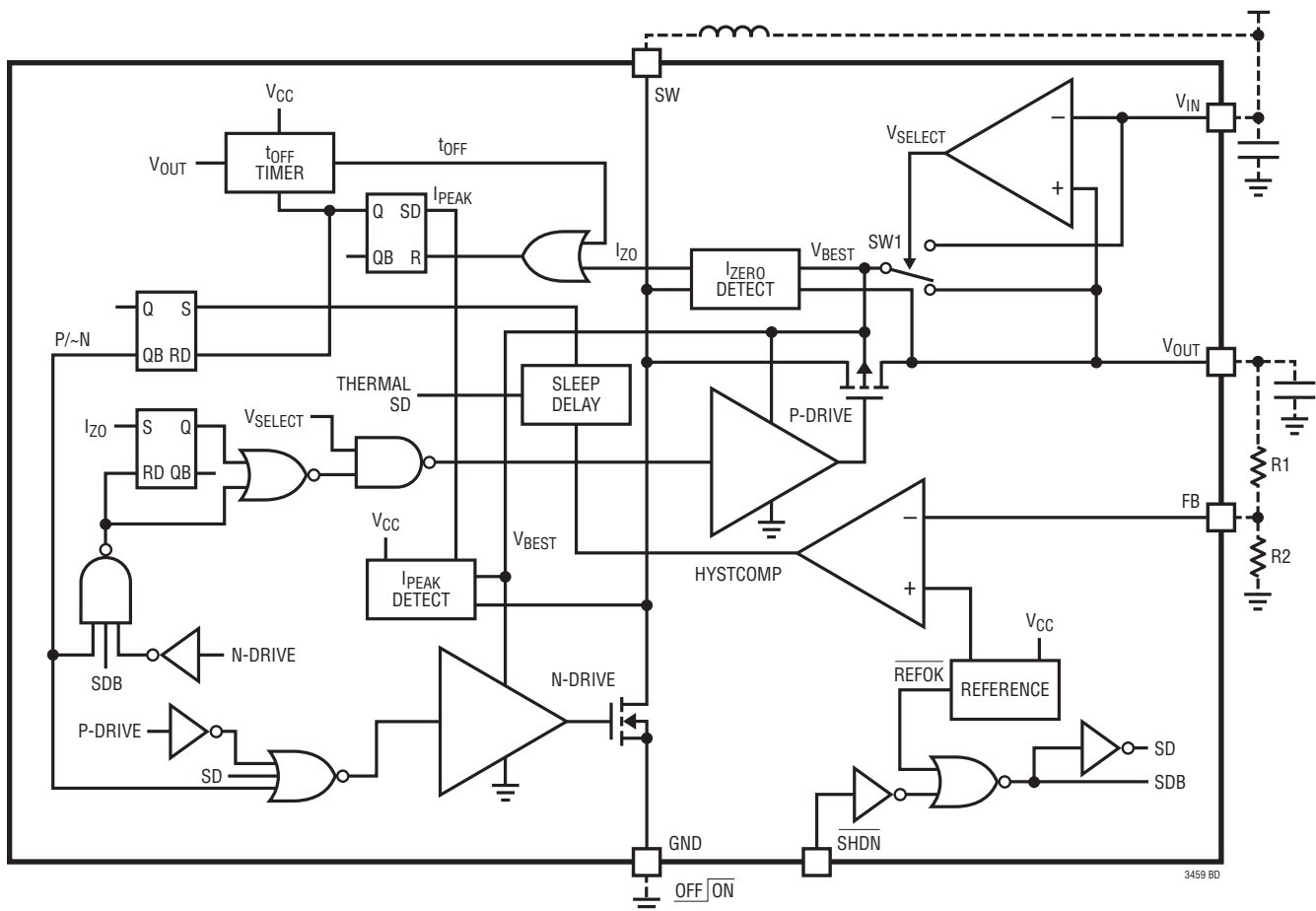

OPERATION

Operation

The LTC3459 synchronous boost converter utilizes a Burst Mode control technique to achieve high efficiency over a wide dynamic range. A 2.5% accurate comparator is used to monitor the output voltage (V_{OUT}), if V_{OUT} is above the comparator threshold, no switching occurs and only quiescent current ($10\mu A$) is drawn from the power source. When V_{OUT} drops below the comparator threshold, switching commences and the output capacitor is charged. During the on time of the switching period, inductor current is ramped through an internal N-channel MOSFET to GND until a peak current ($75mA$) is detected. A P-channel MOSFET connects the inductor to V_{OUT} during the off time delivering energy to the load. The off time is controlled by an internal timer which is proportional to $1/(V_{OUT} - V_{IN})$. Anticross conduction circuitry ensures the N- and P-channel switches are never on simultaneously.

Only three power components and two feedback resistors are required to complete the design of the boost converter, an external Schottky diode is not required. The high operating frequency allows the use of low value, low profile inductors and tiny external ceramic capacitors. The boost

converter disconnects V_{OUT} from V_{IN} during shutdown to avoid loading the input power source.

Peak Current Overshoot

The LTC3459's peak current comparator has a delay of approximately 100ns from the time inductor current reaches current limit until the internal N-channel MOSFET turns off. This delay causes the peak current to overshoot based on the inductor value and V_{IN} , as follows (Figure 2 is based on a 65mA initial I_{LIMIT}).

$$I_{PEAK} = I_{LIMIT} + (100ns) \frac{V_{IN}}{L}$$

t_{OFF} Timer

The LTC3459's t_{OFF} timer is designed to keep the inductor current continuous during a Burst Mode switching packet, thereby increasing current capability at the output. A larger inductor value will have lower peak-to-peak current ripple, increasing the available current to the load. This improvement is offset somewhat by the reduced I_{PEAK} overshoot. The t_{OFF} timer is designed to maintain a relatively constant peak-to-peak current in the inductor despite V_{IN} changes.

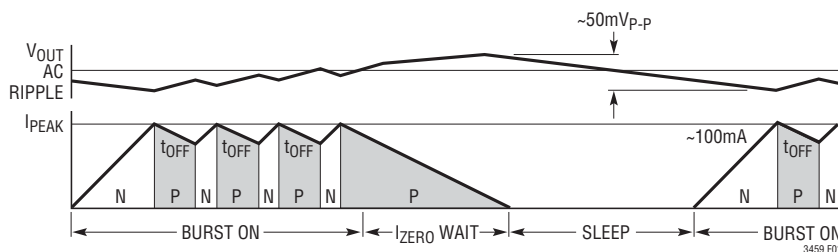

Figure 1. Inductor Current and V_{OUT} Ripple Waveforms

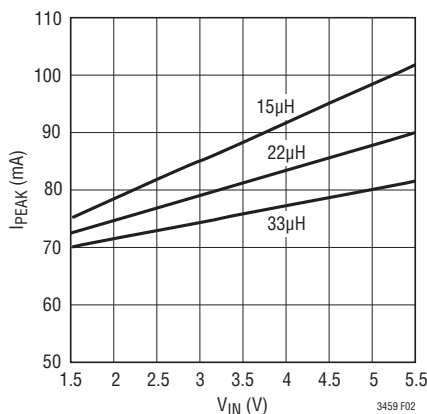

Figure 2. Typical I_{PEAK} Values

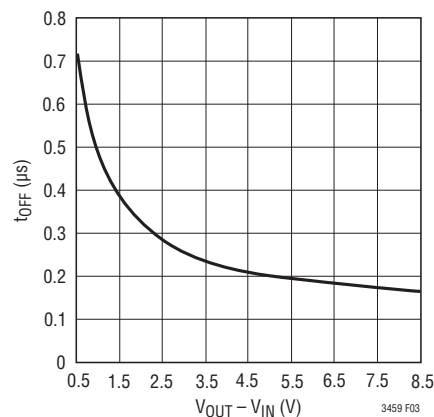

Figure 3. t_{OFF} Times

OPERATION

This is accomplished by varying the t_{OFF} period by approximately $1/(V_{OUT} - V_{IN})$. Due to propagation delays and a $0.6\mu A$ bias current in the timer, the t_{OFF} time can be more accurately predicted as follows:

$$t_{OFF} \approx 100ns + \frac{0.8pF \cdot 1.25V}{0.6\mu A + \frac{V_{OUT} - V_{IN}}{500k}}$$

If V_{OUT} is less than V_{IN} , the t_{OFF} delay is fixed at approximately 750ns.

APPLICATIONS INFORMATION

Inductor Selection

An inductor with a minimum value of $15\mu H$ is recommended for use with the LTC3459. Values larger than $15\mu H$ will result in lower ripple current and switching frequency. High frequency ferrite core materials are strongly recommended. Some inductors meeting these requirements are listed in Table 1.

Table 1. Example Inductors

VENDOR/PART	L (μH)	DCR (Ω)/ I _{MAX} (mA)	DIMENSIONS (mm)	CONTACT INFORMATION
Chip Inductors				
Murata LQH31C	22	3/160	3.2 × 1.6 × 1.8	www.murata.com
LQH32C-Low Profile	22	0.7/250	3.2 × 2.5 × 1.6	
Taiyo Yuden LB2016	15 22 33	0.7/130 1/105 1.7/85	2.0 × 1.6 × 1.6	www.t-yuden.com (408) 573-4150
Toko LLB2520	15 22 33	1.7/180 2.5/160 3.8/130	2.5 × 2.0 × 1.6	www.tokoam.com (847) 297-0070
Coilcraft DO3314	15 22	0.86/650 1.2/500	3.3 × 3.3 × 1.4	www.coilcraft.com (847) 639-6400
DO1606T	15 22 33	0.4/700 0.5/500 0.74/450	6.5 × 5.3 × 2.0	
Sumida CMD4D06	15 22	0.5/400 0.8/300	6.6 × 5.8 × 0.8	www.sumida.com (847) 956-0666
CDRJ2D1BLD	33	1.3/240	3.2 × 3.2 × 2.0	
	15 22 33	0.175/350 0.255/300 0.37/240		

Capacitor Selection

The boost converter requires two capacitors. The input capacitor should be an X5R type of at least $1.0\mu F$. The V_{OUT} capacitor should also be an X5R type between $2.2\mu F$ and $10\mu F$. A larger capacitor should be used if lower peak-to-peak output ripple and better line regulation is desired.

Table 2. Capacitor Vendor Information

SUPPLIER	PHONE	WEBSITE
AVX	(803) 448-9411	www.avxcorp.com
Murata	(714) 852-2001	www.murata.com
Taiyo Yuden	(408) 573-4150	www.t-yuden.com
TDK	(847) 803-6100	www.component.tdk.com

PCB Layout Guidelines

The high speed operation of the LTC3459 demands careful attention to board layout. You will not get advertised performance with a careless layout. Figure 4 shows the recommended component placement for the TSOT version of the part. A large ground pin copper area will help to lower the chip temperature.

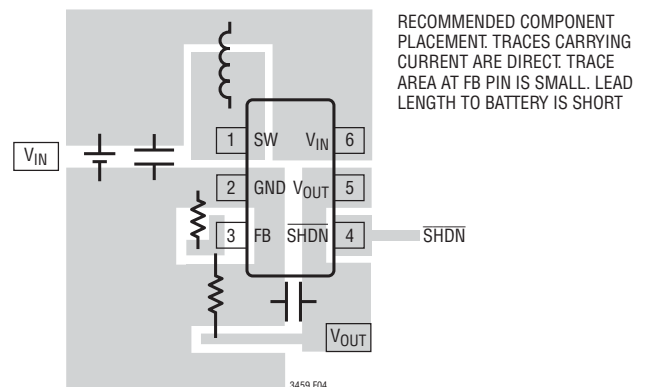

Figure 4. Recommended Component Placement for a Single-Layer Board

TYPICAL APPLICATIONS

Very low operating quiescent current and synchronous operation allow for greater than 85% conversion efficiency in many applications. Lower output voltages will result in lower efficiencies since the N- and P-channel $R_{DS(ON)}$ s will increase. The switching frequency and output power capability of the LTC3459 are also dependant on input and output voltages.

Charging a SuperCap®

SuperCaps have become a popular alternative to NiCd batteries as back-up power sources in portable equipment. Capacitance values of one farad and higher are achievable in small package sizes with leakage currents in the low microamps. SuperCaps are typically charged at low currents for several minutes until they reach the required back-up voltage.

The LTC3459 is designed to control peak inductor current when V_{IN} is greater than or less than V_{OUT} . This allows current to be controlled during start-up in a boost application, for example, or V_{OUT} to be regulated below V_{IN} when powered from a fresh battery. Peak current control makes the LTC3459 an ideal candidate for charging a back-up source such as a SuperCap. Figure 5 shows an application where the LTC3459 is used to charge a two-farad, 5V SuperCap from a 3.3V input. A NiCd battery could be charged by the LTC3459 as well, but that application may require additional circuitry for proper charge termination.

When V_{OUT} is less than ~3.5V, the body of the internal synchronous P-channel MOSFET rectifier is connected to V_{IN} , and the SW pin rises a diode above V_{IN} when current is delivered to the load. While efficiency is compromised in this mode of operation, current to the SuperCap is

5V from Li-Ion Input

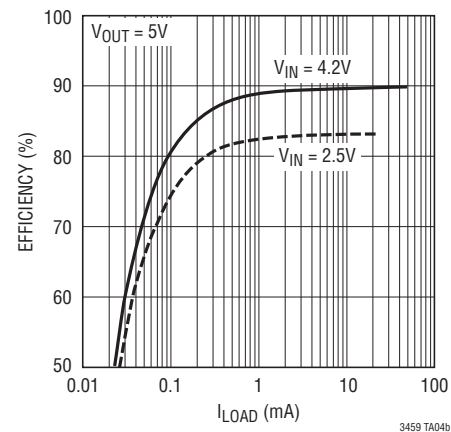
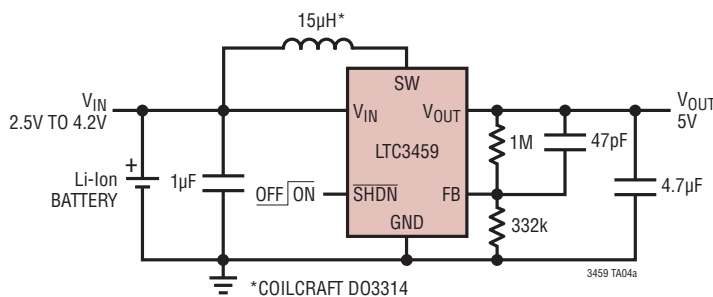

10V from 3.3V or 5V Input

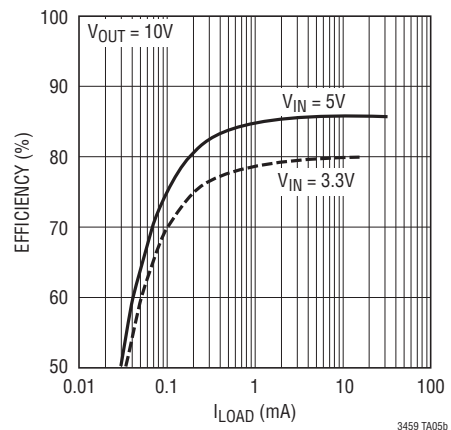
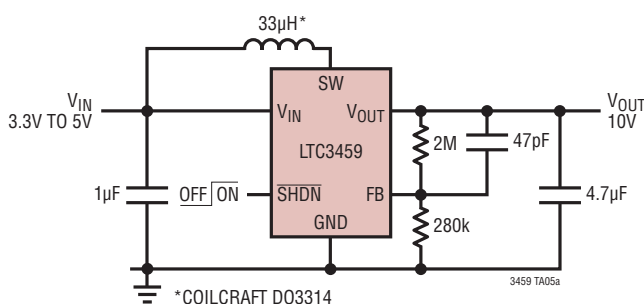

TYPICAL APPLICATIONS

controlled, preventing any damaging effects of inrush current. Proper heat sinking of the package is required in this application as the die may dissipate 100mW to 200mW during initial charging. When V_{OUT} is greater than $\sim 3.5V$, normal boost mode operation and efficiency begin, with the P-channel MOSFET acting as a synchronous switch. Average input current is a constant 50mA during charging, where the current delivered to the SuperCap varies somewhat with duty cycle. Once the SuperCap is charged to 5V, the LTC3459 begins to regulate and the input current is reduced to the amount required to support the load and/or self discharge of the SuperCap.

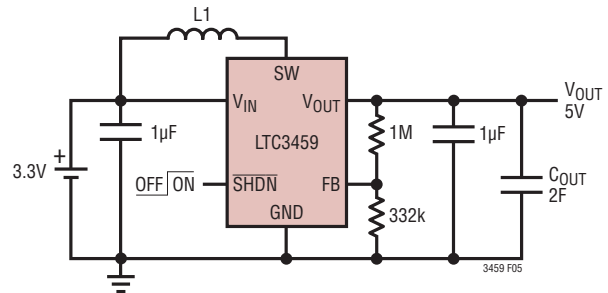

C_{OUT} : MAXWELL TECHNOLOGIES ULTRACAP PC5-5, 2F, 5V
 $L1$: 33μH, 1.7Ω TAIYO YUDEN LB2016

Figure 5. Charging a SuperCap from a 3.3V Source

PACKAGE DESCRIPTION

DC Package 6-Lead Plastic DFN (2mm × 2mm) (Reference LTC DWG # 05-08-1703)

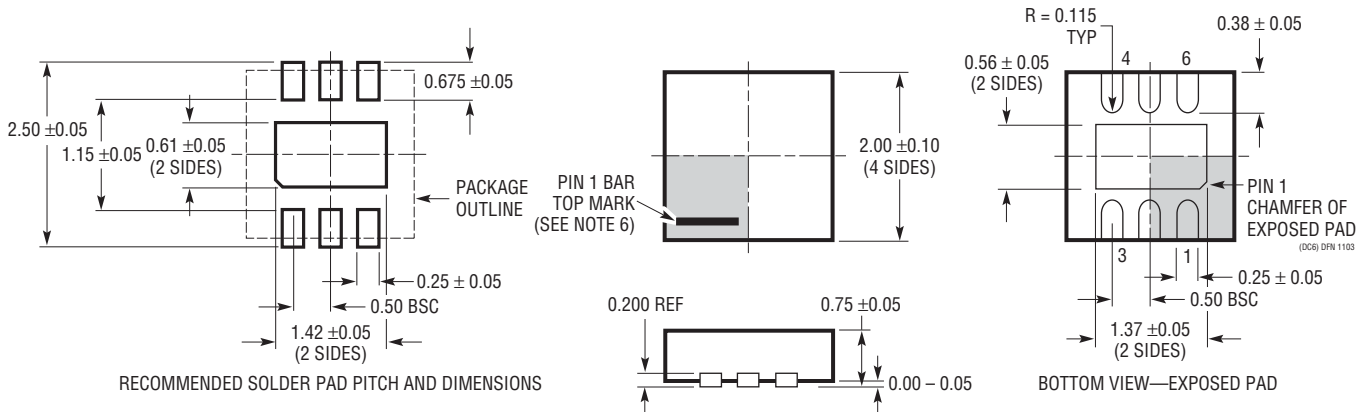

- NOTE:
1. DRAWING TO BE MADE A JEDEC PACKAGE OUTLINE M0-229 VARIATION OF (WCCD-2)
 2. DRAWING NOT TO SCALE
 3. ALL DIMENSIONS ARE IN MILLIMETERS
 4. DIMENSIONS OF EXPOSED PAD ON BOTTOM OF PACKAGE DO NOT INCLUDE MOLD FLASH. MOLD FLASH, IF PRESENT, SHALL NOT EXCEED 0.15mm ON ANY SIDE
 5. EXPOSED PAD SHALL BE SOLDER PLATED
 6. SHADED AREA IS ONLY A REFERENCE FOR PIN 1 LOCATION ON THE TOP AND BOTTOM OF PACKAGE

PACKAGE DESCRIPTION

DCB Package 6-Lead Plastic DFN (2mm × 3mm) (Reference LTC DWG # 05-08-1715)

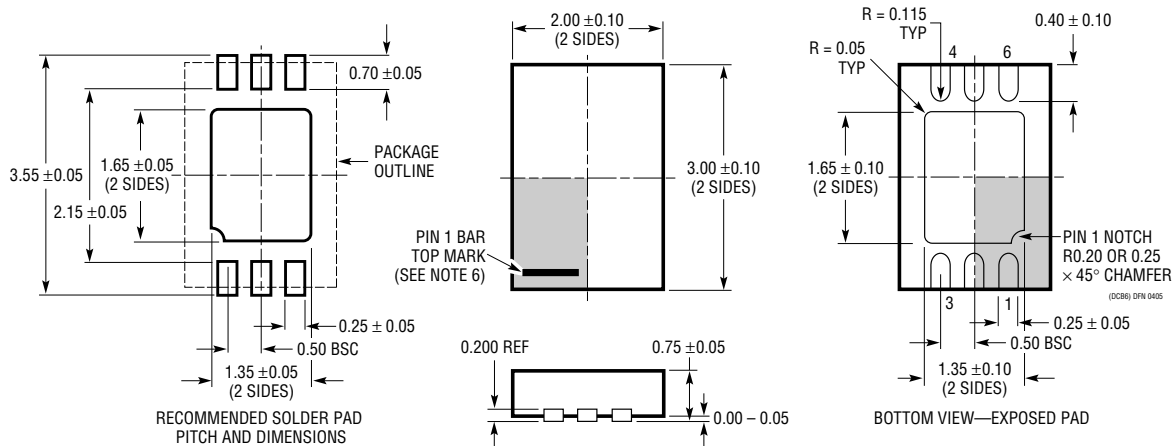

- NOTE:
- DRAWING TO BE MADE A JEDEC PACKAGE OUTLINE M0-229 VARIATION OF (TBD)
 - DRAWING NOT TO SCALE
 - ALL DIMENSIONS ARE IN MILLIMETERS
 - DIMENSIONS OF EXPOSED PAD ON BOTTOM OF PACKAGE DO NOT INCLUDE MOLD FLASH. MOLD FLASH, IF PRESENT, SHALL NOT EXCEED 0.15mm ON ANY SIDE
 - EXPOSED PAD SHALL BE SOLDER PLATED
 - SHADED AREA IS ONLY A REFERENCE FOR PIN 1 LOCATION ON THE TOP AND BOTTOM OF PACKAGE

S6 Package 6-Lead Plastic TSOT-23 (Reference LTC DWG # 05-08-1636)

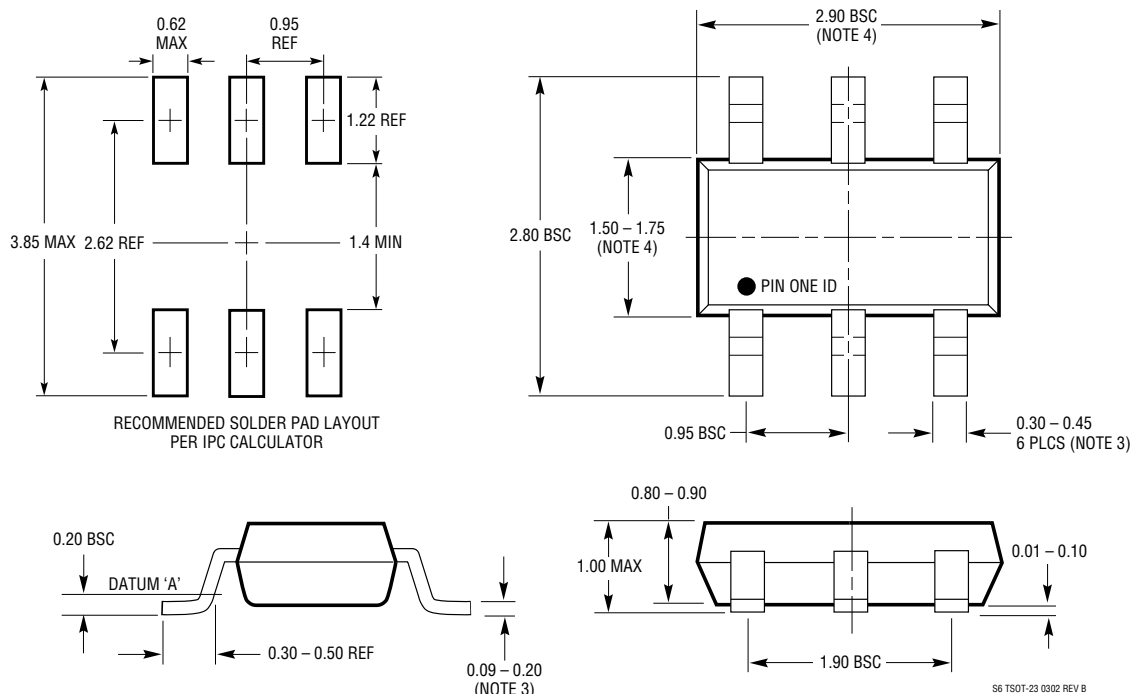

- NOTE:
- DIMENSIONS ARE IN MILLIMETERS
 - DRAWING NOT TO SCALE
 - DIMENSIONS ARE INCLUSIVE OF PLATING
 - DIMENSIONS ARE EXCLUSIVE OF MOLD FLASH AND METAL BURR
 - MOLD FLASH SHALL NOT EXCEED 0.254mm
 - JEDEC PACKAGE REFERENCE IS M0-193

S6 TSOT-23 0302 REV B

TYPICAL APPLICATION

3.3V from a 2 AA Alkaline Input

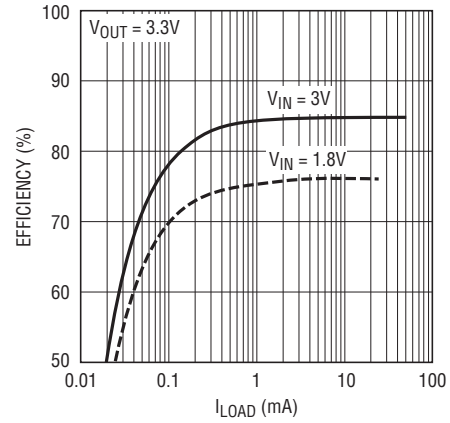
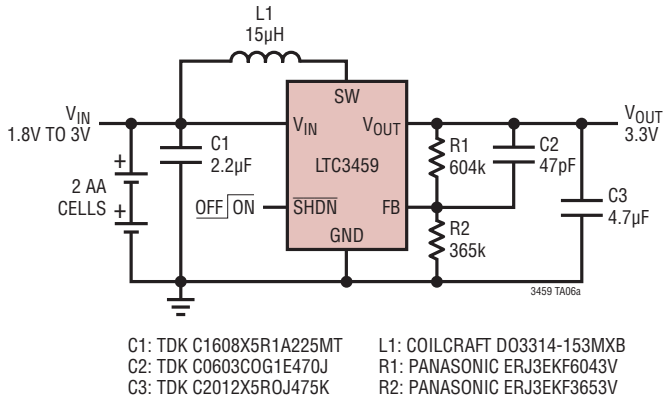

RELATED PARTS

PART NUMBER	DESCRIPTION	COMMENTS
LT1310	1.5A I _{SW} , 4.5MHz, High Efficiency Step-Up DC/DC Converter	V _{IN} : 2.75V to 18V, V _{OUT(MAX)} = 35V, I _Q = 12mA, I _{SD} < 1µA, MS10E
LT1613	550mA I _{SW} , 1.4MHz, High Efficiency Step-Up DC/DC Converter	V _{IN} : 0.9V to 10V, V _{OUT(MAX)} = 34V, I _Q = 3mA, I _{SD} < 1µA, ThinSOT
LT1615/ LT1615-1	300mA/80mA I _{SW} , Constant Off-Time, High Efficiency Step-Up DC/DC Converter	V _{IN} : 1.2V to 15V, V _{OUT(MAX)} = 34V, I _Q = 20µA, I _{SD} < 1µA, ThinSOT
LT1618	1.5A I _{SW} , 1.4MHz, High Efficiency Step-Up DC/DC Converter	V _{IN} : 1.6V to 18V, V _{OUT(MAX)} = 35V, I _Q = 1.8mA, I _{SD} < 1µA, MS10
LT1944 (Dual)	Dual Output 350mA I _{SW} , Constant Off-Time, High Efficiency Step-Up DC/DC Converter	V _{IN} : 1.2V to 15V, V _{OUT(MAX)} = 34V, I _Q = 20µA, I _{SD} < 1µA, MS10
LT1945 (Dual)	Dual Output Pos/Neg 350mA I _{SW} , Constant Off-Time, High Efficiency Step-Up DC/DC Converter	V _{IN} : 1.2V to 15V, V _{OUT(MAX)} = ±34V, I _Q = 20µA, I _{SD} < 1µA, MS10
LT1946/ LT1946A	1.5A I _{SW} , 1.2MHz/2.7MHz, High Efficiency Step-Up DC/DC Converter	V _{IN} : 2.45V to 16V, V _{OUT(MAX)} = 34V, I _Q = 3.2mA, I _{SD} < 1µA, MS8
LT1949/ LT1949-1	550mA I _{SW} , 600kHz/1.1MHz, High Efficiency Step-Up DC/DC Converter	V _{IN} : 1.5V to 12V, V _{OUT(MAX)} = 28V, I _Q = 4.5mA, I _{SD} < 25µA, SO-8, MS8
LT1961	1.5A I _{SW} , 1.25MHz, High Efficiency Step-Up DC/DC Converter	V _{IN} : 3V to 25V, V _{OUT(MAX)} = 35V, I _Q = 0.9mA, I _{SD} < 6µA, MS8E
LTC3400/ LTC3400B	600mA I _{SW} , 1.2MHz, Synchronous Step-Up DC/DC Converter	V _{IN} : 0.5V to 5V, V _{OUT(MAX)} = 5V, I _Q = 19µA/300µA, I _{SD} < 1µA, ThinSOT
LTC3401	1A I _{SW} , 3MHz, Synchronous Step-Up DC/DC Converter	V _{IN} : 0.5V to 5V, V _{OUT(MAX)} = 6V, I _Q = 38µA, I _{SD} < 1µA, MS10
LTC3402	2A I _{SW} , 3MHz, Synchronous Step-Up DC/DC Converter	V _{IN} : 0.5V to 5V, V _{OUT(MAX)} = 6V, I _Q = 38µA, I _{SD} < 1µA, MS10
LTC3425	5A I _{SW} , 8MHz, 4-Phase Synchronous Step-Up DC/DC Converter, QFN32	V _{IN} : 0.5V to 4.5V, V _{OUT(MAX)} = 5.25V, I _Q = 12µA, I _{SD} < 1µA,
LTC3429	600mA, 500kHz, Synchronous Step-Up DC/DC Converter with Output Disconnect and Soft-Start	V _{IN} : 0.5V to 5V, V _{OUT(MAX)} = 5V, I _Q = 20µA/300µA, I _{SD} < 1µA, ThinSOT
LT3460	320mA I _{SW} , 1.3MHz, High Efficiency Step-Up DC/DC Converter	V _{IN} : 0.5V to 5V, V _{OUT(MAX)} = 5V, I _Q = 20µA/300µA, I _{SD} < 1µA, ThinSOT
LT3464	85mA I _{SW} , Constant Off-Time, High Efficiency Step-Up DC/DC Converter with Integrated Schottky/Output Disconnect	V _{IN} : 2.3V to 10V, V _{OUT(MAX)} = 34V, I _Q = 25µA, I _{SD} < 1µA, ThinSOT