



High-Voltage, Step-Down Controller with Synchronous Rectifier for CPU Power

General Description

The MAX797H high-performance, step-down DC-DC converter provides main CPU power in battery-powered systems. A 40V rating on the power stage's input allows operation with high-cell-count batteries and a wide range of AC adaptors. This buck controller achieves 96% efficiency by using synchronous rectification and Maxim's proprietary Idle Mode™ control scheme to extend battery life at full-load (up to 10A) and no-load outputs. Excellent dynamic response corrects output transients caused by the latest dynamic-clock CPUs within five 300kHz clock cycles. Unique bootstrap circuitry drives inexpensive N-channel MOSFETs, reducing system cost and eliminating the crowbar switching currents found in some PMOS/NMOS switch designs.

The MAX797H has a logic-controlled and synchronizable fixed-frequency, pulse-width-modulating (PWM) operating mode, which reduces noise and RF interference in sensitive mobile-communications and pen-entry applications. The SKIP override input allows automatic switchover to idle-mode operation (for high-efficiency pulse skipping) at light loads, or forces fixed-frequency mode for lowest noise at all loads. The MAX797H is pin compatible with the popular MAX797, but has a higher input voltage range.

The MAX797H comes in a 16-pin narrow SO package.

Applications

Notebook and Subnotebook Computers
Industrial Controls

Pin Configuration

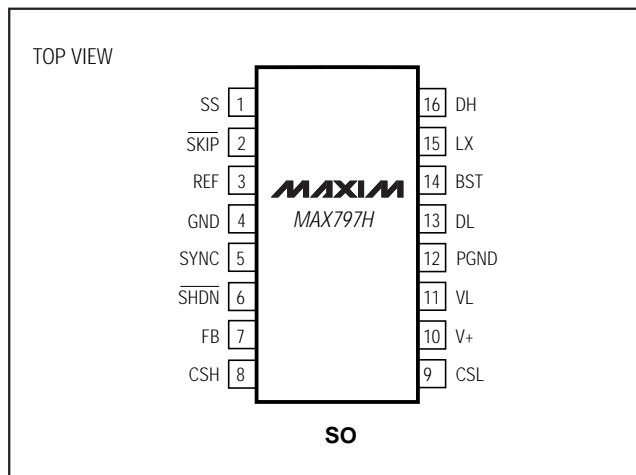

Idle Mode is a trademark of Maxim Integrated Products.

Features

- ◆ 96% Efficiency
- ◆ Up to 40V Power Input
- ◆ 2.5V to 6V Adjustable Output
- ◆ Preset 3.3V and 5V Outputs (at up to 10A)
- ◆ 5V Linear-Regulator Output
- ◆ Precision 2.505V Reference Output
- ◆ Automatic Bootstrap Circuit
- ◆ 150kHz/300kHz Fixed-Frequency PWM Operation
- ◆ Programmable Soft-Start
- ◆ 375µA Quiescent Current ($V_{IN} = 12V$, $V_{OUT} = 5V$)
- ◆ 1µA Shutdown Current

Ordering Information

PART	TEMP. RANGE	PIN-PACKAGE
MAX797HESE	-40°C to +85°C	16 Narrow SO

Typical Operating Circuit

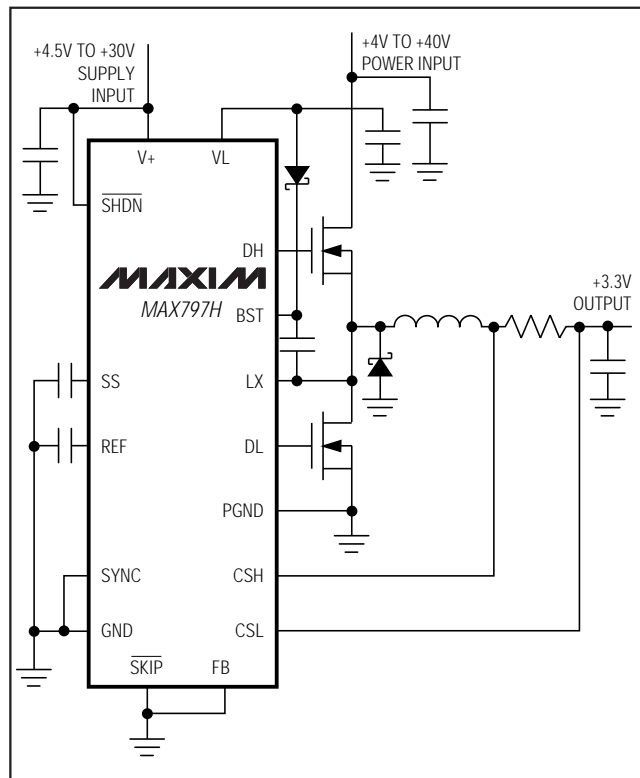

High-Voltage, Step-Down Controller with Synchronous Rectifier for CPU Power

ABSOLUTE MAXIMUM RATINGS

V+ to GND	-0.3V to 36V	VL Short Circuit to GND	Momentary
GND to PGND	±2V	REF Short Circuit to GND	Continuous
VL to GND	-0.3V to 7V	VL Output Current	50mA
BST to GND	-0.3V to 46V	Continuous Power Dissipation (T _A = +70°C)	
DH to LX	-0.3V to (BST + 0.3V)	SO (derate 8.70mW/°C above +70°C)	696mW
LX to BST	-7V to 0.3V	Operating Temperature Range	
SHDN to GND	-0.3V to 36V	MAX797HESE	-40°C to +85°C
SYNC, SS, REF, FB, SKIP, DL to GND	-0.3V to (VL + 0.3V)	Storage Temperature Range	-65°C to +160°C
CSH, CSL to GND	-0.3V to 7V	Lead Temperature (soldering, 10sec)	+300°C

Stresses beyond those listed under "Absolute Maximum Ratings" may cause permanent damage to the device. These are stress ratings only, and functional operation of the device at these or any other conditions beyond those indicated in the operational sections of the specifications is not implied. Exposure to absolute maximum rating conditions for extended periods may affect device reliability.

ELECTRICAL CHARACTERISTICS

(V+ = 15V, GND = PGND = 0V, I_{VL} = I_{REF} = 0A, T_A = 0°C to +85°C, SYNC = 0V, unless otherwise noted.)

PARAMETER	CONDITIONS	MIN	TYP	MAX	UNITS
+3.3V AND +5V STEP-DOWN CONTROLLERS					
Input Supply Range	V+	4.5		30	V
	High-side MOSFET drain			40	
5V Output Voltage (CSL)	0mV < (CSH - CSL) < 80mV, FB = VL, 6V < power input < 40V, includes line and load regulation (Note 4)	4.85	5.10	5.25	V
3.3V Output Voltage (CSL)	0mV < (CSH - CSL) < 80mV, FB = 0V, 4.5V < power input < 40V, includes line and load regulation (Note 4)	3.20	3.35	3.46	V
Nominal Adjustable Output Voltage Range	External resistor divider	REF		6	V
Feedback Voltage	CSH - CSL = 0V	2.43	2.505	2.57	V
Load Regulation	0mV < (CSH - CSL) < 80mV		2.5		%
	25mV < (CSH - CSL) < 80mV		1.5		
Line Regulation	FB = VL, 6V < power input < 40V (Note 4)		0.04	0.06	%V
	FB = 0V, 4.5V < power input < 40V (Note 4)		0.04	0.06	
Current-Limit Voltage	CSH - CSL, positive	80	100	120	mV
	CSH - CSL, negative	-50	-100	-160	
SS Source Current		2.5	4.0	6.5	µA
SS Fault Sink Current		2.0			mA
INTERNAL REGULATOR AND REFERENCE					
VL Output Voltage	SHDN = 2V, 0mA < I _{VL} < 25mA, 5.5V < V+ < 30V	4.7		5.3	V
VL Fault Lockout Voltage	Rising edge, hysteresis = 15mV	3.8		4.1	V
VL/CSL Switchover Voltage	Rising edge, hysteresis = 25mV	4.2		4.7	V

High-Voltage, Step-Down Controller with Synchronous Rectifier for CPU Power

MAX797H

ELECTRICAL CHARACTERISTICS (continued)

(V+ = 15V, GND = PGND = 0V, I_{VL} = I_{REF} = 0A, T_A = 0°C to +85°C, SYNC = 0V, unless otherwise noted.)

PARAMETER	CONDITIONS	MIN	TYP	MAX	UNITS
Reference Output Voltage	No external load (Note 1)	2.45	2.505	2.55	V
Reference Fault Lockout Voltage	Falling edge	1.8		2.3	V
Reference Load Regulation	0μA < I _{REF} < 100μA			50	mV
CSL Shutdown Leakage Current	$\overline{\text{SHDN}} = 0\text{V}$, CSL = 6V, V+ = 0V or 30V, VL = 0V		0.1	1	μA
V+ Shutdown Current	$\overline{\text{SHDN}} = 0\text{V}$, V+ = 30V, CSL = 0V or 6V		1	5	μA
V+ Off-State Leakage Current	FB = CSH = CSL = 6V, VL switched over to CSL		1	5	μA
Dropout Power Consumption	V+ = 4V, CSL = 0V (Note 2)		4	8	mW
Quiescent Power Consumption	CSH = CSL = 6V		4.8	6.6	mW
OSCILLATOR AND INPUTS/OUTPUTS					
Oscillator Frequency	SYNC = REF	270	300	330	kHz
	SYNC = 0V or 5V	125	150	175	
SYNC High Pulse Width		200			ns
SYNC Low Pulse Width		200			ns
SYNC Rise/Fall Time	Guaranteed by design			200	ns
Oscillator Sync Range		190		340	kHz
Maximum Duty Factor	SYNC = REF	89	91		%
	SYNC = 0V or 5V	93	96		
Input High Voltage	SYNC	VL - 0.5			V
	$\overline{\text{SHDN}}$, $\overline{\text{SKIP}}$	2.0			
Input Low Voltage	SYNC	0.8			V
	$\overline{\text{SHDN}}$, $\overline{\text{SKIP}}$	0.5			
Input Current	$\overline{\text{SHDN}}$, 0V or 30V	2.0			μA
	SYNC, $\overline{\text{SKIP}}$	1.0			
	CSH, CSL, CSH = CSL = 4V, device not shut down	50			
	FB, FB = REF	±100			
DL Sink/Source Current	DL forced to 2V		1		A
DH Sink/Source Current	DH forced to 2V, BST - LX = 4.5V		1		A
DL On-Resistance	High or low			7	Ω
DH On-Resistance	High or low, BST - LX = 4.5V			7	Ω

High-Voltage, Step-Down Controller with Synchronous Rectifier for CPU Power

ELECTRICAL CHARACTERISTICS (continued)

(V+ = 15V, GND = PGND = 0V, I_{VL} = I_{REF} = 0A, T_A = -40 to +85°C, SYNC = 0V, unless otherwise noted.) (Note 3)

PARAMETER	CONDITIONS	MIN	TYP	MAX	UNITS
+3.3V and +5V STEP-DOWN CONTROLLERS					
Input Supply Range	V+	5.0		30	V
	High-side MOSFET drain			40	
5V Output Voltage (CSL)	0mV < (CSH - CSL) < 80mV, FB = VL, 6V < power input < 40V, includes line and load regulation (Note 4)	4.70	5.10	5.40	V
3.3V Output Voltage (CSL)	0mV < (CSH - CSL) < 80mV, FB = 0V, 4.5V < power input < 40V, includes line and load regulation (Note 4)	3.10	3.35	3.56	V
Nominal Adjustable Output Voltage Range	External resistor divider	REF		6.0	V
Feedback Voltage	CSH - CSL = 0V	2.40		2.60	V
Line Regulation	FB = VL, 6V < power input < 40V (Note 4)		0.04	0.06	%V
	FB = 0V, 4.5V < power input < 40V (Note 4)		0.04	0.06	
Current-Limit Voltage	CSH - CSL, positive	70		130	mV
	CSH - CSL, negative	-40	-100	-160	
INTERNAL REGULATOR AND REFERENCE					
VL Output Voltage	$\overline{\text{SHDN}} = 2\text{V}$, 0mA < I _{VL} < 25mA, 5.5V < V+ < 30V	4.7		5.3	V
VL Fault Lockout Voltage	Rising edge, hysteresis = 15mV	3.75		4.15	V
VL/CSL Switchover Voltage	Rising edge, hysteresis = 25mV	4.2		4.7	V
Reference Output Voltage	No external load (Note 1)	2.43	2.505	2.57	V
Reference Load Regulation	0μA < I _{REF} < 100μA			50	mV
V+ Shutdown Current	$\overline{\text{SHDN}} = 0\text{V}$, V+ = 30V, CSL = 0V or 6V		1	10	μA
V+ Off-State Leakage Current	FB = CSH = CSL = 6V, VL switched over to CSL		1	10	μA
Quiescent Power Consumption	CSH = CSL = 6V		4.8	8.4	mW
OSCILLATOR AND INPUTS/OUTPUTS					
Oscillator Frequency	SYNC = REF	250	300	350	kHz
	SYNC = 0V or 5V	120	150	180	
SYNC High Pulse Width		250			ns
SYNC Low Pulse Width		250			ns
Oscillator Sync Range		210		320	kHz
Maximum Duty Factor	SYNC = REF	89	91		%
	SYNC = 0V or 5V	93	96		
DL On-Resistance	High or low			7	Ω
DH On-Resistance	High or low, BST - LX = 4.5V			7	Ω

Note 1: Since the reference uses VL as its supply, V+ line-regulation error is insignificant.

Note 2: At very low input voltages, quiescent supply current can increase due to excess PNP base current in the VL linear regulator. This occurs only if V+ falls below the preset VL regulation point (5V nominal).

Note 3: All -40°C to +85°C specifications are guaranteed by design.

Note 4: The power input is the high-side MOSFET drain.

High-Voltage, Step-Down Controller with Synchronous Rectifier for CPU Power

Pin Description

MAX797H

PIN	NAME	FUNCTION
1	SS	Soft-Start Timing Capacitor Connection. Ramp time to full current limit is approximately 1ms/nF.
2	$\overline{\text{SKIP}}$	Disables pulse-skipping mode when high. Connect $\overline{\text{SKIP}}$ to GND for normal use. Do not leave unconnected. With $\overline{\text{SKIP}}$ grounded, the device <i>automatically</i> changes from pulse-skipping operation to full PWM operation when the load current exceeds approximately 30% of maximum.
3	REF	Reference Voltage Output. Bypass REF to GND with 0.33 μ F minimum.
4	GND	Low-noise Analog Ground and Feedback Reference Point
5	SYNC	Oscillator Synchronization and Frequency Select. Tie SYNC to GND or VL for 150kHz operation; tie to REF for 300kHz operation. A high-to-low transition begins a new cycle. Drive SYNC with 0V to 5V logic levels (see <i>Electrical Characteristics</i> for V_{IH} and V_{IL} specifications). SYNC capture range is guaranteed to be 190kHz to 340kHz.
6	$\overline{\text{SHDN}}$	Shutdown Control Input, Active Low. Logic threshold is set at approximately 1V (V_{TH} of an internal N-channel MOSFET). Tie $\overline{\text{SHDN}}$ to V+ for automatic start-up.
7	FB	Feedback Input. Regulates at FB = REF (approximately 2.505V) in adjustable mode. FB is a Dual Mode™ input that also selects the fixed-output voltage settings as follows: <ul style="list-style-type: none"> • Connect to GND for 3.3V operation. • Connect to VL for 5V operation. • Connect to a resistor divider for adjustable mode. FB can be driven with 5V Rail-to-Rail® logic to change the output voltage under system control.
8	CSH	Current-Sense Input, High Side. Current-limit level is 100mV referred to CSL.
9	CSL	Current-Sense Input, Low Side. CSL also serves as the feedback input in fixed-output modes.
10	V+	Battery Voltage Input (4.5V to 30V). Bypass V+ to PGND close to the IC with a 0.1 μ F capacitor. Connects to a linear regulator that powers VL.
11	VL	5V Internal Linear-Regulator Output. VL is also the supply-voltage rail for the chip. It is switched to the output voltage via CSL ($V_{CSL} > 4.5V$) for automatic bootstrapping. Bypass to GND with 4.7 μ F. VL can supply up to 5mA for external loads.
12	PGND	Power Ground
13	DL	Low-Side Gate-Drive Output. DL normally drives the synchronous-rectifier MOSFET. Swings 0V to VL.
14	BST	Boost Capacitor Connection for High-Side Gate Drive (0.1 μ F)
15	LX	Switching Node (inductor) Connection. LX can swing 2V below ground without hazard.
16	DH	High-Side Gate-Drive Output. DH normally drives the main buck switch. It is a floating driver output that swings from LX to BST, riding on the LX switching-node voltage.

Dual Mode is a trademark of Maxim Integrated Products.

Rail-to-Rail is a registered trademark of Nippon Motorola Ltd.

High-Voltage, Step-Down Controller with Synchronous Rectifier for CPU Power

Detailed Description

The MAX797H is functionally identical to the MAX797. The only difference between the two devices is in the BST pin's absolute maximum rating. The MAX797H's rating is 46V; the MAX797's rating is 36V. The higher rating allows the MAX797H to use a power input up to 40V, provided that the V+ pin is powered by a separate supply between 4.5V and 30V.

Circuit design and component selection for the MAX797H are identical to those for the MAX797; therefore, such information is not included in this data sheet. Refer to the MAX796/MAX797/MAX799 data sheet for design formulas and applications information. The *Applications Information* section in this data sheet contains suggestions for providing the 30V maximum V+ supply input for the MAX797H when power input exceeds 30V.

Applications Information

Powering the V+ Pin

V+ can be supplied directly if a system supply between 4.5V and 30V is available (see the *Typical Operating Circuit*). Most of the MAX797H's internal blocks are supplied by VL, which uses V+ as its input. While the current into V+ is minimal, it depends heavily on the type of external MOSFET used and the switching frequency:

$$I_{GATE} = Q_g \times f_{SW}$$

where Q_g is the sum of the high- and low-side MOSFET's total gate charges, and f_{SW} is the switching frequency. Furthermore, if the circuit output voltage on CSL exceeds the VL/CSL switchover voltage, the MAX797H bootstraps itself (it connects VL to CSL and turns off the linear regulator, supplying the IC from the circuit output), and V+ current is reduced to about 1 μ A.

If a 5V regulated supply is available, V+ and VL can be connected and fed from that supply (Figure 1). In this mode, the VL regulator is bypassed. Do not use this approach if the output voltage on CSL can exceed the VL/CSL switchover voltage.

If a 5V regulated supply is not available, a linear regulator with a sufficient input voltage range can provide it (Figure 2). This approach allows for a very wide input voltage range, which is useful if the circuit must run from several different power sources. The drawback of the linear regulator is the high quiescent current that these devices typically require, in addition to the current used by the feedback divider resistors (R1 and R2).

For most applications, a better choice than Figure 2's circuit takes advantage of the MAX797H's internal linear regulator. There is no need to provide a regulated supply to V+, provided it is within the +4.5V to +30V V+ input voltage range. In Figure 3, Q1 is used to drop a 40V (max) input to 30V by dividing it by approximately 4/3. This approach results in a somewhat higher minimum input voltage than that of Figure 2's circuit, but a much lower quiescent current than that of a linear regulator. If quiescent current must be minimized, an N-channel MOSFET can be substituted for Q1, and the divider-resistor values can be increased.

Powering V+ with a zener diode can be done in many different ways. The simplest is to use a standard shunt regulator to provide a regulated voltage in the 4.5V to 30V range (Figure 4). Resistor R1 must be chosen to allow the maximum required V+ current to be obtained from the minimum power input voltage. If the power input voltage varies appreciably, the result is higher-than-necessary input current from the highest power input voltage. An approach that reduces quiescent current is to use a zener diode as a dropping diode to keep V+ under 30V (Figure 5). This results in a severely restricted minimum range for the power input voltage, which is not a problem for most high-voltage applications. RL must be added to draw current and to ensure that there is sufficient forward drop across the zener diode if the MAX797H can be shut down or bootstrap off its output voltage.

Duty-Factor Limitations for Low V_{OUT}/V_{IN} Ratios

The MAX797H's output voltage is adjustable down to 2.5V (min). However, the combination of high input and low output voltages may not be possible at high switching frequencies without introducing some amount of frequency instability. The minimum duty factor is determined by delays through the error comparator, internal logic, gate drivers, and external MOSFETs. The delay is typically 425ns. With a switching period of 3.33 μ s (300kHz), the minimum duty factor is $0.425 \mu\text{s} / 3.33 \mu\text{s} = 0.13$. If V_{OUT} / V_{IN} is less than this value, the IC will properly regulate the output voltage, but may extend the period and switch at 150kHz instead of 300kHz. It may also alternate between these two frequencies. For example, if V_{IN} is 40V, the lowest V_{OUT} that does not require less than the minimum duty factor is $40\text{V} \times 0.13 = 5.2\text{V}$. Below this output voltage, select the 150kHz switching frequency (connect SYNC to VL or GND).

High-Voltage, Step-Down Controller with Synchronous Rectifier for CPU Power

MAX797H

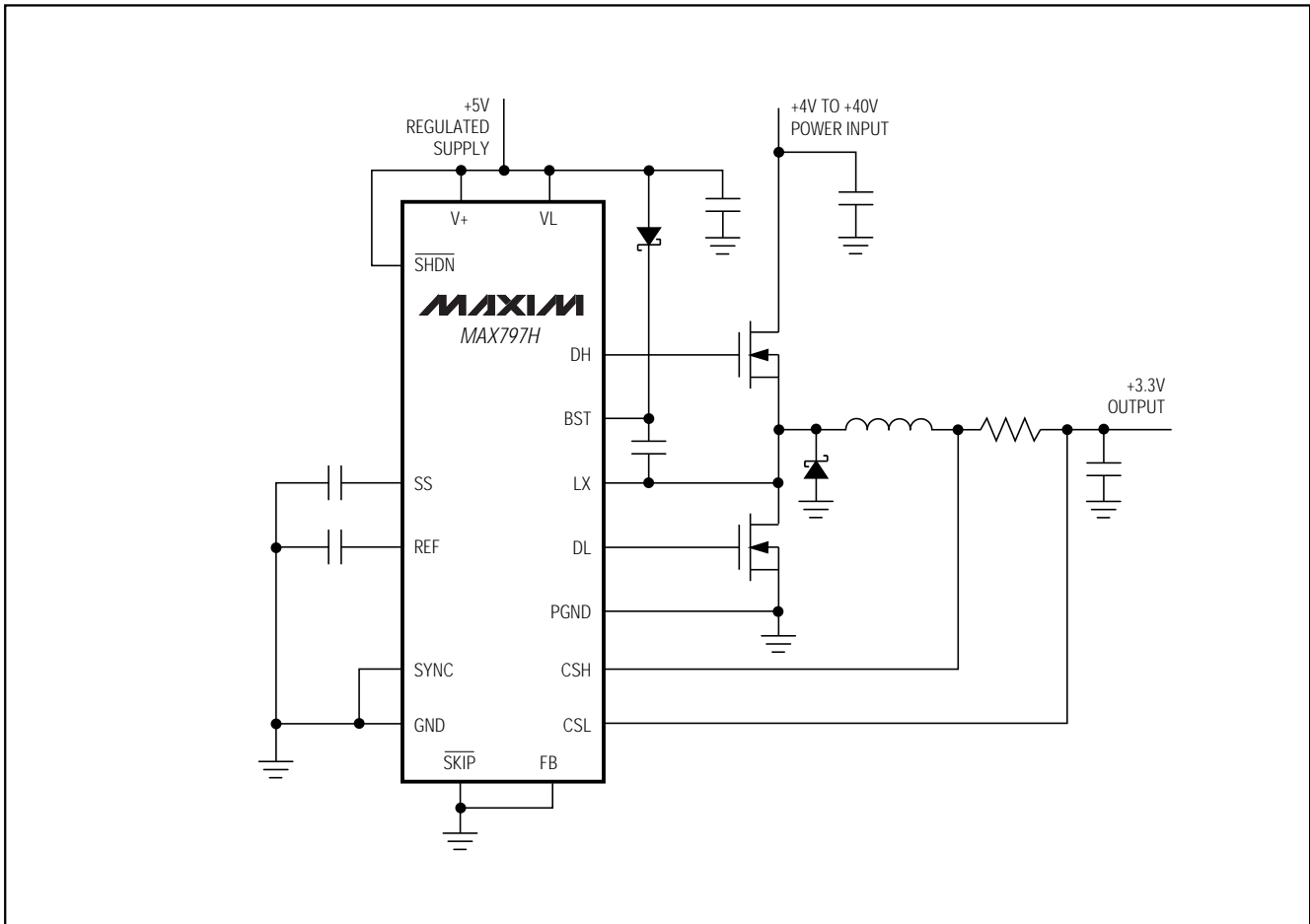

Figure 1. Powering V+ and VL from a Regulated +5V supply

Similarly, at 150kHz, the minimum duty factor is $0.425\mu\text{s} / 6.67\mu\text{s} = 0.064$. This means that duty factor is not an issue except at the maximum input voltage and minimum output voltage. For example, if V_{IN} is 40V, the lowest V_{OUT} that does not require less than the

minimum duty factor is $40\text{V} \times 0.064 = 2.56\text{V}$. If V_{OUT} / V_{IN} is less than this value, the IC will properly regulate the output voltage, but may extend the period and switch at 75kHz instead of 150kHz. It may also alter the duty factor between these two frequencies.

High-Voltage, Step-Down Controller with Synchronous Rectifier for CPU Power

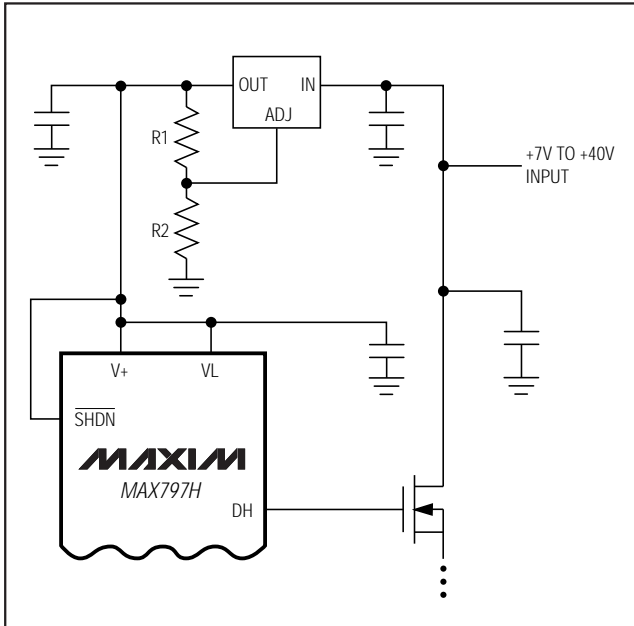

Figure 2. Powering V+ and VL with a +5V Linear Regulator

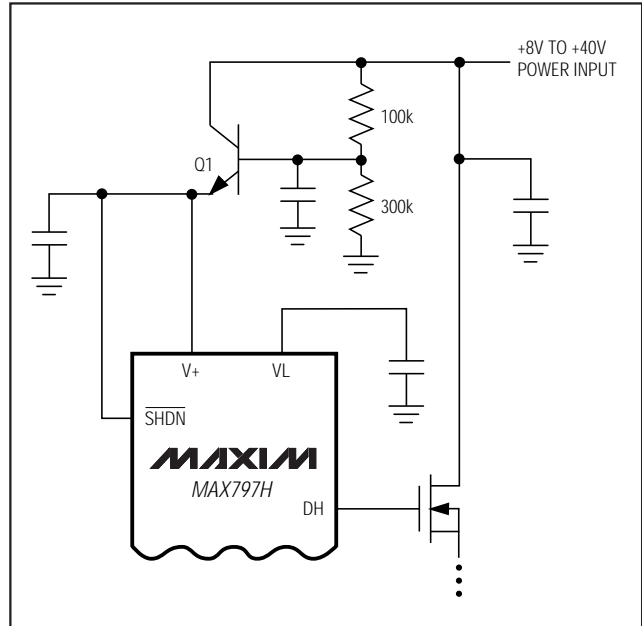

Figure 3. Dividing the Power Input to Supply V+

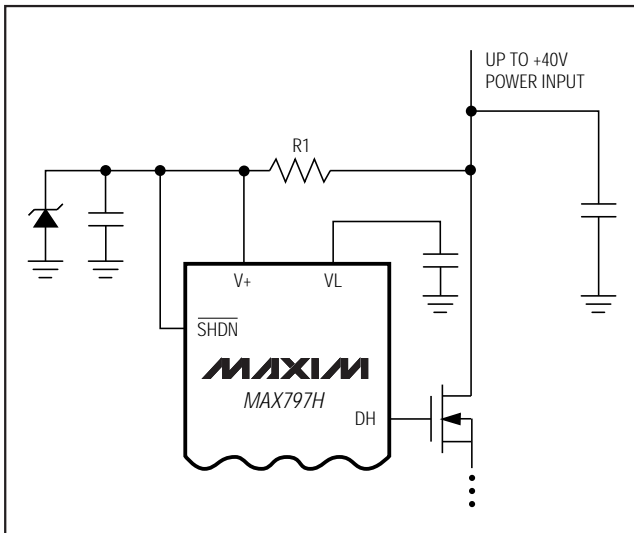

Figure 4. Powering V+ with a Zener Shunt Regulator

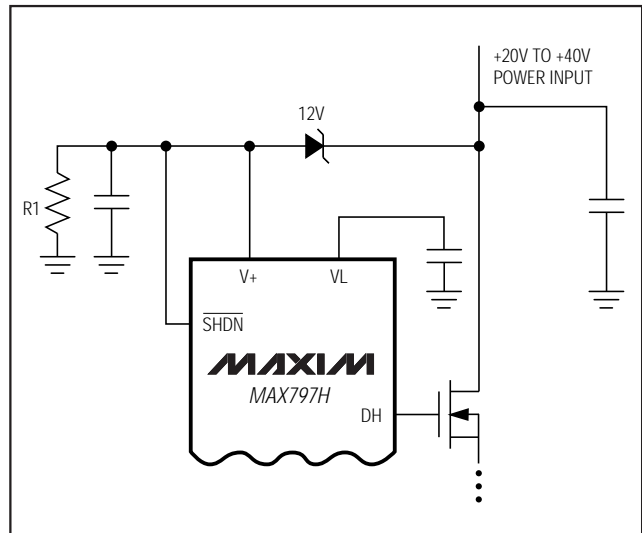

Figure 5. Powering V+ with a Zener Dropping Diode

Chip Information

TRANSISTOR COUNT: 913

Maxim cannot assume responsibility for use of any circuitry other than circuitry entirely embodied in a Maxim product. No circuitry or patent licenses are implied. Maxim reserves the right to change the circuitry and specifications without notice at any time.

8 Maxim Integrated Products, 120 San Gabriel Drive, Sunnyvale, CA 94086 (408) 737-7600

© 1997 Maxim Integrated Products

Printed USA

MAXIM is a registered trademark of Maxim Integrated Products.