



Low Supply Current, Step-Up DC-DC Converters with True-Shutdown

MAX1795/MAX1796/MAX1797

General Description

The MAX1795/MAX1796/MAX1797 are high efficiency step-up DC-DC converters intended for small portable hand-held devices. These devices feature Maxim's True-Shutdown™ circuitry, which fully disconnects the output from the input in shutdown, improves efficiency, and eliminates costly external components. All three devices also feature Maxim's proprietary LX-damping circuitry for reduced EMI in noise-sensitive applications. For additional in-system flexibility, a battery monitoring comparator (LBI/LBO) remains active even when the DC-DC converter is in shutdown.

The input voltage range is +0.7V to V_{OUT} , where V_{OUT} can be set from +2V to +5.5V. Startup is guaranteed from +0.85V. The MAX1795/MAX1796/MAX1797 have a preset, pin-selectable 5V or 3.3V output. The output can also be adjusted to other voltages, using two external resistors. The three devices differ only in their current limits, allowing optimization of external components for different loads: The MAX1795, MAX1796, and MAX1797 have current limits of 0.25A, 0.5A, and 1A, respectively. All devices are packaged in a compact 8-pin μ MAX package that is only 1.09mm tall and half the size of an 8-pin SO.

Applications

- Portable Digital Audio Players
- PDA's/Palmtops
- Wireless Handsets
- Portable Terminals

Pin Configuration

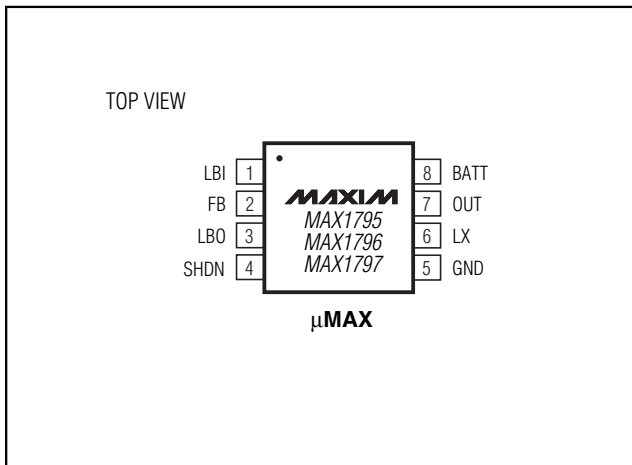

Features

- ◆ >95% Efficiency
- ◆ True-Shutdown Circuitry
 - Output Disconnects from Input in Shutdown
 - No External Schottky Diode Needed
- ◆ 25 μ A Quiescent Supply Current
- ◆ Low-Noise Antiringing Feature
- ◆ LBI/LBO Comparator Enabled in Shutdown
- ◆ 2 μ A Shutdown Current
- ◆ 8-Pin μ MAX Package

Ordering Information

PART	TEMP. RANGE	PIN-PACKAGE
MAX1795EUA	-40°C to +85°C	8 μ MAX
MAX1796EUA	-40°C to +85°C	8 μ MAX
MAX1797EUA	-40°C to +85°C	8 μ MAX

True-Shutdown is a trademark of Maxim Integrated Products.

Typical Operating Circuit

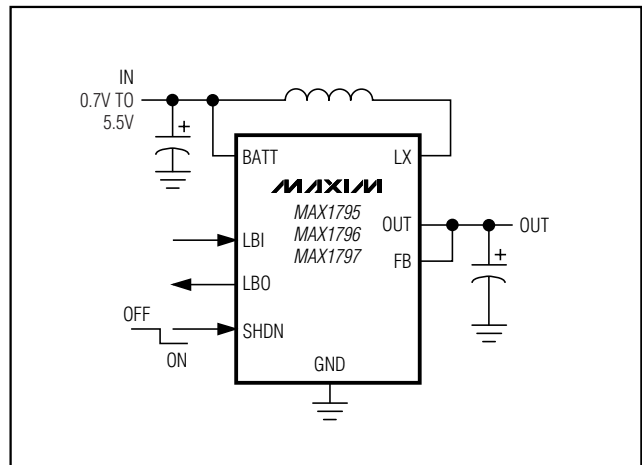

For price, delivery, and to place orders, please contact Maxim Distribution at 1-888-629-4642, or visit Maxim's website at www.maxim-ic.com.

Low Supply Current, Step-Up DC-DC Converters with True-Shutdown

ABSOLUTE MAXIMUM RATINGS

OUT, LX, SHDN, LBI, LBO, BATT to GND.....-0.3V to +6V
 FB-0.3V to (V_{OUT} + 0.3V)
 I_{LX}, I_{OUT}.....±1.5A
 Output Short-Circuit Duration5s
 Continuous Power Dissipation
 8-Pin μMAX (derate 4.1mW/°C above +70°C).....330mW

Operating Temperature Range-40°C to +85°C
 Junction Temperature+150°C
 Storage Temperature Range-65°C to +150°C
 Lead Temperature (soldering, 10s)+300°C

Stresses beyond those listed under "Absolute Maximum Ratings" may cause permanent damage to the device. These are stress ratings only, and functional operation of the device at these or any other conditions beyond those indicated in the operational sections of the specifications is not implied. Exposure to absolute maximum rating conditions for extended periods may affect device reliability.

ELECTRICAL CHARACTERISTICS

(V_{BATT} = +2V, OUT = FB (V_{OUT} = +3.3V), SHDN = LBI = GND, T_A = 0°C to +85°C, unless otherwise noted. Typical values are at T_A = +25°C.)

PARAMETER	SYMBOL	CONDITIONS		MIN	TYP	MAX	UNITS
Minimum Input Voltage		After startup			0.7		V
Operating Voltage	V _{BATT}	(Note 1)		1.0		5.5	V
Startup Voltage		T _A = +25°C, R _L = 3kΩ			0.85	1.0	V
Startup Voltage Tempco					-2.2		mV/°C
Output Voltage	V _{OUT}	FB = OUT		3.17	3.3	3.43	V
		FB = GND		4.80	5.0	5.20	
Adjustable Output Voltage Range				2.0		5.5	V
Steady-State Output Current	I _{OUT}	BATT = +2V, FB = OUT (V _{OUT} = +3.3V)	MAX1795	100	180		mA
			MAX1796	200	300		
			MAX1797	400	550		
		BATT = +2V, FB = GND (V _{OUT} = +5.0V)	MAX1795	50	120		
			MAX1796	100	200		
			MAX1797	250	370		
Feedback Set-Point Voltage (Adjustable Mode)	V _{FB}	V _{OUT} = +2V to +5.5V		1.20	1.24	1.28	V
Feedback Input Current	I _{FB}	V _{FB} = +1.24V			4	100	nA
Internal NFET, PFET On-Resistance	R _{DSON}	V _{OUT} = +3.3V, I _{LX} = 100mA	NFET		0.17	0.3	Ω
			PFET		0.27	0.45	
LX Switch Current Limit (NFET only)	I _{LIM}	MAX1795		0.2	0.25	0.35	A
		MAX1796		0.4	0.5	0.625	
		MAX1797		0.8	1.0	1.25	
LX Leakage Current	I _{LEAK}	V _{LX} = 0 and +5.5V, V _{OUT} = +5.5V			0.2		μA
Synchronous Rectifier Turn-Off Current Limit					25		mA
Damping Switch On-Resistance	R _{DAMP}			100	200	400	Ω
Operating Current into OUT (Note 2)		V _{FB} = +1.4V			25	45	μA

Low Supply Current, Step-Up DC-DC Converters with True-Shutdown

MAX1795/MAX1796/MAX1797

ELECTRICAL CHARACTERISTICS (continued)

($V_{BATT} = +2V$, $OUT = FB$ ($V_{OUT} = +3.3V$), $SHDN = LBI = GND$, $T_A = 0^{\circ}C$ to $+85^{\circ}C$, unless otherwise noted. Typical values are $T_A = +25^{\circ}C$.)

PARAMETER	SYMBOL	CONDITIONS	MIN	TYP	MAX	UNITS
Operating Current into BATT		$V_{FB} = +1.4V$, $V_{LBI} = +1V$		2	4	μA
Shutdown Current into BATT		$SHDN = BATT$, $V_{LBI} = +1V$		2	4	μA
LX Switch Maximum On-Time	t_{ON}	$V_{FB} = +1V$, if current limit not reached	3	4	5	μs
LX Switch Minimum Off-Time	t_{OFF}	$V_{FB} = +1V$	0.8	1	1.2	μs
LBI Threshold Voltage Falling	V_{LBI}	$V_{BATT} = +2V$	0.8	0.85	0.90	V
		$V_{BATT} = LBI$	0.875	0.925	0.975	
LBI Hysteresis				25		mV
LBI Input Current	I_{LBI}	$V_{LBI} = +0.8V$		9	100	nA
LBO Low Output Voltage		$V_{BATT} = V_{LBI} = +0.975V$, sinking $20\mu A$ (50Ω typ)			0.1	V
		$V_{BATT} = V_{LBI} = +1.1V$, sinking $100\mu A$ (25Ω typ)			0.1	
LBO Off-Leakage Current		$V_{LBO} = +5.5V$		1	100	nA
SHDN Input Voltage	V_{IL}				$0.2 \times V_{BATT}$	V
	V_{IH}		$0.8 \times V_{BATT}$			
Shutdown Input Current		$V_{SHDN} = 0$ and $+5.5V$			100	nA

ELECTRICAL CHARACTERISTICS

($V_{BATT} = +2V$, $OUT = FB$ ($V_{OUT} = +3.3V$), $SHDN = LBI = GND$, $T_A = -40^{\circ}C$ to $+85^{\circ}C$, unless otherwise noted.) (Note 3)

PARAMETER	SYMBOL	CONDITIONS	MIN	MAX	UNITS
Operating Voltage	V_{BATT}	Note 1	1.0	5.5	V
Output Voltage	V_{OUT}	FB = OUT	3.13	3.47	V
		FB = GND	4.75	5.25	
Adjustable Output Voltage Range			2.0	5.5	V
Steady-State Output Current (Note 1)	I_{OUT}	FB = OUT ($V_{OUT} = +3.3V$)	MAX1795	100	mA
			MAX1796	200	
			MAX1797	400	
		FB = GND ($V_{OUT} = +5.0V$)	MAX1795	60	
			MAX1796	125	
			MAX1797	250	
Feedback Set-Point Voltage (Adjustable Mode)	V_{FB}	$V_{OUT} = +2V$ to $+5.5V$	1.19	1.29	V
Feedback Input Current	I_{FB}	$V_{FB} = +1.25V$		100	nA

Low Supply Current, Step-Up DC-DC Converters with True-Shutdown

ELECTRICAL CHARACTERISTICS (continued)

($V_{BATT} = +2V$, $OUT = FB$ ($V_{OUT} = +3.3V$), $SHDN = LBI = GND$, $T_A = -40^{\circ}C$ to $+85^{\circ}C$, unless otherwise noted.) (Note 3)

PARAMETER	SYMBOL	CONDITIONS	MIN	MAX	UNITS
Internal NFET, PFET On-Resistance	$R_{DS(ON)}$	$V_{OUT} = +3.3V$, $I_{LX} = 100mA$	NFET	0.3	Ω
			PFET	0.45	
LX Switch Current Limit (NFET only)	I_{LIM}	MAX1795	0.19	0.37	A
		MAX1796	0.35	0.7	
		MAX1797	0.8	1.32	
LX Leakage Current	I_{LEAK}	$V_{LX} = 0$ and $+5.5V$, $V_{OUT} = +5.5V$			μA
Damping Switch On-Resistance	R_{DAMP}		100	400	Ω
Operating Current into OUT (Note 2)		$V_{FB} = +1.4V$		45	μA
Operating Current into BATT		$V_{FB} = +1.4V$, $V_{LBI} = +1V$		4	μA
Shutdown Current into BATT		$SHDN = BATT$, $V_{LBI} = +1V$		4	μA
LX Switch Maximum On-Time	t_{ON}	$V_{FB} = +1V$, if current limit not reached	2.75	5.25	μs
LX Switch Minimum Off-Time	t_{OFF}	$V_{FB} = +1V$	0.7	1.3	μs
LBI Threshold Voltage	V_{LBI}	$V_{BATT} = +2V$	0.8	0.90	V
		$V_{BATT} = LBI$	0.875	0.975	
LBI Input Current	I_{LBI}	$V_{LBI} = +0.8V$		100	nA
LBO Low Output Voltage		$V_{BATT} = V_{LBI} = +0.975V$, sinking $20\mu A$ (50Ω typ)		0.1	V
		$V_{BATT} = V_{LBI} = +1.1V$, sinking $100\mu A$ (25Ω typ)		0.1	
LBO Off-Leakage Current		$V_{LBO} = +5.5V$		100	nA
SHDN Input Voltage	V_{IL}			$0.2 \times V_{BATT}$	V
	V_{IH}		$0.8 \times V_{BATT}$		
Shutdown Input Current		$V_{SHDN} = 0$ and $+5.5V$		100	nA

Note 1: Operating Voltage: Since the regulator is bootstrapped to the output, once started it will operate down to a 0.7V input.

Note 2: Device is bootstrapped (power to IC comes from OUT). This correlates directly with the actual battery supply current.

Note 3: Specifications to $-40^{\circ}C$ are guaranteed by design, not production tested.

Low Supply Current, Step-Up DC-DC Converters with True-Shutdown

Typical Operating Characteristics

($L = 22\mu\text{H}$, $C_{\text{IN}} = 47\mu\text{F}$, $C_{\text{OUT}} = 47\mu\text{F}$, $T_{\text{A}} = +25^{\circ}\text{C}$, unless otherwise noted.)

MAX1795/MAX1796/MAX1797

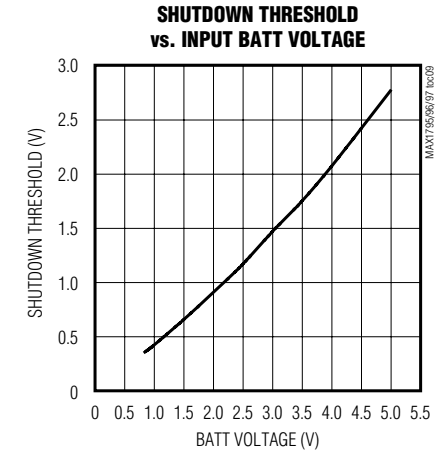
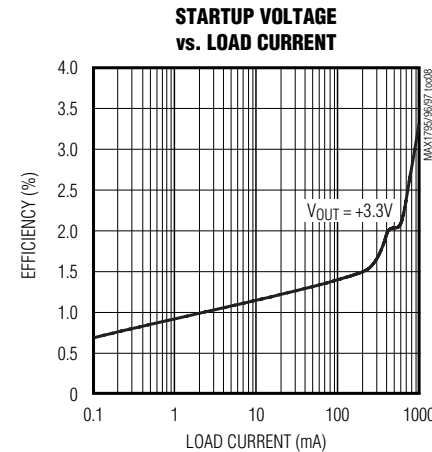
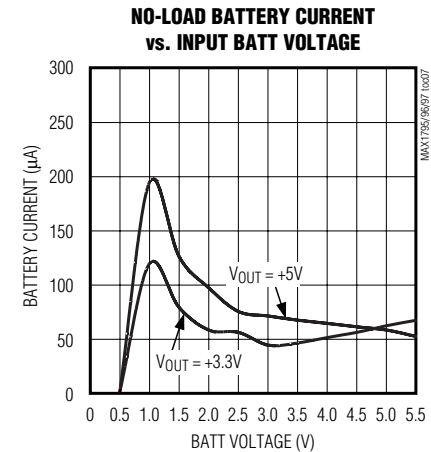
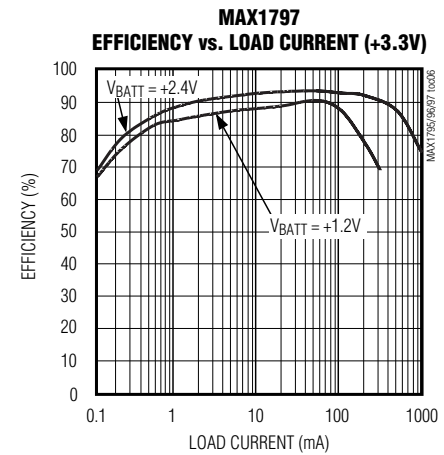
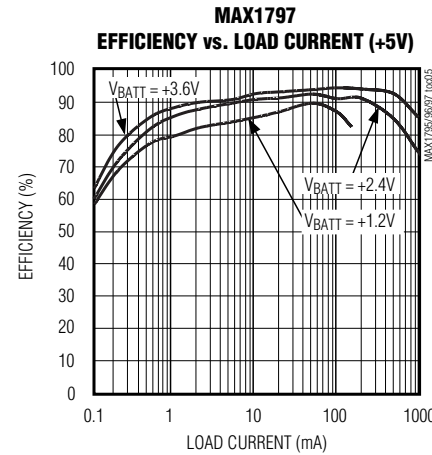
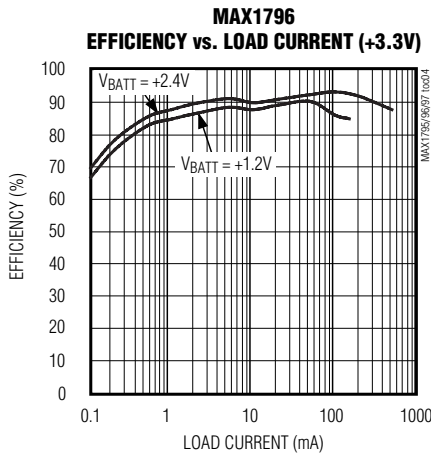
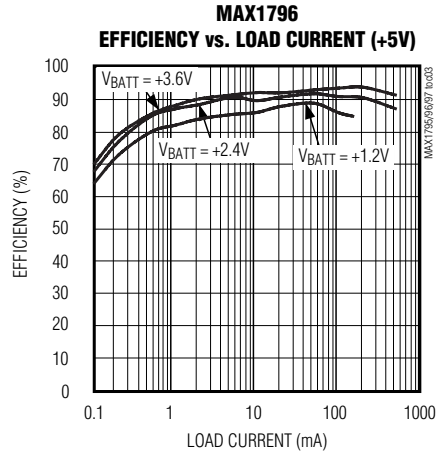
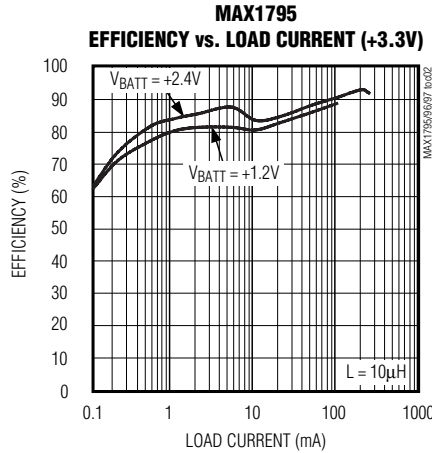
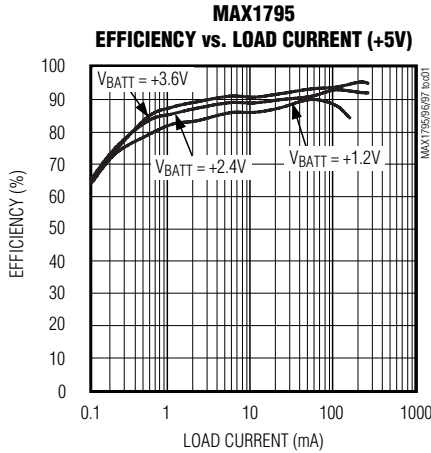

Low Supply Current, Step-Up DC-DC Converters with True-Shutdown

Typical Operating Characteristics (continued)

(L = 22μH, C_{IN} = 47μF, C_{OUT} = 47μF, T_A = +25°C, unless otherwise noted.)

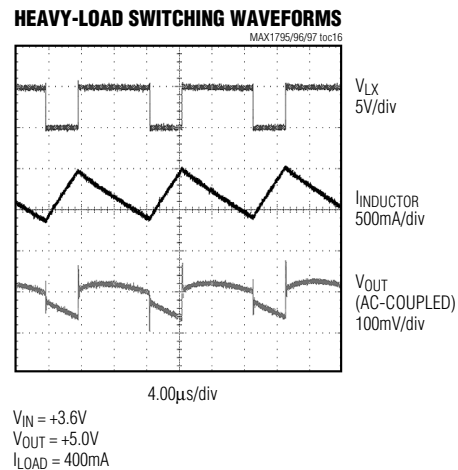
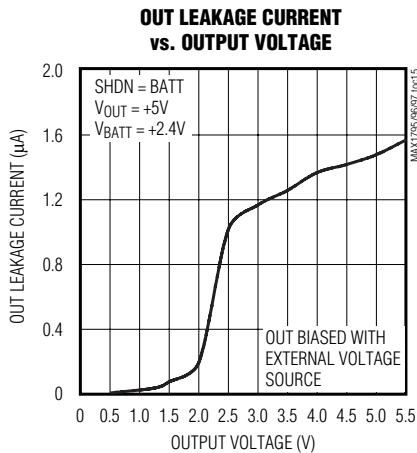
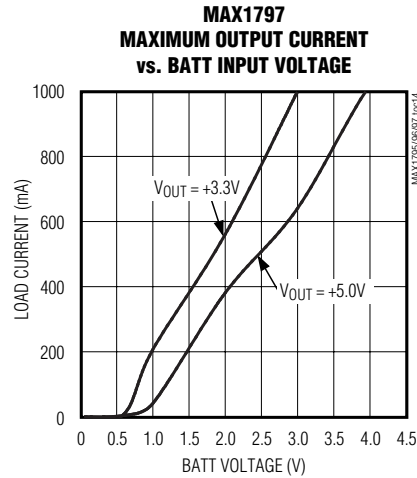
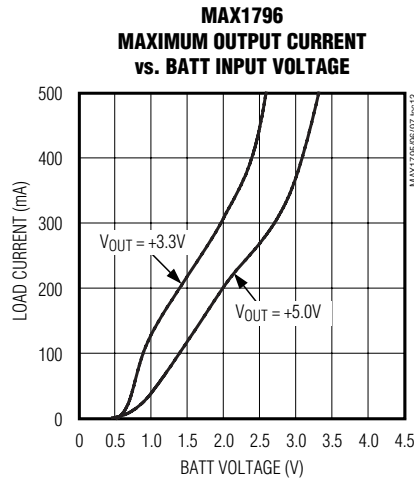
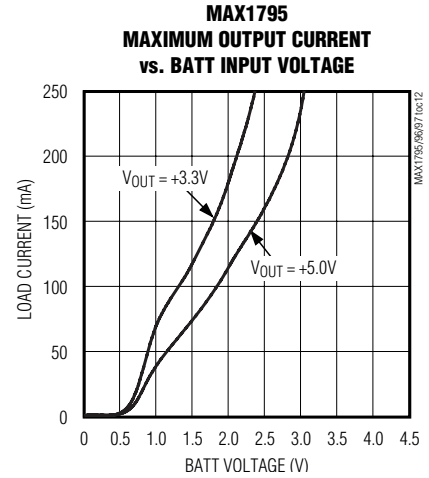
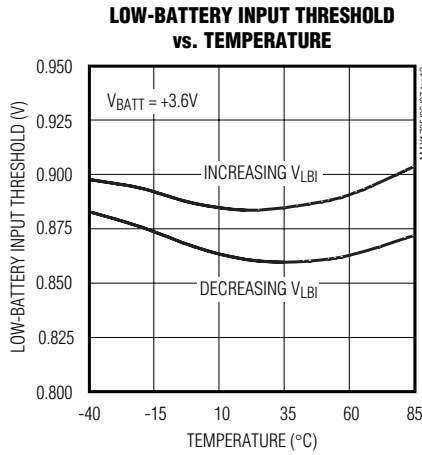
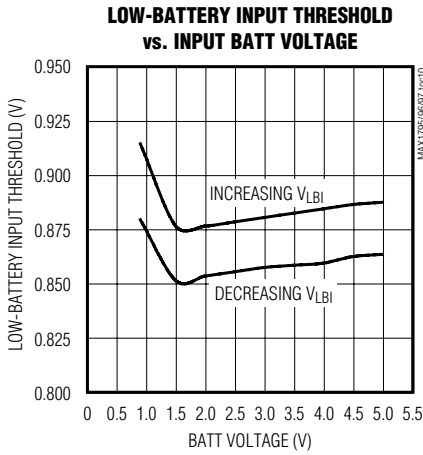

Low Supply Current, Step-Up DC-DC Converters with True-Shutdown

Typical Operating Characteristics (continued)

(L = 22μH, C_{IN} = 47μF, C_{OUT} = 47μF, T_A = +25°C, unless otherwise noted.)

LIGHT-LOAD SWITCHING WAVEFORMS

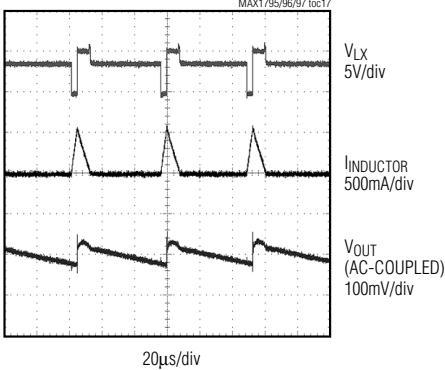

V_{BATT} = +3.6V
V_{OUT} = +5.0V
I_{LOAD} = 40mA

LINE-TRANSIENT RESPONSE

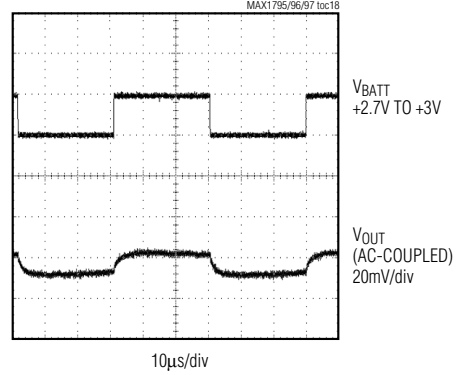

V_{BATT} = +2.7V TO +3V
V_{OUT} = +5.0V
NO LOAD

LOAD-TRANSIENT RESPONSE

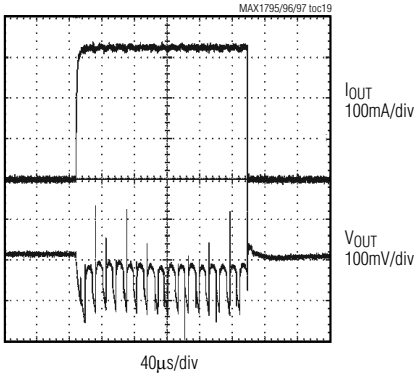

V_{BATT} = +2.4V
V_{OUT} = +3.3V
I_{LOAD} = 0 TO 325mA

STARTUP-SHUTDOWN WAVEFORMS

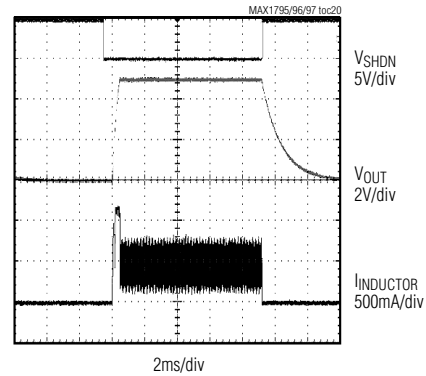

V_{BATT} = +2.4V
V_{OUT} = +5.0V
I_{LOAD} = 200mA

Low Supply Current, Step-Up DC-DC Converters with True-Shutdown

Pin Description

PIN	NAME	FUNCTION
1	LBI	Low-Battery Comparator Input. Internally set to trip at +0.85V. This function remains operational in shutdown.
2	FB	Dual-Mode™ Feedback Input. Connect to GND for preset 5.0V output. Connect to OUT for preset 3.3V output. Connect a resistive voltage-divider from OUT to GND to adjust the output voltage from 2V to 5.5V.
3	LBO	Low-Battery Comparator Output, Open-Drain Output. LBO is high impedance when $V_{LBI} < 0.85V$. This function remains operational in shutdown.
4	SHDN	Shutdown Input. If SHDN is high, the device is in shutdown mode, OUT is high impedance, and LBI/LBO are still operational. Connect shutdown to GND for normal operation.
5	GND	Ground
6	LX	Inductor Connection
7	OUT	Power Output. OUT provides bootstrap power to the IC.
8	BATT	Battery Input and Damping Switch Connection

Detailed Description

The MAX1795/MAX1796/MAX1797 compact step-up DC-DC converters start up with voltages as low as 0.85V and operate with an input voltage down to +0.7V. Consuming only 25 μ A of quiescent current, these devices have an internal synchronous rectifier that reduces cost by eliminating the need for an external diode and improves overall efficiency by minimizing losses in the circuit (see *Synchronous Rectification* section for details). The internal N-channel MOSFET power switch resistance is typically 0.17 Ω , which minimizes losses. The LX switch current limits of the MAX1795/MAX1796/MAX1797 are 0.25A, 0.5A, and 1A, respectively.

All three devices offer Maxim's proprietary True-Shutdown circuitry, which disconnects the output from the input in shutdown and puts the output in a high impedance state. These devices also feature Maxim's proprietary LX-damping circuitry, which reduces EMI in noise-sensitive applications. For additional in-system flexibility, the LBI/LBO comparator remains active in shutdown. (Figure 1 is a typical application circuit).

Control Scheme

A unique minimum-off-time, current-limited control scheme is the key to the MAX1795/MAX1796/MAX1797s' low operating current and high efficiency over a wide load range. The architecture combines the high output power and efficiency of a pulse-width-modulation (PWM) device with the ultra-low quiescent cur-

Dual Mode is a trademark of Maxim Integrated Products.

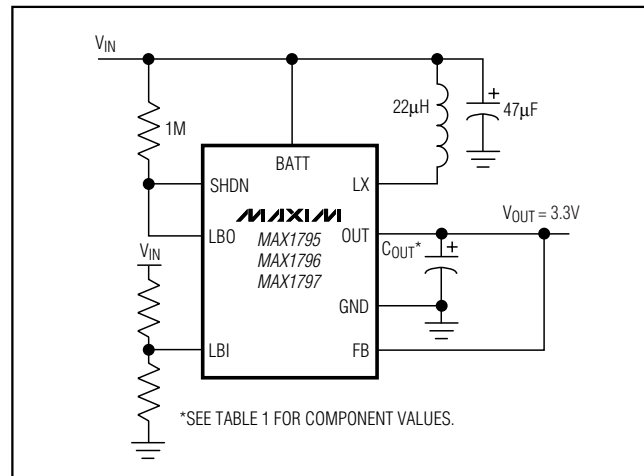

Figure 1. Typical Application Circuit

rent of a traditional pulse-skipping controller (Figure 2). Switching frequency depends upon the load current and input voltage, and can range up to 500kHz. Unlike conventional pulse-skipping DC-DC converters (where ripple amplitude varies with input voltage), ripple in these devices does not exceed the product of the switch current limit and the filter-capacitor equivalent series resistance (ESR).

Low Supply Current, Step-Up DC-DC Converters with True-Shutdown

MAX1795/MAX1796/MAX1797

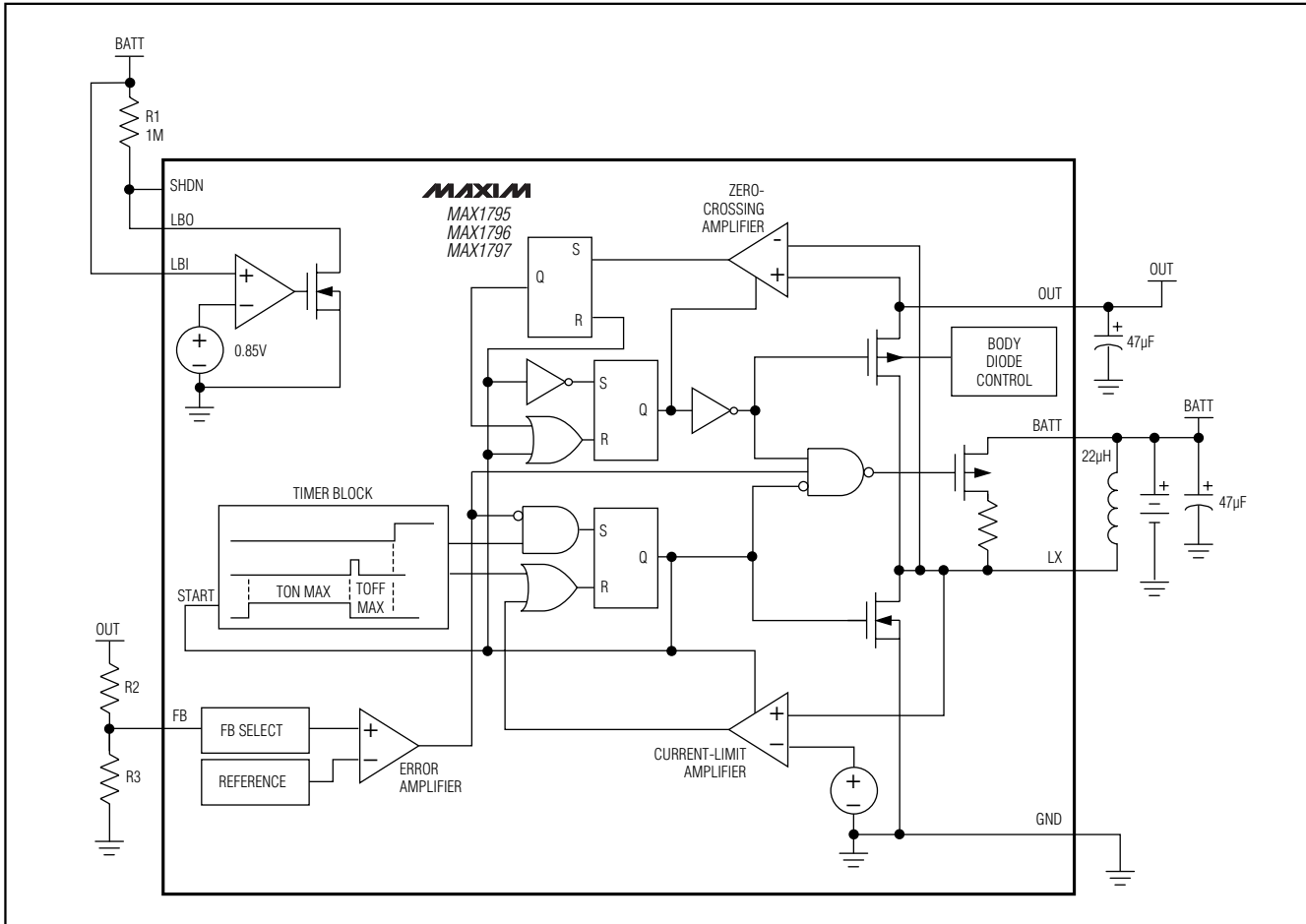

Figure 2. Functional Diagram

Synchronous Rectification

The internal synchronous rectifier eliminates the need for an external Schottky diode, reducing cost and board space. During the cycle off-time, the P-channel MOSFET turns on and shunts the MOSFET body diode. As a result, the synchronous rectifier significantly improves efficiency without the addition of an external component. Conversion efficiency can be as high as 95%, as shown in the *Typical Operating Characteristics*.

Shutdown

The device enters shutdown when V_{SHDN} is high, reducing supply current to less than $2\mu\text{A}$. During shutdown, the synchronous rectifier disconnects the output from the input, eliminating the DC conduction path that normally exists with traditional boost converters in shutdown mode. In shutdown, OUT becomes a high-imped-

ance node. The LBI/LBO comparator remains active in shutdown.

As shown in Figure 1, the MAX1795/MAX1796/MAX1797 may be automatically shut down when the input voltage drops below a preset threshold by connecting LBO to SHDN (see *Low-Battery Detection* section).

BATT/Damping Switch

The MAX1795/MAX1796/MAX1797 each contain an internal damping switch to minimize ringing at LX. The damping switch connects a resistor across the inductor when the inductor's energy is depleted (Figure 3). Normally, when the energy in the inductor is insufficient to supply current to the output, the capacitance and inductance at LX form a resonant circuit that causes ringing. The ringing continues until the energy is dissipated through the series resistance of the inductor. The damping switch supplies a path to quickly dissi-

Low Supply Current, Step-Up DC-DC Converters with True-Shutdown

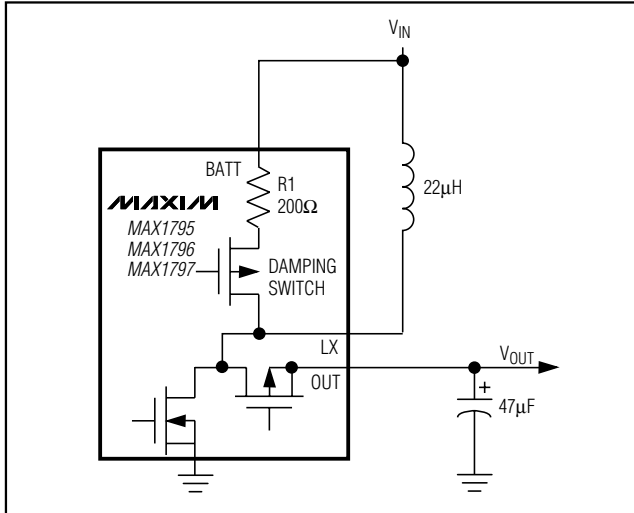

Figure 3. Simplified Diagram of Inductor Damping Switch

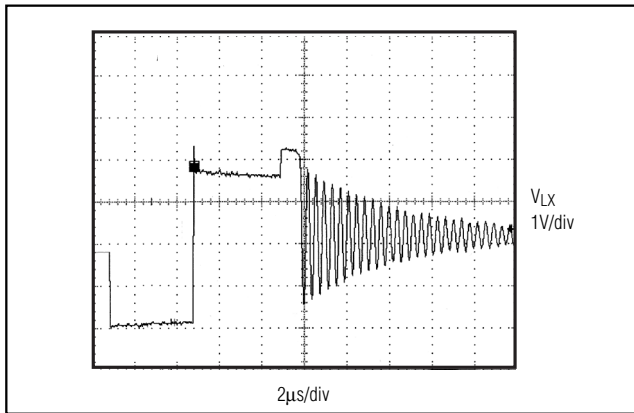

Figure 4. LX Ringing for Conventional Step-Up Converter (without Damping Switch)

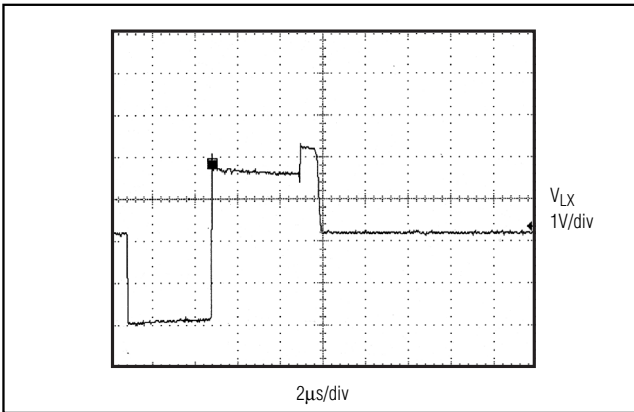

Figure 5. LX Waveform with Damping Switch

pate this energy, minimizing the ringing at LX. Damping LX ringing does not reduce \$V_{OUT}\$ ripple, but does reduce EMI (Figures 3, 4, and 5).

Setting the Output Voltage

\$V_{OUT}\$ can be set to 3.3V or 5.0V by connecting the FB pin to GND (5V) or OUT (3.3V). To adjust the output voltage, connect a resistive voltage-divider from OUT to FB to GND (Figure 6). Choose a value less than 250kΩ for R2.

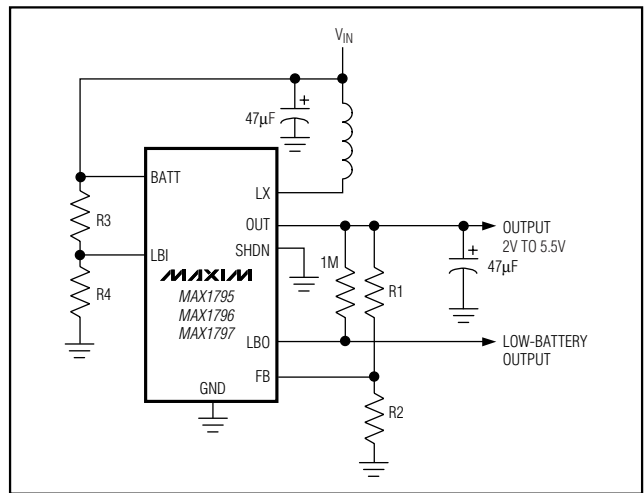

Figure 6. Setting an Adjustable Output

Use the following equation to calculate R1:

$$R1 = R2 [(V_{OUT} / V_{FB}) - 1]$$

where \$V_{FB} = +1.245V\$, and \$V_{OUT}\$ may range from +2V to +5.5V.

Low-Battery Detection

The MAX1795/MAX1796/MAX1797 each contain an on-chip comparator for low-battery detection. If the voltage at LBI is above 0.85V, LBO (an open-drain output) sinks current to GND. If the voltage at LBI is below 0.85V, LBO goes high impedance. The LBI/LBO function remains active even when the part is in shutdown.

Connect a resistive voltage-divider to LBI from BATT to GND. The low-battery monitor threshold is set by two resistors, R3 and R4 (Figure 6). Since the LBI bias current is typically 2nA, large resistor values (R4 up to 250kΩ) can be used to minimize loading of the input supply.

Calculate R3 using the following equation:

$$R3 = R4[(V_{TRIP} / 0.85V) - 1]$$

Low Supply Current, Step-Up DC-DC Converters with True-Shutdown

V_{TRIP} is the input voltage where the low-battery detector output goes high impedance.

For single-cell applications, LBI may be connected to the battery. When $V_{BATT} < 1.0V$, the LBI threshold increases to 0.925V (see *Typical Operating Characteristics*).

Connect a pullup resistor of 100k Ω or greater from LBO to OUT for a logic output. LBO is an open-drain output and can be pulled as high as 6V regardless of the voltage at OUT. When LBI is below the threshold, the LBO output is high impedance. If the low-battery comparator is not used, ground LBI and LBO.

Applications Information

Inductor Selection

An inductor value of 22 μ H performs well in most applications. The MAX1795/MAX1796/MAX1797 will also work with inductors in the 10 μ H to 47 μ H range. Smaller inductance values typically offer a smaller physical size for a given series resistance, allowing the smallest overall circuit dimensions, but have lower output current capability. Circuits using larger inductance values exhibit higher output current capability, but are physically larger for the same series resistance and current rating.

The inductor's incremental saturation current rating should be greater than the peak switch-current limit, which is 0.25A for the MAX1795, 0.5A for the MAX1796, and 1A for the MAX1797. However, it is generally acceptable to bias the inductor into saturation by as much as 20% although this will slightly reduce efficiency. Table 1 lists some suggested components for typical applications.

The inductor's DC resistance significantly affects efficiency. Calculate the maximum output current ($I_{OUT(MAX)}$) as follows, using inductor ripple current (I_{RIP}) and duty cycle (D):

$$I_{RIP} = \frac{V_{OUT} + I_{LIM} \times (R_{PFET} + L_{ESR}) - V_{BATT}}{\left[\frac{L}{t_{OFF}} + \frac{(R_{PFET} + L_{ESR})}{2} \right]}$$

$$D = \frac{V_{OUT} + \left(I_{LIM} - \frac{I_{RIP}}{2} \right) (R_{PFET} + L_{ESR}) - V_{BATT}}{V_{OUT} + \left(I_{LIM} - \frac{I_{RIP}}{2} \right) (R_{PFET} + R_{NFET} + L_{ESR})}$$

and

$$I_{OUT(MAX)} = \left(I_{LIM} - \frac{I_{RIP}}{2} \right) (1-D)$$

where: I_{RIP} = Inductor ripple current (A)

V_{OUT} = Output voltage (V)

I_{LIM} = Device current limit (0.25A, 0.5A, or 1A)

R_{PFET} = On-resistance of P-channel MOSFET (Ω) (typ 0.27 Ω)

L_{ESR} = ESR of Inductor (Ω) (typ 0.095 Ω)

V_{BATT} = Input voltage (V)

L = Inductor value in μ H

t_{OFF} = LX switch's off-time (μ s) (typ 1 μ s)

D = Duty cycle

R_{NFET} = On-resistance of N-channel MOSFET (Ω) (typ 0.17 Ω)

$I_{OUT(MAX)}$ = Maximum output current (A)

Capacitor Selection

Table 1 lists suggested tantalum or polymer capacitor values for typical applications. The ESR of both input bypass and output filter capacitors affects efficiency and output ripple. Output voltage ripple is the product of the peak inductor current and the output capacitor ESR. High-frequency output noise can be reduced by connecting a 0.1 μ F ceramic capacitor in parallel with the output filter capacitor. (See Table 2 for a list of suggested component suppliers.)

PC Board Layout and Grounding

Careful printed circuit layout is important for minimizing ground bounce and noise. Keep the IC's GND pin and the ground leads of the input and output filter capacitors less than 0.2in (5mm) apart. In addition, keep all connections to the FB and LX pins as short as possible. In particular, when using external feedback resistors, locate them as close to FB as possible. To maximize output power and efficiency and minimize output ripple voltage, use a ground plane and solder the IC's GND pin directly to the ground plane.

Low Supply Current, Step-Up DC-DC Converters with True-Shutdown

Table 1. Suggested Components for Typical Applications

COMPONENT	COMPONENT VALUE (MAX1797, 1A CURRENT LIMIT)	COMPONENT VALUE (MAX1796, 0.5A CURRENT LIMIT)	COMPONENT VALUE (MAX1795, 0.25A CURRENT LIMIT)
Inductor	Sumida CDRH6D28-220, 22 μ H	Sumida CDRH4D28-220, 22 μ H	Sumida CR32-220, 22 μ H
			Sumida CR32-100, 10 μ H
			Murata CQH3C100K34, 10 μ H
	Coilcraft DS3316P-223, 22 μ H	Coilcraft DS1608C-223, 22 μ H	Murata CQH4N100K(J)04, 10 μ H
			Coilcraft DS1608C-223, 22 μ H
Coilcraft DS1608C-103, 10 μ H			
Input Capacitor	Sanyo POSCAP 6TPA47M, 47 μ F	Sanyo POSCAP 6TPA47M, 47 μ F	Sanyo POSCAP 6TPA47M, 47 μ F
Output Capacitor	AVX TPSD476M016R0150, 47 μ F	AVX TPSD226M016R0150, 22 μ F	AVX TPSD106M016R0150, 10 μ F
	Taiyo Yuden UMK316BI150KH, 0.1 μ F	Taiyo Yuden UMK316BI150KH, 0.1 μ F	Taiyo Yuden UMK316BI150KH, 0.1 μ F

Table 2. Component Suppliers

COMPANY	PHONE	FAX
AVX	USA 803-946-0690	USA 803-626-3123
Coilcraft	USA 847-639-6400	USA 847-639-1238-469
Coiltronics	USA 561-241-7876	USA 561-241-9339
Murata	USA 814-237-1431 1-800-831-9172	USA 814-238-0490
Nihon	USA 805-867-2555 Japan 81-3-3494-7411	USA 805-867-2556 Japan 81-3-3494-7414
Sanyo	USA 619-661-6835 Japan 81-7-2070-6306	USA 619-661-1055 Japan 81-7-2070-1174
Sprague	USA 603-224-1961	USA 603-224-1430
Sumida	USA 647-956-0666 Japan 81-3-3607-5111	USA 647-956-0702 Japan 81-3-3607-5144
Taiyo Yuden	USA 408-573-4150	USA 408-573-4159

Chip Information

TRANSISTOR COUNT: 1100

PROCESS: BiCMOS

Low Supply Current, Step-Up DC-DC Converters with True-Shutdown

Package Information

MAX1795/MAX1796/MAX1797

	INCHES		MILLIMETERS		JEDEC			
	MIN	MAX	MIN	MAX	MIN	MAX	MIN	MAX
A	0.037	0.043	0.94	1.10	---	0.043	---	1.10
A1	0.002	0.006	0.05	0.15	0.002	0.006	0.05	0.15
B	0.010	0.014	0.25	0.36	0.010	0.016	0.25	0.40
C	0.005	0.007	0.13	0.18	0.005	0.009	0.13	0.23
D	0.116	0.120	2.95	3.05	0.114	0.122	2.9	3.1
e	0.0256 BSC		0.65 BSC		0.0256 BSC		0.64 BSC	
E	0.116	0.120	2.95	3.05	0.114	0.122	2.9	3.1
H	0.188	0.198	4.78	5.03	0.193 BSC		4.9 BSC	
L	0.016	0.026	0.41	0.66	0.016	0.027	0.40	0.70
α	0°	6°	0°	6°	0°	6°	0°	6°
S	0.0207 BSC		0.5250 BSC					

NOTES:
 1. D&E DO NOT INCLUDE MOLD FLASH.
 2. MOLD FLASH OR PROTRUSIONS NOT TO EXCEED 0.15MM (.006").
 3. CONTROLLING DIMENSION: MILLIMETERS.
 4. MEETS JEDEC MO-187.

MAXIM			
PROPRIETARY INFORMATION			
TITLE: PACKAGE OUTLINE, 8L μ MAX			
APPROVAL	DOCUMENT CONTROL NO. 21-0036	REV I	1/1

8LUMAXD.EPS

Maxim cannot assume responsibility for use of any circuitry other than circuitry entirely embodied in a Maxim product. No circuit patent licenses are implied. Maxim reserves the right to change the circuitry and specifications without notice at any time.

Maxim Integrated Products, 120 San Gabriel Drive, Sunnyvale, CA 94086 408-737-7600 13