

VOLTAGE CONVERTER

■ GENERAL DESCRIPTION

The NJU7662 is a voltage converter incorporated CR-oscillator, voltage-level-shifter and power-MOS, which generates a polarity-converted negative voltage or two-fold voltage of an operating voltage ranging from +4.5 to +20.0V.

The application circuit of negative voltage converter requires only two capacitors, and positive twofold voltage converter requires two capacitors, two resistors and one diode as external components.

The oscillation frequency of the internal oscillator is 10kHz and the negative voltage converter (on no-load condition) achieves extremely high-efficiency voltage conversion rate of 99.9%.

■ FEATURES

- Polarity-converted Negative Voltage Output
- Twofold Positive Voltage Output
- Operating Voltage --- +4.5 to +20.0 V
- High-efficiency Voltage Conversion Rate -- 99.9%
(No-load, Negative Voltage Converter)
- High-efficiency Power Conversion Rate -- 96%
(Negative Voltage Converter)
- Cascade Connection Available
2N-1 times voltage outputs for negative voltage
2N times voltage outputs for positive voltage
- Few External Components
--- 2 Capacitors (Negative Voltage Converter)
--- 2 Capacitors, 2 Resistors and 1 Diode
(Positive Voltage Converter)
- Package Outline DIP/DMP 8
- C-MOS Technology

■ BLOCK DIAGRAM

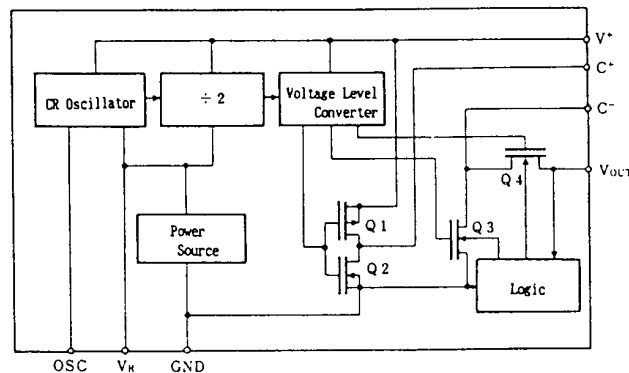

■ PACKAGE OUTLINE

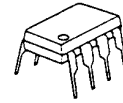

NJU7662D



NJU7662M

■ PIN CONFIGURATION

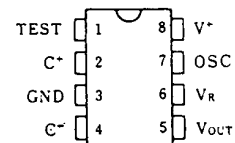

■ APPLICATION CIRCUITS

(1-1) NEGATIVE VOLTAGE OUTPUT

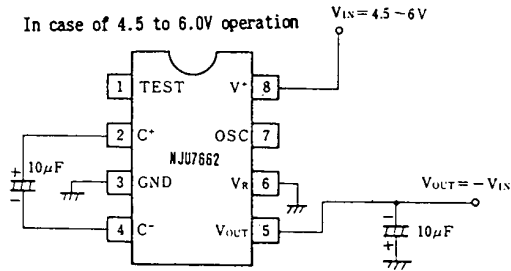

(1-2) NEGATIVE VOLTAGE OUTPUT

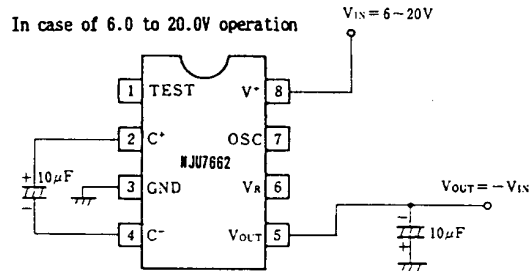

(*1) No. 6 Terminal must connect to GND or Open according to the operating voltage as follows;
 $V_+ < 6V$ --- Connect to GND
 $V_+ \geq 6V$ --- OPEN

(2) TWOFOLD VOLTAGE OUTPUT

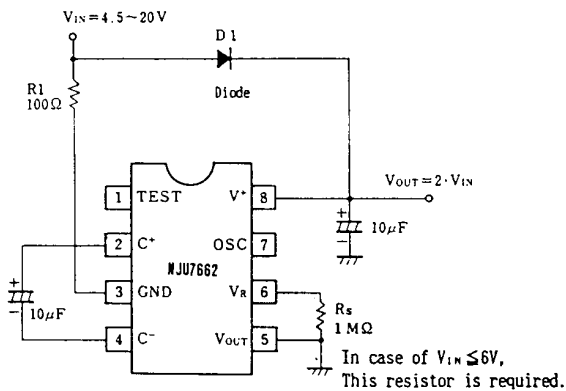

In the twofold voltage application, R_1 , R_s and D_1 are required for start-up.

■ ABSOLUTE MAXIMUM RATINGS

(Ta=25°C)

PARAMETER	SYMBOL	RATINGS	UNIT
Supply Voltage	V*	22	V
Input Voltage	V _{IN}	-0.3~V*+0.3 @V* < 7 V*-7~V*+0.3 @V* > 7	V
Output Short		CONTINUITY @V* < 5.5	V
Power Dissipation	P _D	500 (DIP) 300 (DMP)	mW
Operating Temperature Range	Topr	-20 ~ + 70	°C
Storage Temperature Range	Tstg	-65 ~ +150	°C

■ ELECTRICAL CHARACTERISTICS

 (Ta=25°C, V*=15V, C_{osc}=0)

PARAMETER	SYMBOL	CONDITIONS	MIN	TYP	MAX	UNIT
Operating Current	I*1	R _L =∞, V _R =OPEN		250	600	μA
	I*2	V+=5V, R _L =∞, V _R =GND		20	150	
Operating Voltage	V*HI	-20°C ≤ Ta ≤ 70°C, V _R =OPEN	3.0		10.0	V
	V*LO	R _L =10kΩ, V _R =GND	4.5		6	
Output Resistance (*Note 1)	R _{o1}	I _{out} =20mA, Ta=25°C		60	100	Ω
		V _R =OPEN, -20°C ≤ Ta ≤ 70°C		70	120	
	R _{o2}	V+=5V, I _{out} =3mA, Ta=25°C		125	200	
		V _R =GND, -20°C ≤ Ta ≤ 70°C		150	250	
Oscillation Frequency	F _o			10		kHz
Power Conversion Rate	P _{EF}	R _L =2kΩ	93	96		%
Voltage Conversion Rate	V _{EF}	R _L =∞	97	99.9		%
Oscillation Terminal Input Current	I _{osc1}	V*=15V, (V _{osc} =8~15V)		4.0		μA
	I _{osc2}	V+=5V, (V _{osc} =0~5)		0.5		

*Note 1 The twofold positive converter needs 100 ohms series resistance on the power source terminal, therefore the output impedance increases to 200 ohms.