

## FEATURES

- **5V at 1A from a Single Li-Ion Cell**
- **5V at 800mA in SEPIC Mode from Four NiCd Cells**
- **Fixed Frequency Operation: 600kHz**
- **Boost Converter Outputs up to 34V**
- Starts into Heavy Loads
- Automatic Burst Mode™ Operation at Light Load (LT1308A)
- Continuous Switching at Light Loads (LT1308B)
- Low  $V_{CESAT}$  Switch: 300mV at 2A
- Pin-for-Pin Upgrade Compatible with LT1308
- Lower Quiescent Current in Shutdown: 1 $\mu$ A (Max)
- Improved Accuracy Low-Battery Detector Reference: 200mV  $\pm$  2%
- Available in 8-Lead SO and 14-Lead TSSOP Packages

## APPLICATIONS

- GSM/CDMA Phones
- Digital Cameras
- LCD Bias Supplies
- Answer-Back Pagers
- GPS Receivers
- Battery Backup Supplies
- Handheld Computers

## DESCRIPTION

The LT<sup>®</sup>1308A/LT1308B are micropower, fixed frequency step-up DC/DC converters that operate over a 1V to 10V input voltage range. They are improved versions of the LT1308 and are recommended for use in new designs. The LT1308A features automatic shifting to power saving Burst Mode operation at light loads and consumes just 140 $\mu$ A at no load. The LT1308B features continuous switching at light loads and operates at a quiescent current of 2.5mA. Both devices consume less than 1 $\mu$ A in shutdown.

Low-battery detector accuracy is significantly tighter than the LT1308. The 200mV reference is specified at  $\pm$  2% at room and  $\pm$  3% over temperature. The shutdown pin enables the device when it is tied to a 1V or higher source and does not need to be tied to  $V_{IN}$  as on the LT1308. An internal  $V_C$  clamp results in improved transient response and the switch voltage rating has been increased to 36V, enabling higher output voltage applications.

The LT1308A/LT1308B are available in the 8-lead SO and the 14-lead TSSOP packages.

LT, LT, LTC, LTM, Burst Mode, Linear Technology and the Linear logo are registered trademarks of Linear Technology Corporation. All other trademarks are the property of their respective owners.

## TYPICAL APPLICATION

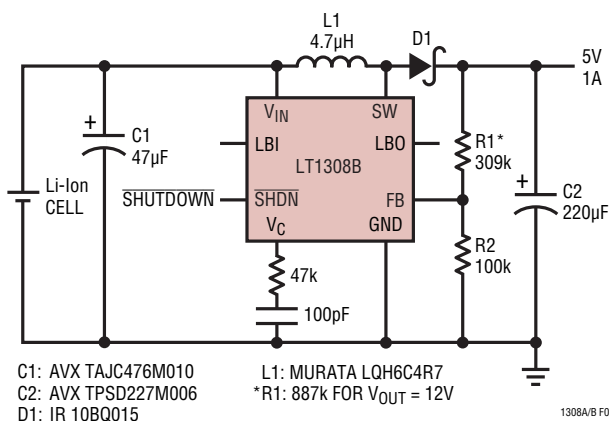
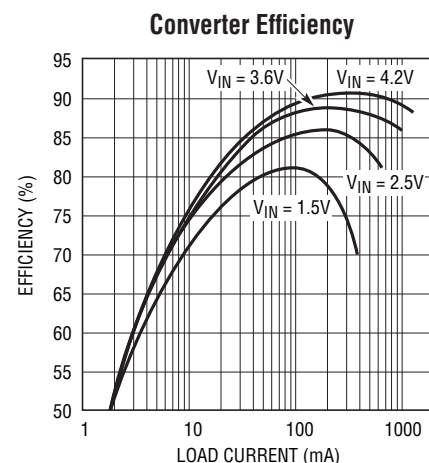


Figure 1. LT1308B Single Li-Ion Cell to 5V/1A DC/DC Converter



1308A/B F01a

1308abfb

# LT1308A/LT1308B

## ABSOLUTE MAXIMUM RATINGS (Note 1)

$V_{IN}$ , $\overline{SHDN}$ , LBO Voltage.....	10V	Operating Temperature Range	
SW Voltage .....	-0.4V to 36V	Commercial.....	0°C to 70°C
FB Voltage.....	$V_{IN} + 1V$	Extended Commercial (Note 2) .....	-40°C to 85°C
$V_C$ Voltage .....	2V	Industrial .....	-40°C to 85°C
LBI Voltage .....	-0.1V to 1V	Storage Temperature Range.....	-65°C to 150°C
Current into FB Pin.....	$\pm 1mA$	Lead Temperature (Soldering, 10 sec) .....	300°C

## PIN CONFIGURATION



## ORDER INFORMATION

LEAD FREE FINISH	TAPE AND REEL	PART MARKING	PACKAGE DESCRIPTION	TEMPERATURE RANGE
LT1308ACS8#PBF	LT1308ACS8#TRPBF	1308A	8-Lead Plastic SO	0°C to 70°C
LT1308AIS8#PBF	LT1308AIS8#TRPBF	1308AI	8-Lead Plastic SO	-40°C to 85°C
LT1308BCS8#PBF	LT1308BCS8#TRPBF	1308B	8-Lead Plastic SO	0°C to 70°C
LT1308BIS8#PBF	LT1308BIS8#TRPBF	1308BI	8-Lead Plastic SO	-40°C to 85°C
LT1308ACF#PBF	LT1308ACF#TRPBF	LT1308ACF	14-Lead Plastic TSSOP	0°C to 70°C
LT1308BCF#PBF	LT1308BCF#TRPBF	LT1308BCF	14-Lead Plastic TSSOP	0°C to 70°C
LEAD BASED FINISH	TAPE AND REEL	PART MARKING	PACKAGE DESCRIPTION	TEMPERATURE RANGE
LT1308ACS8	LT1308ACS8#TR	1308A	8-Lead Plastic SO	0°C to 70°C
LT1308AIS8	LT1308AIS8#TR	1308AI	8-Lead Plastic SO	-40°C to 85°C
LT1308BCS8	LT1308BCS8#TR	1308B	8-Lead Plastic SO	0°C to 70°C
LT1308BIS8	LT1308BIS8#TR	1308BI	8-Lead Plastic SO	-40°C to 85°C
LT1308ACF	LT1308ACF#TR	LT1308ACF	14-Lead Plastic TSSOP	0°C to 70°C
LT1308BCF	LT1308BCF#TR	LT1308BCF	14-Lead Plastic TSSOP	0°C to 70°C

Consult LTC Marketing for parts specified with wider operating temperature ranges.

For more information on lead free part marking, go to: <http://www.linear.com/leadfree/>

This product is only offered in trays. For more information go to: <http://www.linear.com/packaging/>

1308abfb

**ELECTRICAL CHARACTERISTICS** The ● denotes the specifications which apply over the full operating temperature range, otherwise specifications are at T<sub>A</sub> = 25°C. Commercial Grade 0°C to 70°C. V<sub>IN</sub> = 1.1V, V<sub>SHDN</sub> = V<sub>IN</sub>, unless otherwise noted.

SYMBOL	PARAMETER	CONDITIONS	MIN	TYP	MAX	UNITS	
I <sub>Q</sub>	Quiescent Current	Not Switching, LT1308A		140	240	μA	
		Switching, LT1308B		2.5	4	mA	
		V <sub>SHDN</sub> = 0V (LT1308A/LT1308B)		0.01	1	μA	
V <sub>FB</sub>	Feedback Voltage		●	1.20	1.22	1.24	V
I <sub>B</sub>	FB Pin Bias Current	(Note 3)	●		27	80	nA
	Reference Line Regulation	1.1V ≤ V <sub>IN</sub> ≤ 2V 2V ≤ V <sub>IN</sub> ≤ 10V	●		0.03 0.01	0.4 0.2	%/V %/V
	Minimum Input Voltage			0.92	1	V	
g <sub>m</sub>	Error Amp Transconductance	ΔI = 5μA		60		μmhos	
A <sub>V</sub>	Error Amp Voltage Gain			100		V/V	
f <sub>OSC</sub>	Switching Frequency	V <sub>IN</sub> = 1.2V	●	500	600	700	kHz
	Maximum Duty Cycle		●	82	90		%
	Switch Current Limit	Duty Cycle = 30% (Note 4)		2	3	4.5	A
	Switch V <sub>CESAT</sub>	I <sub>SW</sub> = 2A (25°C, 0°C), V <sub>IN</sub> = 1.5V		290	350	mV	
		I <sub>SW</sub> = 2A (70°C), V <sub>IN</sub> = 1.5V		330	400	mV	
	Burst Mode Operation Switch Current Limit (LT1308A)	V <sub>IN</sub> = 2.5V, Circuit of Figure 1		400		mA	
	Shutdown Pin Current	V <sub>SHDN</sub> = 1.1V	●	2	5	μA	
		V <sub>SHDN</sub> = 6V	●	20	35	μA	
		V <sub>SHDN</sub> = 0V	●	0.01	0.1	μA	
	LBI Threshold Voltage		●	196	200	204	mV
			●	194	200	206	mV
	LBO Output Low	I <sub>SINK</sub> = 50μA	●	0.1	0.25	V	
	LBO Leakage Current	V <sub>LBI</sub> = 250mV, V <sub>LBO</sub> = 5V	●	0.01	0.1	μA	
	LBI Input Bias Current (Note 5)	V <sub>LBI</sub> = 150mV		33	100	nA	
	Low-Battery Detector Gain			3000		V/V	
	Switch Leakage Current	V <sub>SW</sub> = 5V	●	0.01	10	μA	

The ● denotes the specifications which apply over the full operating temperature range, otherwise specifications are at T<sub>A</sub> = 25°C. Industrial Grade -40°C to 85°C. V<sub>IN</sub> = 1.2V, V<sub>SHDN</sub> = V<sub>IN</sub>, unless otherwise noted.

SYMBOL	PARAMETER	CONDITIONS	MIN	TYP	MAX	UNITS	
I <sub>Q</sub>	Quiescent Current	Not Switching, LT1308A	●		140	240	μA
		Switching, LT1308B	●		2.5	4	mA
		V <sub>SHDN</sub> = 0V (LT1308A/LT1308B)	●		0.01	1	μA
V <sub>FB</sub>	Feedback Voltage		●	1.19	1.22	1.25	V
I <sub>B</sub>	FB Pin Bias Current	(Note 3)	●		27	80	nA
	Reference Line Regulation	1.1V ≤ V <sub>IN</sub> ≤ 2V 2V ≤ V <sub>IN</sub> ≤ 10V	●		0.05 0.01	0.4 0.2	%/V %/V
	Minimum Input Voltage			0.92	1	V	
g <sub>m</sub>	Error Amp Transconductance	ΔI = 5μA		60		μmhos	
A <sub>V</sub>	Error Amp Voltage Gain			100		V/V	

# LT1308A/LT1308B

**ELECTRICAL CHARACTERISTICS** The ● denotes the specifications which apply over the full operating temperature range, otherwise specifications are at  $T_A = 25^\circ\text{C}$ . Industrial Grade  $-40^\circ\text{C}$  to  $85^\circ\text{C}$ .  $V_{IN} = 1.2\text{V}$ ,  $V_{SHDN} = V_{IN}$ , unless otherwise noted.

SYMBOL	PARAMETER	CONDITIONS	MIN	TYP	MAX	UNITS
$f_{OSC}$	Switching Frequency		● 500	600	750	kHz
	Maximum Duty Cycle		● 82	90		%
	Switch Current Limit	Duty Cycle = 30% (Note 4)	2	3	4.5	A
	Switch $V_{CESAT}$	$I_{SW} = 2\text{A}$ ( $25^\circ\text{C}$ , $-40^\circ\text{C}$ ), $V_{IN} = 1.5\text{V}$ $I_{SW} = 2\text{A}$ ( $85^\circ\text{C}$ ), $V_{IN} = 1.5\text{V}$		290 330	350 400	mV mV
	Burst Mode Operation Switch Current Limit (LT1308A)	$V_{IN} = 2.5\text{V}$ , Circuit of Figure 1		400		mA
	Shutdown Pin Current	$V_{SHDN} = 1.1\text{V}$ $V_{SHDN} = 6\text{V}$ $V_{SHDN} = 0\text{V}$	●	2	5	$\mu\text{A}$
●			20	35	$\mu\text{A}$	
●			0.01	0.1	$\mu\text{A}$	
	LBI Threshold Voltage		● 196 193	200 200	204 207	mV mV
	LBO Output Low	$I_{SINK} = 50\mu\text{A}$	●	0.1	0.25	V
	LBO Leakage Current	$V_{LBI} = 250\text{mV}$ , $V_{LBO} = 5\text{V}$	●	0.01	0.1	$\mu\text{A}$
	LBI Input Bias Current (Note 5)	$V_{LBI} = 150\text{mV}$		33	100	nA
	Low-Battery Detector Gain			3000		V/V
	Switch Leakage Current	$V_{SW} = 5\text{V}$	●	0.01	10	$\mu\text{A}$

**Note 1:** Stresses beyond those listed under Absolute Maximum Ratings may cause permanent damage to the device. Exposure to any Absolute Maximum Rating condition for extended periods may affect device reliability and lifetime.

**Note 2:** The LT1308ACS8, LT1308ACF, LT1308BCS8 and LT1308BCF are designed, characterized and expected to meet the industrial temperature limits, but are not tested at  $-40^\circ\text{C}$  and  $85^\circ\text{C}$ . I grade devices are guaranteed over the  $-40^\circ\text{C}$  to  $85^\circ\text{C}$  operating temperature range.

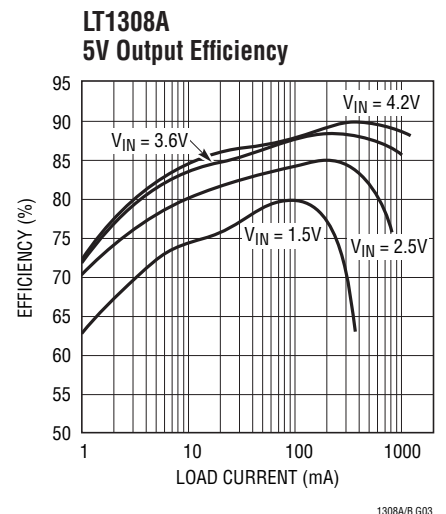
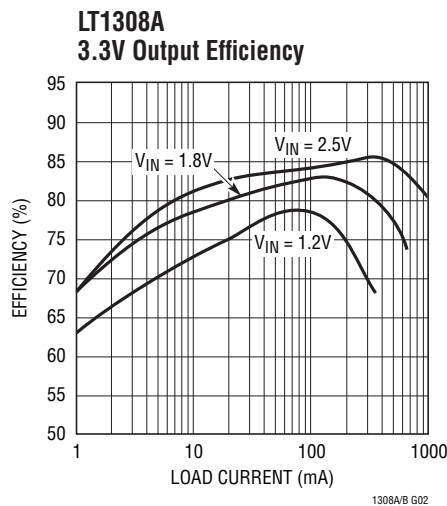
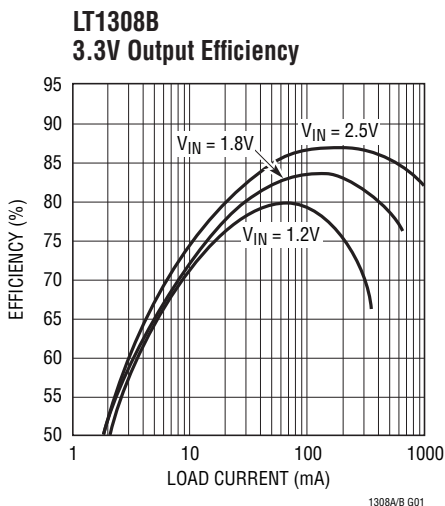
**Note 3:** Bias current flows into FB pin.

**Note 4:** Switch current limit guaranteed by design and/or correlation to static tests. Duty cycle affects current limit due to ramp generator (see Block Diagram).

**Note 5:** Bias current flows out of LBI pin.

**Note 6:** Connect the four GND pins (Pins 4–7) together at the device. Similarly, connect the three SW pins (Pins 8–10) together and the two  $V_{IN}$  pins (Pins 11, 12) together at the device.

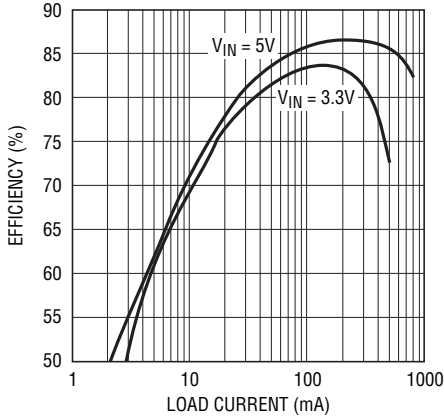
## TYPICAL PERFORMANCE CHARACTERISTICS



1308abfb

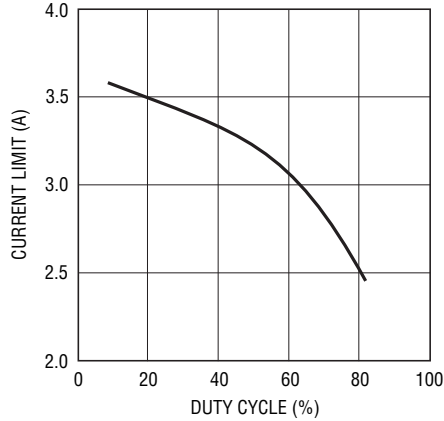
# TYPICAL PERFORMANCE CHARACTERISTICS

**LT1308B  
12V Output Efficiency**



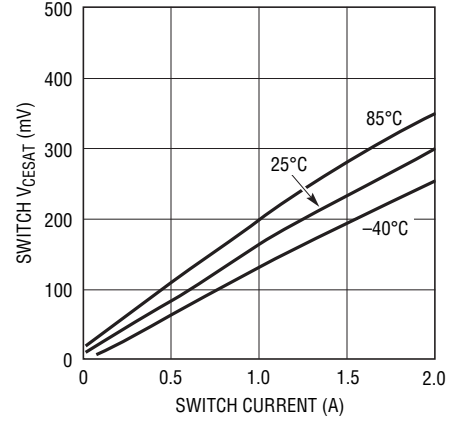
1308A/B G04

**Switch Current Limit vs  
Duty Cycle**



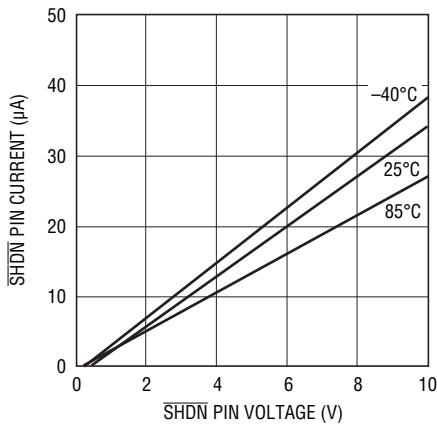
1308 • G05

**Switch Saturation Voltage  
vs Current**



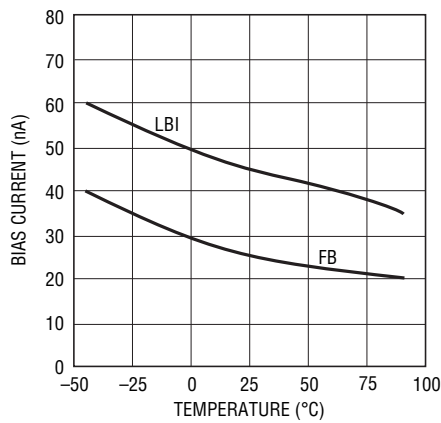
1308 G06

**SHDN Pin Bias Current vs Voltage**



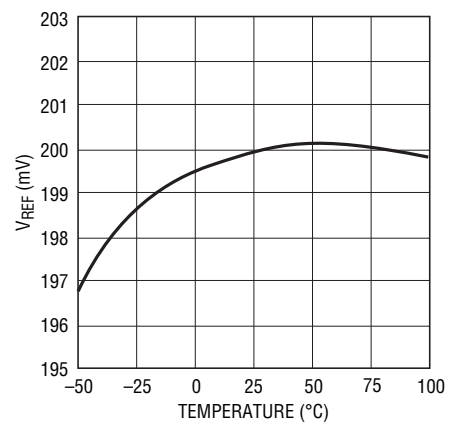
1308 G07

**FB, LBI Bias Current vs  
Temperature**



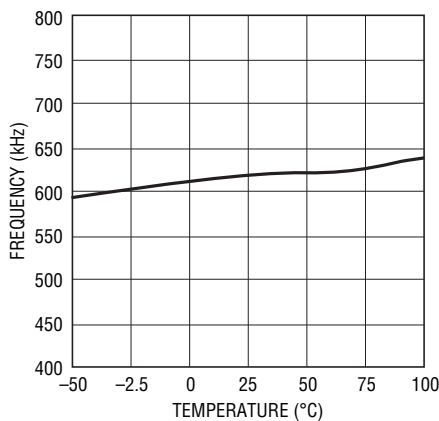
1308 • G08

**Low Battery Detector Reference  
vs Temperature**



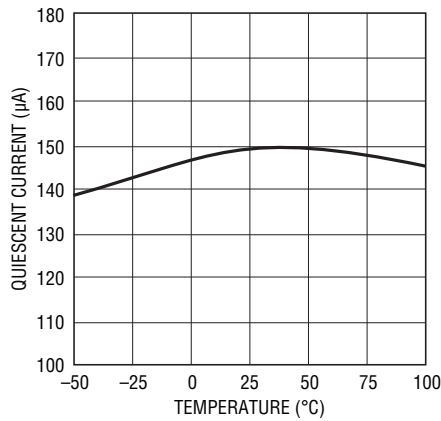
1308 • G09

**Oscillator Frequency vs  
Temperature**



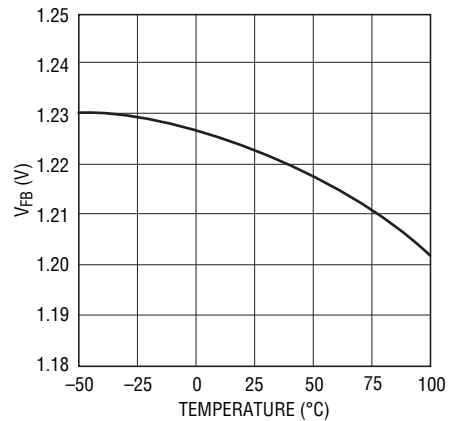
1308 • G10

**LT1308A Quiescent Current vs  
Temperature**



1308 • G11

**Feedback Pin Voltage vs  
Temperature**



1308 • G12

## PIN FUNCTIONS (SO/TSSOP)

**V<sub>C</sub> (Pin 1/Pin 1):** Compensation Pin for Error Amplifier. Connect a series RC from this pin to ground. Typical values are 47kΩ and 100pF. Minimize trace area at V<sub>C</sub>.

**FB (Pin 2/Pin 2):** Feedback Pin. Reference voltage is 1.22V. Connect resistive divider tap here. Minimize trace area at FB. Set V<sub>OUT</sub> according to:

$$V_{OUT} = 1.22V(1 + R1/R2).$$

**SHDN (Pin 3/Pin 3):** Shutdown. Ground this pin to turn off switcher. To enable, tie to 1V or more. SHDN does not need to be at V<sub>IN</sub> to enable the device.

**GND (Pin 4/Pins 4, 5, 6, 7):** Ground. Connect directly to local ground plane. Ground plane should enclose all components associated with the LT1308. PCB copper connected to these pins also functions as a heat sink. For the TSSOP package, connect all pins to ground copper to get the best heat transfer. This keeps chip heating to a minimum.

**SW (Pin 5/Pins 8, 9, 10):** Switch Pins. Connect inductor/diode here. Minimize trace area at these pins to keep EMI down. For the TSSOP package, connect all SW pins together at the package.

**V<sub>IN</sub> (Pin 6/Pins 11, 12):** Supply Pins. Must have local bypass capacitor right at the pins, connected directly to ground. For the TSSOP package, connect both V<sub>IN</sub> pins together at the package.

**LBI (Pin 7/Pin 13):** Low-Battery Detector Input. 200mV reference. Voltage on LBI must stay between -100mV and 1V. Low-battery detector does not function with SHDN pin grounded. Float LBI pin if not used.

**LBO (Pin 8/Pin 14):** Low-Battery Detector Output. Open collector, can sink 50μA. A 220kΩ pull-up is recommended. LBO is high impedance when SHDN is grounded.

**BLOCK DIAGRAMS**

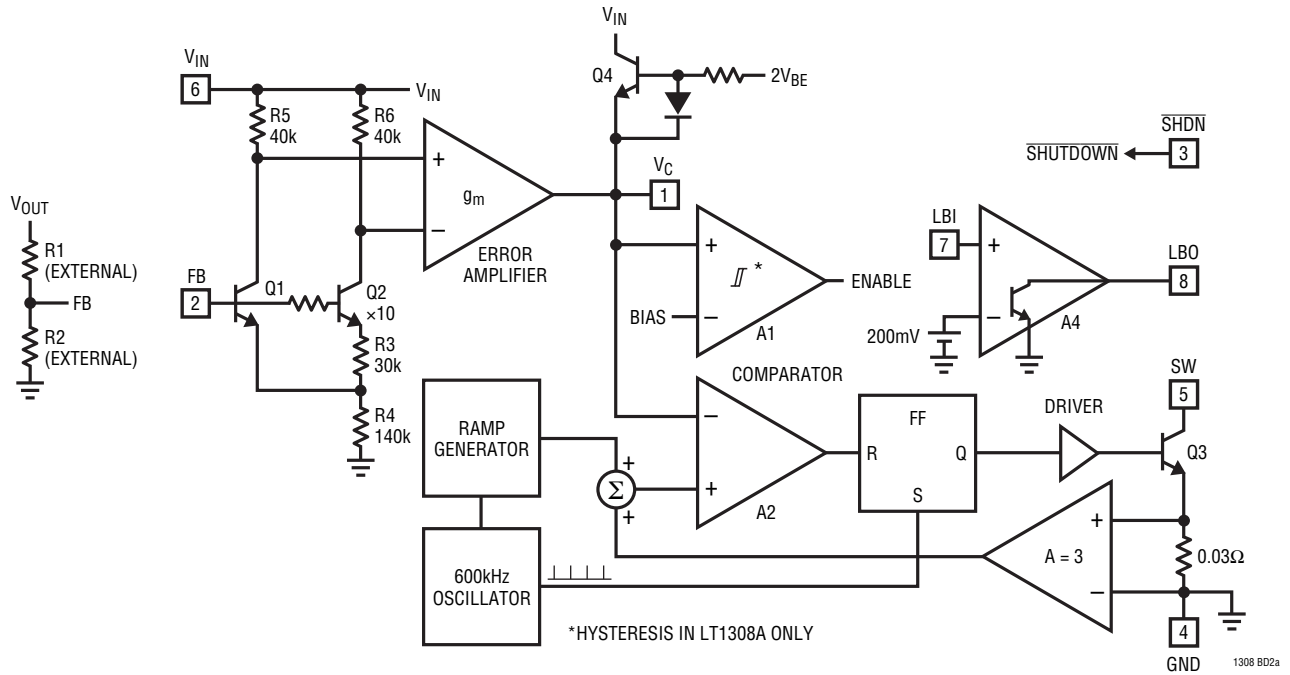


Figure 2a. LT1308A/LT1308B Block Diagram (SO-8 Package)

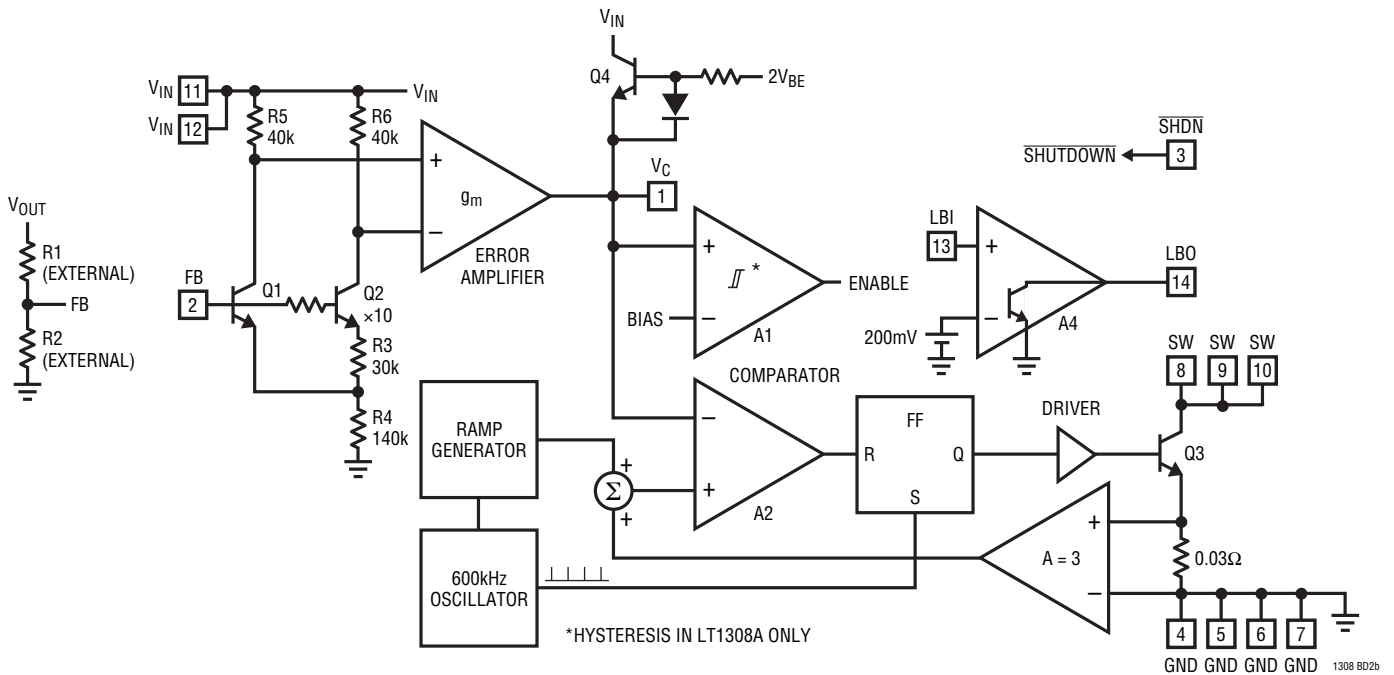


Figure 2b. LT1308A/LT1308B Block Diagram (TSSOP Package)



## APPLICATIONS INFORMATION

### OPERATION

The LT1308A combines a current mode, fixed frequency PWM architecture with Burst Mode micropower operation to maintain high efficiency at light loads. Operation can be best understood by referring to the block diagram in Figure 2. Q1 and Q2 form a bandgap reference core whose loop is closed around the output of the converter. When  $V_{IN}$  is 1V, the feedback voltage of 1.22V, along with an 80mV drop across R5 and R6, forward biases Q1 and Q2's base collector junctions to 300mV. Because this is not enough to saturate either transistor, FB can be at a higher voltage than  $V_{IN}$ . When there is no load, FB rises slightly above 1.22V, causing  $V_C$  (the error amplifier's output) to decrease. When  $V_C$  reaches the bias voltage on hysteretic comparator A1, A1's output goes low, turning off all circuitry except the input stage, error amplifier and low-battery detector. Total current consumption in this state is 140 $\mu$ A. As output loading causes the FB voltage to decrease, A1's output goes high, enabling the rest of the IC. Switch current is limited to approximately 400mA initially after A1's output goes high. If the load is light, the output voltage (and FB voltage) will increase until A1's output goes low, turning off the rest of the LT1308A. Low frequency ripple voltage appears at the output. The ripple frequency is dependent on load current and output capacitance. This Burst Mode operation keeps the output regulated and reduces average current into the IC, resulting in high efficiency even at load currents of 1mA or less.

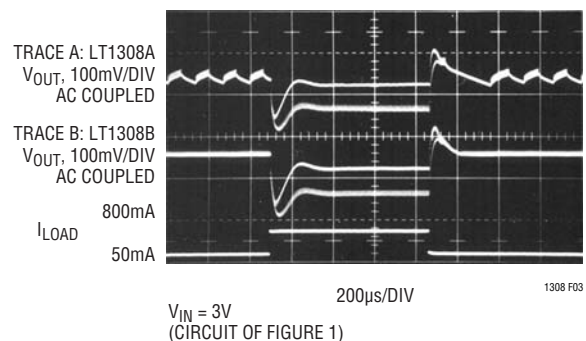
If the output load increases sufficiently, A1's output remains high, resulting in continuous operation. When the LT1308A is running continuously, peak switch current is controlled by  $V_C$  to regulate the output voltage. The switch is turned on at the beginning of each switch cycle. When the summation of a signal representing switch current and a ramp generator (introduced to avoid subharmonic oscillations at duty factors greater than 50%) exceeds the  $V_C$  signal, comparator A2 changes state, resetting the flip-flop and turning off the switch. Output voltage increases as switch current is increased. The output, attenuated by a resistor divider, appears at the FB pin, closing the overall loop. Frequency compensation is provided by an external series RC network connected between the  $V_C$  pin and ground.

Low-battery detector A4's open-collector output (LBO) pulls low when the LBI pin voltage drops below 200mV. There is no hysteresis in A4, allowing it to be used as an amplifier in some applications. The entire device is disabled when the  $\overline{SHDN}$  pin is brought low. To enable the converter,  $\overline{SHDN}$  must be at 1V or greater. It need not be tied to  $V_{IN}$  as on the LT1308.

The LT1308B differs from the LT1308A in that there is no hysteresis in comparator A1. Also, the bias point on A1 is set lower than on the LT1308B so that switching can occur at inductor current less than 100mA. Because A1 has no hysteresis, there is no Burst Mode operation at light loads and the device continues switching at constant frequency. This results in the absence of low frequency output voltage ripple at the expense of efficiency.

The difference between the two devices is clearly illustrated in Figure 3. The top two traces in Figure 3 shows an LT1308A/LT1308B circuit, using the components indicated in Figure 1, set to a 5V output. Input voltage is 3V. Load current is stepped from 50mA to 800mA for both circuits. Low frequency Burst Mode operation voltage ripple is observed on Trace A, while none is observed on Trace B.

At light loads, the LT1308B will begin to skip alternate cycles. The load point at which this occurs can be decreased by increasing the inductor value. However, output ripple will continue to be significantly less than the LT1308A output ripple. Further, the LT1308B can be forced into micropower mode, where  $I_Q$  falls from 3mA to 200 $\mu$ A by sinking 40 $\mu$ A or more out of the  $V_C$  pin. This stops switching by causing A1's output to go low.



**Figure 3. LT1308A Exhibits Burst Mode Operation Output Voltage Ripple at 50mA Load, LT1308B Does Not**



## APPLICATIONS INFORMATION

Waveforms for a LT1308B 5V to 12V boost converter using a 10 $\mu$ F ceramic output capacitor are pictured in Figures 4 and 5. In Figure 4, the converter is operating in continuous mode, delivering a load current of approximately 500mA. The top trace is the output. The voltage increases as inductor current is dumped into the output capacitor during the switch off time, and the voltage decreases when the switch is on. Ripple voltage is in this case due to capacitance, as the ceramic capacitor has little ESR. The middle trace is the switch voltage. This voltage alternates between a  $V_{CESAT}$  and  $V_{OUT}$  plus the diode drop. The lower trace is the switch current. At the beginning of the switch cycle, the current is 1.2A. At the end of the switch on time, the current has increased to 2A, at which point the switch turns off and the inductor current flows into the output capacitor through the diode. Figure 5 depicts converter waveforms at a light load. Here the converter operates in discontinuous mode. The inductor current reaches zero during the switch off time, resulting in some ringing at the switch node. The ring frequency is set by switch capacitance, diode capacitance and inductance. This ringing has little energy, and its sinusoidal shape suggests it is free from harmonics. Minimizing the copper area at the switch node will prevent this from causing interference problems.

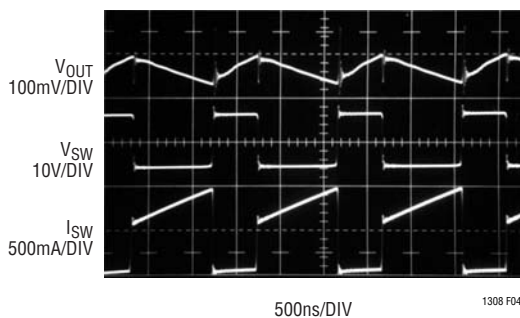


Figure 4. 5V to 12V Boost Converter Waveforms in Continuous Mode. 10 $\mu$ F Ceramic Capacitor Used at Output

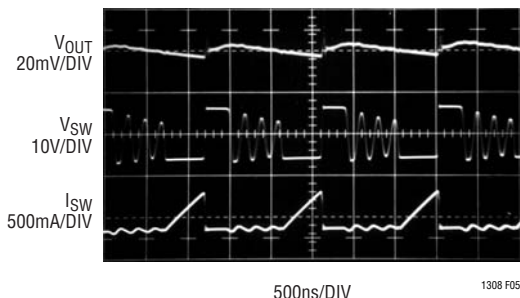


Figure 5. Converter Waveforms in Discontinuous Mode

## LAYOUT HINTS

The LT1308A/LT1308B switch current at high speed, mandating careful attention to layout for proper performance. *You will not get advertised performance with careless layout.* Figure 6 shows recommended component placement for an SO-8 package boost (step-up) converter. Follow this closely in your PC layout. Note the direct path of the switching loops. Input capacitor  $C1$  *must* be placed close (<5mm) to the IC package. As little as 10mm of wire or PC trace from  $C_{IN}$  to  $V_{IN}$  will cause problems such as inability to regulate or oscillation.

The negative terminal of output capacitor  $C2$  should tie close to the ground pin(s) of the LT1308A/LT1308B. Doing this reduces  $di/dt$  in the ground copper which keeps high frequency spikes to a minimum. The DC/DC converter ground should tie to the PC board ground plane at one place only, to avoid introducing  $di/dt$  in the ground plane.

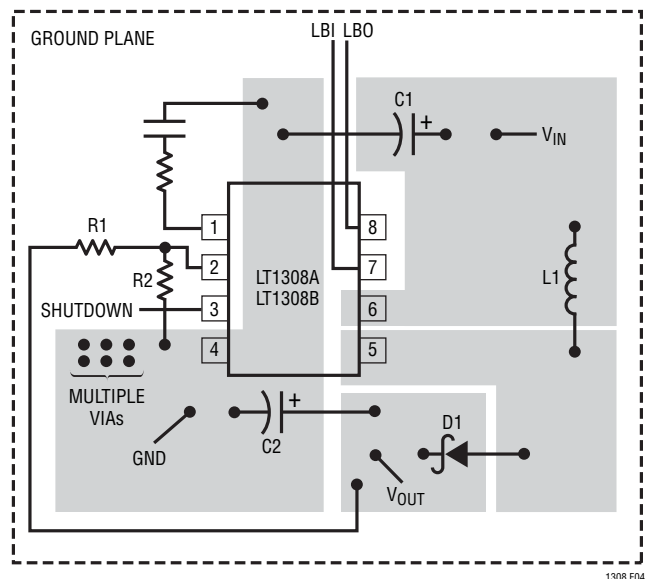
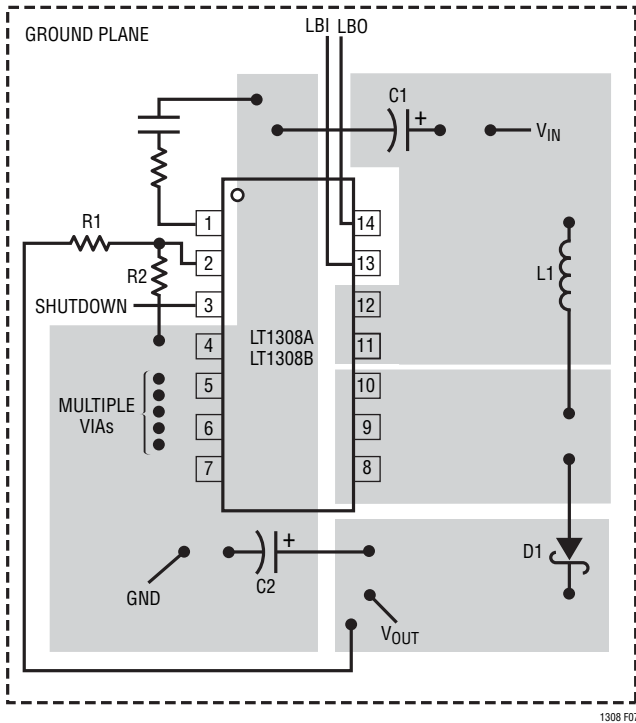


Figure 6. Recommended Component Placement for SO-8 Package Boost Converter. Note Direct High Current Paths Using Wide PC Traces. Minimize Trace Area at Pin 1 ( $V_C$ ) and Pin 2 (FB). Use Multiple Vias to Tie Pin 4 Copper to Ground Plane. Use Vias at One Location Only to Avoid Introducing Switching Currents into the Ground Plane

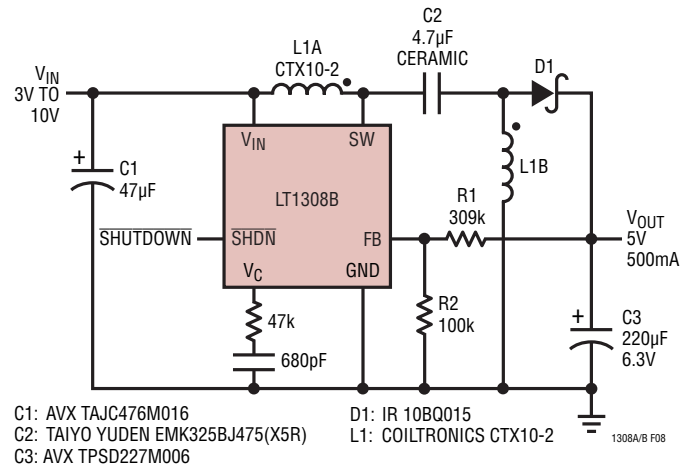
Figure 7 shows recommended component placement for a boost converter using the TSSOP package. Placement is similar to the SO-8 package layout.

## APPLICATIONS INFORMATION

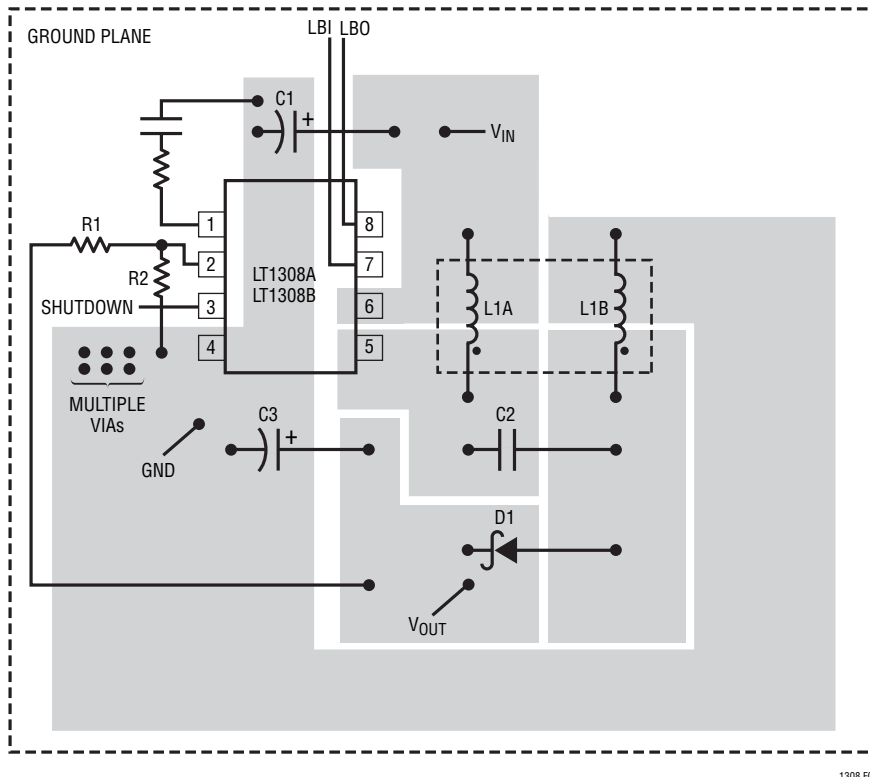


**Figure 7. Recommended Component Placement for TSSOP Boost Converter. Placement is Similar to Figure 4**

A SEPIC (Single-Ended Primary Inductance Converter) schematic is shown in Figure 8. This converter topology produces a regulated output over an input voltage range that spans (i.e., can be higher or lower than) the output. Recommended component placement for an SO-8 package SEPIC is shown in Figure 9.



**Figure 8. SEPIC (Single-Ended Primary Inductance Converter) Converts 3V to 10V Input to a 5V/500mA Regulated Output**



**Figure 9. Recommended Component Placement for SEPIC**

## APPLICATIONS INFORMATION

### SHDN PIN

The LT1308A/LT1308B  $\overline{\text{SHDN}}$  pin is improved over the LT1308. The pin does not require tying to  $V_{\text{IN}}$  to enable the device, but needs only a logic level signal. The voltage on the  $\overline{\text{SHDN}}$  pin can vary from 1V to 10V independent of  $V_{\text{IN}}$ . Further, floating this pin has the same effect as grounding, which is to shut the device down, reducing current drain to 1 $\mu\text{A}$  or less.

### LOW-BATTERY DETECTOR

The low-battery detector on the LT1308A/LT1308B features improved accuracy and drive capability compared to the LT1308. The 200mV reference has an accuracy of  $\pm 2\%$  and the open-collector output can sink 50 $\mu\text{A}$ . The LT1308A/LT1308B low-battery detector is a simple PNP input gain stage with an open-collector NPN output. The negative input of the gain stage is tied internally to a 200mV reference. The positive input is the LBI pin. Arrangement as a low-battery detector is straightforward. Figure 10 details hookup. R1 and R2 need only be low enough in value so that the bias current of the LBI pin doesn't cause large errors. For R2, 100k is adequate. The 200mV reference can also be accessed as shown in Figure 11.

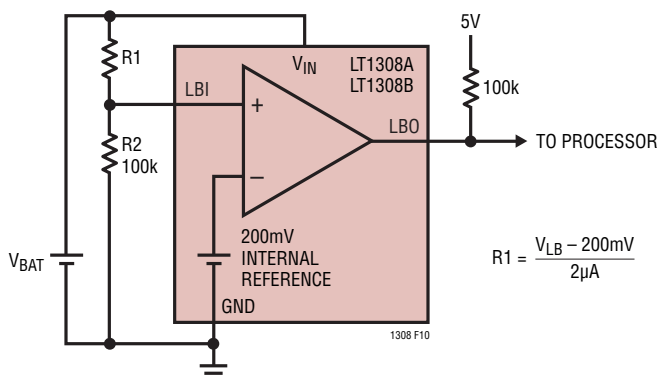


Figure 10. Setting Low-Battery Detector Trip Point

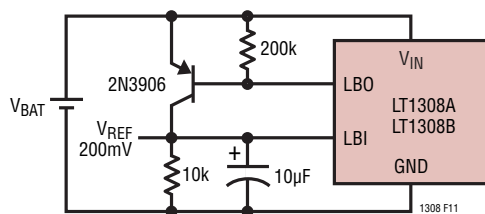


Figure 11. Accessing 200mV Reference

A cross plot of the low-battery detector is shown in Figure 12. The LBI pin is swept with an input which varies from 195mV to 205mV, and LBO (with a 100k pull-up resistor) is displayed.

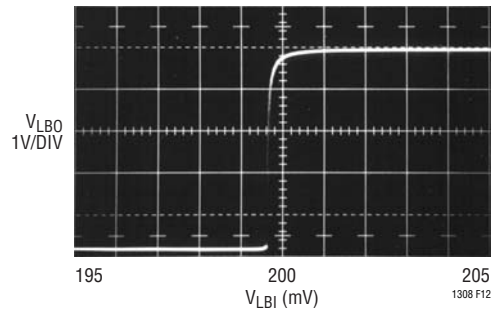


Figure 12. Low-Battery Detector Input/Output Characteristic

### START-UP

The LT1308A/LT1308B can start up into heavy loads, unlike many CMOS DC/DC converters that derive operating voltage from the output (a technique known as “bootstrapping”). Figure 13 details start-up waveforms of Figure 1's circuit with a 20 $\Omega$  load and  $V_{\text{IN}}$  of 1.5V. Inductor current rises to 3.5A as the output capacitor is charged. After the output reaches 5V, inductor current is about 1A. In Figure 14, the load is 5 $\Omega$  and input voltage is 3V. Output voltage reaches 5V in 500 $\mu\text{s}$  after the device is enabled. Figure 15 shows start-up behavior of Figure 5's SEPIC circuit, driven from a 9V input with a 10 $\Omega$  load. The output reaches 5V in about 1ms after the device is enabled.

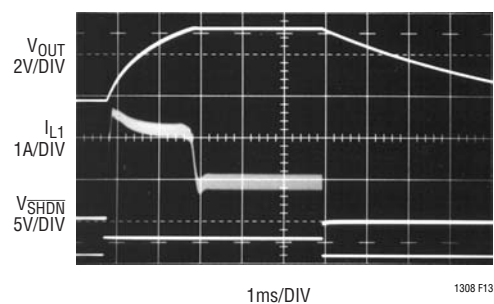
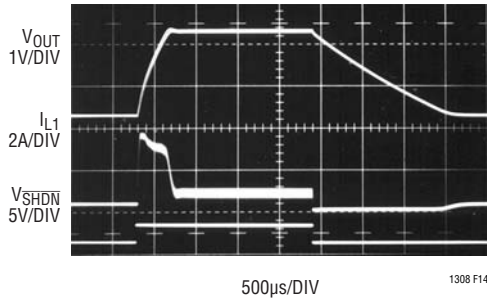
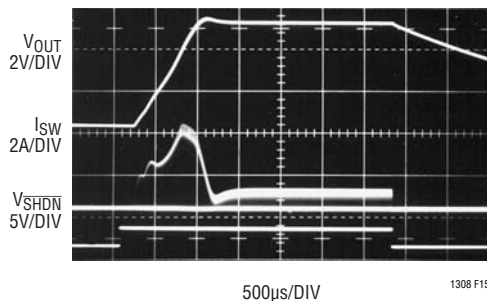


Figure 13. 5V Boost Converter of Figure 1. Start-Up from 1.5V Input into 20 $\Omega$  Load

## APPLICATIONS INFORMATION



**Figure 14. 5V Boost Converter of Figure 1. Start-Up from 3V Input into 5Ω Load**



**Figure 15. 5V SEPIC Start-Up from 9V Input into 10Ω Load**

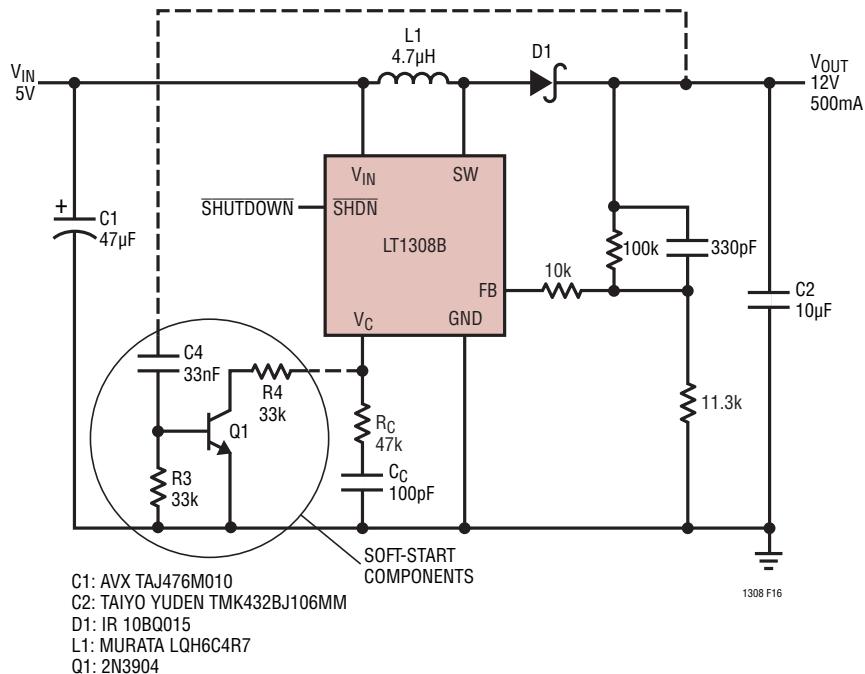
### Soft-Start

In some cases it may be undesirable for the LT1308A/LT1308B to operate at current limit during start-up, e.g.,

when operating from a battery composed of alkaline cells. The inrush current may cause sufficiency internal voltage drop to trigger a low-battery indicator. A programmable soft-start can be implemented with 4 discrete components. A 5V to 12V boost converter using the LT1308B is detailed in Figure 16. C4 differentiates  $V_{OUT}$ , causing a current to flow into R3 as  $V_{OUT}$  increases. When this current exceeds  $0.7V/33k$ , or  $21\mu A$ , current flows into the base of Q1. Q1's collector then pulls current out the  $V_C$  pin, creating a feedback loop where the slope of  $V_{OUT}$  is limited as follows:

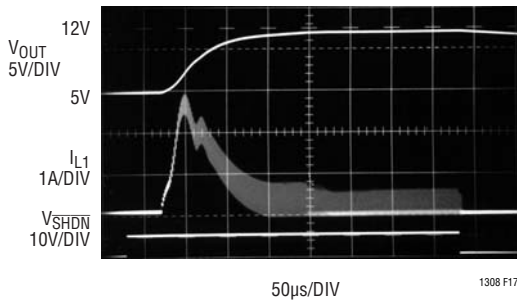
$$\frac{\Delta V_{OUT}}{\Delta t} = \frac{0.7V}{33k \cdot C4}$$

With  $C4 = 33nF$ ,  $V_{OUT}/t$  is limited to 640mV/ms. Start-up waveforms for Figure 16's circuit are pictured in Figure 17. Without the soft-start circuit implemented, the inrush current reaches 3A. The circuit reaches final output voltage in approximately 250µs. Adding the soft-start components reduces inductor current to less than 1A, as detailed in Figure 18, while the time required to reach final output voltage increases to about 15ms. C4 can be adjusted to achieve any output slew rate desired.

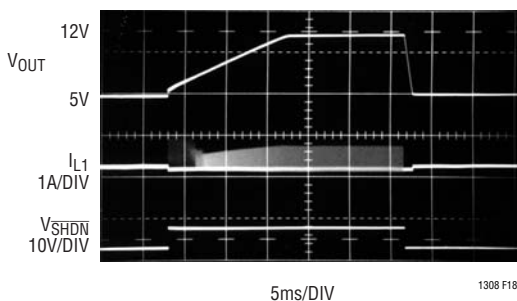


**Figure 16. 5V to 12V Boost Converter with Soft-Start Components Q1, C4, R3 and R4**

## APPLICATIONS INFORMATION



**Figure 17. Start-Up Waveforms of Figure 16's Circuit without Soft-Start Components**



**Figure 18. Start-Up Waveforms of Figure 16's Circuit with Soft-Start Components Added**

### COMPONENT SELECTION

#### Diodes

We have found ON Semiconductor MBRS130 and International Rectifier 10BQ015 to perform well. For applications where  $V_{OUT}$  exceeds 30V, use 40V diodes such as MBRS140 or 10BQ040.

Height limited applications may benefit from the use of the MBRM120. This component is only 1mm tall and offers performance similar to the MBRS130.

#### Inductors

Suitable inductors for use with the LT1308A/LT1308B must fulfill two requirements. First, the inductor must be able to handle current of 2A steady-state, as well as support transient and start-up current over 3A without inductance decreasing by more than 50% to 60%. Second, the DCR of the inductor should have low DCR, under 0.05 $\Omega$  so

that copper loss is minimized. Acceptable inductance values range between 2 $\mu$ H and 20 $\mu$ H, with 4.7 $\mu$ H best for most applications. Lower value inductors are physically smaller than higher value inductors for the same current capability.

Table 1 lists some inductors we have found to perform well in LT1308A/LT1308B application circuits. This is not an exclusive list.

**Table 1**

VENDOR	PART NO.	VALUE	PHONE NO.
Murata	LQH6C4R7	4.7 $\mu$ H	770-436-1300
Sumida	CDRH734R7	4.7 $\mu$ H	847-956-0666
Coiltronics	CTX5-1	5 $\mu$ H	561-241-7876
Coilcraft	LPO2506IB-472	4.7 $\mu$ H	847-639-6400

#### Capacitors

Equivalent Series Resistance (ESR) is the main issue regarding selection of capacitors, especially the output capacitors.

The output capacitors specified for use with the LT1308A/LT1308B circuits have low ESR and are specifically designed for power supply applications. Output voltage ripple of a boost converter is equal to ESR multiplied by switch current. The performance of the AVX TPSD227M006 220 $\mu$ F tantalum can be evaluated by referring to Figure 3. When the load is 800mA, the peak switch current is approximately 2A. Output voltage ripple is about 60mV<sub>P-P</sub>, so the ESR of the output capacitor is 60mV/2A or 0.03 $\Omega$ . Ripple can be further reduced by paralleling ceramic units.

Table 2 lists some capacitors we have found to perform well in the LT1308A/LT1308B application circuits. This is not an exclusive list.

**Table 2**

VENDOR	SERIES	PART NO.	VALUE	PHONE NO.
AVX	TPS	TPSD227M006	220 $\mu$ F, 6V	803-448-9411
AVX	TPS	TPSD107M010	100 $\mu$ F, 10V	803-448-9411
Taiyo Yuden	X5R	LMK432BJ226	22 $\mu$ F, 10V	408-573-4150
Taiyo Yuden	X5R	TMK432BJ106	10 $\mu$ F, 25V	408-573-4150



## APPLICATIONS INFORMATION

### Ceramic Capacitors

Multilayer ceramic capacitors have become popular, due to their small size, low cost, and near-zero ESR. Ceramic capacitors can be used successfully in LT1308A/LT1308B designs provided loop stability is considered. A tantalum capacitor has some ESR and this causes an "ESR zero" in the regulator loop. This zero is beneficial to loop stability. Ceramics do not have appreciable ESR, so the zero is lost when they are used. However, the LT1308A/LT1308B have external compensation pin ( $V_C$ ) so component values can be adjusted to achieve stability. A phase lead capacitor can also be used to tune up load step response to optimum levels, as detailed in the following paragraphs.

Figure 19 details a 5V to 12V boost converter using either a tantalum or ceramic capacitor for C2. The input capacitor has little effect on loop stability, as long as minimum capacitance requirements are met. The phase lead capacitor  $C_{PL}$  parallels feedback resistor R1. Figure 20 shows load step response of a 50mA to 500mA load step using a 47 $\mu$ F tantalum capacitor at the output. Without the phase lead capacitor, there is some ringing, suggesting the phase margin is low.  $C_{PL}$  is then added, and response to the same load step is pictured in Figure 21. Some phase margin is restored, improving the response. Next, C2 is replaced by a 10 $\mu$ F, X5R dielectric, ceramic capacitor.

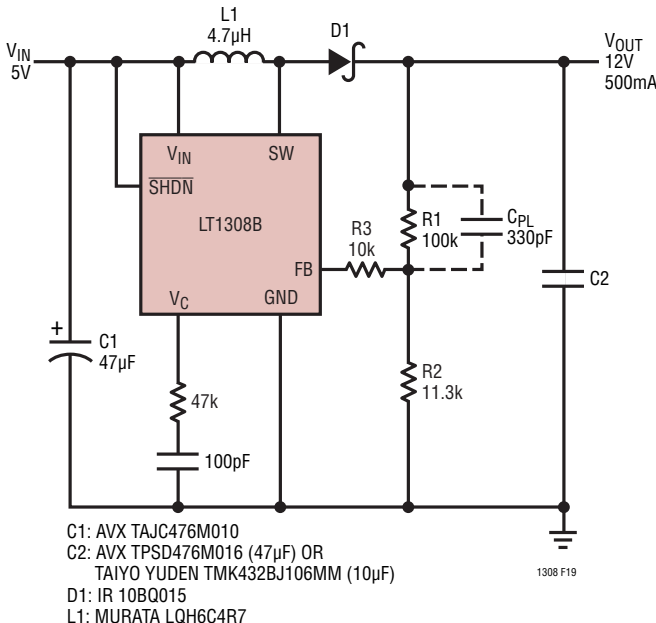


Figure 19. 5V to 12V Boost Converter

Without  $C_{PL}$ , load step response is pictured in Figure 22. Although the output settles faster than the tantalum case, there is appreciable ringing, again suggesting phase margin is low. Figure 23 depicts load step response using the 10 $\mu$ F ceramic output capacitor and  $C_{PL}$ . Response is clean and no ringing is evident. Ceramic capacitors have the added benefit of lowering ripple at the switching frequency due to their very low ESR. By applying  $C_{PL}$  in tandem with the series RC at the  $V_C$  pin, loop response can be tailored to optimize response using ceramic output capacitors.

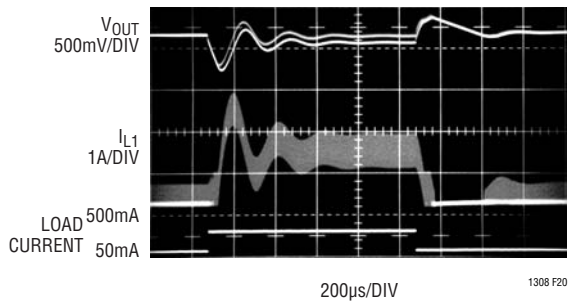


Figure 20. Load Step Response of LT1308B 5V to 12V Boost Converter with 47 $\mu$ F Tantalum Output Capacitor

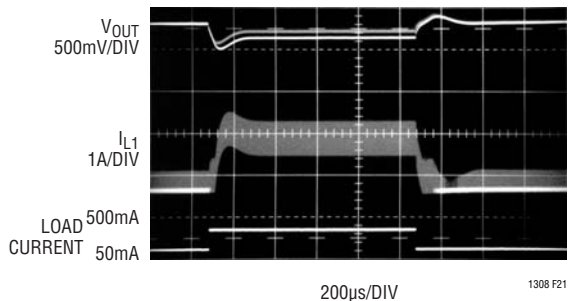


Figure 21. Load Step Response with 47 $\mu$ F Tantalum Output Capacitor and Phase Lead Capacitor  $C_{PL}$

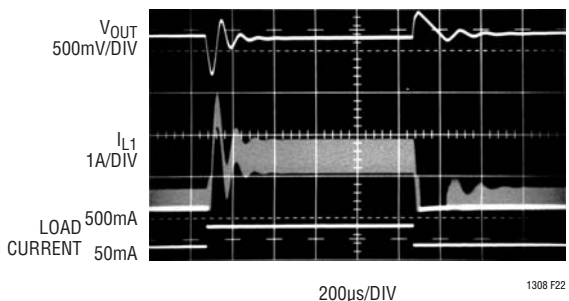
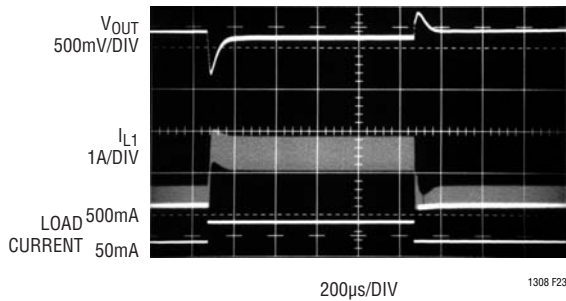


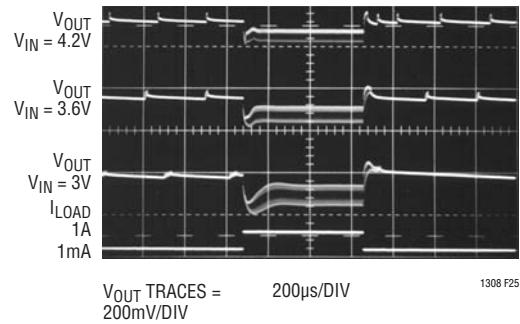
Figure 22. Load Step Response with 10 $\mu$ F X5R Ceramic Output Capacitor

1308abfb

## APPLICATIONS INFORMATION



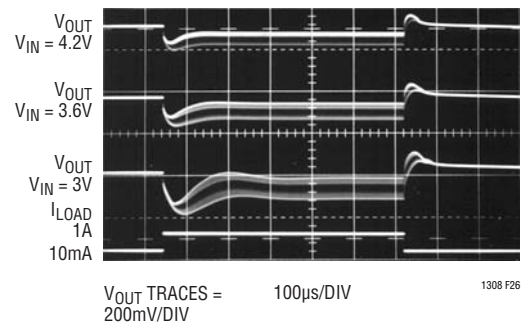
**Figure 23. Load Step Response with 10µF X5R Ceramic Output Capacitor and C<sub>pl</sub>**



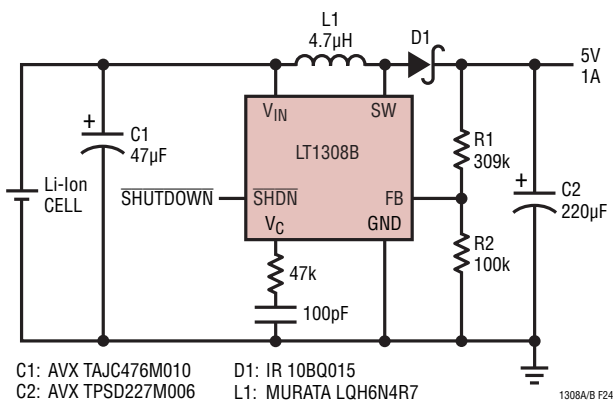
**Figure 25. LT1308A Li-Ion to 5V Boost Converter Transient Response to 1A Load Step**

### GSM AND CDMA PHONES

The LT1308A/LT1308B are suitable for converting a single Li-Ion cell to 5V for powering RF power stages in GSM or CDMA phones. Improvements in the LT1308A/LT1308B error amplifiers allow external compensation values to be reduced, resulting in faster transient response compared to the LT1308. The circuit of Figure 24 (same as Figure 1, printed again for convenience) provides a 5V, 1A output from a Li-Ion cell. Figure 25 details transient response at the LT1308A operating at a  $V_{IN}$  of 4.2V, 3.6V and 3V. Ripple voltage in Burst Mode operation can be seen at 10mA load. Figure 26 shows transient response of the LT1308B under the same conditions. Note the lack of Burst Mode ripple at 10mA load.



**Figure 26. LT1308B Li-Ion to 5V Boost Converter Transient Response to 1A Load Step**

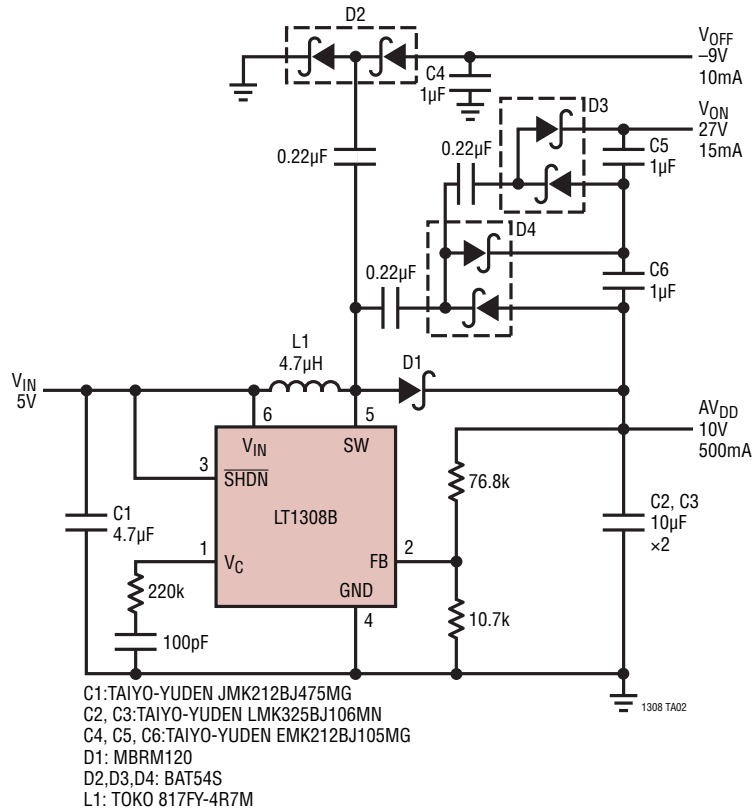


**Figure 24. Li-Ion to 5V Boost Converter Delivers 1A**

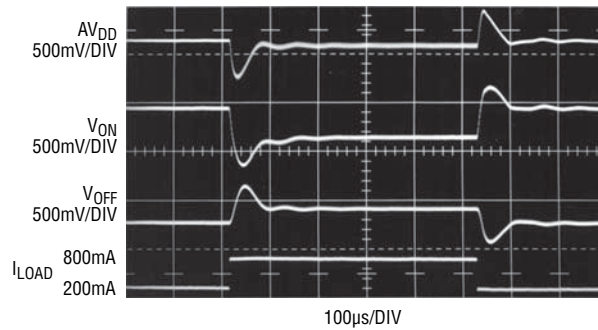


## TYPICAL APPLICATIONS

### Triple Output TFTLCD Bias Supply

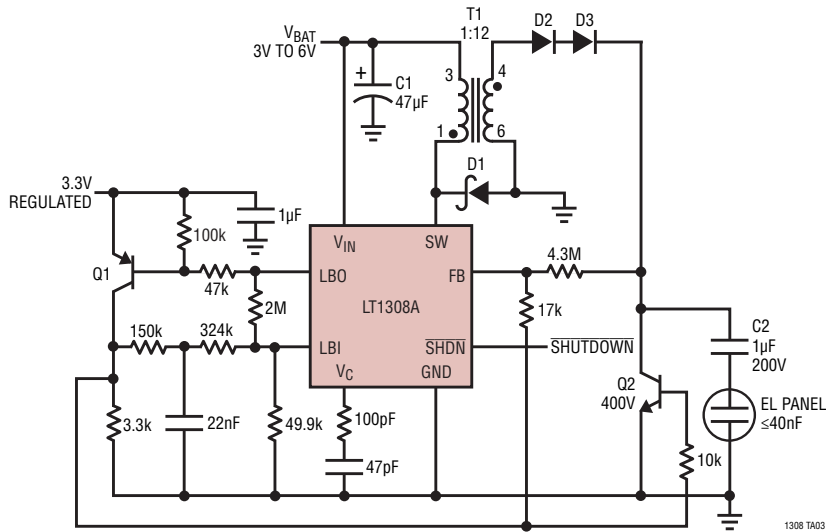


### TFTLCD Bias Supply Transient Response



TYPICAL APPLICATIONS

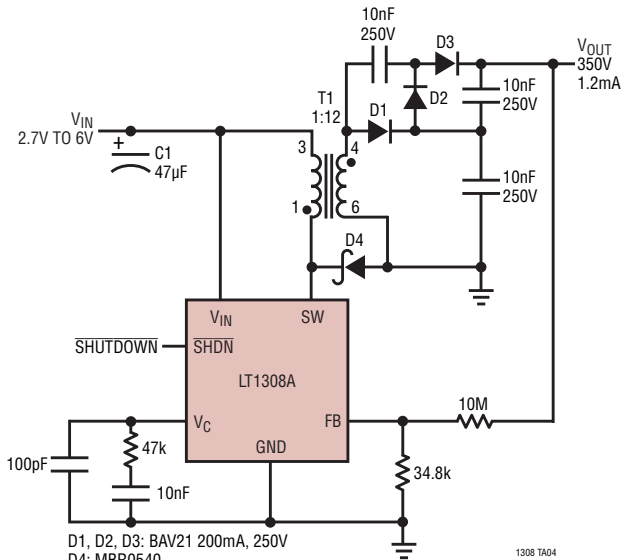
40nF EL Panel Driver



- C1: AVX TAJC476M010
- C2: VITRAMON VJ225Y105KXCAT
- D1: BAT54
- D2, D3: BAV21
- Q1: MMBT3906
- Q2: ZETEX FCX458
- T1: MIDCOM 31105

1308 TA03

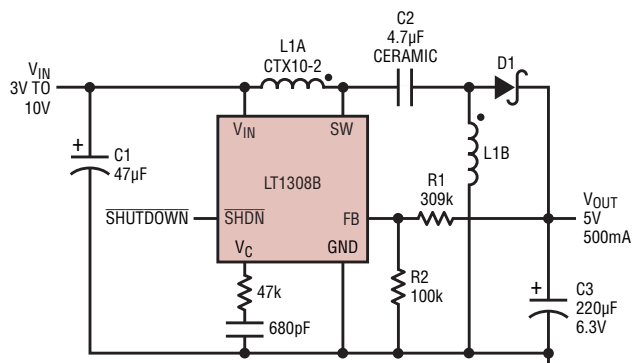
High Voltage Supply 350V at 1.2mA



- D1, D2, D3: BAV21 200mA, 250V
- D4: MBR0540
- T1: MIDCOM 31105R  $L_p = 1.5\mu\text{H}$

1308 TA04

SEPIC Converts 3V to 10V Input to a 5V/500mA Regulated Output

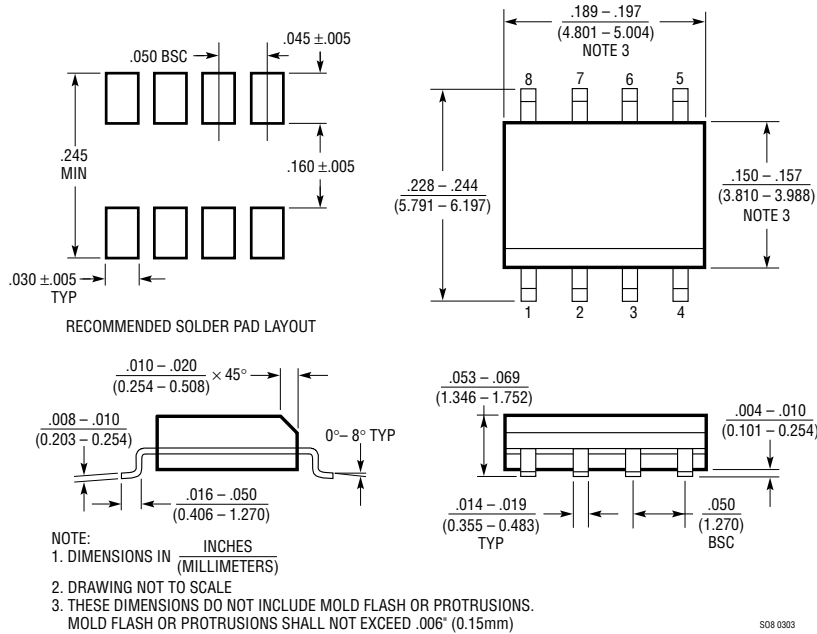


- C1: AVX TAJC476M016
- C2: TAIYO YUDEN EMK325BJ475(X5R)
- C3: AVX TPSD227M006
- D1: IR 10BQ015
- L1: COILTRONICS CTX10-2

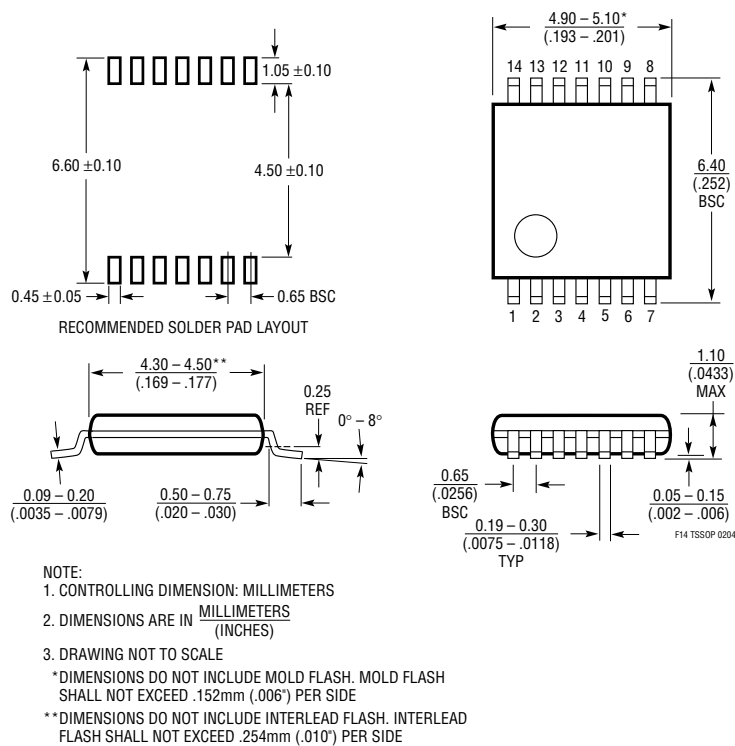
1308A/B TA05

## PACKAGE DESCRIPTION

### S8 Package 8-Lead Plastic Small Outline (Narrow .150 Inch) (Reference LTC DWG # 05-08-1610)



### F Package 14-Lead Plastic TSSOP (4.4mm) (Reference LTC DWG # 05-08-1650)



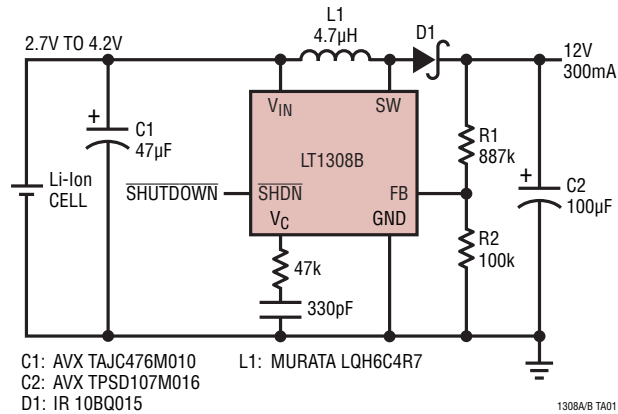
**REVISION HISTORY** (Revision history begins at Rev B)

REV	DATE	DESCRIPTION	PAGE NUMBER
B	12/10	Obsoleted F Package	2

# LT1308A/LT1308B

## TYPICAL APPLICATION

### Li-Ion to 12V/300mA Step-Up DC/DC Converter



## RELATED PARTS

PART NUMBER	DESCRIPTION	COMMENTS
LT1302	High Output Current Micropower DC/DC Converter	5V/600mA from 2V, 2A Internal Switch, 200µA I <sub>Q</sub>
LT1304	2-Cell Micropower DC/DC Converter	5V/200mA, Low-Battery Detector Active in Shutdown
LT1307/LT1307B	Single Cell, Micropower, 600kHz PWM DC/DC Converters	3.3V at 75mA from One Cell, MSOP Package
LT1316	Burst Mode Operation DC/DC with Programmable Current Limit	1.5V Minimum, Precise Control of Peak Current Limit
LT1317/LT1317B	Micropower, 600kHz PWM DC/DC Converters	100µA I <sub>Q</sub> , Operate with V <sub>IN</sub> as Low as 1.5V
LTC <sup>®</sup> 1474	Micropower Step-Down DC/DC Converter	94% Efficiency, 10µA I <sub>Q</sub> , 9V to 5V at 250mA
LTC1516	2-Cell to 5V Regulated Charge Pump	12µA I <sub>Q</sub> , No Inductors, 5V at 50mA from 3V Input
LTC1522	Micropower, 5V Charge Pump DC/DC Converter	Regulated 5V ± 4% Output, 20mA from 3V Input
LT1610	Single-Cell Micropower DC/DC Converter	3V at 30mA from 1V, 1.7MHz Fixed Frequency
LT1611	Inverting 1.4MHz Switching Regulator in 5-Lead SOT-23	-5V at 150mA from 5V Input, Tiny SOT-23 package
LT1613	1.4MHz Switching Regulator in 5-Lead SOT-23	5V at 200mA from 4.4V Input, Tiny SOT-23 package
LT1615	Micropower Step-Up DC/DC in 5-Lead SOT-23	20µA I <sub>Q</sub> , 36V, 350mA Switch
LT1617	Micropower Inverting DC/DC Converter in SOT-23	V <sub>IN</sub> = 1V to 15V; V <sub>OUT</sub> to -34V
LTC1682	Doubler Charge Pump with Low Noise LDO	Adjustable or Fixed 3.3V, 5V Outputs, 60µV <sub>RMS</sub> Output Noise
LT1949	600kHz, 1A Switch PWM DC/DC Converter	1.1A, 0.5Ω, 30V Internal Switch, V <sub>IN</sub> as Low as 1.5V
LT1949-1	1.1MHz, 1A Switch DC/DC Converter	1.1MHz Version of LT1949

1308abfb