

FEATURES

- Uses Tiny Capacitors and Inductor
- Internally Compensated
- Low Quiescent Current: 30 μ A
- Operates with V_{IN} as Low as 1V
- 3V at 30mA from a Single Cell
- 5V at 200mA from 3.3V
- High Output Voltage Capability: Up to 28V
- Low Shutdown Current: < 1 μ A
- Automatic Burst Mode™ Switching at Light Load
- Low V_{CESAT} Switch: 300mV at 300mA
- 8-Lead MSOP and SO Packages

APPLICATIONS

- Pagers
- Cordless Phones
- Battery Backup
- LCD Bias
- Portable Electronic Equipment

DESCRIPTION

The LT[®]1610 is a micropower fixed frequency DC/DC converter that operates from an input voltage as low as 1V. Intended for small, low power applications, it switches at 1.7MHz, allowing the use of tiny capacitors and inductors.

The device can generate 3V at 30mA from a single cell (1V) supply. An internal compensation network can be connected to the LT1610's V_C pin, eliminating two external components. No-load quiescent current of the LT1610 is 30 μ A, and the internal NPN power switch handles a 300mA current with a voltage drop of 300mV.

The LT1610 is available in 8-lead MSOP and SO packages.

LT, LTC and LT are registered trademarks of Linear Technology Corporation.
Burst Mode is a trademark of Linear Technology Corporation.

TYPICAL APPLICATION

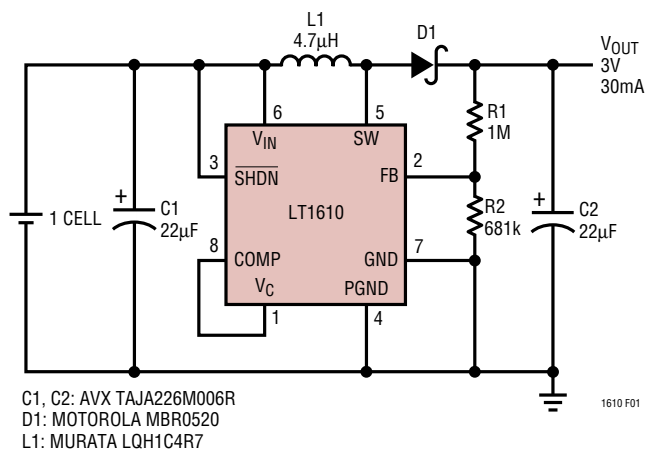
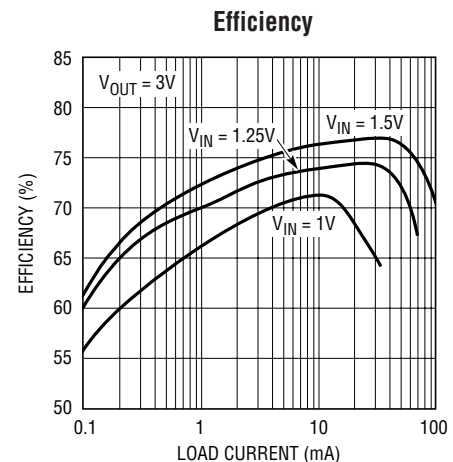

Figure 1. 1-Cell to 3V Step-Up Converter



1610 TA01

LT1610

ABSOLUTE MAXIMUM RATINGS

(Note 1)

V_{IN} Voltage	8V	Maximum Junction Temperature	125°C
SW Voltage	-0.4V to 30V	Operating Temperature Range (Note 1)	
FB Voltage	$V_{IN} + 0.3V$	Commercial	0°C to 70°C
V_C Voltage	2V	Extended Commercial (Note 2)	-40°C to 85°C
COMP Voltage	2V	Industrial	-40°C to 85°C
Current into FB Pin	$\pm 1mA$	Storage Temperature Range	-65°C to 150°C
SHDN Voltage	8V	Lead Temperature (Soldering, 10 sec)	300°C

PACKAGE/ORDER INFORMATION

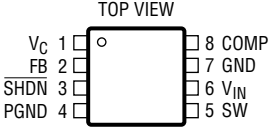
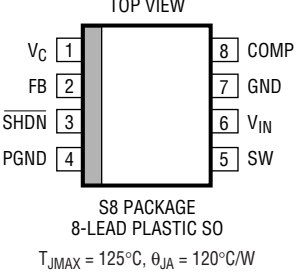
 <p>MS8 PACKAGE 8-LEAD PLASTIC MSOP $T_{JMAX} = 125^{\circ}C, \theta_{JA} = 160^{\circ}C/W$</p>	ORDER PART NUMBER	 <p>S8 PACKAGE 8-LEAD PLASTIC SO $T_{JMAX} = 125^{\circ}C, \theta_{JA} = 120^{\circ}C/W$</p>	ORDER PART NUMBER
	LT1610CMS8		LT1610CS8 LT1610IS8
	MS8 PART MARKING		S8 PART MARKING
	LTDT		1610 1610I

Consult factory for Military grade parts.

ELECTRICAL CHARACTERISTICS

The ● denotes specifications which apply over the specified temperature range, otherwise specifications are at $T_A = 25^{\circ}C$. Commercial grade 0°C to 70°C, $V_{IN} = 1.5V$, $V_{SHDN} = V_{IN}$, unless otherwise noted. (Note 2)

PARAMETER	CONDITIONS	MIN	TYP	MAX	UNITS
Minimum Operating Voltage			0.9	1	V
Maximum Operating Voltage				8	V
Feedback Voltage		● 1.20	1.23	1.26	V
Quiescent Current	$V_{SHDN} = 1.5V$, Not Switching		30	60	μA
Quiescent Current in Shutdown	$V_{SHDN} = 0V, V_{IN} = 2V$		0.01	0.5	μA
	$V_{SHDN} = 0V, V_{IN} = 5V$		0.01	1.0	μA
FB Pin Bias Current		●	27	80	nA
Reference Line Regulation	$1V \leq V_{IN} \leq 2V$ (25°C, 0°C)		0.6	1	%/V
	$1V \leq V_{IN} \leq 2V$ (70°C)			2	%/V
	$2V \leq V_{IN} \leq 8V$ (25°C, 0°C)		0.03	0.15	%/V
	$2V \leq V_{IN} \leq 8V$ (70°C)			0.2	%/V
Error Amp Transconductance	$\Delta I = 2\mu A$		25		$\mu mhos$
Error Amp Voltage Gain			100		V/V
Switching Frequency		● 1.4	1.7	2	MHz
Maximum Duty Cycle		● 77	80	95	%
		● 75		95	%

ELECTRICAL CHARACTERISTICS

The ● denotes specifications which apply over the specified temperature range, otherwise specifications are at $T_A = 25^\circ\text{C}$. Commercial grade 0°C to 70°C , $V_{\text{IN}} = 1.5\text{V}$, $V_{\text{SHDN}} = V_{\text{IN}}$, unless otherwise noted. (Note 2)

PARAMETER	CONDITIONS	MIN	TYP	MAX	UNITS
Switch Current Limit	(Note 3)	450	600	900	mA
Switch V_{CESAT}	$I_{\text{SW}} = 300\text{mA}$		300	350 400	mV mV
Switch Leakage Current	$V_{\text{SW}} = 5\text{V}$		0.01	1	μA
$\overline{\text{SHDN}}$ Input Voltage High		1			V
$\overline{\text{SHDN}}$ Input Voltage Low				0.3	V
$\overline{\text{SHDN}}$ Pin Bias Current	$V_{\text{SHDN}} = 3\text{V}$ $V_{\text{SHDN}} = 0\text{V}$		10 0.01	0.1	μA μA

The ● denotes specifications which apply over the specified temperature range, otherwise specifications are at $T_A = 25^\circ\text{C}$. Industrial grade -40°C to 85°C , $V_{\text{IN}} = 1.5\text{V}$, $V_{\text{SHDN}} = V_{\text{IN}}$, unless otherwise noted.

PARAMETER	CONDITIONS	MIN	TYP	MAX	UNITS
Minimum Operating Voltage	$T_A = 85^\circ\text{C}$ $T_A = -40^\circ\text{C}$		0.9	1 1.25	V V
Maximum Operating Voltage				8	V
Feedback Voltage		● 1.20	1.23	1.26	V
Quiescent Current			30	60	μA
Quiescent Current in Shutdown	$V_{\text{SHDN}} = 0\text{V}$, $V_{\text{IN}} = 2\text{V}$ $V_{\text{SHDN}} = 0\text{V}$, $V_{\text{IN}} = 5\text{V}$		0.01 0.01	0.5 1.0	μA μA
FB Pin Bias Current		●	27	80	nA
Reference Line Regulation	$2\text{V} \leq V_{\text{IN}} \leq 8\text{V}$ (-40°C) $2\text{V} \leq V_{\text{IN}} \leq 8\text{V}$ (85°C)		0.03	0.15 0.2	%/V %/V
Error Amp Transconductance	$\Delta I = 2\mu\text{A}$		25		μmhos
Error Amp Voltage Gain			100		V/V
Switching Frequency	(Note 4)	● 1.4	1.7	2	MHz
Maximum Duty Cycle	(Note 4)	● 77 75	80	95 95	% %
Switch Current Limit		450	600	900	mA
Switch V_{CESAT}	$I_{\text{SW}} = 300\text{mA}$		300	350 400	mV mV
Switch Leakage Current	$V_{\text{SW}} = 5\text{V}$		0.01	1	μA
$\overline{\text{SHDN}}$ Input Voltage High		1			V
$\overline{\text{SHDN}}$ Input Voltage Low				0.3	V
$\overline{\text{SHDN}}$ Pin Bias Current	$V_{\text{SHDN}} = 3\text{V}$ $V_{\text{SHDN}} = 0\text{V}$		10 0.01	0.1	μA μA

Note 1: Absolute Maximum Ratings are those values beyond which the life of a device may be impaired.

Note 2: The LT1610C is guaranteed to meet specified performance from 0°C to 70°C and is designed, characterized and expected to meet these extended temperature limits, but is not tested at -40°C and 85°C . The LT1610I is guaranteed to meet the extended temperature limits.

Note 3: Current limit guaranteed by design and/or correlation to static test. Current limit is affected by duty cycle due to ramp generator. See Block Diagram.

Note 4: Not 100% tested at 85°C .

TYPICAL PERFORMANCE CHARACTERISTICS

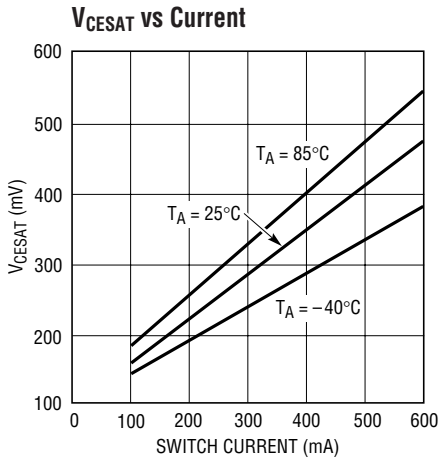

1610 G01

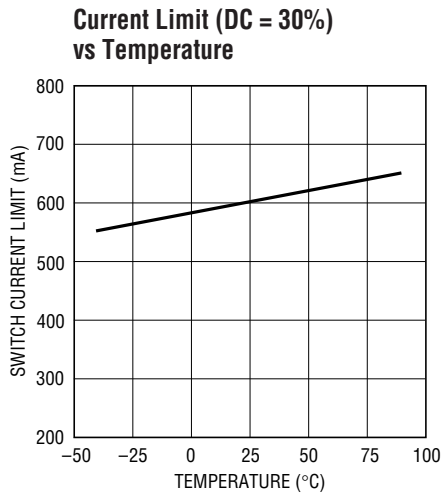

1610 G02

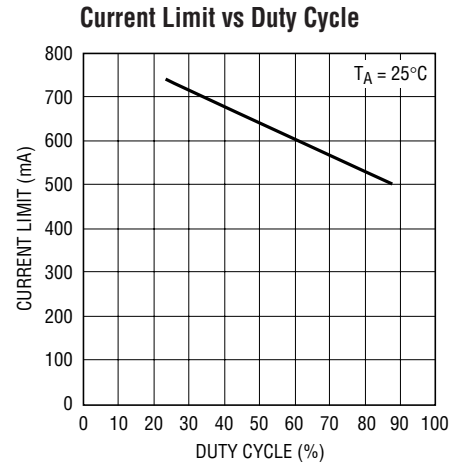

1610 G03

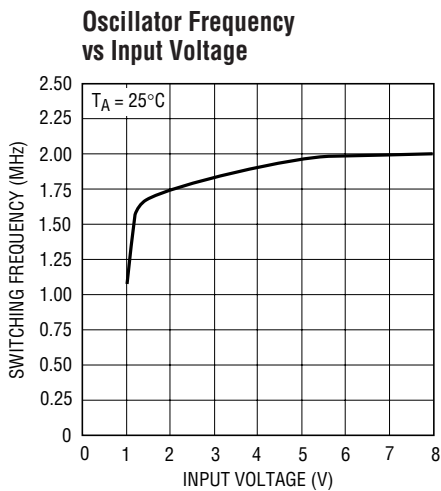

1610 G04

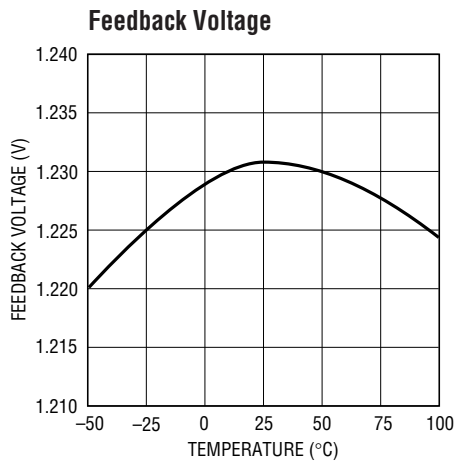

1610 G05

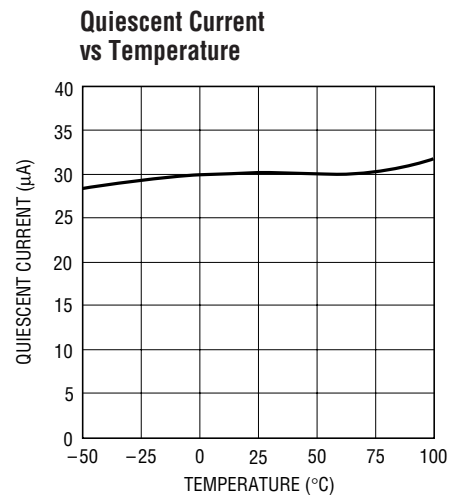

1610 G06

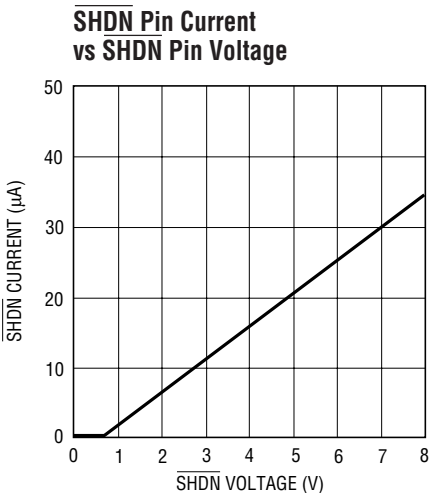

1610 G07

Transient Response, Circuit of Figure 1

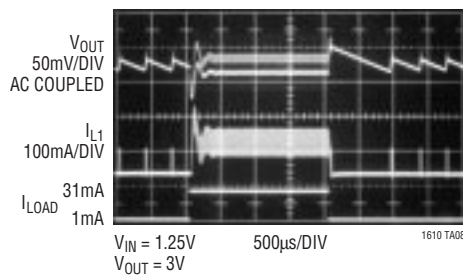

1610 TA08

Burst Mode Operation, Circuit of Figure 1

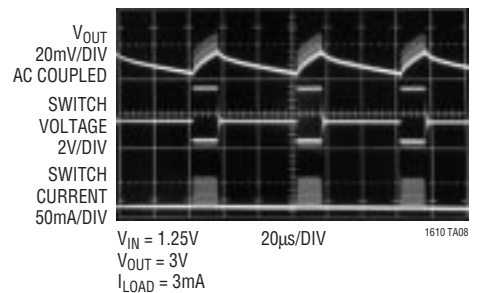

1610 TA08

PIN FUNCTIONS

V_C (Pin 1): Error Amplifier Output. Frequency compensation network must be connected to this pin, either internal (COMP pin) or external series RC to ground. 220kΩ/220pF typical value.

FB (Pin 2): Feedback Pin. Reference voltage is 1.23V. Connect resistive divider tap here. Minimize trace area at FB. Set V_{OUT} according to $V_{OUT} = 1.23V (1 + R1/R2)$.

SHDN (Pin 3): Shutdown. Ground this pin to turn off device. Tie to 1V or more to enable.

PGND (Pin 4): Power Ground. Tie directly to local ground plane.

SW (Pin 5): Switch Pin. Connect inductor/diode here. Minimize trace area at this pin to keep EMI down.

V_{IN} (Pin 6): Input Supply Pin. Must be locally bypassed.

GND (Pin 7): Signal Ground. Carries all device ground current except switch current. Tie to local ground plane.

COMP (Pin 8): Internal Compensation Network. Tie to V_C pin, or let float if external compensation is used. Output capacitor must be tantalum if COMP pin is used for compensation.

BLOCK DIAGRAM

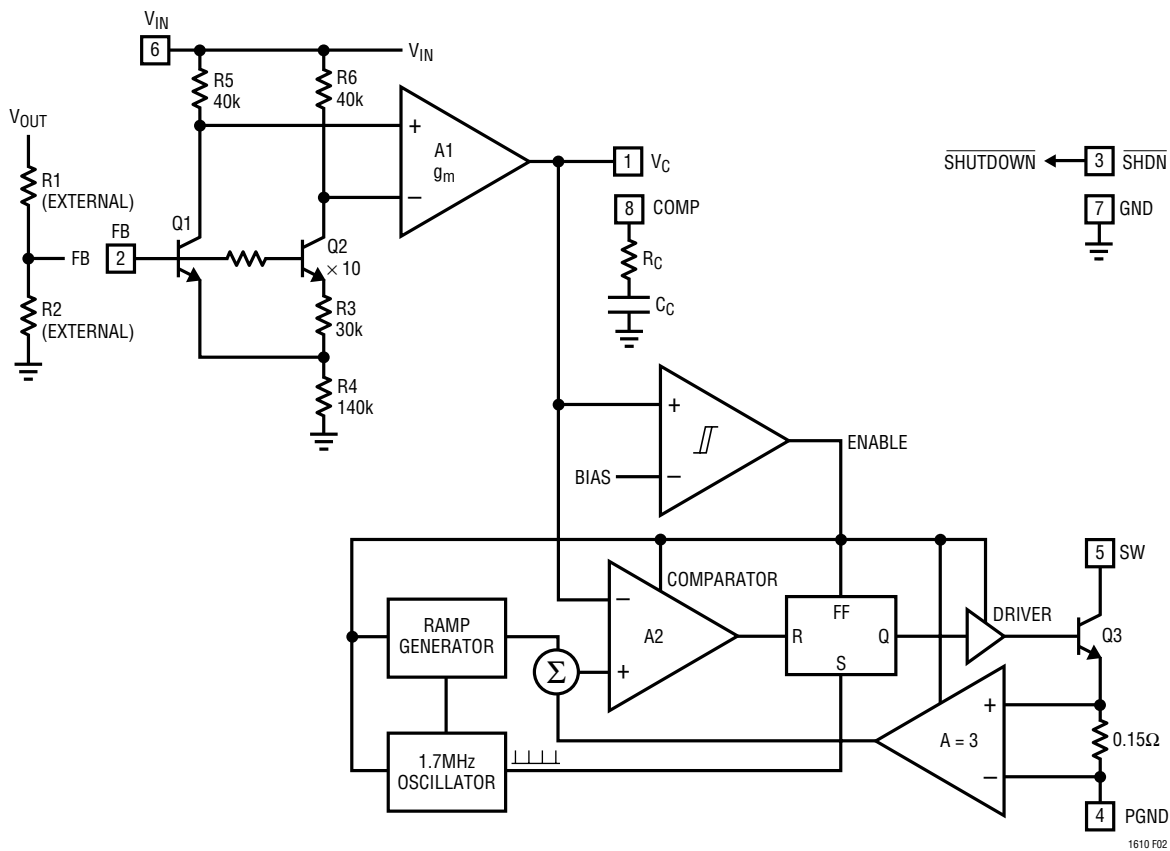

Figure 2. LT1610 Block Diagram

APPLICATIONS INFORMATION

OPERATION

The LT1610 combines a current mode, fixed frequency PWM architecture with Burst Mode micropower operation to maintain high efficiency at light loads. Operation can be best understood by referring to the block diagram in Figure 2. Q1 and Q2 form a bandgap reference core whose loop is closed around the output of the converter. When V_{IN} is 1V, the feedback voltage of 1.23V, along with an 70mV drop across R5 and R6, forward biases Q1 and Q2's base collector junctions to 300mV. Because this is not enough to saturate either transistor, FB can be at a higher voltage than V_{IN} . When there is no load, FB rises slightly above 1.23V, causing V_C (the error amplifier's output) to decrease. When V_C reaches the bias voltage on hysteretic comparator A1, A1's output goes low, turning off all circuitry except the input stage, error amplifier and low-battery detector. Total current consumption in this state is 30 μ A. As output loading causes the FB voltage to decrease, A1's output goes high, enabling the rest of the IC. Switch current is limited to approximately 100mA initially after A1's output goes high. If the load is light, the output voltage (and FB voltage) will increase until A1's output goes low, turning off the rest of the LT1610. Low frequency ripple voltage appears at the output. The ripple frequency is dependent on load current and output capacitance. This Burst Mode operation keeps the output regulated and reduces average current into the IC, resulting in high efficiency even at load currents of 1mA or less.

If the output load increases sufficiently, A1's output remains high, resulting in continuous operation. When the LT1610 is running continuously, peak switch current is controlled by V_C to regulate the output voltage. The switch is turned on at the beginning of each switch cycle. When the summation of a signal representing switch current and a ramp generator (introduced to avoid subharmonic oscillations at duty factors greater than 50%) exceeds the V_C signal, comparator A2 changes state, resetting the flip-flop and turning off the switch. Output voltage increases as switch current is increased. The output, attenuated by a resistor divider, appears at the FB pin, closing the overall loop. Frequency compensation is provided by either an external series RC network connected between the V_C pin and ground or the internal RC network on the COMP pin (Pin 8). The typical values for the internal RC are 50k and 50pF.

LAYOUT

Although the LT1610 is a relatively low current device, its high switching speed mandates careful attention to layout for optimum performance. For boost converters, follow the component placement indicated in Figure 3 for the best results. C2's negative terminal should be placed close to Pin 4 of the LT1610. Doing this reduces switching currents in the ground copper which keeps high frequency "spike" noise to a minimum. Tie the local ground into the system ground plane at one point only, using a few vias, to avoid introducing di/dt induced noise into the ground plane.

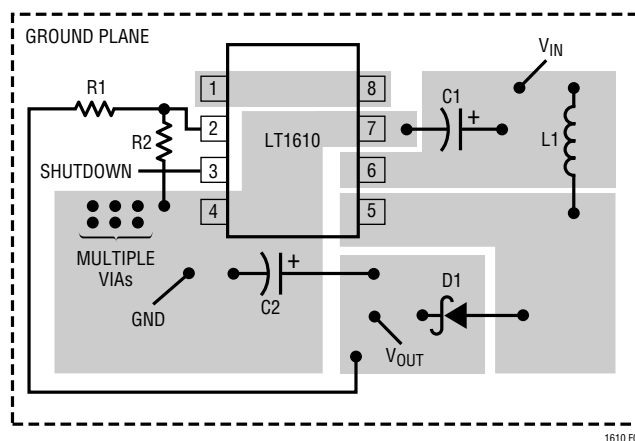

Figure 3. Recommended Component Placement for Boost Converter. Note Direct High Current Paths Using Wide PC Traces. Minimize Trace Area at Pin 1 (V_C) and Pin 2 (FB). Use Multiple Vias to Tie Pin 4 Copper to Ground Plane. Use Vias at One Location Only to Avoid Introducing Switching Currents into the Ground Plane

APPLICATIONS INFORMATION

A SEPIC (Single-Ended Primary Inductance Converter) schematic is shown in Figure 4. This converter topology produces a regulated output over an input voltage range

that spans (i.e., can be higher or lower than) the output. Recommended component placement for a SEPIC is shown in Figure 5.

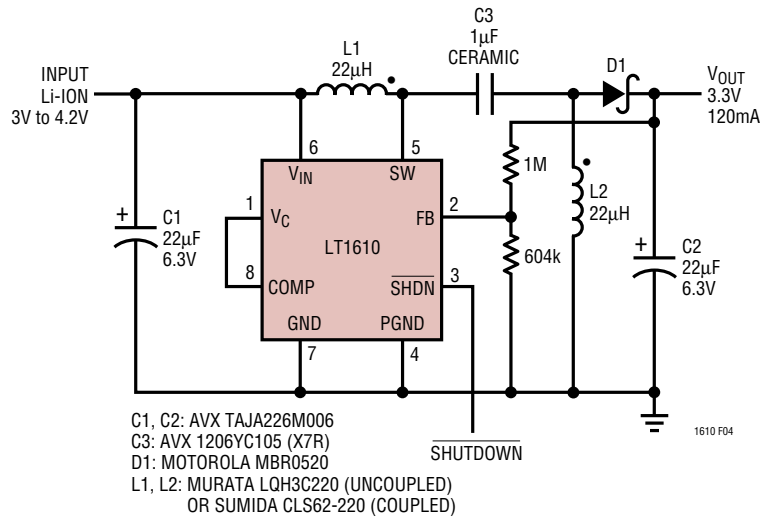

Figure 4. Li-Ion to 3.3V SEPIC DC/DC Converter

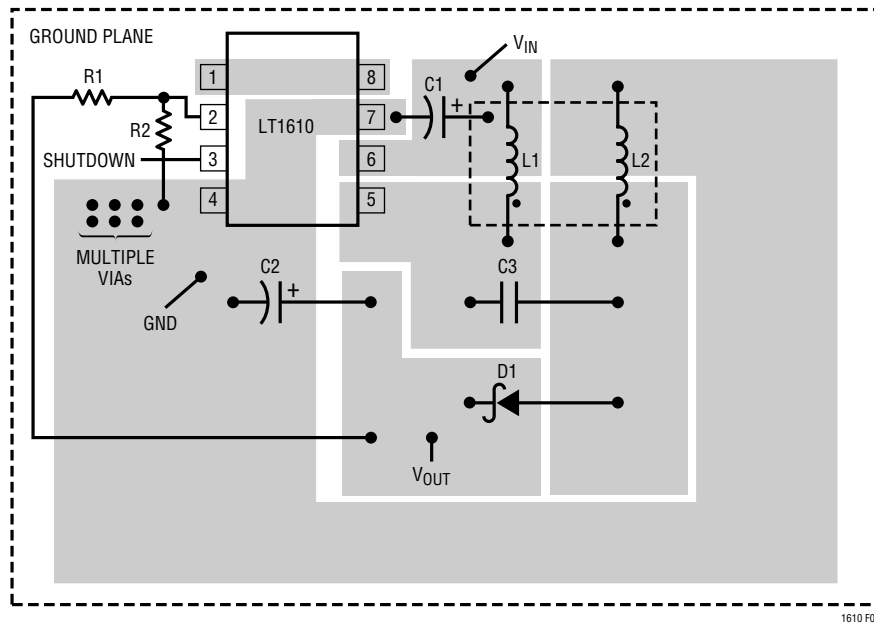

Figure 5. Recommended Component Placement for SEPIC

APPLICATIONS INFORMATION

COMPONENT SELECTION

Inductors

Inductors used with the LT1610 should have a saturation current rating (–30% of zero current inductance) of approximately 0.5A or greater. DCR should be 0.5Ω or less. The value of the inductor should be matched to the power requirements and operating voltages of the application. In most cases a value of 4.7μH or 10μH is suitable. The Murata LQH3C inductors specified throughout the data sheet are small and inexpensive, and are a good fit for the LT1610. Alternatives are the CD43 series from Sumida and the DO1608 series from Coilcraft. These inductors are slightly larger but will result in slightly higher circuit efficiency.

Chip inductors, although tempting to use because of their small size and low cost, generally do not have enough energy storage capacity or low enough DCR to be used successfully with the LT1610.

Diodes

The Motorola MBR0520 is a 0.5 amp, 20V Schottky diode. This is a good choice for nearly any LT1610 application, unless the output voltage or the circuit topology require a diode rated for higher reverse voltages. Motorola also offers the MBR0530 (30V) and MBR0540 (40V) versions. Most one-half amp and one amp Schottky diodes are suitable; these are available from many manufacturers. If you use a silicon diode, it must be an ultrafast recovery type. Efficiency will be lower due to the silicon diode's higher forward voltage drop.

Capacitors

The input capacitor must be placed physically close to the LT1610. ESR is not critical for the input. In most cases inexpensive tantalum can be used.

The choice of output capacitor is far more important. The quality of this capacitor is the greatest determinant of the output voltage ripple. The output capacitor performs two major functions. It must have enough capacitance to satisfy the load under transient conditions and it must shunt the AC component of the current coming through the diode from the inductor. The ripple on the output results when this AC current passes through the finite

impedance of the output capacitor. The capacitor should have low impedance at the 1.7MHz switching frequency of the LT1610. At this frequency, the impedance is usually dominated by the capacitor's equivalent series resistance (ESR). Choosing a capacitor with lower ESR will result in lower output ripple.

Perhaps the best way to decrease ripple is to add a 1μF ceramic capacitor in parallel with the bulk output capacitor. Ceramic capacitors have very low ESR and 1μF is enough capacitance to result in low impedance at the switching frequency. The low impedance can have a dramatic effect on output ripple voltage. To illustrate, examine Figure 6's circuit, a 4-cell to 5V/100mA SEPIC DC/DC converter. This design uses inexpensive aluminum electrolytic capacitors at input and output to keep cost down. Figure 7 details converter operation at a 100mA load, without ceramic capacitor C5. Note the 400mV spikes on V_{OUT} .

After C5 is installed, output ripple decreases by a factor of 8 to about 50mV_{P-P}. The addition of C5 also improves efficiency by 1 to 2 percent.

Low ESR and the required bulk output capacitance can be obtained using a single larger output capacitor. Larger tantalum capacitors, newer capacitor technologies (for example the POSCAP from Sanyo and SPCAP from Panasonic) or large value ceramic capacitors will reduce the output ripple. Note, however, that the stability of the circuit depends on both the value of the output capacitor and its ESR. When using low value capacitors or capacitors with very low ESR, circuit stability should be evaluated carefully, as described below.

Loop Compensation

The LT1610 is a current mode PWM switching regulator that achieves regulation with a linear control loop. The LT1610 provides the designer with two methods of compensating this loop. First, you can use an internal compensation network by tying the COMP pin to the V_C pin. This results in a very small solution and reduces the circuit's total part count. The second option is to tie a resistor R_C and a capacitor C_C in series from the V_C pin to ground. This allows optimization of the transient response for a wide variety of operating conditions and power components.

APPLICATIONS INFORMATION

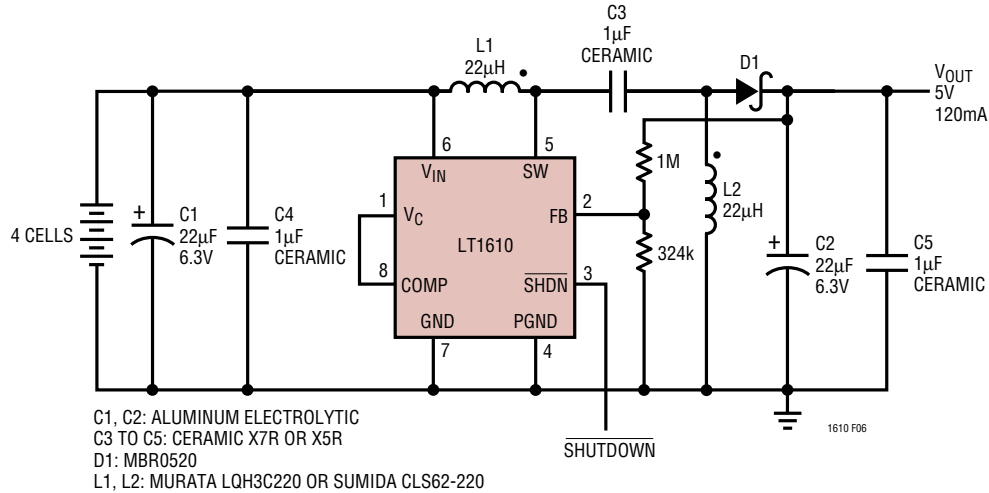

Figure 6. 4-Cell Alkaline to 5V/120mA SEPIC DC/DC Converter

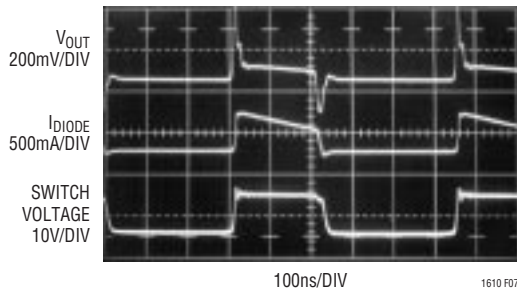

Figure 7. Switching Waveforms Without Ceramic Capacitor C5

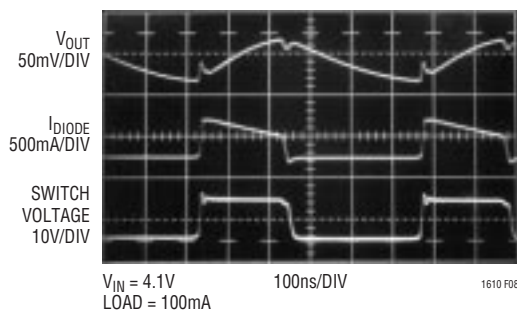

Figure 8. Switching Waveforms with Ceramic Capacitor C5. Note the 50mV/DIV Scale for VOUT

It is best to choose the compensation components empirically. Once the power components have been chosen (based on size, efficiency, cost and space requirements), a working circuit is built using conservative (or merely guessed) values of R_C and C_C . Then the response of the circuit is observed under a transient load, and the compen-

sation network is modified to achieve stable operation. Linear Technology’s Application Note 19 contains a detailed description of the method. A good starting point for the LT1610 is $C_C \sim 220\text{pF}$ and $R_C \sim 220\text{k}$.

All Ceramic, Low Profile Design

Large value ceramic capacitors that are suitable for use as the main output capacitor of an LT1610 regulator are now available. These capacitors have very low ESR and therefore offer very low output ripple in a small package. However, you should approach their use with some caution.

Ceramic capacitors are manufactured using a number of dielectrics, each with different behavior across temperature and applied voltage. Y5V is a common dielectric used for high value capacitors, but it can lose more than 80% of the original capacitance with applied voltage and extreme temperatures. The transient behavior and loop stability of the switching regulator depend on the value of the output capacitor, so you may not be able to afford this loss. Other dielectrics (X7R and X5R) result in more stable characteristics and are suitable for use as the output capacitor. The X7R type has better stability across temperature, whereas the X5R is less expensive and is available in higher values.

The second concern in using ceramic capacitors is that many switching regulators benefit from the ESR of the

APPLICATIONS INFORMATION

output capacitor because it introduces a zero in the regulator's loop gain. This zero may not be effective because the ceramic capacitor's ESR is very low. Most current mode switching regulators (including the LT1610) can easily be compensated without this zero. Any design should be tested for stability at the extremes of operating temperatures; this is particularly so of circuits that use ceramic output capacitors.

Figure 9 details a 2.5V to 5V boost converter. Transient response to a 5mA to 105mA load step is pictured in Figure 10. The "double trace" of V_{OUT} at 105mA load is due to the ESR of C2. This ESR aids stability. In Figure 11, C2 is replaced by a 10 μ F ceramic capacitor. Note the low phase margin; at higher input voltage, the converter may oscillate. After replacing the internal compensation network with an external 220pF/220k series RC, the transient response is shown in Figure 12. This is acceptable transient response.

Table 1

FIGURE	C2	COMPENSATION
10	AVX TAJA226M006 Tantalum	Internal
11	Taiyo Yuden JMK316BJ106	Internal
12	Taiyo Yuden JMK316BJ106	220pF/220k

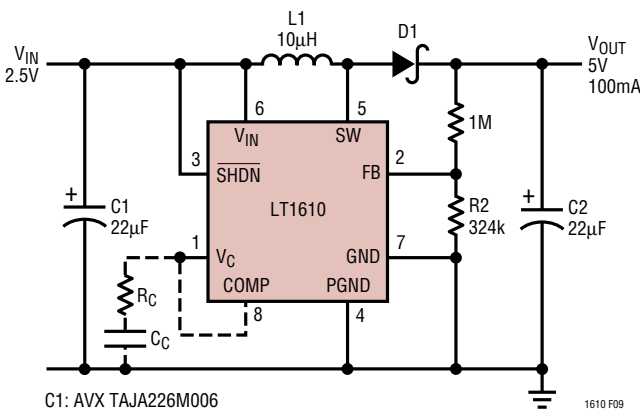

C1: AVX TAJA226M006
 C2: SEE TABLE
 D1: MOTOROLA MBR0520
 L1: MURATA LQH30100

Figure 9. 2.5V to 5V Boost Converter Can Operate with a Ceramic Output Capacitor as Long as Proper R_C and C_C are Used. Disconnect COMP Pin if External Compensation Components Are Used

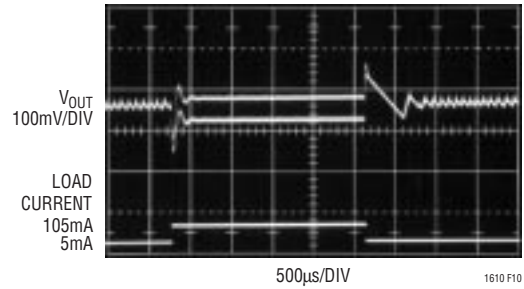

Figure 10. Tantalum Output Capacitor and Internal RC Compensation

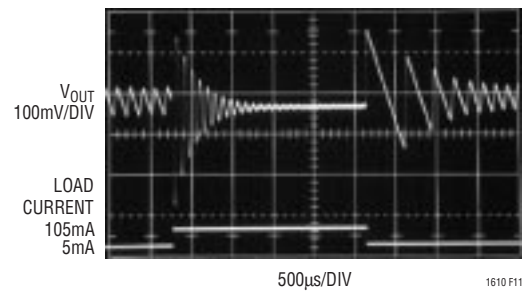

Figure 11. 10 μ F X5R-Type Ceramic Output Capacitor and Internal RC Compensation has Low Phase Margin

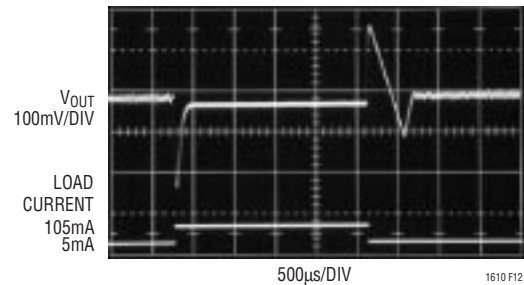
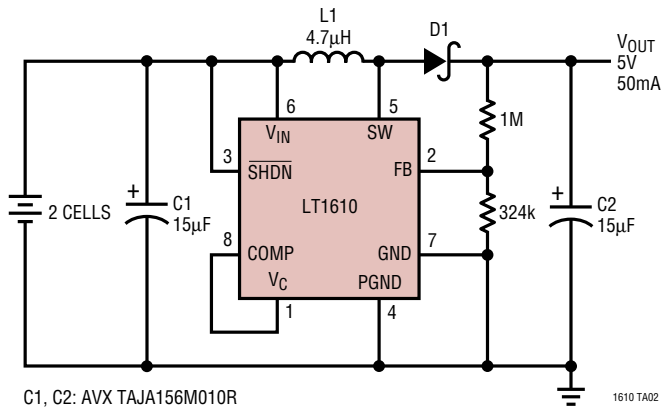

Figure 12. Ceramic Output Capacitor with 220pF/220k External Compensation has Adequate Phase Margin

TYPICAL APPLICATIONS

2-Cell to 5V Converter



- C1, C2: AVX TAJA156M010R
- D1: MOTOROLA MBR0520
- L1: SUMIDA CD43-4R7
- MURATA LQH1C4R7

1610 TA02

Efficiency

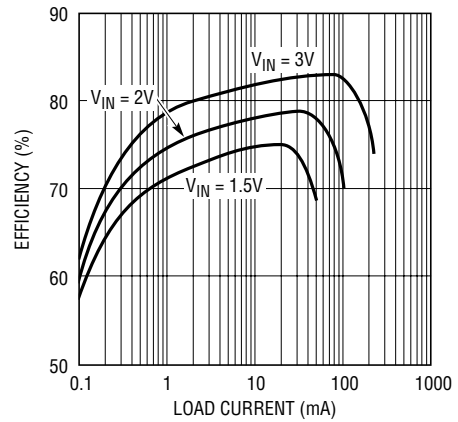

1610 TA03

2-Cell to 3.3V Converter

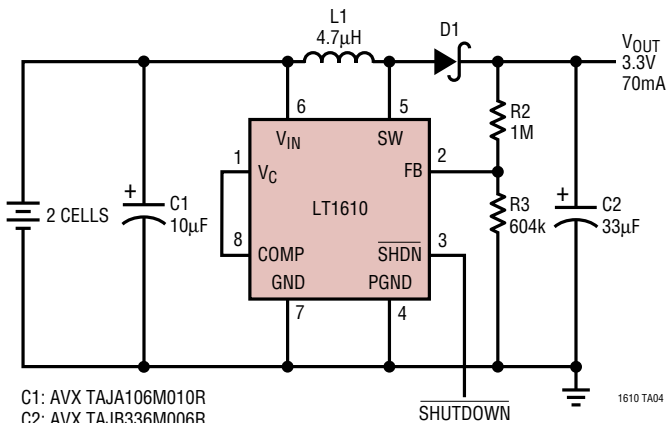

- C1: AVX TAJA106M010R
- C2: AVX TAJB336M006R
- D1: MBR0520
- L1: MURATA LQH3C4R7

1610 TA04

Efficiency

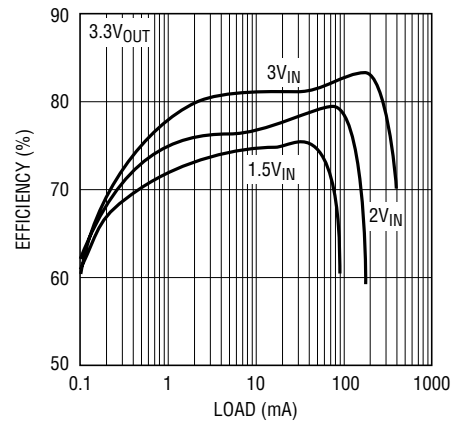

1610 TA05

5V to 12V/100mA Boost Converter

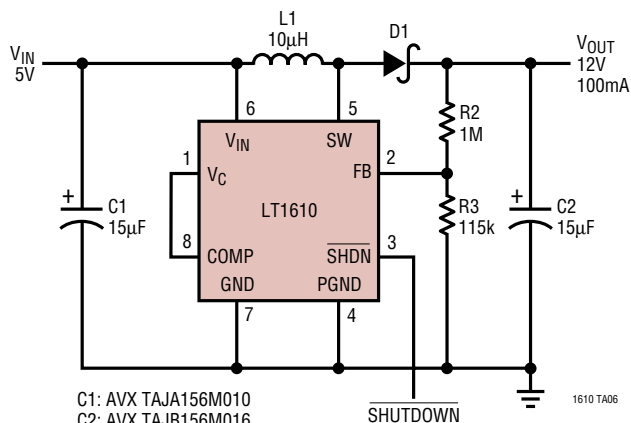

- C1: AVX TAJA156M010
- C2: AVX TAJB156M016
- D1: MOTOROLA MBR0520
- L1: MURATA LQH3C100M24

1610 TA06

Efficiency

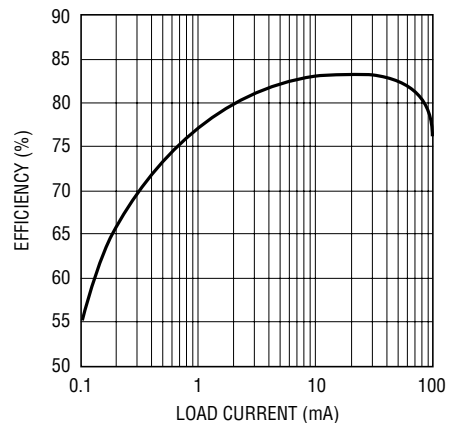

1610 TA07

TYPICAL APPLICATIONS

5V to 9V/150mA Boost Converter

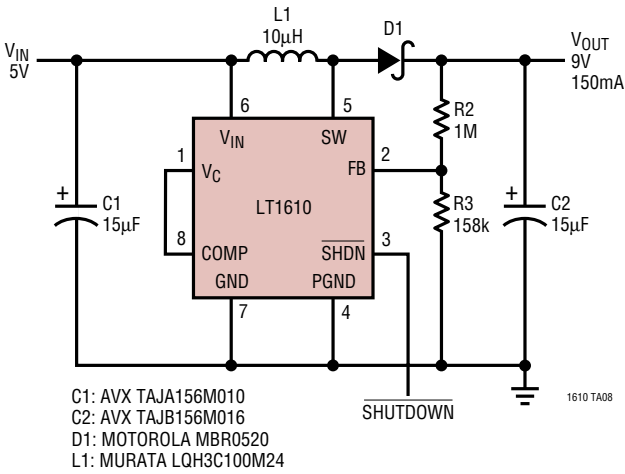

Efficiency

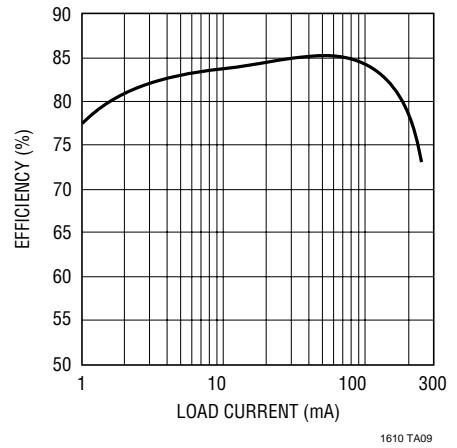

5V to 9V Boost Converter Transient Response

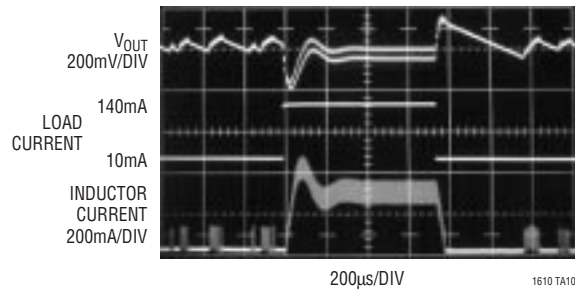

TYPICAL APPLICATIONS

3.3V TO 8V/70mA, -8V/5mA, 24V/5mA TFT LCD Bias Supply Uses All Ceramic Capacitors

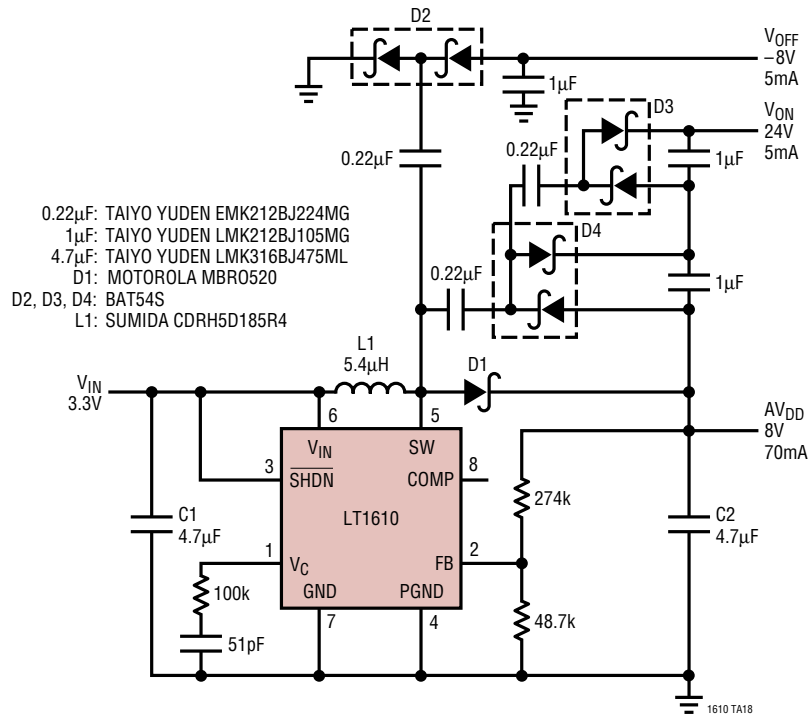

TFT LCD Bias Supply Transient Response

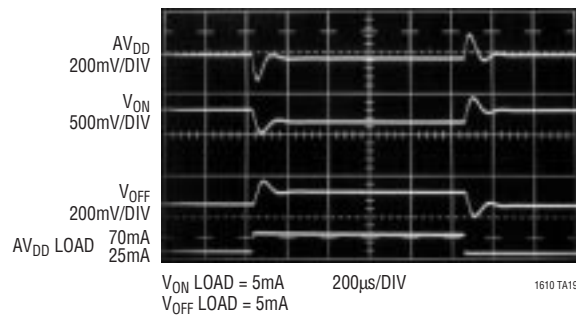

TYPICAL APPLICATIONS

Single Cell Super Cap Charger

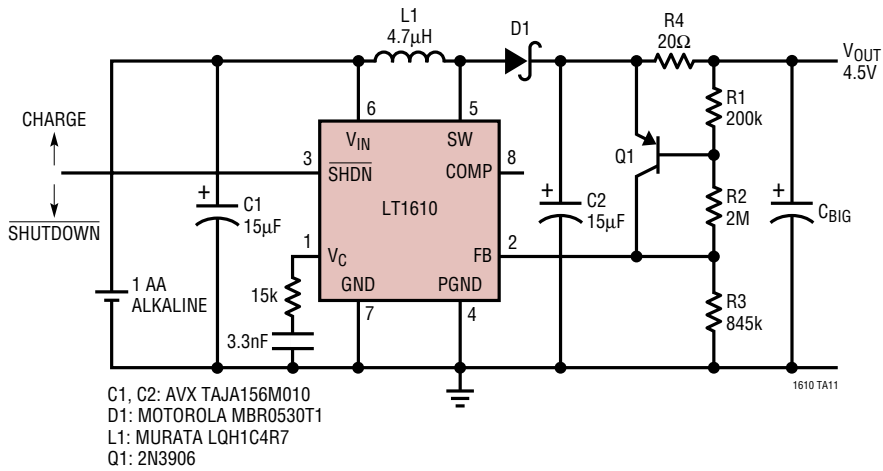

Super Cap Charger Output Current vs Output Voltage

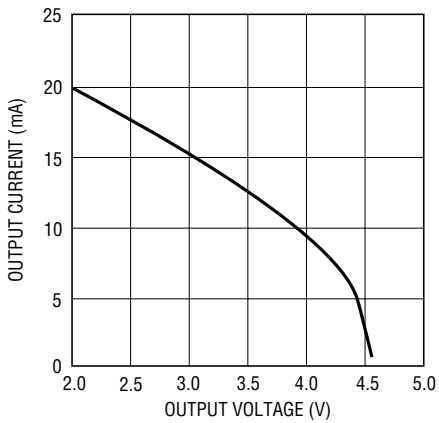

1610 TA12

Super Cap Charger Output Power vs Output Voltage

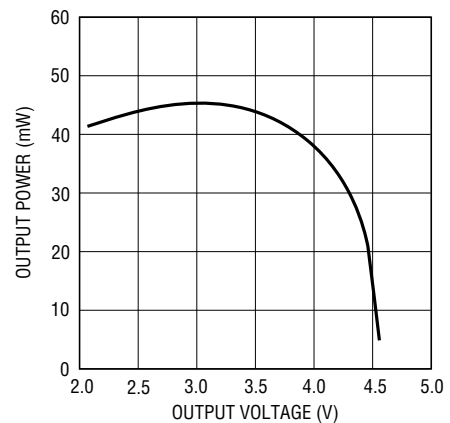

1610 TA13

PACKAGE DESCRIPTION Dimensions in inches (millimeters) unless otherwise noted.

MS8 Package
8-Lead Plastic MSOP
 (LTC DWG # 05-08-1660)

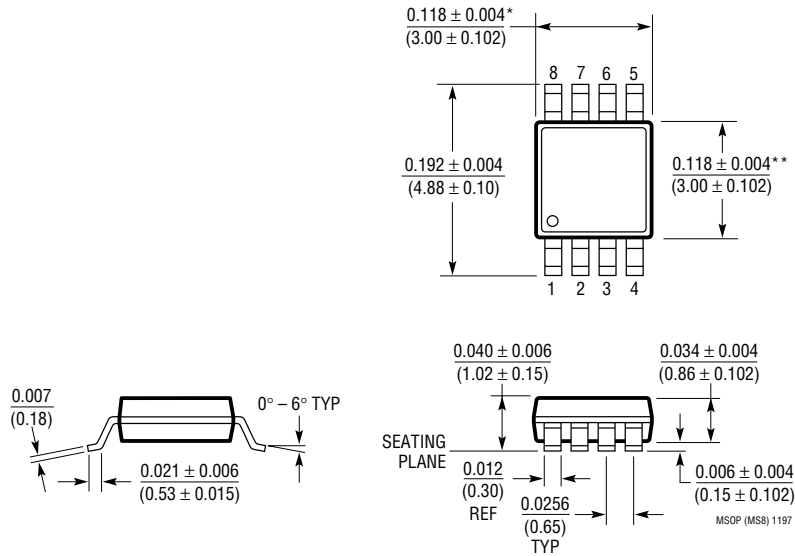

* DIMENSION DOES NOT INCLUDE MOLD FLASH, PROTRUSIONS OR GATE BURRS. MOLD FLASH, PROTRUSIONS OR GATE BURRS SHALL NOT EXCEED 0.006" (0.152mm) PER SIDE
 ** DIMENSION DOES NOT INCLUDE INTERLEAD FLASH OR PROTRUSIONS. INTERLEAD FLASH OR PROTRUSIONS SHALL NOT EXCEED 0.006" (0.152mm) PER SIDE

S8 Package
8-Lead Plastic Small Outline (Narrow 0.150)
 (LTC DWG # 05-08-1610)

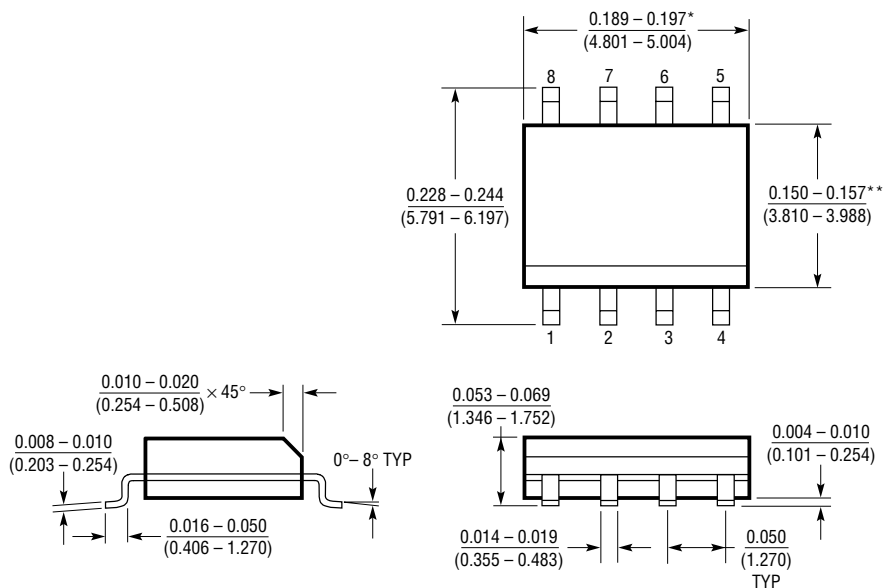

* DIMENSION DOES NOT INCLUDE MOLD FLASH. MOLD FLASH SHALL NOT EXCEED 0.006" (0.152mm) PER SIDE
 ** DIMENSION DOES NOT INCLUDE INTERLEAD FLASH. INTERLEAD FLASH SHALL NOT EXCEED 0.010" (0.254mm) PER SIDE

S08 0996

TYPICAL APPLICATIONS

Li-Ion to 3.3V SEPIC DC/DC Converter

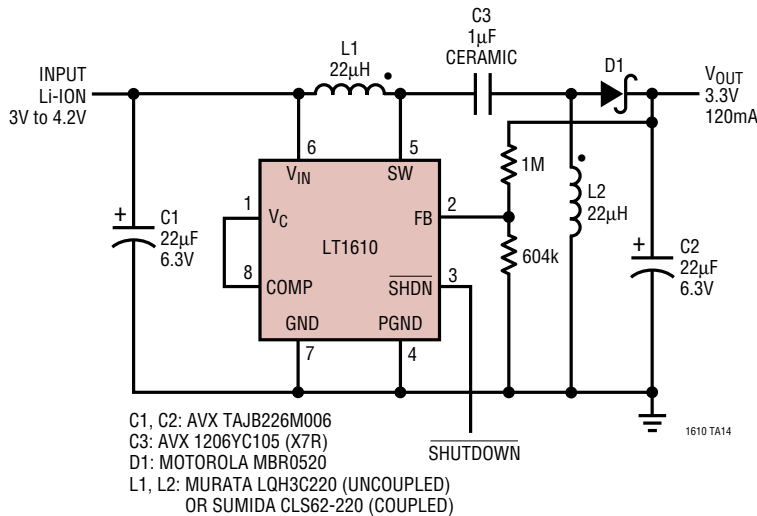

Efficiency

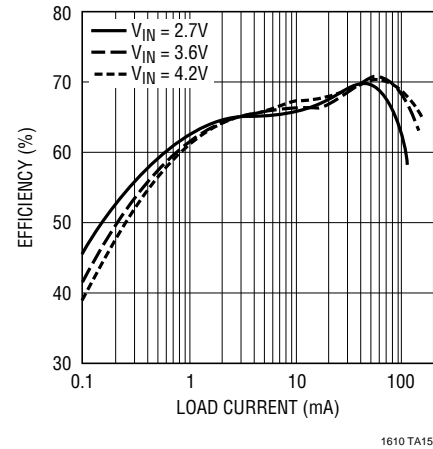

4-Cell to 5V/120mA SEPIC DC/DC Converter

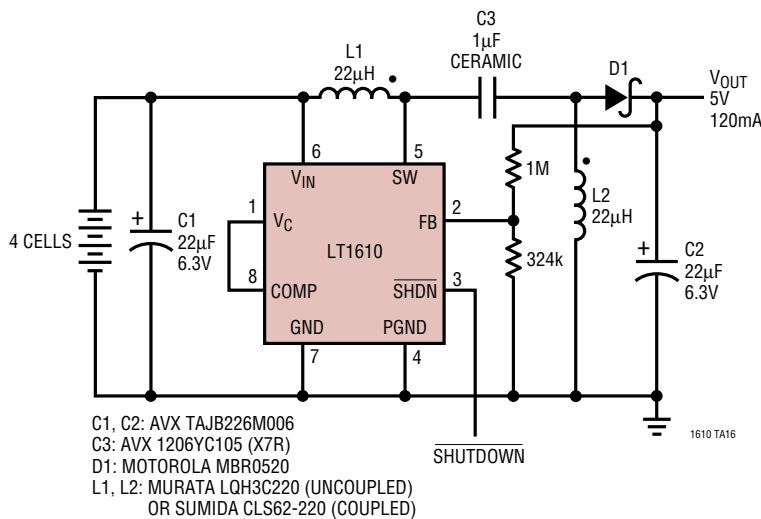

4-Cell to 5V Efficiency

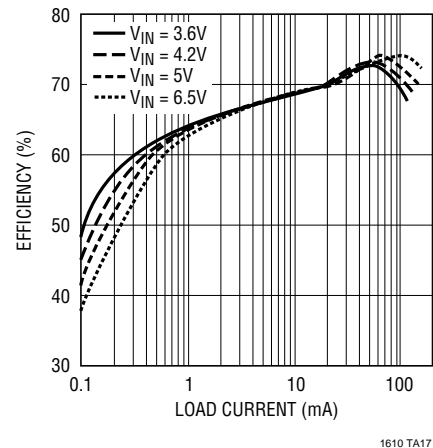

RELATED PARTS

PART NUMBER	DESCRIPTION	COMMENTS
LTC®1474	Micropower Step-Down DC/DC Converter	94% Efficiency, 10µA I _Q , 9V to 5V at 250mA
LT1307	Single Cell Micropower 600kHz PWM DC/DC Converter	3.3V at 75mA from 1 Cell, MSOP Package
LTC1440/1/2	Ultralow Power Single/Dual Comparators with Reference	2.8µA I _Q , Adjustable Hysteresis
LTC1502-3.3	Single Cell to 3.3V Regulated Charge Pump	40µA I _Q , No Inductors, 3.3V at 10mA from 1V Input
LT1521	Micropower Low Dropout Linear Regulator	500mV Dropout, 300mA Current, 12µA I _Q
LT1611	Inverting 1.4MHz DC/DC Converter	5V to -5V at 150mA, Tiny SOT-23 Package
LT1613	Step-Up 1.4MHz DC/DC Converter	3.3V to 5V at 200mA, Tiny SOT-23 Package
LTC1682	Doubler Charge Pump with Low Noise Linear Regulator	Fixed 3.3V and 5V Outputs, 1.8V to 4.4V Input Range, 50mA Output