

5-Bit VID Single-Phase Voltage Regulator with Current Monitor for IMVP-6+ Santa Rosa GPU Core

The ISL6263B IC is a Single-Phase Synchronous-Buck PWM voltage regulator featuring Intersil's Robust Ripple Regulator (R³) Technology™. The ISL6263B is an implementation of the Intel® Mobile Voltage Positioning (IMVP) protocol for GPU Render Engine core power. Integrated current monitor, droop amplifier, MOSFET drivers and bootstrap diode result in smaller implementation area and lower component cost.

Intersil's R³ Technology™ combines the best features of both fixed-frequency PWM and hysteretic PWM, delivering excellent light-load efficiency and superior load transient response by commanding variable switching frequency during the transitory event. For maximum conversion efficiency, the ISL6263B automatically enters diode-emulation mode (DEM) should the inductor current attempt to flow negative. DEM is highly configurable and easy to set-up. A PWM filter can be enabled that prevents the switching frequency from entering the audible spectrum as a result of extremely light load while in DEM.

The Render core voltage can be dynamically programmed from 0.41200V to 1.28750V by the five VID input pins without requiring sequential stepping of the VID states. The ISL6263B requires only one capacitor for both the soft-start slew-rate and the dynamic VID slew-rate by internally connecting the SOFT pin to the appropriate current source. Processor socket Kelvin sensing is accomplished with an integrated unity-gain true differential amplifier.

Ordering Information

PART NUMBER (Notes 2, 3)	PART MARKING	TEMP (°C)	PACKAGE (Pb-Free)	PKG. DWG. #
ISL6263BHRZ	ISL6263 BHRZ	-10 to +100	32 Ld 5x5 QFN	L32.5x5
ISL6263BHRZ-T (Note 1)	ISL6263 BHRZ	-10 to +100	32 Ld 5x5 QFN Tape and Reel	L32.5x5

NOTES:

- Please refer to [TB347](#) for details on reel specifications.
- These Intersil Pb-free plastic packaged products employ special Pb-free material sets, molding compounds/die attach materials, and 100% matte tin plate plus anneal (e3 termination finish, which is RoHS compliant and compatible with both SnPb and Pb-free soldering operations). Intersil Pb-free products are MSL classified at Pb-free peak reflow temperatures that meet or exceed the Pb-free requirements of IPC/JEDEC J STD-020.
- For Moisture Sensitivity Level (MSL), please see device information page for [ISL6263B](#). For more information on MSL please see techbrief [TB363](#).

Features

- Precision single-phase core voltage regulator
 - 0.5% system accuracy 0°C to +100°C
 - Differential remote GPU die voltage sensing
 - Differential droop voltage sensing
- Real-time GPU current monitor output
- Applications up to 25A
- Input voltage range: +5.0V to +25.0V
- Programmable PWM frequency: 200kHz to 500kHz
- Pre-biased output start-up capability
- 5-bit voltage identification input (VID)
 - 1.28750V to 0.41200V
 - 25.75mV steps
 - Sequential or non-sequential VID change on-the-fly
- Configurable PWM modes
 - forced continuous conduction mode
 - automatic entry and exit of diode emulation mode
 - selectable audible frequency PWM filter
- Integrated MOSFET drivers and bootstrap diode
- Choice of current sensing schemes
 - Lossless inductor DCR current sensing
 - Precision resistive current sensing
- Overvoltage, undervoltage and overcurrent protection
- Pb-free (RoHS compliant)

Pinout

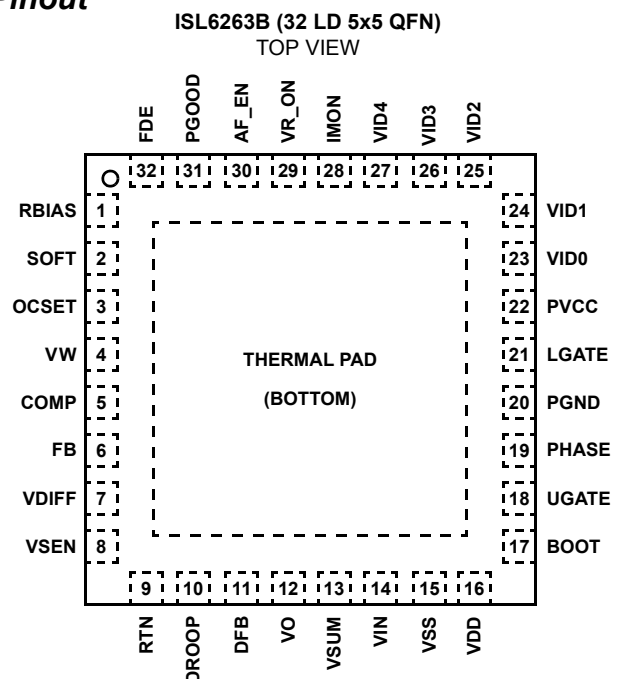

Block Diagram

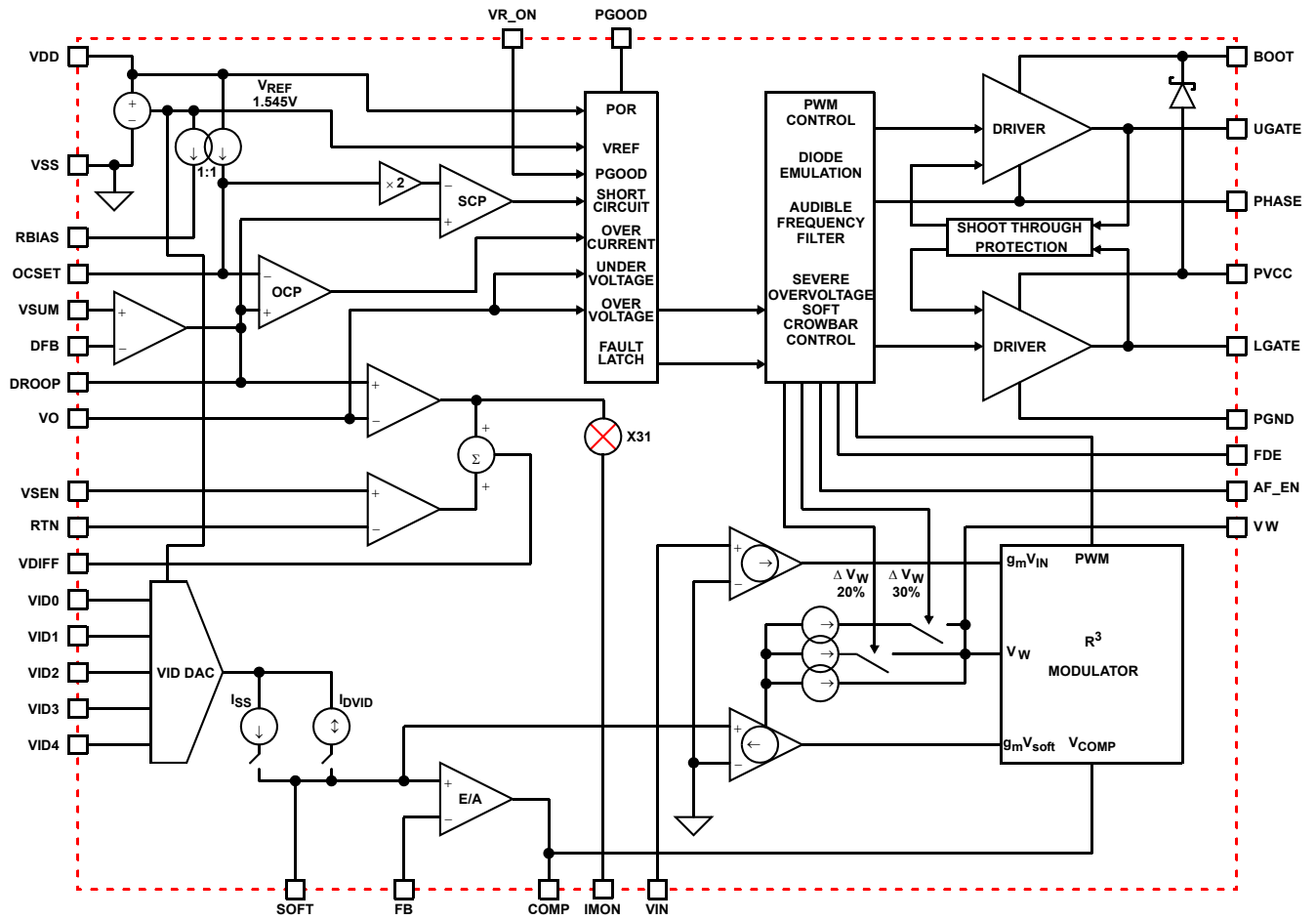

FIGURE 1. SIMPLIFIED FUNCTIONAL BLOCK DIAGRAM OF THE ISL6263B

Simplified Application Circuit for DCR Current Sensing

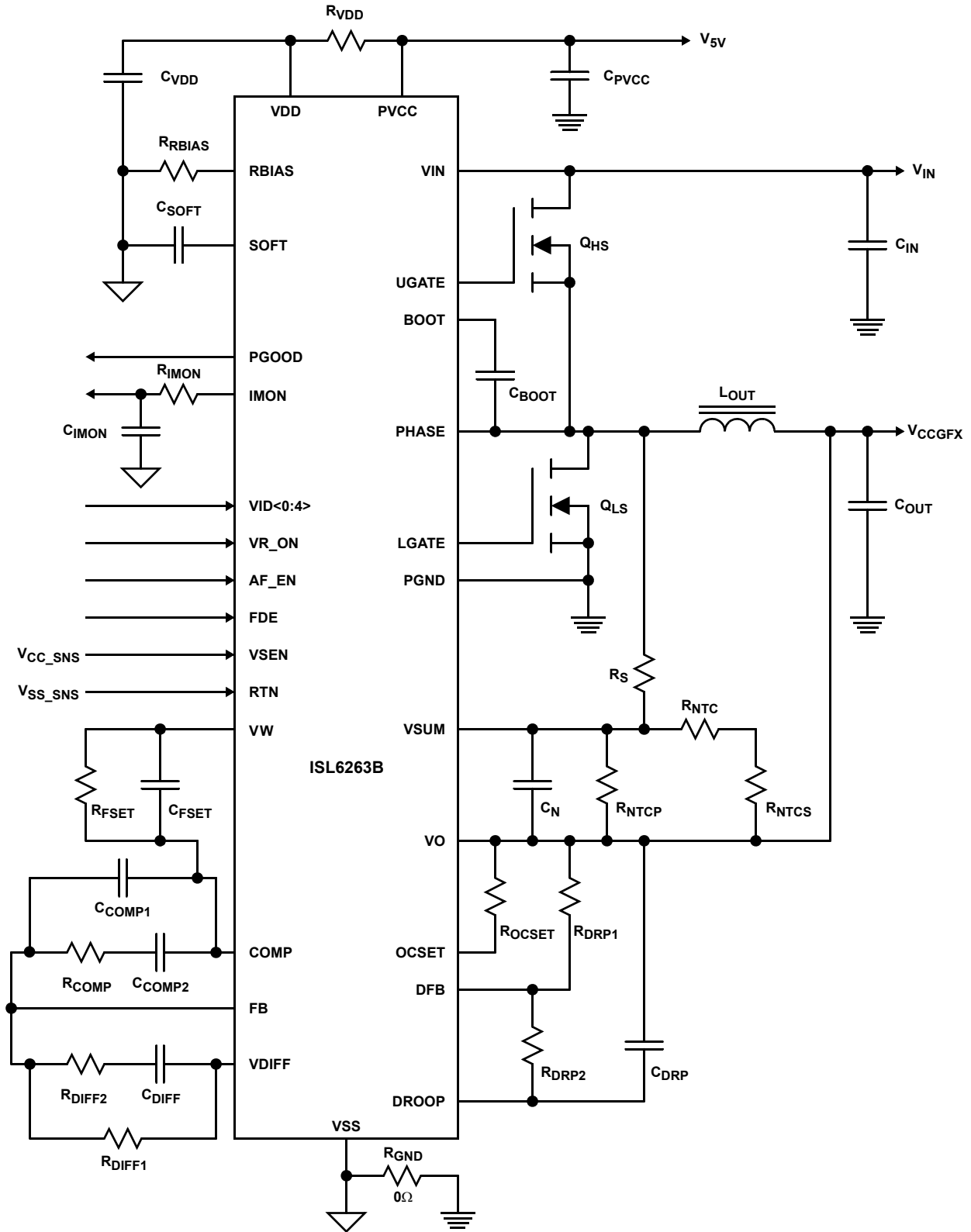

FIGURE 2. ISL6263B GPU RENDER-CORE VOLTAGE REGULATOR SOLUTION WITH DCR CURRENT SENSING

Simplified Application Circuit for Resistive Current Sensing

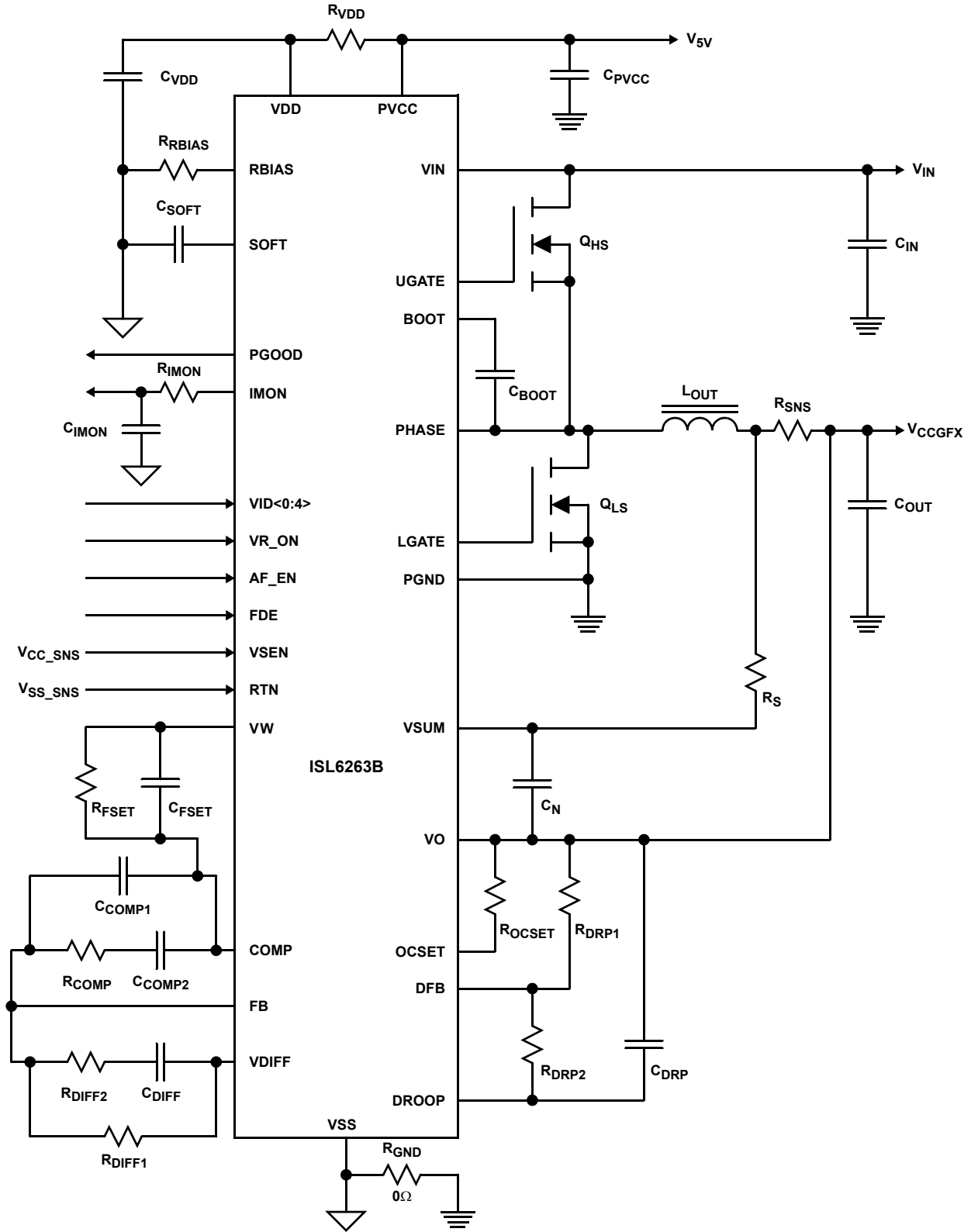

FIGURE 3. ISL6263B GPU RENDER-CORE VOLTAGE REGULATOR SOLUTION WITH RESISTIVE CURRENT SENSING

Absolute Voltage Ratings

VIN to VSS	-0.3V to +28V
VDD to VSS	-0.3V to +7.0V
PVCC to PGND	-0.3V to +7.0V
VSS to PGND	-0.3V to +0.3V
PHASE to VSS	(DC) -0.3V to +28V ($<100\text{ns}$ Pulse Width, $10\mu\text{J}$) -5.0V
BOOT to PHASE	-0.3V to +7.0V
BOOT to VSS or PGND	-0.3V to +33V
UGATE	(DC) -0.3V to PHASE, BOOT +0.3V ($<200\text{ns}$ Pulse Width, $20\mu\text{J}$) -4.0V
LGATE	(DC) -0.3V to PGND, PVCC +0.3V ($<100\text{ns}$ Pulse Width, $4\mu\text{J}$) -2.0V
ALL Other Pins	-0.3V to VSS, VDD +0.3V

Thermal Information

Thermal Resistance (Typical, Notes 4, 5)	θ_{JA} ($^{\circ}\text{C}/\text{W}$)	θ_{JC} ($^{\circ}\text{C}/\text{W}$)
QFN Package	35	6
Junction Temperature Range	-55 $^{\circ}\text{C}$ to +150 $^{\circ}\text{C}$	
Operating Temperature Range	-10 $^{\circ}\text{C}$ to +100 $^{\circ}\text{C}$	
Storage Temperature	-65 $^{\circ}\text{C}$ to +150 $^{\circ}\text{C}$	
Pb-free reflow profile	see link below http://www.intersil.com/pbfree/Pb-FreeReflow.asp	

Recommended Operating Conditions

Ambient Temperature Range	-10 $^{\circ}\text{C}$ to +100 $^{\circ}\text{C}$
VIN to VSS	+5V to +25V
VDD to VSS	+5V \pm 5%
PVCC to PGND	+5V \pm 5%
FDE to VSS	0V to +3.3V

CAUTION: Do not operate at or near the maximum ratings listed for extended periods of time. Exposure to such conditions may adversely impact product reliability and result in failures not covered by warranty.

NOTES:

- θ_{JA} is measured in free air with the component mounted on a high effective thermal conductivity test board with "direct attach" features. See Tech Brief TB379.
- For θ_{JC} , the "case temp" location is the center of the exposed metal pad on the package underside.

Electrical Specifications These specifications apply for $T_A = -10^{\circ}\text{C}$ to +100 $^{\circ}\text{C}$, unless otherwise stated. All typical specifications $T_A = +25^{\circ}\text{C}$, $V_{DD} = 5\text{V}$, $PVCC = 5\text{V}$. **Boldface limits apply over the operating temperature range, -10 $^{\circ}\text{C}$ to +100 $^{\circ}\text{C}$.**

PARAMETER	SYMBOL	TEST CONDITIONS	MIN (Note 6)	TYP	MAX (Note 6)	UNITS
VIN						
VIN Input Resistance	R_{VIN}	$VR_{ON} = 3.3\text{V}$		1.0		$\text{M}\Omega$
VIN Shutdown Current	I_{VIN_SHDN}	$VR_{ON} = 0\text{V}$, $V_{IN} = 25\text{V}$			1.0	μA
VDD and PVCC						
VDD Input Bias Current	I_{VDD}	$VR_{ON} = 3.3\text{V}$		2.7	3.3	mA
VDD Shutdown Current	I_{VDD_SHDN}	$VR_{ON} = 0\text{V}$, $V_{DD} = 5.0\text{V}$			1.0	μA
VDD POR THRESHOLD						
Rising VDD POR Threshold Voltage	V_{VDD_THR}			4.35	4.50	V
Falling VDD POR Threshold Voltage	V_{VDD_THF}		3.85	4.10		V
REGULATION						
Output Voltage Range	V_{GFX_MAX}	VID<4:0> = 00000		1.28750		V
	V_{GFX_MIN}	VID<4:0> = 11111		0.41200		V
VID Voltage Step		VID<4:0> = 00000 to 11110 (1.28750V to 0.51500V)		25.75		mV/step
		VID<4:0> = 11110 to 11111 (0.51500V to 0.41200V)		103		mV
System Accuracy		VID = 1.28750V to 0.74675V $T_A = 0^{\circ}\text{C}$ to +100 $^{\circ}\text{C}$	-0.5		0.5	%
		VID = 0.72100V to 0.51500V $T_A = 0^{\circ}\text{C}$ to +100 $^{\circ}\text{C}$	-1.0		1.0	%
		VID = 0.41200 $T_A = 0^{\circ}\text{C}$ to +100 $^{\circ}\text{C}$	-3.0		3.0	%

ISL6263B

Electrical Specifications These specifications apply for $T_A = -10^\circ\text{C}$ to $+100^\circ\text{C}$, unless otherwise stated. All typical specifications $T_A = +25^\circ\text{C}$, $V_{DD} = 5\text{V}$, $PV_{CC} = 5\text{V}$. **Boldface limits apply over the operating temperature range, -10°C to $+100^\circ\text{C}$. (Continued)**

PARAMETER	SYMBOL	TEST CONDITIONS	MIN (Note 6)	TYP	MAX (Note 6)	UNITS
PWM						
Nominal Frequency	f_{SW}	$R_{FSET} = 7\text{k}\Omega$, $V_{COMP} = 2\text{V}$	318	333	348	kHz
Frequency Range			200		500	kHz
Audio Filter Frequency	F_{AF}			28		kHz
AMPLIFIERS						
Error Amplifier DC Gain (Note 7)	A_{V0}			90		dB
Error Amplifier Gain-Bandwidth Product (Note 7)	GBW	$C_L = 20\text{pF}$		18		MHz
Error Amp Slew Rate (Note 7)	SR	$C_L = 20\text{pF}$		5		V/ μs
FB Input Bias Current	I_{FB}	$V_{FB} = 1.2875\text{V}$		10	150	nA
Droop Amplifier Offset	V_{DROOP_OFS}		-0.3		0.3	mV
RBIAS Voltage	V_{RBIAS}	$R_{RBIAS} = 150\text{k}\Omega$	1.495	1.515	1.535	V
SOFT-START CURRENT						
Soft-Start Current	I_{SS}		-47	-42	-37	μA
Soft Dynamic VID Current	I_{DVID}	$ \text{SOFT} - \text{REF} > 100\text{mV}$	± 180	± 205	± 230	μA
CURRENT MONITOR						
Current Monitor Output Voltage Range	V_{IMON}	$V_{DROOP} - V_O = 40\text{mV}$	1.22	1.24	1.26	V
		$V_{DROOP} - V_O = 10\text{mV}$	0.285	0.310	0.335	V
Current Monitor Maximum Output Voltage	$V_{IMONMAX}$		3.1	3.4		V
Current Monitor Maximum Current Sinking Capability			$V_{IMON}/250\Omega$	$V_{IMON}/180\Omega$	$V_{IMON}/130\Omega$	A
Current Monitor Sourcing Current	I_{SC_IMON}	$V_{DROOP} - V_O = 40\text{mV}$	2.0			mA
Current Monitor Sinking Current	I_{SK_IMON}	$V_{DROOP} - V_O = 40\text{mV}$	2.0			mA
Current Monitor Impedance (Note 7)		$I_{IMON} \leq I_{SK_IMON}$, $I_{IMON} \leq I_{SC_IMON}$		7		Ω
GATE DRIVER						
UGATE Source Resistance (Note 7)	R_{UGSRC}	500mA Source Current		1.0	1.5	Ω
UGATE Source Current (Note 7)	I_{UGSRC}	$V_{UGATE_PHASE} = 2.5\text{V}$		2.0		A
UGATE Sink Resistance (Note 7)	R_{UGSNK}	500mA Sink Current		1.0	1.5	Ω
UGATE Sink Current (Note 3)	I_{UGSNK}	$V_{UGATE_PHASE} = 2.5\text{V}$		2.0		A
LGATE Source Resistance (Note 7)	$R_{LG SRC}$	500mA Source Current		1.0	1.5	Ω
LGATE Source Current (Note 7)	$I_{LG SRC}$	$V_{LGATE_PGND} = 2.5\text{V}$		2.0		A
LGATE Sink Resistance (Note 7)	$R_{LG SNK}$	500mA Sink Current		0.5	0.9	Ω
LGATE Sink Current (Note 7)	$I_{LG SNK}$	$V_{LGATE_PGND} = 2.5\text{V}$		4.0		A
UGATE Pull-Down Resistor	R_{PD}			1.1		k Ω
UGATE Turn-On Propagation Delay	t_{PDRU}	$PV_{CC} = 5\text{V}$, UGATE open	20	30	44	ns
LGATE Turn-On Propagation Delay	t_{PDRL}	$PV_{CC} = 5\text{V}$, LGATE open	7	15	30	ns
BOOTSTRAP DIODE						
Forward Voltage	V_F	$PV_{CC} = 5\text{V}$, $I_F = 10\text{mA}$	0.56	0.69	0.76	V
Reverse Leakage	I_R	$V_R = 16\text{V}$			5.0	μA

ISL6263B

Electrical Specifications These specifications apply for $T_A = -10^\circ\text{C}$ to $+100^\circ\text{C}$, unless otherwise stated. All typical specifications $T_A = +25^\circ\text{C}$, $V_{DD} = 5\text{V}$, $PVCC = 5\text{V}$. **Boldface limits apply over the operating temperature range, -10°C to $+100^\circ\text{C}$. (Continued)**

PARAMETER	SYMBOL	TEST CONDITIONS	MIN (Note 6)	TYP	MAX (Note 6)	UNITS
POWER GOOD and PROTECTION MONITOR						
PGOOD Low Voltage	V_{PGOOD}	$I_{PGOOD} = 4\text{mA}$		0.11	0.40	V
PGOOD Leakage Current	I_{PGOOD}	$V_{PGOOD} = 3.3\text{V}$	-1.0		1.0	μA
Overvoltage Threshold (V_O - V_{SOFT})	V_{OVP}	V_O rising above $V_{SOFT} > 1\text{ms}$	155	195	235	mV
Severe Overvoltage Threshold	V_{OVPS}	V_O rising above 1.55V reference $> 0.5\mu\text{s}$	1.525	1.550	1.575	V
OCSET Reference Current	I_{OCSET}	$R_{RBIAS} = 150\text{k}\Omega$	9.9	10.1	10.3	μA
OCSET Voltage Threshold Offset	V_{OCSET_OFS}	V_{DROOP} rising above $V_{OCSET} > 120\mu\text{s}$	-3		3	mV
Undervoltage Threshold (V_{SOFT} - V_O)	V_{UVF}	V_O falling below V_{SOFT} for $> 1\text{ms}$	-360	-300	-240	mV
CONTROL INPUTS						
VR_ON Input Low	V_{VR_ONL}				1	V
VR_ON Input High	V_{VR_ONH}		2.3			V
AF_EN Input Low	V_{AF_ENL}				1	V
AF_EN Input High	V_{AF_ENH}		2.3			V
VR_ON Leakage	I_{VR_ONL}	$V_{VR_ON} = 0\text{V}$	-1.0	0		μA
	I_{VR_ONH}	$V_{VR_ON} = 3.3\text{V}$		0	1.0	μA
AF_EN Leakage	I_{AF_ENL}	$V_{AF_EN} = 0\text{V}$	-1.0	0		μA
	I_{AF_ENH}	$V_{AF_EN} = 3.3\text{V}$		0.45	1.0	μA
VID<4:0> Input Low	V_{VIDL}				0.4	V
VID<4:0> Input High	V_{VIDH}		0.7			V
FDE Input Low	V_{FDEL}				0.3	V
FDE Input High	V_{FDEH}		0.7			V
VID<4:0> Leakage	I_{VIDL}	$V_{VID} = 0\text{V}$	-1.0	0		μA
	I_{VIDH}	$V_{VID} = 1.0\text{V}$		0.45	1.0	μA
FDE Leakage	I_{FDEL}	$V_{FDE} = 0\text{V}$	-1.0	0		μA
	I_{FDEH}	$V_{FDE} = 1.0\text{V}$		0.45	1.0	μA

NOTE:

6. Parameters with MIN and/or MAX limits are 100% tested at $+25^\circ\text{C}$, unless otherwise specified. Temperature limits established by characterization and are not production tested.
7. Limits established by characterization and are not production tested.

Functional Pin Descriptions

RBIAS (Pin 1) - Sets the internal 10 μ A current reference. Connect a 150k Ω \pm 1% resistor from RBIAS to VSS.

SOFT (Pin 2) - Sets the output voltage slew-rate. Connect an X5R or X7R ceramic capacitor from SOFT to VSS. The SOFT pin is the non-inverting input of the error amplifier.

OCSET (Pin 3) - Sets the overcurrent threshold. Connect a resistor from OCSET to VO.

VW (Pin 4) - Sets the static PWM switching frequency in continuous conduction mode. Connect a resistor from VW to COMP.

COMP (Pin 5) - Connects to the output of the control loop error amplifier.

FB (Pin 6) - Connects to the inverting input of the control loop error amplifier.

VDIFF (Pin 7) - Connects to the output of the VDIFF differential-summing amplifier.

VSEN (Pin 8) - This is the V_{CC_SNS} input of the processor socket Kelvin connection. Connects internally to one of two non-inverting inputs of the VDIFF differential-summing amplifier.

RTN (Pin 9) - This is the V_{SS_SNS} input of the processor socket Kelvin connection. Connects internally to one of two inverting inputs of the VDIFF differential-summing amplifier.

DROOP (Pin 10) - Connects to the output of the droop differential amplifier and to one of two non-inverting inputs of the VDIFF differential-summing amplifier.

DFB (Pin 11) - This is the feedback of the droop amplifier. Connects internally to the inverting input of the droop differential amplifier.

VO (Pin 12) - Connects to one of two inverting inputs of the VDIFF differential-summing amplifier.

VSUM (Pin 13) - Connects to the non-inverting input of the droop differential amplifier.

VIN (Pin 14) - Connects to the R³ PWM modulator providing input voltage feed-forward. For optimum input voltage transient response, connect near the drain of the high-side MOSFETs.

VSS (Pin 15) - Analog ground.

VDD (Pin 16) - Input power supply for the IC. Connect to +5VDC and decouple with at least a 1 μ F MLCC capacitor from the VDD pin to the VSS pin.

BOOT (Pin 17) - Input power supply for the high-side MOSFET gate driver. Connect an MLCC bootstrap capacitor from the BOOT pin to the PHASE pin.

UGATE (Pin 18) - High-side MOSFET gate driver output. Connect to the gate of the high-side MOSFET.

PHASE (Pin 19) - Current return path for the UGATE high-side MOSFET gate driver. Detects the polarity of the PHASE node voltage for diode emulation. Connect the PHASE pin to the drains of the low-side MOSFETs.

PGND (Pin 20) - Current return path for the LGATE low-side MOSFET gate driver. The PGND pin only conducts current when LGATE pulls down. Connect the PGND pin to the sources of the low-side MOSFETs.

LGATE (Pin 21) - Low-side MOSFET gate driver output. Connect to the gate of the low-side MOSFET.

PVCC (Pin 22) - Input power supply for the low-side MOSFET gate driver, and the high-side MOSFET gate driver, via the internal bootstrap diode connected between the PVCC and BOOT pins. Connect to +5VDC and decouple with at least 1 μ F of an MLCC capacitor from the PVCC pin to the PGND pin.

VID0:VID4 (Pin 23:Pin 27) - Voltage identification inputs. VID0 input is the least significant bit (LSB) and VID4 input is the most significant bit (MSB).

IMON (Pin 28) - A voltage signal proportional to the output current of the converter.

VR_ON (Pin 29) - A high logic signal on this pin enables the converter and a low logic signal disables the converter.

AF_EN (Pin 30) - Used in conjunction with VID0:VID4 and FDE pins to program the diode-emulation and audio filter behavior. Refer to Table 1.

PGOOD (Pin 31) - The PGOOD pin is an open-drain output that indicates when the converter is able to supply regulated voltage. Connect the PGOOD pin to a maximum of 5V through a pull-up resistor.

FDE (Pin 32) - Used in conjunction with VID0:VID4 and AF_EN pins to program the diode-emulation and audio filter behavior. Refer to Table 1.

BOTTOM - Connects to substrate. Electrically isolated but should be connected to VSS. Requires best practical thermal coupling to PCB.

TABLE 1. DIODE-EMULATION MODE AND AUDIO-FILTER

RENDER MODE	FDE	AF_EN	DEM STATUS	VOLTAGE WINDOW	AUDIO FILTER
PERFORMANCE	0	-	DISABLED	NOM	-
	1	-	ENABLED	130% NOM	-
SUSPEND	-	0	ENABLED	150% NOM	-
	1	1	ENABLED	130% NOM	-
	0	1	ENABLED	130% NOM	ENABLED

TABLE 2. VID TABLE FOR INTEL IMVP-6+
V_{CCGFX} CORE

	VID4	VID3	VID2	VID1	VID0	V _{CCGFX} (V)
RENDER PERFORMANCE STATES	-	-	-	-	-	0
	0	0	0	0	0	1.28750
	0	0	0	0	1	1.26175
	0	0	0	1	0	1.23600
	0	0	0	1	1	1.21025
	0	0	1	0	0	1.18450
	0	0	1	0	1	1.15875
	0	0	1	1	0	1.13300
	0	0	1	1	1	1.10725
	0	1	0	0	0	1.08150
	0	1	0	0	1	1.05575
	0	1	0	1	0	1.03000
	0	1	0	1	1	1.00425
	0	1	1	0	0	0.97850
	0	1	1	0	1	0.95275
	0	1	1	1	0	0.92700
	0	1	1	1	1	0.90125
	RENDER SUSPEND STATES	1	0	0	0	0
1		0	0	0	1	0.84975
1		0	0	1	0	0.82400
1		0	0	1	1	0.79825
1		0	1	0	0	0.77250
1		0	1	0	1	0.74675
1		0	1	1	0	0.72100
1		0	1	1	1	0.69525
1		1	0	0	0	0.66950
1		1	0	0	1	0.64375
1		1	0	1	0	0.61800
1		1	0	1	1	0.59225
1		1	1	0	0	0.56650
1		1	1	0	1	0.54075
1	1	1	1	0	0.51500	
1	1	1	1	1	0.41200	

Theory of Operation

The R³ Modulator

The heart of the ISL6263B is Intersil's Robust-Ripple-Regulator (R³) Technology™. The R³ modulator is a hybrid of fixed frequency PWM control, and variable frequency hysteretic control that will simultaneously affect the PWM switching frequency and PWM duty cycle in response to input voltage and output load transients.

The term "Ripple" in the name "Robust-Ripple-Regulator" refers to the synthesized voltage-ripple signal V_R that appears across the internal ripple-capacitor C_R . The V_R signal is a representation of the output inductor ripple current. Transconductance amplifiers measuring the input voltage of the converter and the output set-point voltage V_{SOFT} , together produce the voltage-ripple signal V_R .

A voltage window signal V_W is created across the VW and COMP pins by sourcing a current proportional to $g_m V_{soft}$ through a parallel network consisting of resistor R_{FSET} and capacitor C_{FSET} . The synthesized voltage-ripple signal V_R along with similar companion signals are converted into PWM pulses.

The PWM frequency is proportional to the difference in amplitude between V_W and V_{COMP} . Operating on these large-amplitude, low noise synthesized signals allows the ISL6263B to achieve lower output ripple and lower phase jitter than either conventional hysteretic or fixed frequency PWM controllers. Unlike conventional hysteretic converters, the ISL6263B has an error amplifier that allows the controller to maintain tight voltage regulation accuracy throughout the VID range from 0.41200V to 1.28750V.

Power-On Reset

The ISL6263B is disabled until the voltage at the VDD pin has increased above the rising VDD power-on reset (POR) V_{DD_THR} threshold voltage. The controller will become disabled when the voltage at the VDD pin decreases below the falling POR V_{DD_THF} threshold voltage.

Start-Up Timing

Figure 4 shows the ISL6263B start-up timing. Once VDD has ramped above V_{DD_THR} , the controller can be enabled by pulling the VR_ON pin voltage above the input-high threshold V_{VR_ONH} . Approximately 100 μ s later, the soft-start capacitor C_{SOFT} begins slewing to the designated VID set-point as it is charged by the soft-start current source I_{SS} . The V_{CCGFX} output voltage of the converter follows the V_{SOFT} voltage ramp to within 10% of the VID set-point then counts 13 switching cycles, then changes the open-drain output of the PGOOD pin to high impedance. During soft-start, the regulator always operates in continuous conduction mode (CCM).

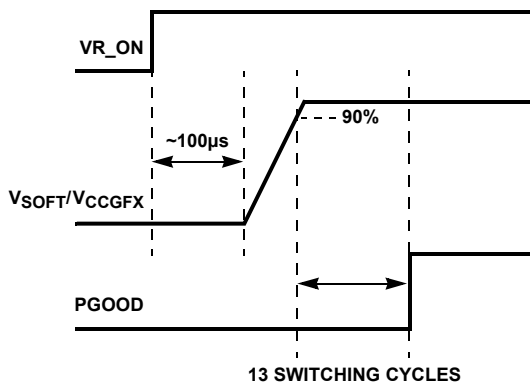

FIGURE 4. ISL6263B START-UP TIMING

Static Regulation

The V_{CCGFX} output voltage will be regulated to the value set by the VID inputs per Table 2. A true differential amplifier connected to the VSEN and RTN pins implements processor socket Kelvin sensing for precise core voltage regulation at the GPU voltage sense points.

As the load current increases from zero, the V_{CCGFX} output voltage will droop from the VID set-point by an amount proportional to the IMVP-6+ load line. The ISL6263B can accommodate DCR current sensing or discrete resistor current sensing. The DCR current sensing uses the intrinsic series resistance of the output inductor as shown in the application circuit of Figure 2. The discrete resistor current sensing uses a shunt connected in series with the output inductor as shown in the application circuit of Figure 3. In both cases the signal is fed to the non-inverting input of the DROOP amplifier at the VSUM pin, where it is measured differentially with respect to the output voltage of the converter at the VO pin and amplified. The voltage at the DROOP pin minus the output voltage measured at the VO pin, is proportional to the total inductor current. This information is used exclusively to achieve the IMVP-6+ load line as well as the overcurrent protection. It is important to note that this current measurement should not be confused with the synthetic current ripple information created within the R^3 modulator.

When using inductor DCR current sensing, an NTC element is used to compensate the positive temperature coefficient of the copper winding thus maintaining the load-line accuracy.

Processor Socket Kelvin Voltage Sensing

The remote voltage sense input pins VSEN and RTN of the ISL6263B are to be terminated at the die of the GPU through connections that mate at the processor socket. (The signal names are V_{cc_sense} and V_{ss_sense} respectively.) Kelvin sensing allows the voltage regulator to tightly control the processor voltage at the die, compensating for various resistive voltage drops in the power delivery path.

Since the voltage feedback is sensed at the processor die, removing the GPU will open the voltage feedback path of the

regulator, causing the output voltage to rise towards V_{IN} . The ISL6263B will shut down when the voltage between the VO and VSS pins exceeds the severe overvoltage protection threshold V_{OVPS} of 1.55V. To prevent this issue from occurring, it is recommended to install resistors R_{Opn1} and R_{Opn2} as shown in Figure 5. These resistors provide voltage feedback from the regulator local output in the absence of the GPU. These resistors should be in the range of 20 Ω to 100 Ω .

High Efficiency Diode Emulation Mode

The ISL6263B operates in continuous-conduction-mode (CCM) during heavy load for minimum conduction loss by forcing the low-side MOSFET to operate as a synchronous rectifier. An improvement in light-load efficiency is achieved by allowing the converter to operate in diode-emulation mode (DEM) where the low-side MOSFET behaves as a smart-diode, forcing the device to block negative inductor current flow.

Positive-going inductor current flows from either the source of the high-side MOSFET, or the drain of the low-side MOSFET. Negative-going inductor current flows into the source of the high-side MOSFET, or into the drain of the low-side MOSFET. When the low-side MOSFET conducts positive inductor current, the phase voltage will be negative with respect to the VSS pin. Conversely, when the low-side MOSFET conducts negative inductor current, the phase voltage will be positive with respect to the VSS pin. Negative inductor current occurs when the output DC load current is less than $\frac{1}{2}$ the inductor ripple current. Sinking negative inductor current through the low-side MOSFET lowers efficiency through unnecessary conduction losses. Efficiency can be further improved with a reduction of unnecessary switching losses by reducing the PWM frequency. The PWM frequency can be configured to automatically make a step-reduction upon entering DEM by forcing a step-increase of the window voltage V_{WV} . The window voltage can be configured to increase approximately 30%, 50%, or not at all. The characteristic PWM frequency reduction, coincident with decreasing load, is accelerated by the step-increase of the window voltage. An audio filter can be enabled that briefly turns on the low-side MOSFET gate driver LGATE approximately every 35 μ s.

The converter will enter DEM after detecting three consecutive PWM pulses with negative inductor current. The negative inductor current is detected during the time that the high-side MOSFET gate driver output UGATE is low, with the exception of a brief blanking period. The voltage between the PHASE pin and VSS pin is monitored by a comparator that latches upon detection of positive phase voltage. The converter will return to CCM after detecting three consecutive PWM pulses with positive inductor current.

The inductor current is considered positive if the phase comparator has not been latched while UGATE is low.

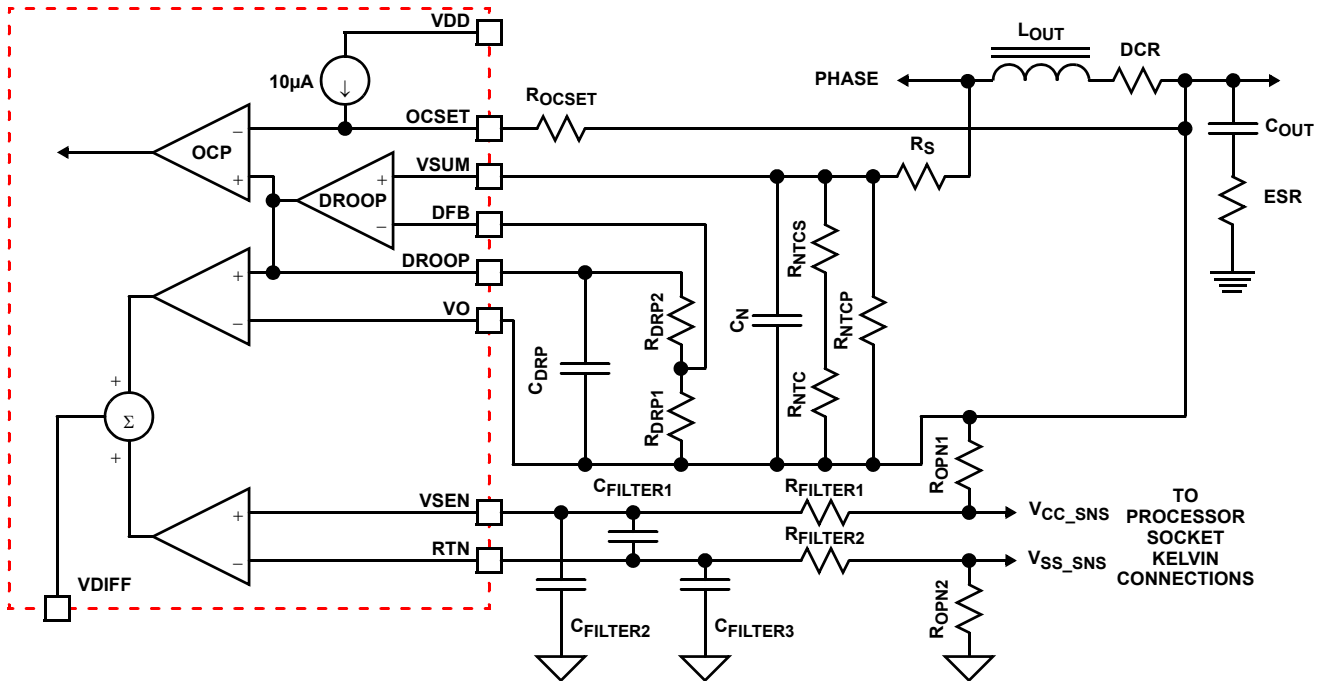

FIGURE 5. SIMPLIFIED VOLTAGE DROOP CIRCUIT WITH GPU SOCKET KELVIN SENSING AND INDUCTOR DCR CURRENT SENSING

Smooth mode transitions are facilitated by the R^3 modulator which correctly maintains the internally synthesized ripple current information throughout mode transitions.

Current Monitor

The ISL6263B features a current monitor output. The voltage between the IMON and VSS pins is proportional to the output inductor current. The output inductor current is proportional to the voltage between the DROOP and VO pins. The IMON pin has source and sink capability for close tracking of transient current events. The current monitor output is expressed in Equation 1:

$$V_{IMON} = (V_{DROOP} - V_O) \cdot 31 \tag{EQ. 1}$$

Protection

The ISL6263B provides overcurrent protection (OCP), overvoltage protection (OVP), and undervoltage protection (UVP) as shown in Table 3.

Overcurrent protection is tied to the voltage droop, which is determined by the resistors selected in the Static Droop Design Using DCR Sensing section. After the load line is set, the OCSET resistor can be selected. The OCP threshold detector is checked every 15µs and will increment a counter if the OCP threshold is exceeded, conversely the counter will be decremented if the load current is below the OCP threshold. The counter will latch an OCP fault when the counter reaches eight. The fastest OCP response for overcurrent levels that are no more than 2.5x the OCP threshold is 120µs, which is eight counts at 15µs each. The ISL6263B protects against hard shorts by latching an OCP fault within 2µs for overcurrent levels exceeding 2.5x the

OCP threshold. The value of R_{OCSET} is calculated in Equation 2:

$$R_{OCSET} = \frac{I_{OC} \cdot R_{droop}}{10.1\mu A} \tag{EQ. 2}$$

For example: The desired overcurrent trip level, I_{OC} , is 30A, R_{droop} load-line is 8mΩ, Equation 2 gives $R_{OCSET} = 24k\Omega$.

Undervoltage protection is independent of the overcurrent protection. If the output voltage measured on the VO pin is less than +300mV below the voltage on the SOFT pin for longer than 1ms, the controller will latch a UVP fault. If the output voltage measured on the VO pin is greater than 195mV above the voltage on the SOFT pin for longer than 1ms, the controller will latch an OVP fault. Keep in mind that V_{SOFT} will equal the voltage level commanded by the VID states only after the soft-start capacitor C_{SOFT} has slewed to the VID DAC output voltage. The UVP and OVP detection circuits act on static and dynamic V_{SOFT} voltage.

When an OCP, OVP, or UVP fault has been latched, PGOOD becomes a low impedance and the gate driver outputs UGATE and LGATE are pulled low. The energy stored in the inductor is dissipated as current flows through the low-side MOSFET body diode. The controller will remain latched in the fault state until the VR_ON pin has been pulled below the falling VR_ON threshold voltage V_{VR_ONL} or until VDD has gone below the falling POR threshold voltage V_{VDD_THF} .

A severe-overvoltage protection fault occurs immediately after the voltage between the VO and VSS pins exceed the rising severe-overvoltage threshold V_{OVP_S} which is 1.545V, the same reference voltage used by the VID DAC. The

ISL6263B will latch UGATE and PGOOD low but unlike other protective faults, LGATE remains high until the voltage between VO and VSS falls below approximately 0.77V, at which time LGATE is pulled low. The LGATE pin will continue to switch high and low at 1.545V and 0.77V until VDD has gone below the falling POR threshold voltage V_{VDD_THF} . This provides maximum protection against a shorted high-side MOSFET while preventing the output voltage from ringing below ground. The severe-overvoltage fault circuit can be triggered after another fault has already been latched.

TABLE 3. FAULT PROTECTION SUMMARY OF ISL6263B

FAULT TYPE	FAULT DURATION PRIOR TO PROTECTION	PROTECTION ACTIONS	FAULT RESET
Overcurrent	120µs	LGATE, UGATE, and PGOOD latched low	Cycle VR_ON or VDD
Short Circuit	<2µs	LGATE, UGATE, and PGOOD latched low	Cycle VR_ON or VDD
Overvoltage (+195mV) between VO pin and SOFT pin	1ms	LGATE, UGATE, and PGOOD latched low	Cycle VR_ON or VDD
Severe Overvoltage (+1.55V) between VO pin and VSS pin	Immediately	UGATE, and PGOOD latched low, LGATE toggles ON when VO > 1.55V OFF when VO < 0.77V until fault reset	Cycle VDD only
Undervoltage (-300mV) between VO pin and SOFT pin	1ms	LGATE, UGATE, and PGOOD latched low	Cycle VR_ON or VDD

Gate-Driver Outputs LGATE and UGATE

The ISL6263B has internal high-side and low-side N-Channel MOSFET gate-drivers. The LGATE driver is optimized for low duty-cycle applications where the low-side MOSFET conduction losses are dominant. The LGATE pull-down resistance is very low in order to clamp the gate-source voltage of the MOSFET below the $V_{GS(th)}$ at turnoff. The current transient through the low-side gate at turnoff can be considerable due to the characteristic large switching charge of a low $r_{DS(ON)}$ MOSFET.

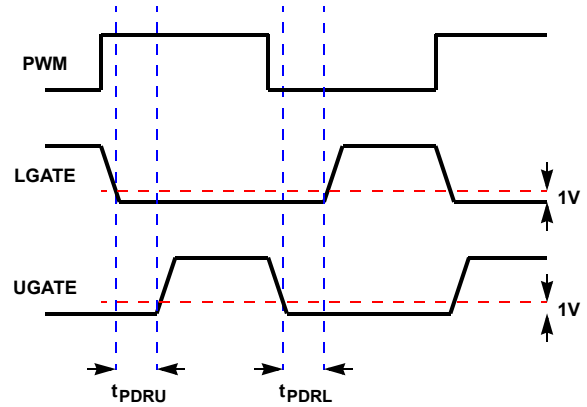

FIGURE 6. GATE DRIVER TIMING DIAGRAM

Adaptive shoot-through protection prevents the gate-driver outputs from going high until the opposite gate-driver output has fallen below approximately 1V. The UGATE turn-on propagation delay t_{PDRU} and LGATE turn-on propagation delay t_{PDRL} are found in the “Electrical Specifications” table on page 6. The power for the LGATE gate-driver is sourced directly from the PVCC pin. The power for the UGATE gate-driver is sourced from a boot-strap capacitor connected across the BOOT and PHASE pins. The boot capacitor is charged from PVCC through an internal boot-strap diode each time the low-side MOSFET turns on, pulling the PHASE pin low.

Internal Bootstrap Diode

The ISL6263B has an integrated boot-strap Schottky diode connected from the PVCC pin to the BOOT pin. Simply adding an external capacitor across the BOOT and PHASE pins completes the bootstrap circuit.

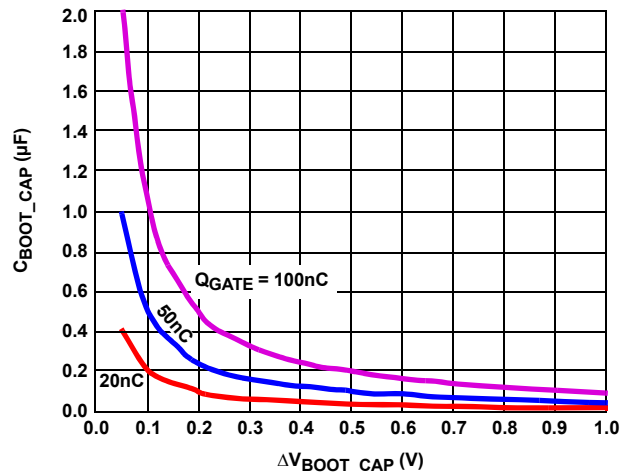

FIGURE 7. BOOTSTRAP CAPACITANCE vs BOOT RIPPLE VOLTAGE

The minimum value of the bootstrap capacitor can be calculated using Equation 3:

$$C_{\text{BOOT}} \geq \frac{Q_{\text{GATE}}}{\Delta V_{\text{BOOT}}} \quad (\text{EQ. 3})$$

where Q_{GATE} is the amount of gate charge required to fully charge the gate of the upper MOSFET. The ΔV_{BOOT} term is defined as the allowable droop in the rail of the upper drive.

As an example, suppose an upper MOSFET has a gate charge, Q_{GATE} , of 25nC at 5V and also assume the droop in the drive voltage at the end of a PWM cycle is 200mV. One will find that a bootstrap capacitance of at least 0.125 μ F is required. The next larger standard value capacitance is 0.15 μ F. A good quality ceramic capacitor is recommended.

Soft-Start and Soft Dynamic VID Slew Rates

The output voltage of the converter tracks V_{SOFT} , the voltage across the SOFT and VSS pins. Shown in Figure 1, the SOFT pin is connected to the output of the VID DAC through the unidirectional soft-start current source I_{SS} or the bidirectional soft-dynamic VID current source I_{DVID} , and the non-inverting input of the error amplifier. Current is sourced from the SOFT pin when I_{SS} is active. The SOFT pin can both source and sink current when I_{DVID} is active. The soft-start capacitor C_{SOFT} changes voltage at a rate proportional to I_{SS} or I_{DVID} . The ISL6263B automatically selects I_{SS} for the soft-start sequence so that the inrush current through the output capacitors is maintained below the OCP threshold. Once soft-start has completed, I_{DVID} is automatically selected for output voltage changes commanded by the VID inputs, charging C_{SOFT} when the output voltage is commanded to rise, and discharging C_{SOFT} when the output voltage is commanded to fall.

The IMVP-6+ Render Voltage Regulator specification requires a minimum of 10mV/ μ s for $\text{SLEWRATE}_{\text{GFX}}$. The value for C_{SOFT} must guarantee the minimum slew-rate of 10mV/ μ s when the soft-dynamic VID current source I_{DVID} is the minimum specified value in the “Electrical Specifications” table on page 7. The value of C_{SOFT} can be calculated using Equation 4:

$$C_{\text{SOFT}} = \frac{I_{\text{DVIDmin}}}{\left(\frac{10\text{mV}}{\mu\text{s}}\right)} = \frac{180\mu\text{A}}{10\text{K}} = 0.018\mu\text{F} \quad (\text{EQ. 4})$$

Choosing the next lower standard component value of 0.015 μ F will guarantee 10mV/ μ s $\text{SLEWRATE}_{\text{GFX}}$. This choice of C_{SOFT} controls the startup slew-rate as well. One should expect the output voltage during soft-start to slew to the voltage commanded by the VID settings at a nominal rate given by Equation 5:

$$\frac{dV_{\text{SOFT}}}{dt} = \frac{I_{\text{SS}}}{C_{\text{SOFT}}} = \frac{42\mu\text{A}}{0.015\mu\text{F}} \approx \frac{2.8\text{mV}}{\mu\text{s}} \quad (\text{EQ. 5})$$

Note that the slewwrate is the average rate of change between the initial and final voltage values.

RBIAS Current Reference

The RBIAS pin is internally connected to a 1.545V reference through a 3k Ω resistance. A bias current is established by connecting a $\pm 1\%$ tolerance, 150k Ω resistor between the RBIAS and VSS pins. This bias current is mirrored, creating the reference current I_{OCSET} that is sourced from the OCSET pin. Do not connect any other components to this pin, as they will have a negative impact on the performance of the IC.

Setting the PWM Switching Frequency

The R³ modulator scheme is not a fixed-frequency architecture, lacking a fixed-frequency clock signal to produce PWM. The switching frequency increases during the application of a load to improve transient performance. The static PWM frequency varies slightly depending on the input voltage, output voltage, and output current, but this variation is normally less than 10% in continuous conduction mode.

Refer to Figure 2 and find that resistor R_{FSET} is connected between the VW and COMP pins. A current is sourced from VW through R_{FSET} creating the synthetic ripple window voltage signal V_{W} which determines the PWM switching frequency. The relationship between the resistance of R_{FSET} and the switching frequency in CCM is approximated by Equation 6:

$$R_{\text{FSET}} = \frac{(T - 0.5 \times 10^{-6})}{400 \times 10^{-12}} \quad (\text{EQ. 6})$$

For example, the value of R_{FSET} for 300kHz operation is approximately:

$$7.1 \times 10^3 = \frac{(3.33 \times 10^{-6} - 0.5 \times 10^{-6})}{400 \times 10^{-12}} \quad (\text{EQ. 7})$$

This relationship only applies to operation in constant conduction mode because the PWM frequency naturally decreases as the load decreases while in diode emulation mode.

Static Droop Design Using DCR Sensing

The ISL6263B has an internal differential amplifier to accurately regulate the voltage at the processor die.

For DCR sensing, the process to compensate the DCR resistance variation takes several iterative steps. Figure 2 shows the DCR sensing method. Figure 8 shows the simplified model of the droop circuitry. The inductor DC current generates a DC voltage drop on the inductor DCR. Equation 8 gives this relationship

$$V_{\text{DCR}} = I_{\text{o}} \cdot \text{DCR} \quad (\text{EQ. 8})$$

An R-C network senses the voltage across the inductor to get the inductor current information. R_{NTCEQ} represents the NTC network consisting of R_{NTC} , R_{NTCS} , and R_{NTCP} . The choice of R_{S} will be discussed in the next section.

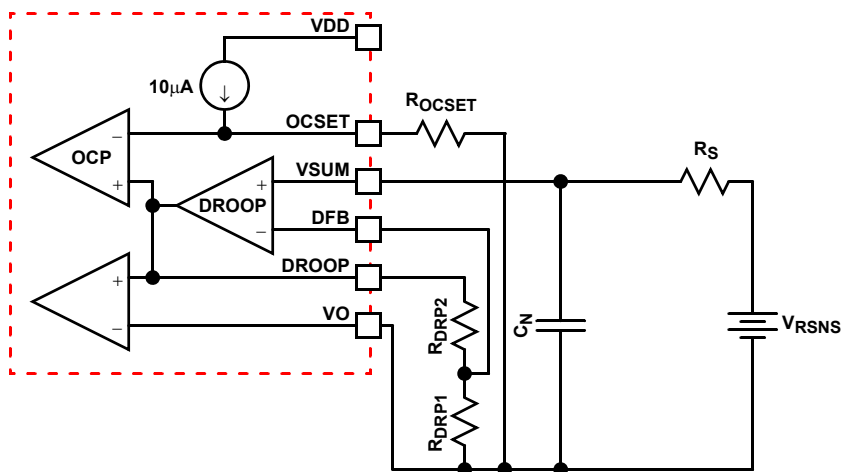

FIGURE 9. EQUIVALENT MODEL FOR DROOP CIRCUIT USING DISCRETE RESISTOR CURRENT SENSING

Following the evaluation board value and layout of NTC placement will minimize the engineering time.

The current sensing traces should be routed directly to the inductor pads for accurate DCR voltage drop measurement. However, due to layout imperfection, the calculated R_{DRP2} may still need slight adjustment to achieve optimum load line slope. It is recommended to adjust R_{DRP2} after the system has achieved thermal equilibrium at full load. For example, if the maximum load current is 20A, one should apply a 20A load current and look for 160mV output voltage droop. If the voltage droop is 155mV, the new value of R_{DRP2} is calculated by Equation 17:

$$R_{DRP2_{new}} = \frac{160mV}{155mV} \cdot (R_{DRP1} + R_{DRP2}) - R_{DRP1} \quad (EQ. 17)$$

For the best accuracy, the effective resistance on the DFB and VSUM pins should be identical so that the bias current of the droop amplifier does not cause an offset voltage.

Dynamic Droop Capacitor Design Using DCR Sensing

Figure 10 shows the desired waveforms during load transient response. V_{CCGFX} needs to follow the change in I_{core} as close as possible. The transient response of V_{CCGFX} is determined by several factors, namely the choice of output inductor, output capacitor, compensator design, and the design of droop capacitor C_N .

If C_N is designed correctly, the voltage $V_{DROOP} - V_O$ will be an excellent representation of the inductor current. Given the correct C_N design, V_{CCGFX} has the best chance of tracking I_{CORE} , if not, its voltage will be distorted from the actual waveform of the inductor current and worsens the transient response. Figure 11 shows the transient response when C_N is too small allowing V_{CCGFX} to sag excessively during the load transient. Figure 12 shows the transient response when C_N is too large. V_{CCGFX} takes too long to droop to its final value.

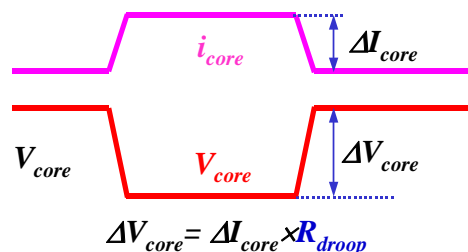

FIGURE 10. DESIRED LOAD TRANSIENT RESPONSE WAVEFORMS

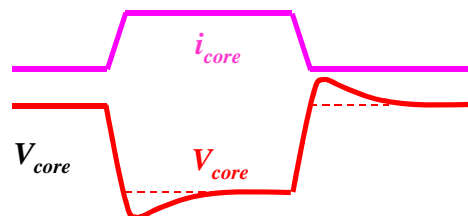

FIGURE 11. LOAD TRANSIENT RESPONSE WHEN C_N IS TOO SMALL

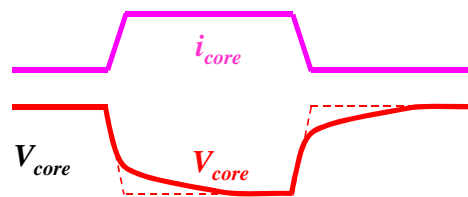

FIGURE 12. LOAD TRANSIENT RESPONSE WHEN C_N IS TOO LARGE

The current sensing network consists of R_{NTCEQ} , R_S , and C_N . The effective resistance is the parallel of R_{NTCEQ} and R_S . The RC time constant of the current sensing network needs to match the L/DCR time constant of the inductor to get the correct representation of the inductor current waveform. Equation 18 shows this relationship:

$$\frac{L}{DCR} = \left(\frac{R_{NTCEQ} \cdot R_S}{R_{NTCEQ} + R_S} \right) \cdot C_N \quad (\text{EQ. 18})$$

Solution of C_N yields:

$$C_N = \frac{\left(\frac{L}{DCR} \right)}{\left(\frac{R_{NTCEQ} \cdot R_S}{R_{NTCEQ} + R_S} \right)} \quad (\text{EQ. 19})$$

For example: $L = 0.45\mu\text{H}$, $DCR = 1.1\text{m}\Omega$, $R_S = 7.68\text{k}\Omega$, and $R_{NTCEQ} = 3.4\text{k}\Omega$:

$$C_N = \frac{\left(\frac{0.45\mu\text{H}}{1.1\text{m}\Omega} \right)}{\left(\frac{3.4\text{k}\Omega \cdot 7.68\text{k}\Omega}{3.4\text{k}\Omega + 7.68\text{k}\Omega} \right)} = 174\text{nF} \quad (\text{EQ. 20})$$

Since the inductance and the DCR typically have 20% and 7% tolerance respectively, C_N needs to be fine tuned on the actual board by examining the transient voltage. It is recommended to choose the minimum capacitance based on the maximum inductance. C_N also needs to be a high-grade capacitor such as NPO/COG or X7R with tight tolerance. The NPO/COG caps are only available in small capacitance values. In order to use such capacitors, the resistors and thermistors surrounding the droop voltage sensing and droop amplifier need to be scaled up 10x to reduce the capacitance by 10x.

Static and Dynamic Droop using Discrete Resistor Sensing

Figure 3 shows a detailed schematic using discrete resistor sensing of the inductor current. Figure 9 shows the equivalent circuit. Since the current sensing resistor voltage represents the actual inductor current information, R_S and C_N simply provide noise filtering. A low ESL sensing resistor is strongly recommended for R_{SNS} because this parameter is the most significant source of noise that affects discrete resistor sensing. It is recommended to start out using 100Ω for R_S and 47pF for C_N . Since the current sensing resistance changes very little with temperature, the NTC network is not needed for thermal compensation. Discrete resistor sensing droop design follows the same approach as DCR sensing. The voltage on the current sensing resistor is given by Equation 21:

$$V_{RSNS} = I_o \cdot R_{SNS} \quad (\text{EQ. 21})$$

Equation 22 shows the droop amplifier gain. So the actual droop is given by:

$$R_{\text{droop}} = R_{SNS} \cdot \left(1 + \frac{R_{DRP2}}{R_{DRP1}} \right) \quad (\text{EQ. 22})$$

Solution to R_{DRP2} yields Equation 23 :

$$R_{DRP2} = R_{DRP1} \cdot \left(\frac{R_{\text{droop}}}{R_{SNS}} - 1 \right) \quad (\text{EQ. 23})$$

For example: $R_{\text{droop}} = 8.0\text{m}\Omega$, $R_{SNS} = 1.0\text{m}\Omega$, and $R_{DRP1} = 1\text{k}\Omega$, R_{DRP2} then = $7\text{k}\Omega$.

The current sensing traces should be routed directly to the current sensing resistor pads for accurate measurement. However, due to layout imperfection, the calculated R_{DRP2} may still need slight adjustment to achieve optimum load line slope. It is recommended to adjust R_{DRP2} after the system has achieved thermal equilibrium at full load.

Dynamic Mode of Operation - Compensation Parameters

The voltage regulator is equivalent to a voltage source in series with the output impedance. The voltage source is the VID state and the output impedance is $8.0\text{m}\Omega$ in order to achieve the 8.0mV/A load line. It is highly recommended to design the compensation such that the regulator output impedance is $8.0\text{m}\Omega$. Intersil provides a spreadsheet to calculate the compensator parameters. Caution needs to be used in choosing the input resistor to the FB pin. Excessively high resistance will cause an error to the output voltage regulation due to the bias current flowing through the FB pin. It is recommended to keep this resistor below $3\text{k}\Omega$.

Layout Considerations

As a general rule, power should be on the bottom layer of the PCB and weak analog or logic signals are on the top layer of the PCB. The ground-plane layer should be adjacent to the top layer to provide shielding.

Inductor Current Sensing and the NTC Placement

It is crucial that the inductor current be sensed directly at the PCB pads of the sense element, be it DCR sensed or discrete resistor sensed. The effect of the NTC on the inductor DCR thermal drift is directly proportional to its thermal coupling with the inductor and thus, the physical proximity to it.

Signal Ground and Power Ground

The ground plane layer should have a single point connection to the analog ground at the VSS pin. The VSS island should be located under the IC package along with the weak analog traces and components. The paddle on the bottom of the ISL6263B QFN package is not electrically connected to the IC however, it is recommended to make a good thermal connection to the VSS island using several vias. Connect the input capacitors, the output capacitors, and the source of the lower MOSFETs to the power ground plane.

LGATE, PVCC, and PGND

PGND is the return path for the pull-down of the LGATE low-side MOSFET gate driver. Ideally, PGND should be connected to the source of the low-side MOSFET with a low-resistance, low-inductance path. The LGATE trace should be routed in parallel with the trace from the PGND pin. These two traces should be short, wide, and away from other traces because of the high peak current and extremely fast dv/dt . PVCC should be decoupled to PGND with a ceramic capacitor physically located as close as practical to the IC pins.

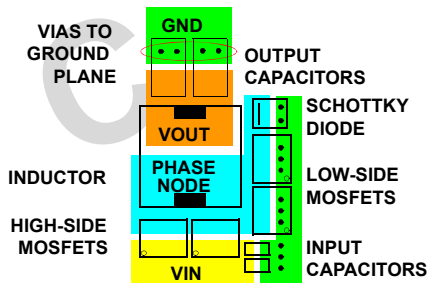

FIGURE 13. TYPICAL POWER COMPONENT PLACEMENT

UGATE, BOOT, and PHASE

PHASE is the return path for the entire UGATE high-side MOSFET gate driver. The layout for these signals require similar treatment, but to a greater extent, than those for LGATE, PVCC, and PGND. These signals swing from approximately VIN to VSS and are more likely to couple into other signals.

VSEN and RTN

These traces should be laid out as noise sensitive. For optimum load line regulation performance, the traces connecting these two pins to the Kelvin sense leads of the processor should be laid out away from rapidly rising voltage nodes, (switching nodes) and other noisy traces. The filter capacitors $C_{FILTER1}$, $C_{FILTER2}$, and $C_{FILTER3}$ used in conjunction with filter resistors $R_{FILTER1}$ and $R_{FILTER2}$ form common mode and differential mode filters as shown in Figure 8. The noise environment of the application and actual board layout conditions will drive the extent of filter complexity. The maximum recommended resistance for $R_{FILTER1}$ and $R_{FILTER2}$ is approximately 10Ω to avoid interaction with the $50k\Omega$ input resistance of the remote sense differential amplifier. The physical location of these resistors is not as critical as the filter capacitors. Typical capacitance values for $C_{FILTER1}$, $C_{FILTER2}$, and $C_{FILTER3}$ range between 330pF to 1000pF and should be placed near the IC.

All Intersil U.S. products are manufactured, assembled and tested utilizing ISO9000 quality systems. Intersil Corporation's quality certifications can be viewed at www.intersil.com/design/quality

Intersil products are sold by description only. Intersil Corporation reserves the right to make changes in circuit design, software and/or specifications at any time without notice. Accordingly, the reader is cautioned to verify that data sheets are current before placing orders. Information furnished by Intersil is believed to be accurate and reliable. However, no responsibility is assumed by Intersil or its subsidiaries for its use; nor for any infringements of patents or other rights of third parties which may result from its use. No license is granted by implication or otherwise under any patent or patent rights of Intersil or its subsidiaries.

For information regarding Intersil Corporation and its products, see www.intersil.com

RBIAS

The resistor R_{RBIAS} should be placed in close proximity to the ISL6263B using a noise-free current return path to the VSS pin.

IMON, SOFT, OCSET, VW, COMP, FB, VDIFF, DROOP, DFB, VO, and VSUM

The traces and components associated with these pins require close proximity to the IC as well as close proximity to each other. This section of the converter circuit needs to be located above the island of analog ground with the single-point connection to the VSS pin.

Resistor R_S

Resistor R_S is preferably located near the boundary between the power ground and the island of analog ground connected to the VSS pin.

VID<0:4>, AF_EN, PGOOD, and VR_ON

These are logic signals that do not require special attention.

FDE

This logic signal should be treated as noise sensitive and should be routed away from rapidly rising voltage nodes, (switching nodes) and other noisy traces.

VIN

The VIN signal should be connected near the drain of the high-side MOSFET.

Copper Size for the Phase Node

The parasitic capacitance and parasitic inductance of the phase node should be kept very low to minimize ringing. It is best to limit the size of the PHASE node copper in strict accordance with the current and thermal management of the application. An MLCC should be connected directly across the drain of the high-side MOSFET and the source of the low-side MOSFET to suppress turn-off voltage spikes.

Package Outline Drawing

L32.5x5

32 LEAD QUAD FLAT NO-LEAD PLASTIC PACKAGE

Rev 2, 02/07

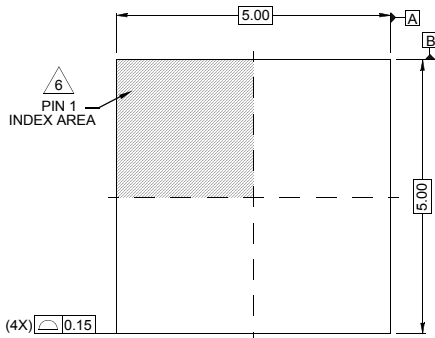

TOP VIEW

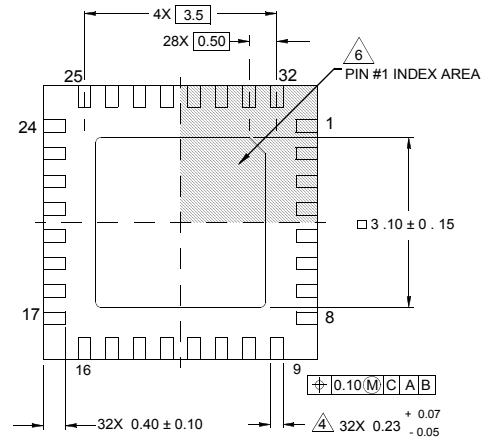

BOTTOM VIEW

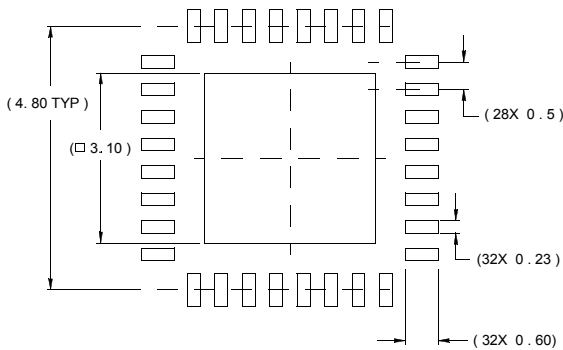

TYPICAL RECOMMENDED LAND PATTERN

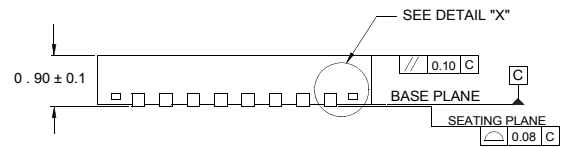

SIDE VIEW

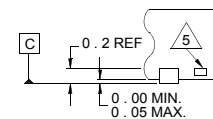

DETAIL "X"

NOTES:

1. Dimensions are in millimeters.
Dimensions in () for Reference Only.
2. Dimensioning and tolerancing conform to AMSE Y14.5m-1994.
3. Unless otherwise specified, tolerance : Decimal ± 0.05
4. Dimension b applies to the metallized terminal and is measured between 0.15mm and 0.30mm from the terminal tip.
5. Tiebar shown (if present) is a non-functional feature.
6. The configuration of the pin #1 identifier is optional, but must be located within the zone indicated. The pin #1 identifier may be either a mold or mark feature.