

---

## Multifunction voltage regulator for car radio

---

### Features

- Four outputs:
  - 8.5 V @ 500 mA
  - 5 V @ 300 mA permanent
  - 5 V @ 800 mA
  - 3.3 V @ 800 mA
- 2 A high side driver
- Reset function
- Ignition comparator
- Load dump protection
- Thermal shutdown
- Overcurrent limitation
- All pins ESD protected

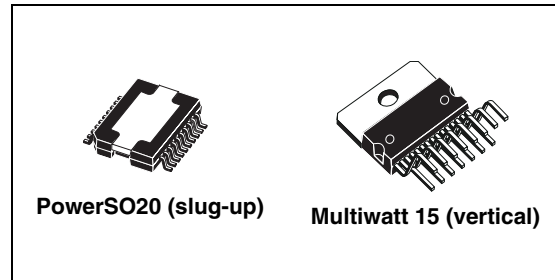

### Description

The L5956 contains a triple voltage regulator and a power switch.

The IC includes a monitoring circuit for detection.

The IC features a very low quiescent under standby.

**Table 1. Device summary**

Order code	Package	Packing
L5956	Multiwatt 15 (vertical)	Tube
L5956PD	PowerSO20	Tube
L5956PDTR	PowerSO20	Tape and reel

---

# Contents

<b>1</b>	<b>Block diagram and pins description</b> .....	<b>5</b>
1.1	Block diagram .....	5
1.2	Pins description .....	5
<b>2</b>	<b>Electrical specifications</b> .....	<b>6</b>
2.1	Absolute maximum ratings .....	6
2.2	Thermal data .....	6
2.3	Electrical characteristics .....	6
<b>3</b>	<b>Timing diagrams</b> .....	<b>11</b>
<b>4</b>	<b>Package information</b> .....	<b>14</b>
<b>5</b>	<b>Revision history</b> .....	<b>16</b>

## List of tables

Table 1.	Device summary . . . . .	1
Table 2.	Absolute maximum ratings . . . . .	6
Table 3.	Thermal data. . . . .	6
Table 4.	Electrical characteristics . . . . .	6
Table 5.	Document revision history . . . . .	16

## List of figures

Figure 1.	Block diagram . . . . .	5
Figure 2.	Pins connection (top view) . . . . .	5
Figure 3.	Typical application circuit . . . . .	10
Figure 4.	Maximum ESR for stability valid for all the regulators outputs . . . . .	10
Figure 5.	Timing diagram of regulators and power switch . . . . .	11
Figure 6.	Backup and reset diagram . . . . .	11
Figure 7.	Hold and thermal protection . . . . .	12
Figure 8.	Ignition buffer diagram . . . . .	12
Figure 9.	Protection of the power switch . . . . .	12
Figure 10.	Short circuit diagram . . . . .	13
Figure 11.	PowerSO20 (slug-up) mechanical data and package dimensions . . . . .	14
Figure 12.	Multiwatt 15 (vertical) mechanical data and package dimensions . . . . .	15

# 1 Block diagram and pins description

## 1.1 Block diagram

Figure 1. Block diagram

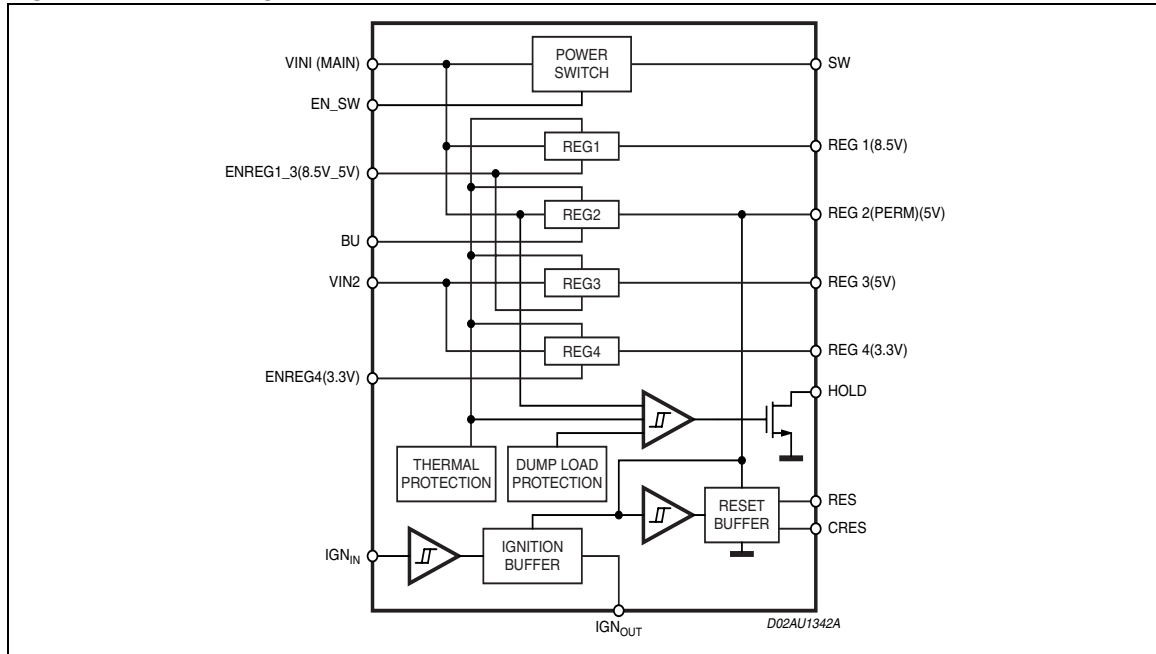

## 1.2 Pins description

Figure 2. Pins connection (top view)

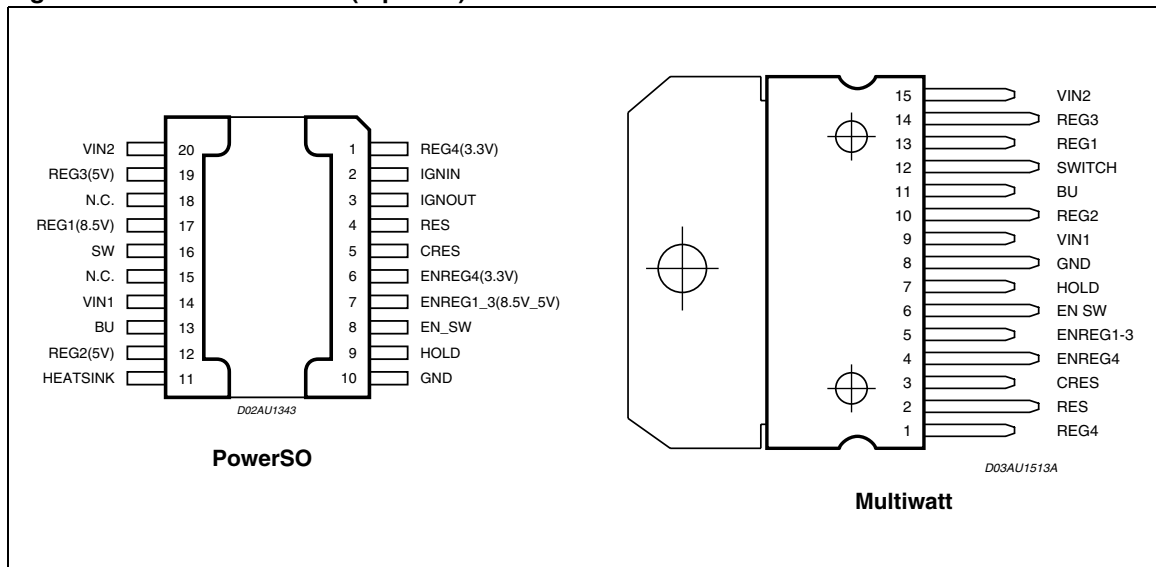

## 2 Electrical specifications

### 2.1 Absolute maximum ratings

Table 2. Absolute maximum ratings

Symbol	Parameter	Value	Unit
$V_{SDC}$	DC operating supply voltage	30	V
$V_{STR}$	Transient supply voltage	50	V
$I_O$	Output current	internally limited	
$T_{op}$	Operating temperature range	-40 to 85	°C
$T_{stg}$	Storage temperature	-55 to 150	°C
$T_j$	Junction temperature	-55 to 150	°C
$P_d$	Power dissipation at $T_{case} = 85\text{ °C}$	43	W

### 2.2 Thermal data

Table 3. Thermal data

Symbol	Parameter	PowerSO	Multiwatt	Unit
$R_{th\ j-case}$	Thermal resistance junction-to-case	Max. 1.5	1.8	°C/W

### 2.3 Electrical characteristics

$V_S = 14.4\text{ V}$ ;  $T_{amb} = 25\text{ °C}$ ; unless otherwise specified.

Table 4. Electrical characteristics

Symbol	Parameter	Test condition	Min.	Typ.	Max.	Unit
<b>INPUT SUPPLIES</b>						
$V_{in1}$	Input supply voltage 1	Operating	9	-	18	V
$V_{in2}$	Input supply voltage 2	Operating	6	-	18	V
$V_{in1}$	Input supply voltage 1	Reverse polarity	non operating			
$V_{in2}$	Input supply voltage 2	Reverse polarity	non operating			
$I_q$	Total quiescent current	Standby (-20 °C to 85 °C) IGN <sub>IN</sub> = 5 V	-	-	60	μA
		REGx = 5 V, REGsw = 5 V, IGN <sub>IN</sub> = 5 V	-	5	-	mA
		Standby (-20 °C to 85 °C) IGN <sub>IN</sub> = 5 V, V <sub>CC</sub> = 18 V	-	100	170	μA

Table 4. Electrical characteristics (continued)

Symbol	Parameter	Test condition	Min.	Typ.	Max.	Unit
Load dump $V_{in1}$	Battery overvoltage	$V_{in1}$	18	20	22	V
Load dump $V_{in2}$	Battery overvoltage	$V_{in2}$	18	20	22	V
<b>REGULATOR 1</b>						
$V_o$ (REG 1)	Output voltage 8.5 V	-	8	8.5	9	V
$\Delta V$	Line regulation	$V_{in1} = 10$ to 18 V; $I = 500$ mA	-	-	50	mV
$\Delta V$	Line regulation	$V_{in1} = 9.3$ to 18 V; $I = 10$ mA	-	-	50	mV
$\Delta V_i$	Load regulation	$I_{reg1} = 1$ to 500 mA	-	-	100	mV
$I_q$	Quiescent current	$I_{reg1} = 10$ mA	-	-	5	mA
PSRR	Supply voltage ripple rejection	$f = 1$ kHz; $V_{in1} = 1.5$ Vpp; $I_o = 500$ mA	50	-	-	dB
$V_{drop}$	Drop out voltage	$I_{reg1} = 500$ mA <sup>(1)</sup>	-	-	0.6	V
$I_m$	Current limit	$R_{short} = 0.5 \Omega$	0.6	-	1.2	A
<b>REGULATOR 2</b>						
$V_o$ (ST BY)	Output voltage 5 V	-	4.75	5	5.25	V
$\Delta V$	Line regulation	$V_{in1} = 7$ to 18 V; $I = 300$ mA	-	-	50	mV
$\Delta V$	Line regulation	$V_{in1} = 6$ to 18 V; $I = 10$ mA	-	-	50	mV
$\Delta V_i$	Load regulation	$I_{reg2} = 1$ to 300 mA	-	-	100	mV
$I_q$	Quiescent current	$I_{reg2} = 10$ mA	-	-	3	mA
PSRR	Supply voltage ripple rejection	$f = 1$ kHz; $V_{in1} = 1.5$ Vpp; $I_o = 300$ mA	50	-	-	dB
$V_{drop}$	Drop out voltage	$I_{reg2} = 300$ mA <sup>(1)</sup>	-	-	1.5	V
$V_{drop}$	Drop out voltage	$I_{reg2} = 100$ mA <sup>(1)</sup>	-	-	0.6	V
$I_m$	Current limit	$R_{short} = 0.5 \Omega$	400	-	800	mA
<b>REGULATOR 3</b>						
$V_o$ (REG 3)	Output voltage 5V	-	4.75	5	5.25	V
$\Delta V$	Line regulation	$V_{in2} = 7$ to 18 V; $I = 800$ mA	-	-	50	mV
$\Delta V$	Line regulation	$V_{in2} = 6$ to 18 V; $I = 10$ mA	-	-	50	mV
$\Delta V_i$	Load regulation	$I_{reg3} = 1$ to 800 mA	-	-	100	mV
$I_q$	Quiescent current	$I_{reg3} = 10$ mA	-	-	5	mA
PSRR	Supply voltage ripple rejection	$f = 1$ kHz; $V_{in1} = 1.5$ Vpp; $I_o = 800$ mA	50	-	-	dB
$V_{drop}$	Drop out voltage	$I_{reg3} = 800$ mA <sup>(1)</sup>	-	-	1.5	V
$I_m$	Current limit	$R_{short} = 0.5 \Omega$	1	-	2	A

Table 4. Electrical characteristics (continued)

Symbol	Parameter	Test condition	Min.	Typ.	Max.	Unit
<b>REGULATOR 4</b>						
$V_o$ (REG 4)	Output voltage 3.3 V	-	3.15	3.3	3.45	V
$\Delta V$	Line regulation	$V_{in2} = 6$ to 18 V; $I = 800$ mA	-	-	50	mV
$\Delta V$	Line regulation	$V_{in2} = 6$ to 18 V; $I = 10$ mA	-	-	50	mV
$\Delta V_i$	Load regulation	$I_{reg4} = 1$ to 800 mA	-	-	100	mV
$I_q$	Quiescent current	$I_{reg4} = 10$ mA	-	-	5	mA
PSRR	Supply voltage ripple rejection	$f = 1$ kHz; $V_{in1} = 1.5$ Vpp; $I_o = 800$ mA	50	-	-	dB
$V_{drop}$	Drop out voltage	$I_{reg4} = 800$ mA <sup>(1)</sup>	-	-	2.5	V
$I_m$	Current limit	$R_{short} = 0.5 \Omega$	1	-	2	A
<b>POWER SWITCH</b>						
$V_{dropSW}$	Drop voltage power switch	$I_{dcSW} = 1.8$ A max.	-	-	0.5	V
$I_{pSW1}$	Peak current power switch	Peak time < 15 ms	2	-	3.5	A
$I_{pSW2}$	Peak current power switch	Peak time > 40 ms	1	-	2	A
$SW_{DEL}$	Delay protection	-	15	-	40	ms
<b>RESET BUFFER (with push-pull buffer)</b>						
RES	RES falling	$V_{reg2} = 5$ V	4.6	4.7	4.8	V
RES	RES rising	$V_{reg2} = 5$ V	4.65	4.8	4.95	V
$V_{HYS(RES)}$	Hysteresis of reset buffer	-	50	100	200	mV
$I_{Hsource(RES)}$	High level source current	Reset = 0 V	1000	1300	1600	$\mu$ A
$I_{Lsink(RES)}$	Low level sink current	Reset = 5 V	14	16	18	mA
$RES_{delay}$	$C_{res} = 47$ nF	-	10	-	60	ms
$\Delta T_{RES}$	Reset rise and fall time	$R = 10$ k $\Omega$ , $C = 15$ pF	-	-	50	$\mu$ s
$I_{charge}$	Charge current	$C_{RES} = 0$ V	3	5	10	$\mu$ A
$I_{Discharge}$	Discharge current	$C_{RES} = 5$ V	1	-	3	mA
$V_{TH(F)}$	Falling voltage threshold	-	1	1.2	1.4	V
$V_{TH(R)}$	Rising voltage threshold	-	2.5	2.8	3.5	V
$V_{ol}$	Low level	$I_{SINK(RES)} = 1$ mA	-	0.3	0.5	V
$V_{oh}$	High level	-	4.5	$V_{reg2}$	5.5	V
<b>HOLD SIGNAL</b>						
$V_{lowl}$	Hold output low for $V_{in1}$ low	Low detection	-	-	9	V
$V_{lowh}$	Hold output high for $V_{in1}$ normal	Normal high detection	10	-	18	V
$V_{lowl}$	Hold output low for $V_{in1}$ high	low detection	22	-	-	V



Table 4. Electrical characteristics (continued)

Symbol	Parameter	Test condition	Min.	Typ.	Max.	Unit
$V_{\text{HOLD R}}$	Low $V_{\text{IN1}}$ threshold	$V_{\text{IN1}}$ Low TH.	9	9.5	10	V
$V_{\text{HYS (HOLD\_L)}}$	Hysteresis low TH.	-	50	150	200	mV
$V_{\text{HOLD F}}$	High $V_{\text{IN1}}$ threshold	$V_{\text{IN1}}$ High TH.	18	20	22	V
$V_{\text{HYS (HOLD\_M)}}$	Hysteresis high TH.	-	200		500	mV
<b>IGNITION BUFFER (push-pull with Schmidt trigger)</b>						
$\text{IGN}_{\text{IN}}$	$\text{IGN}_{\text{out}}$ falling	-	1.03	1.17	1.28	V
$\text{IGN}_{\text{IN}}$	$\text{IGN}_{\text{out}}$ rising	-	1.18	1.27	1.33	V
$V_{\text{hys(IGNout)}}$	Hysteresis of ignition buffer	-	-	50	-	mV
$\text{IH}_{\text{source(IGNout)}}$	High level source current	$\text{IGN}_{\text{out}} = 0 \text{ V}$	1000	1500	2000	$\mu\text{A}$
$\text{IL}_{\text{sink(IGNout)}}$	Low level sink current	$\text{IGN}_{\text{out}} = 5 \text{ V}$	10	15	20	mA
$V_{\text{ol}}$	Low level	$\text{IL}_{\text{sink (IGNout)}} = 1 \text{ mA}$	-	0.3	0.5	V
$V_{\text{oh}}$	High level	-	4.5	Vreg2	5.5	V
$\text{IGN}_{\text{RISE}}$	Rising time	$C = 15 \text{ pF}$	-	-	10	$\mu\text{s}$
$\text{IGN}_{\text{FALL}}$	Fall time	$C = 15 \text{ pF}$	-	-	10	$\mu\text{s}$
$\text{I}_{\text{CLAMP}}$	Input clamp current	$V_{\text{CC}} < V_{\text{IGN}} < 50 \text{ V}$	-	-	2	mA
$\text{IGN}_{\text{IN}}$	Input voltage	Operative	0	-	50	V
<b>ENABLE INPUT (regulators 1,3,4 and power switch)</b>						
$V_{\text{TH}}$	Voltage threshold	-	1.3	1.8	2.3	V
$\text{EN}_{\text{IN}}$	Input voltage	Operative	0	-	5	V

1. Drop condition means that the supply voltage drop down to 100 mV from the regulated output and the regulator is sourcing its maximal load current.

Figure 3. Typical application circuit

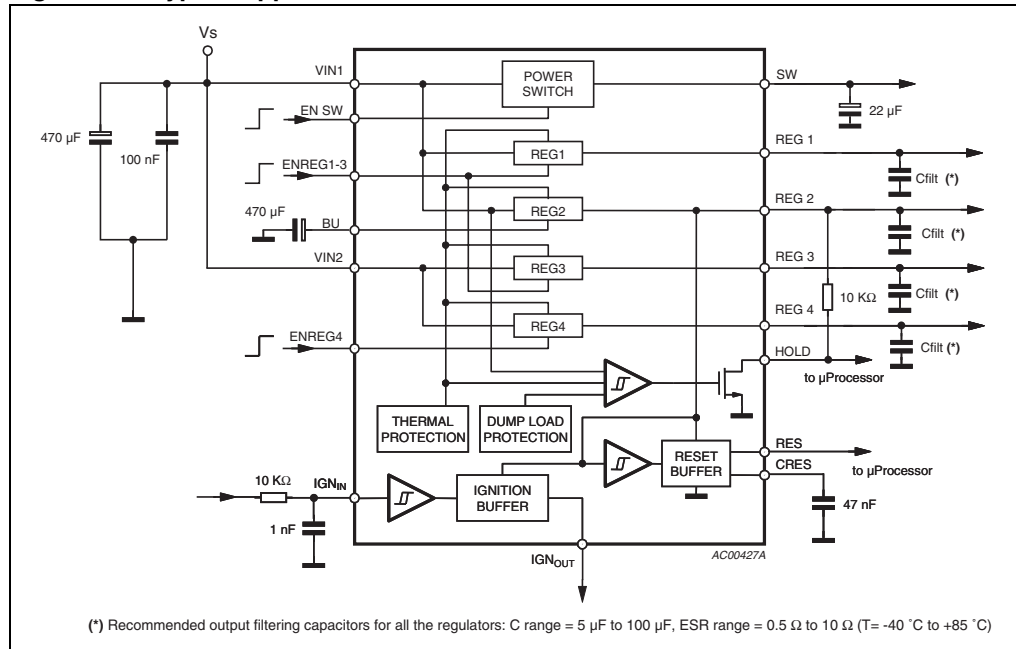
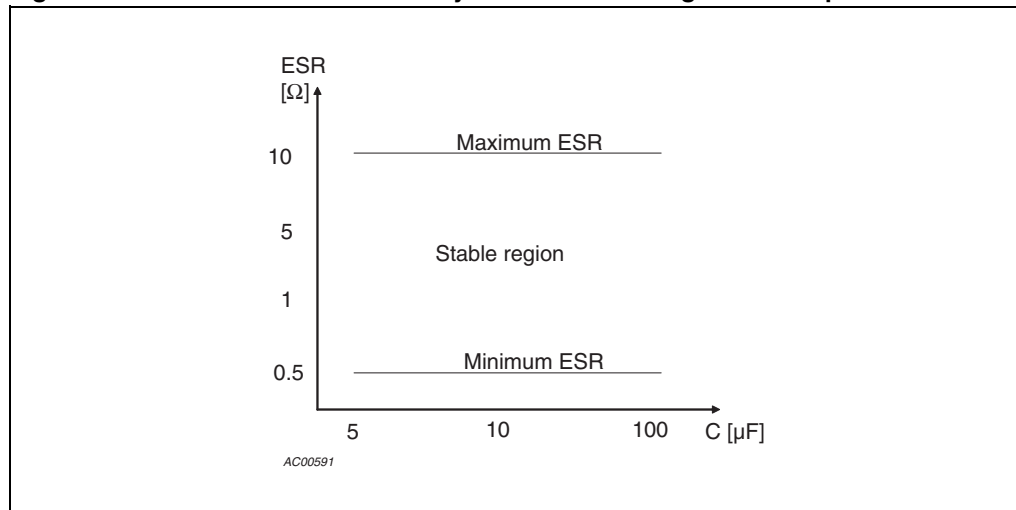

Figure 4. Maximum ESR for stability valid for all the regulators outputs



### 3 Timing diagrams

Figure 5. Timing diagram of regulators and power switch

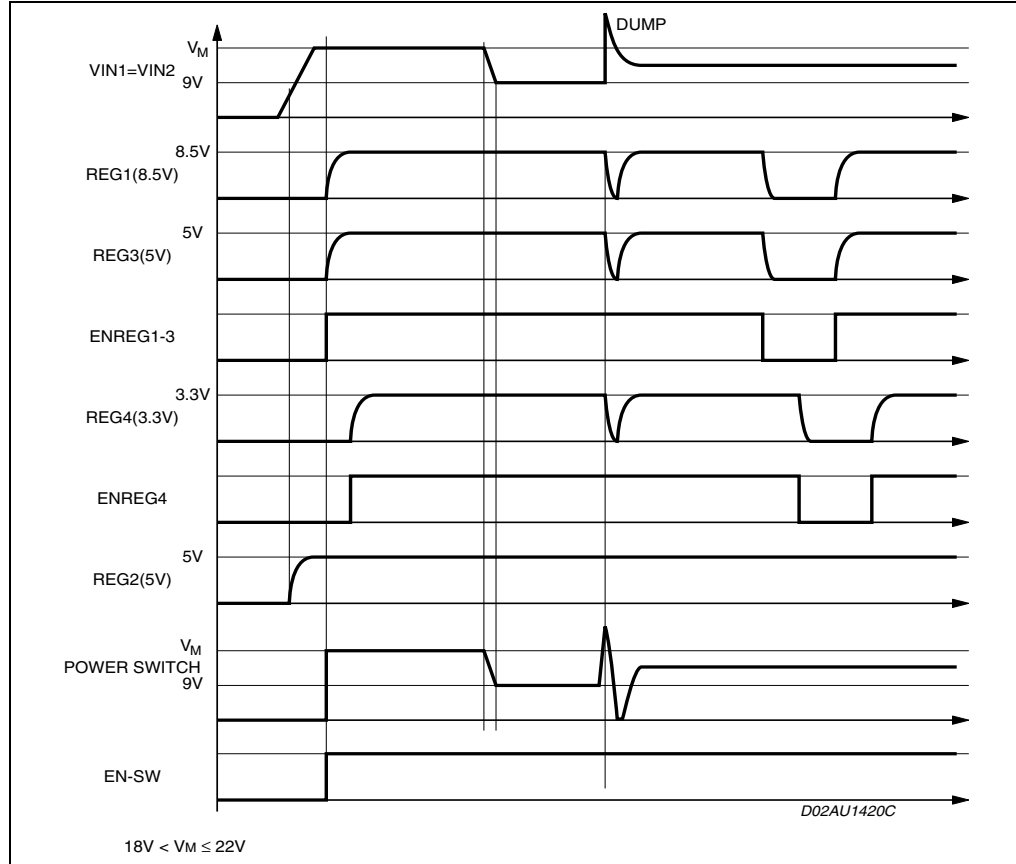
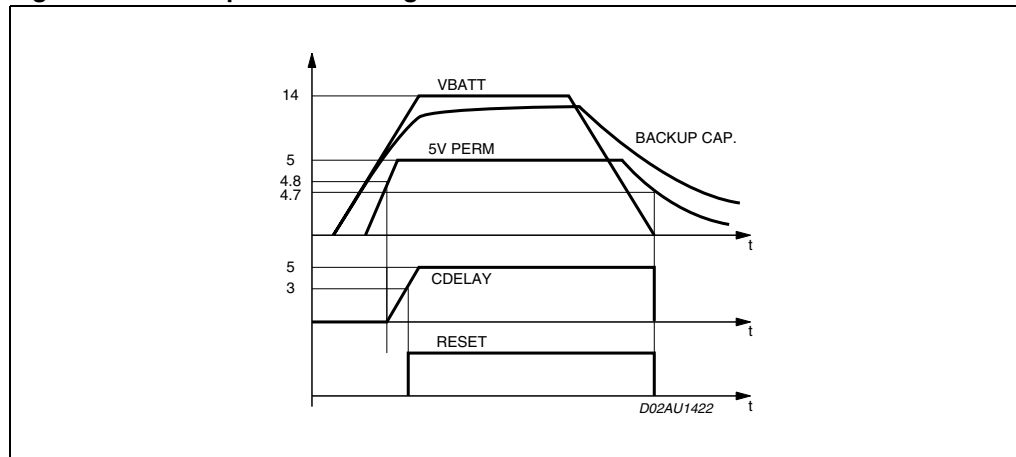
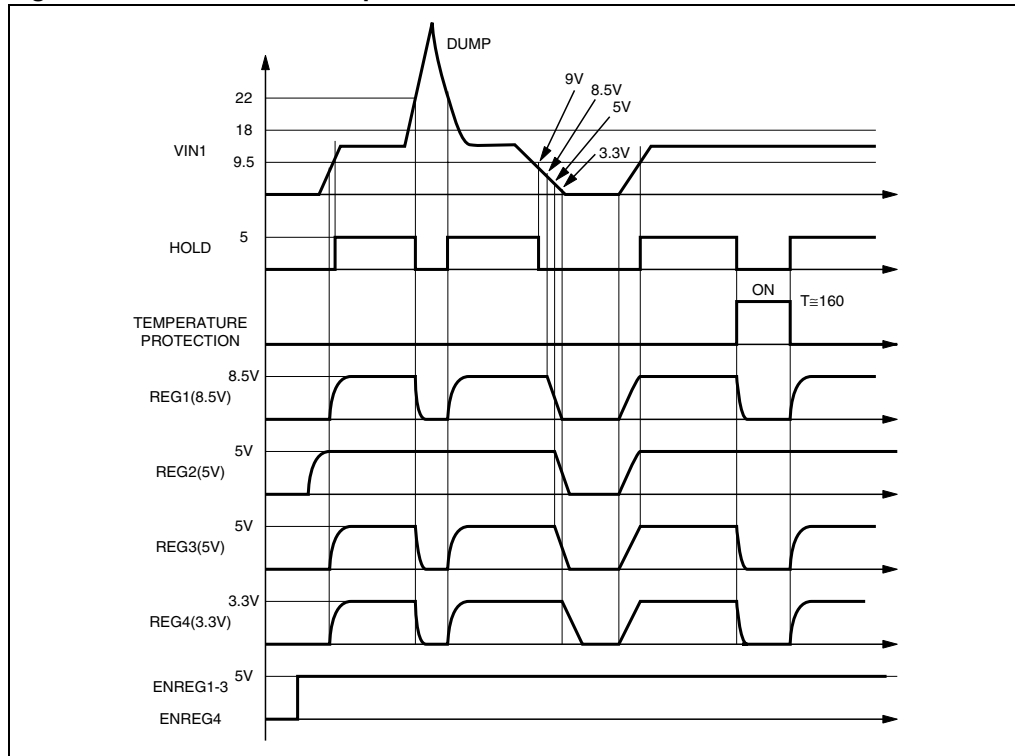

Figure 6. Backup and reset diagram



**Figure 7. Hold and thermal protection**



**Figure 8. Ignition buffer diagram**

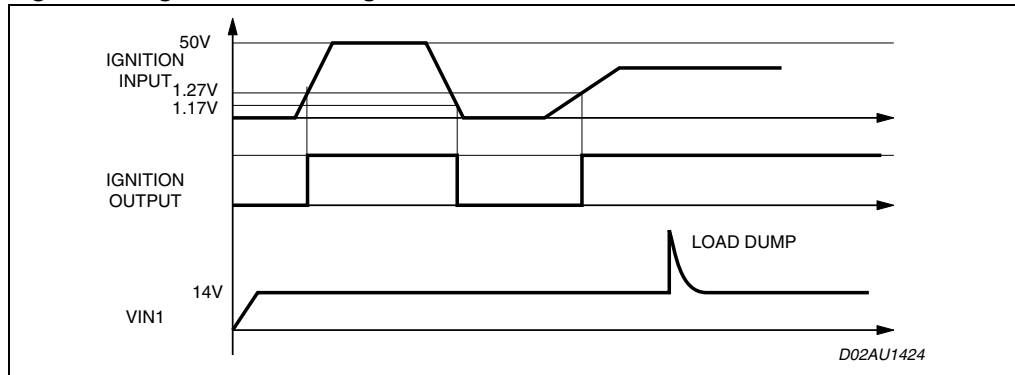

**Figure 9. Protection of the power switch**

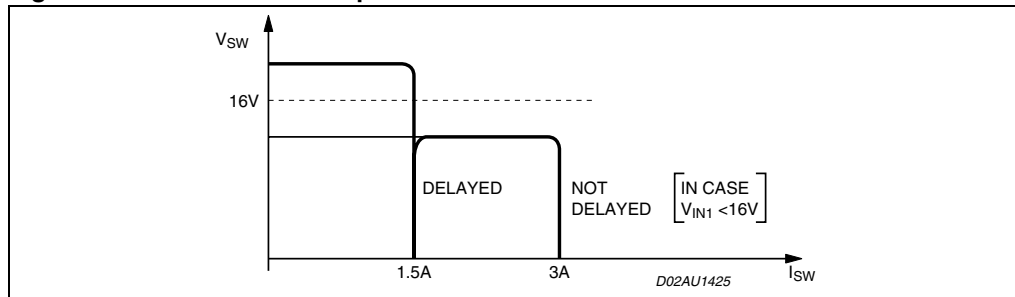
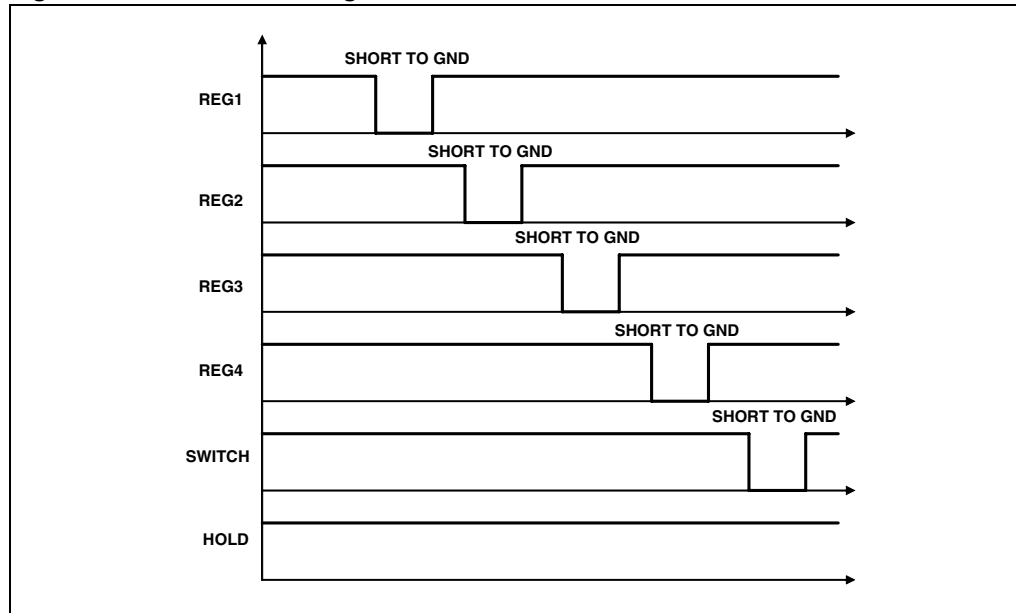

Figure 10. Short circuit diagram



# 4 Package information

In order to meet environmental requirements, ST offers these devices in different grades of ECOPACK® packages, depending on their level of environmental compliance. ECOPACK® specifications, grade definitions and product status are available at: [www.st.com](http://www.st.com).

ECOPACK® is an ST trademark.

**Figure 11. PowerSO20 (slug-up) mechanical data and package dimensions**

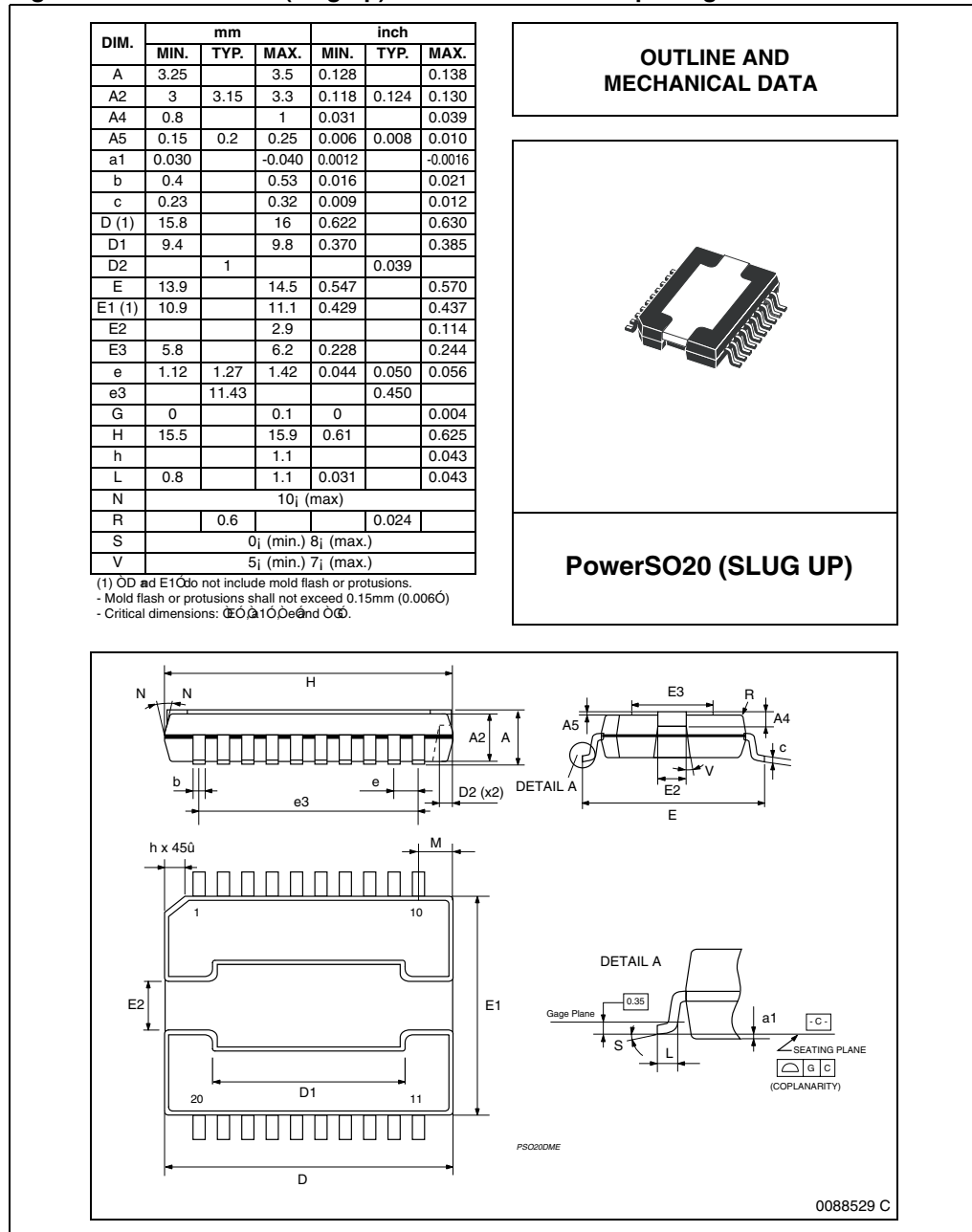
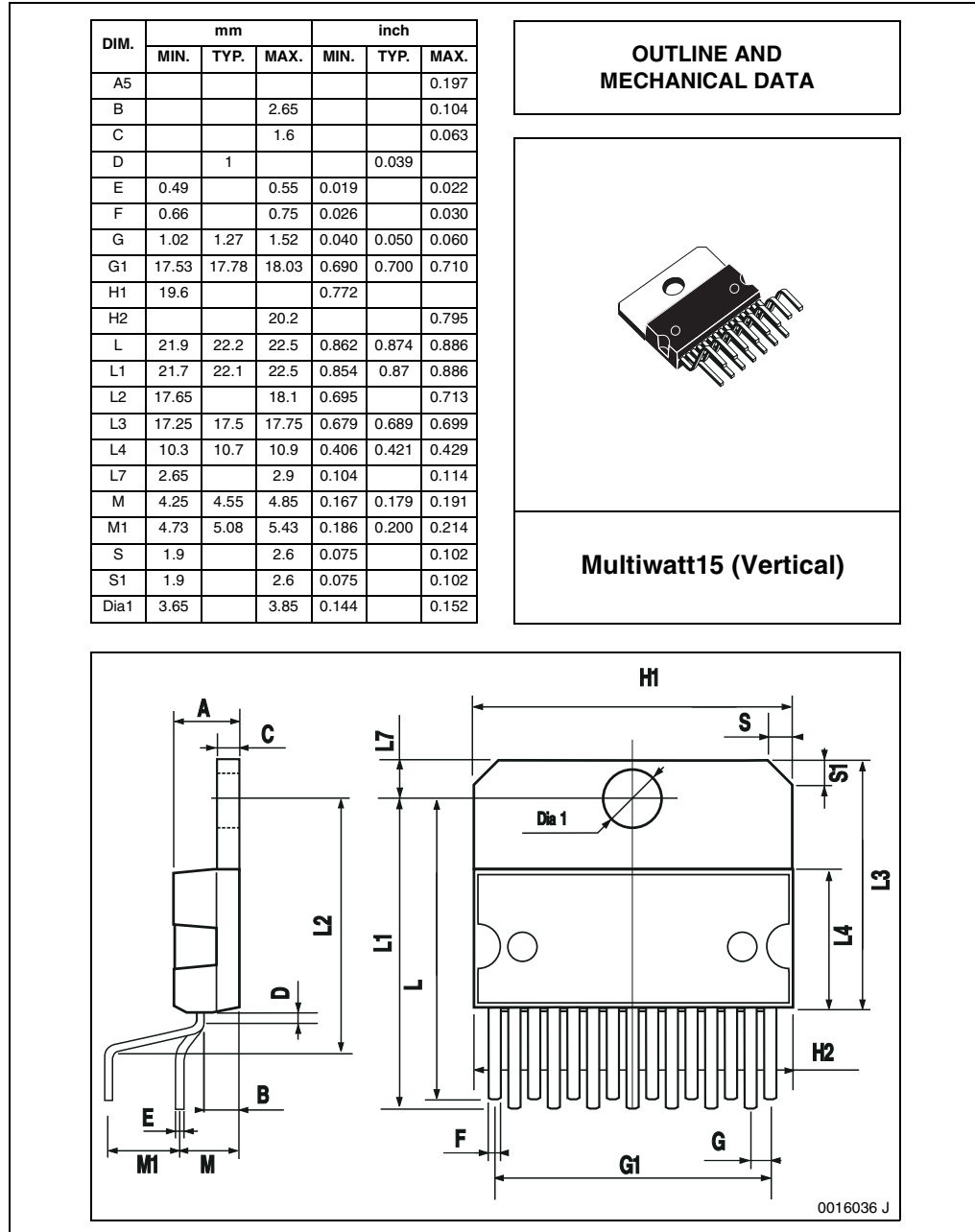

Figure 12. Multiwatt 15 (vertical) mechanical data and package dimensions



## 5 Revision history

Table 5. Document revision history

Date	Revision	Changes
29-Aug-2007	1	Initial release.
08-Jan-2010	2	Updated <i>Figure 1, 2, 3, 5</i> and <i>7</i> . Added <i>Figure 4: Maximum ESR for stability valid for all the regulators outputs on page 10</i> .



**Please Read Carefully:**

Information in this document is provided solely in connection with ST products. STMicroelectronics NV and its subsidiaries ("ST") reserve the right to make changes, corrections, modifications or improvements, to this document, and the products and services described herein at any time, without notice.

All ST products are sold pursuant to ST's terms and conditions of sale.

Purchasers are solely responsible for the choice, selection and use of the ST products and services described herein, and ST assumes no liability whatsoever relating to the choice, selection or use of the ST products and services described herein.

No license, express or implied, by estoppel or otherwise, to any intellectual property rights is granted under this document. If any part of this document refers to any third party products or services it shall not be deemed a license grant by ST for the use of such third party products or services, or any intellectual property contained therein or considered as a warranty covering the use in any manner whatsoever of such third party products or services or any intellectual property contained therein.

**UNLESS OTHERWISE SET FORTH IN ST'S TERMS AND CONDITIONS OF SALE ST DISCLAIMS ANY EXPRESS OR IMPLIED WARRANTY WITH RESPECT TO THE USE AND/OR SALE OF ST PRODUCTS INCLUDING WITHOUT LIMITATION IMPLIED WARRANTIES OF MERCHANTABILITY, FITNESS FOR A PARTICULAR PURPOSE (AND THEIR EQUIVALENTS UNDER THE LAWS OF ANY JURISDICTION), OR INFRINGEMENT OF ANY PATENT, COPYRIGHT OR OTHER INTELLECTUAL PROPERTY RIGHT.**

**UNLESS EXPRESSLY APPROVED IN WRITING BY AN AUTHORIZED ST REPRESENTATIVE, ST PRODUCTS ARE NOT RECOMMENDED, AUTHORIZED OR WARRANTED FOR USE IN MILITARY, AIR CRAFT, SPACE, LIFE SAVING, OR LIFE SUSTAINING APPLICATIONS, NOR IN PRODUCTS OR SYSTEMS WHERE FAILURE OR MALFUNCTION MAY RESULT IN PERSONAL INJURY, DEATH, OR SEVERE PROPERTY OR ENVIRONMENTAL DAMAGE. ST PRODUCTS WHICH ARE NOT SPECIFIED AS "AUTOMOTIVE GRADE" MAY ONLY BE USED IN AUTOMOTIVE APPLICATIONS AT USER'S OWN RISK.**

Resale of ST products with provisions different from the statements and/or technical features set forth in this document shall immediately void any warranty granted by ST for the ST product or service described herein and shall not create or extend in any manner whatsoever, any liability of ST.

ST and the ST logo are trademarks or registered trademarks of ST in various countries.

Information in this document supersedes and replaces all information previously supplied.

The ST logo is a registered trademark of STMicroelectronics. All other names are the property of their respective owners.

© 2010 STMicroelectronics - All rights reserved

STMicroelectronics group of companies

Australia - Belgium - Brazil - Canada - China - Czech Republic - Finland - France - Germany - Hong Kong - India - Israel - Italy - Japan - Malaysia - Malta - Morocco - Philippines - Singapore - Spain - Sweden - Switzerland - United Kingdom - United States of America

[www.st.com](http://www.st.com)

