

LP2997

DDR-II Termination Regulator

General Description

The LP2997 linear regulator is designed to meet the JEDEC SSTL-18 specifications for termination of DDR-II memory. The device contains a high-speed operational amplifier to provide excellent response to load transients. The output stage prevents shoot through while delivering 500mA continuous current and transient peaks up to 900mA in the application as required for DDR-II SDRAM termination. The LP2997 also incorporates a V_{SENSE} pin to provide superior load regulation and a V_{REF} output as a reference for the chipset and DIMMs.

An additional feature found on the LP2997 is an active low shutdown (\overline{SD}) pin that provides Suspend To RAM (STR) functionality. When \overline{SD} is pulled low the V_{TT} output will tri-state providing a high impedance output, but, V_{REF} will remain active. A power savings advantage can be obtained in this mode through lower quiescent current.

Features

- Source and sink current
- Low output voltage offset
- No external resistors required
- Linear topology
- Suspend to Ram (STR) functionality
- Low external component count
- Thermal Shutdown
- Available in SO-8, PSOP-8 packages

Applications

- DDR-II Termination Voltage
- SSTL-18 Termination

Typical Application Circuit

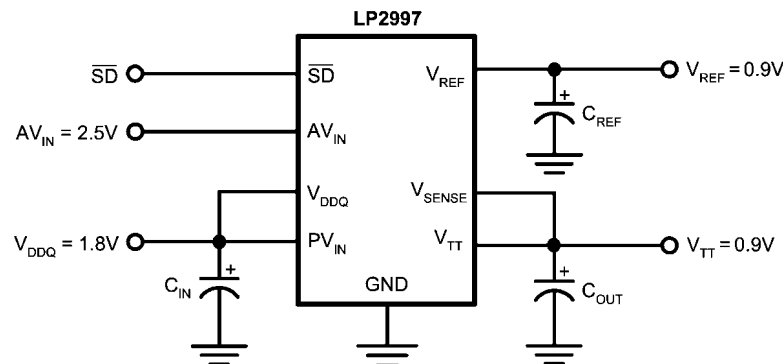

20109418

Connection Diagrams

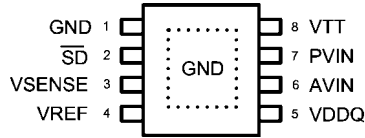

PSOP-8 Layout

20109403

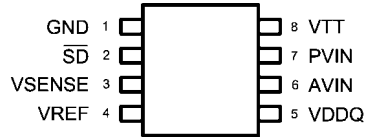

SO-8 Layout

20109404

Pin Descriptions

SO-8 Pin or PSOP-8 Pin	Name	Function
1	GND	Ground
2	\overline{SD}	Shutdown
3	VSENSE	Feedback pin for regulating V_{TT} .
4	VREF	Buffered internal reference voltage of $V_{DDQ}/2$
5	VDDQ	Input for internal reference equal to $V_{DDQ}/2$
6	AVIN	Analog input pin
7	PVIN	Power input pin
8	VTT	Output voltage for connection to termination resistors
	EP	Exposed pad thermal connection Connect to soft Ground

Ordering Information

Order Number	Package Type	NSC Package Drawing	Supplied As
LP2997M	SO-8	M08A	95 Units per Rail
LP2997MX	SO-8	M08A	2500 Units Tape and Reel
LP2997MR	PSOP-8	MRA08A	95 Units Tape and Reel
LP2997MRX	PSOP-8	MRA08A	2500 Units Tape and Reel

Absolute Maximum Ratings *(Note 1)*

If Military/Aerospace specified devices are required, please contact the National Semiconductor Sales Office/Distributors for availability and specifications.

AVIN to GND	-0.3V to +6V
PVIN to GND	-0.3V to AVIN
VDDQ <i>(Note 2)</i>	-0.3V to +6V
Storage Temp. Range	-65°C to +150°C
Junction Temperature	150°C

Lead Temperature (Soldering, 10 sec)	260°C
SO-8 Thermal Resistance (θ_{JA})	151°C/W
PSOP-8 Thermal Resistance (θ_{JA})	43°C/W
Minimum ESD Rating <i>(Note 3)</i>	1kV

Operating Range

Junction Temp. Range <i>(Note 4)</i>	0°C to +125°C
AVIN to GND	2.2V to 5.5V

Electrical Characteristics Specifications with standard typeface are for $T_J = 25^\circ\text{C}$ and limits in **boldface type** apply over the full **Operating Temperature Range** ($T_J = 0^\circ\text{C}$ to $+125^\circ\text{C}$) *(Note 5)*. Unless otherwise specified, AVIN = 2.5V, PVIN = 1.8V, VDDQ = 1.8V.

Symbol	Parameter	Conditions	Min	Typ	Max	Units
V_{REF}	V_{REF} Voltage	PVIN = VDDQ = 1.7V PVIN = VDDQ = 1.8V PVIN = VDDQ = 1.9V	0.837 0.887 0.936	0.860 0.910 0.959	0.887 0.937 0.986	V
Z_{VREF}	V_{REF} Output Impedance	$I_{REF} = -30$ to $+30 \mu\text{A}$		2.5		k Ω
V_{TT}	V_{TT} Output Voltage	$I_{OUT} = 0\text{A}$ PVIN = VDDQ = 1.7V PVIN = VDDQ = 1.8V PVIN = VDDQ = 1.9V $I_{OUT} = \pm 0.5\text{A}$ <i>(Note 8)</i> PVIN = VDDQ = 1.7V PVIN = VDDQ = 1.8V PVIN = VDDQ = 1.9V	0.822 0.874 0.923 0.828 0.878 0.928	0.856 0.908 0.957 0.856 0.908 0.957	0.887 0.939 0.988 0.890 0.940 0.990	V
$V_{OS_{TT}}/V_{TT}$	V_{TT} Output Voltage Offset ($V_{REF} - V_{TT}$)	$I_{OUT} = 0\text{A}$ $I_{OUT} = -0.5\text{A}$ $I_{OUT} = +0.5\text{A}$	-25 -25 -25	0 0 0	25 25 25	mV
I_Q	Quiescent Current <i>(Note 6)</i>	$I_{OUT} = 0\text{A}$ <i>(Note 6)</i>		320	500	μA
Z_{VDDQ}	VDDQ Input Impedance			100		k Ω
I_{SD}	Quiescent Current in Shutdown <i>(Note 6)</i>	SD = 0V		115	150	μA
I_{Q_SD}	Shutdown Leakage Current	SD = 0V		2	5	μA
V_{IH}	Minimum Shutdown High Level		1.9			V
V_{IL}	Maximum Shutdown Low Level				0.8	V
I_{SENSE}	V_{SENSE} Input Current			13		nA
T_{SD}	Thermal Shutdown	<i>(Note 7)</i>		165		Celsius
T_{SD_HYS}	Thermal Shutdown Hysteresis			10		Celsius

Note 1: Absolute maximum ratings indicate limits beyond which damage to the device may occur. Operating range indicates conditions for which the device is intended to be functional, but does not guarantee specific performance limits. For guaranteed specifications and test conditions see Electrical Characteristics. The guaranteed specifications apply only for the test conditions listed. Some performance characteristics may degrade when the device is not operated under the listed test conditions.

Note 2: VDDQ voltage must be less than $2 \times (AVIN - 1)$ or 6V, whichever is smaller.

Note 3: The human body model is a 100pF capacitor discharged through a 1.5k Ω resistor into each pin.

Note 4: At elevated temperatures, devices must be derated based on thermal resistance. The device in the SO-8 package must be derated at $\theta_{JA} = 151.2^\circ \text{C/W}$ junction to ambient with no heat sink.

Note 5: Limits are 100% production tested at 25°C. Limits over the operating temperature range are guaranteed through correlation using Statistical Quality Control (SQC) methods. The limits are used to calculate National's Average Outgoing Quality Level (AOQL).

Note 6: Quiescent current defined as the current flow into AVIN.

Note 7: The maximum allowable power dissipation is a function of the maximum junction temperature, $T_{J(MAX)}$, the junction to ambient thermal resistance, θ_{JA} , and the ambient temperature, T_A . Exceeding the maximum allowable power dissipation will cause excessive die temperature and the regulator will go into thermal shutdown.

Note 8: V_{TT} load regulation is tested by using a 10 ms current pulse and measuring V_{TT} .

Typical Performance Characteristics

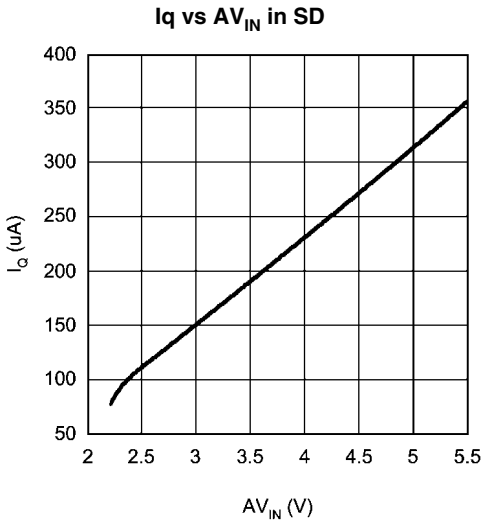

20109420

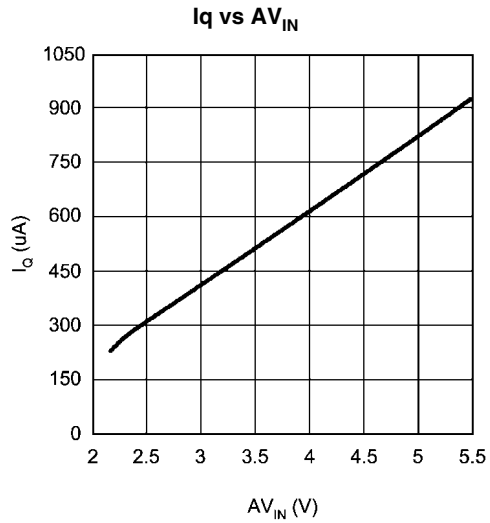

20109421

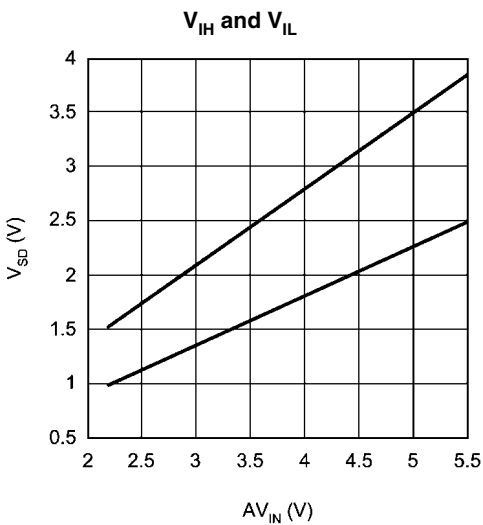

20109422

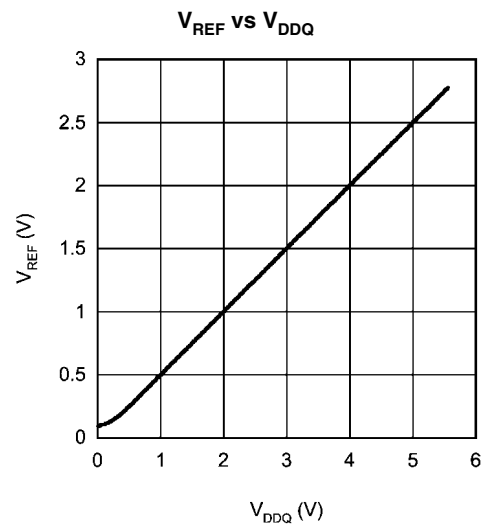

20109424

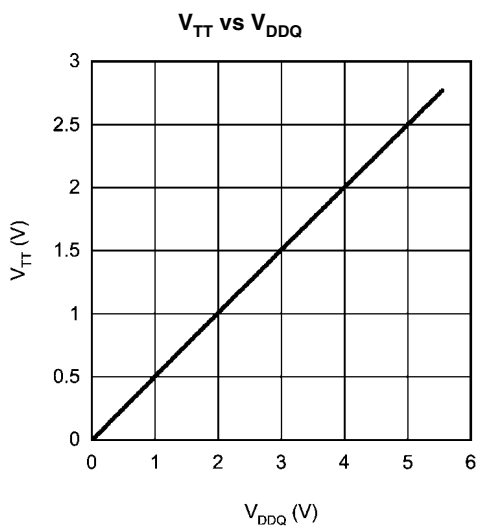

20109426

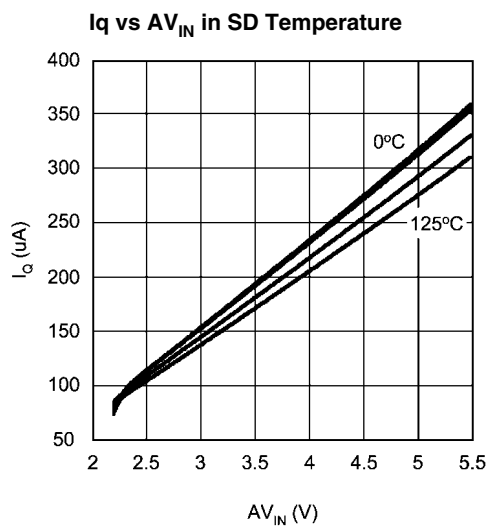

20109427

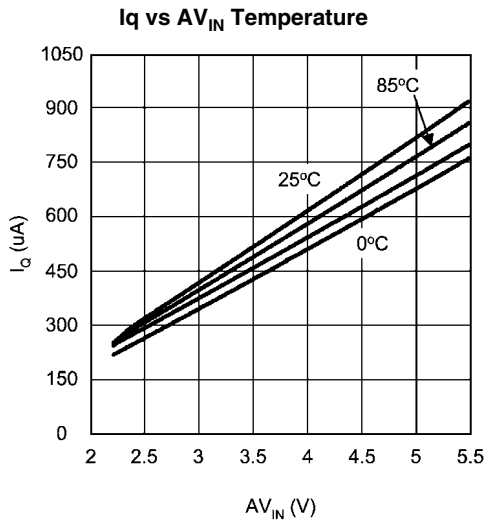

20109428

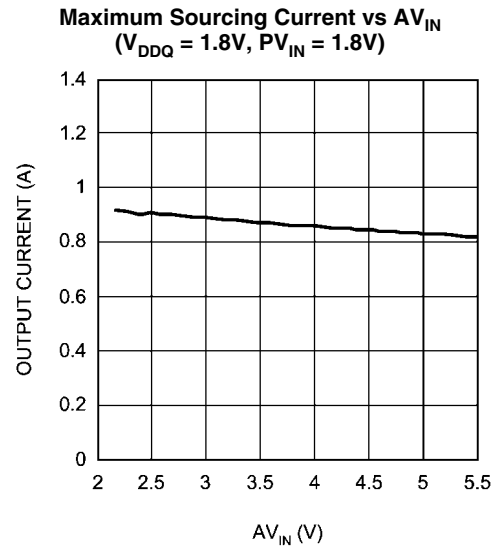

20109435

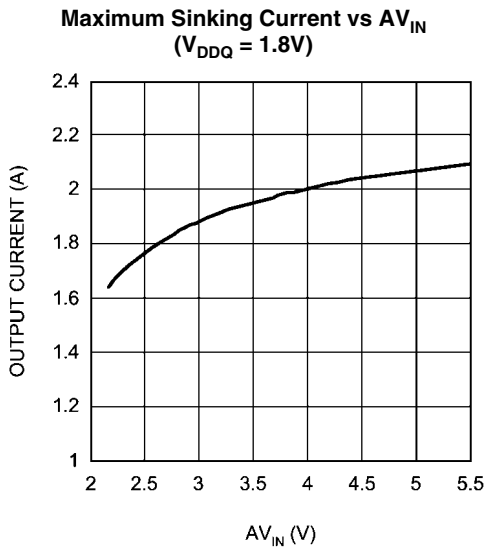

20109436

Block Diagram

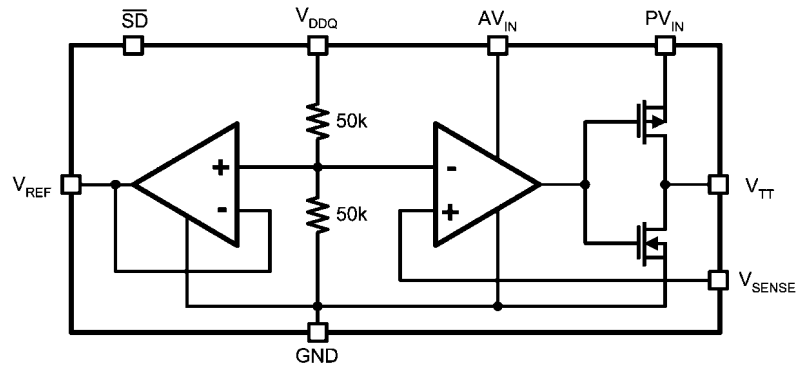

20109405

Description

The LP2997 is a linear bus termination regulator designed to meet the JEDEC requirements of SSTL-18. The output, V_{TT} is capable of sinking and sourcing current while regulating the output voltage equal to $V_{DDQ} / 2$. The output stage has been designed to maintain excellent load regulation while preventing shoot through. The LP2997 also incorporates two distinct power rails that separates the analog circuitry from the power output stage. This allows a split rail approach to be utilized to decrease internal power dissipation. It also permits the LP2997 to provide a termination solution for the next generation of DDR-SDRAM memory (DDRII).

Pin Descriptions

AVIN AND PVIN

AVIN and PVIN are the input supply pins for the LP2997. AVIN is used to supply all the internal control circuitry. PVIN, however, is used exclusively to provide the rail voltage for the output stage used to create V_{TT} . These pins have the capability to work off separate supplies, under the condition that AVIN is always greater than or equal to PVIN. For SSTL-18 applications, it is recommended to connect PVIN to the 1.8V rail used for the memory core and AVIN to a rail within its operating range of 2.2V to 5.5V (typically a 2.5V supply). PVIN should always be used with either a 1.8V or 2.5V rail. This prevents the thermal limit from tripping because of excessive internal power dissipation. If the junction temperature exceeds the thermal shutdown then the part will enter a shutdown state identical to the manual shutdown where V_{TT} is tri-stated and V_{REF} remains active. A lower rail such as 1.5V can be used but it will reduce the maximum output current, therefore it is not recommended for most termination schemes.

VDDQ

VDDQ is the input used to create the internal reference voltage for regulating V_{TT} . The reference voltage is generated from a resistor divider of two internal 50k Ω resistors. This guarantees that V_{TT} will track $V_{DDQ} / 2$ precisely. The optimal implementation of VDDQ is as a remote sense. This can be achieved by connecting VDDQ directly to the 1.8V rail at the DIMM instead of PVIN. This ensures that the reference voltage tracks the DDR memory rails precisely without a large voltage drop from the power lines. For SSTL-18 applications VDDQ will be a 1.8V signal, which will create a 0.9V termination voltage at V_{TT} (See Electrical Characteristics Table for exact values of V_{TT} over temperature).

V_{SENSE}

The purpose of the sense pin is to provide improved remote load regulation. In most motherboard applications the termination resistors will connect to V_{TT} in a long plane. If the output voltage was regulated only at the output of the LP2997 then the long trace will cause a significant IR drop resulting in a termination voltage lower at one end of the bus than the other. The V_{SENSE} pin can be used to improve this performance, by connecting it to the middle of the bus. This will provide a better distribution across the entire termination bus. If remote load regulation is not used then the V_{SENSE} pin must still be connected to V_{TT} . Care should be taken when a long V_{SENSE} trace is implemented in close proximity to the memory. Noise pick-up in the V_{SENSE} trace can cause problems with precise regulation of V_{TT} . A small 0.1 μ F ceramic capacitor placed next to the V_{SENSE} pin can help filter any high frequency signals and preventing errors.

SHUTDOWN

The LP2997 contains an active low shutdown pin that can be used for suspend to RAM functionality. In this condition the V_{TT} output will tri-state while the V_{REF} output remains active providing a constant reference signal for the memory and chipset. During shutdown V_{TT} should not be exposed to voltages that exceed PVIN. With the shutdown pin asserted low the quiescent current of the LP2997 will drop, however, VDDQ will always maintain its constant impedance of 100k Ω for generating the internal reference. Therefore, to calculate the total power loss in shutdown both currents need to be considered. For more information refer to the Thermal Dissipation section. The shutdown pin also has an internal pull-up current; therefore, to turn the part on the shutdown pin can either be connected to AVIN or left open

V_{REF}

V_{REF} provides the buffered output of the internal reference voltage $V_{DDQ} / 2$. This output should be used to provide the reference voltage for the Northbridge chipset and memory. Since these inputs are typically an extremely high impedance, there should be little current drawn from V_{REF} . For improved performance, an output bypass capacitor can be used, located close to the pin, to help with noise. A ceramic capacitor in the range of 0.1 μ F to 0.01 μ F is recommended. This output remains active during the shutdown state and thermal shutdown events for the suspend to RAM functionality.

V_{TT}

V_{TT} is the regulated output that is used to terminate the bus resistors. It is capable of sinking and sourcing current while regulating the output precisely to $V_{DDQ} / 2$. The LP2997 is designed to handle continuous currents of up to ± 0.5 A with excellent load regulation. If a transient is expected to last above the maximum continuous current rating for a significant amount of time, then the bulk output capacitor should be sized large enough to prevent an excessive voltage drop. If the LP2997 is to operate in elevated temperatures for long durations care should be taken to ensure that the maximum junction temperature is not exceeded. Proper thermal de-rating should always be used. (Please refer to the Thermal Dissipation section) If the junction temperature exceeds the thermal shutdown point than V_{TT} will tri-state until the part returns below the temperature hysteresis trip-point

Component Selections

INPUT CAPACITOR

The LP2997 does not require a capacitor for input stability, but it is recommended for improved performance during large load transients to prevent the input rail from dropping. The input capacitor should be located as close as possible to the PVIN pin. Several recommendations exist dependent on the application required. A typical value recommended for AL electrolytic capacitors is 22 μ F. Ceramic capacitors can also be used. A value in the range of 10 μ F with X5R or better would be an ideal choice. The input capacitance can be reduced if the LP2997 is placed close to the bulk capacitance from the output of the 1.8V DC-DC converter. For the AVIN pin, a small 0.1 μ F ceramic capacitor is sufficient to prevent excessive noise from coupling into the device.

OUTPUT CAPACITOR

The LP2997 has been designed to be insensitive of output capacitor size or ESR (Equivalent Series Resistance). This allows the flexibility to use any capacitor desired. The choice for output capacitor will be determined solely on the applica-

tion and the requirements for load transient response of V_{TT} . As a general recommendation the output capacitor should be sized above 100 μF with a low ESR for SSTL applications with DDR-SDRAM. The value of ESR should be determined by the maximum current spikes expected and the extent at which the output voltage is allowed to droop. Several capacitor options are available on the market and a few of these are highlighted below:

AL - It should be noted that many aluminum electrolytics only specify impedance at a frequency of 120 Hz, which indicates they have poor high frequency performance. Only aluminum electrolytics that have an impedance specified at a higher frequency (100 kHz) should be used for the LP2997. To improve the ESR several AL electrolytics can be combined in parallel for an overall reduction. An important note to be aware of is the extent at which the ESR will change over temperature. Aluminum electrolytic capacitors can have their ESR rapidly increase at cold temperatures.

Ceramic - Ceramic capacitors typically have a low capacitance, in the range of 10 to 100 μF range, but they have excellent AC performance for bypassing noise because of very low ESR (typically less than 10 m Ω). However, some dielectric types do not have good capacitance characteristics as a function of voltage and temperature. Because of the typically low value of capacitance it is recommended to use ceramic capacitors in parallel with another capacitor such as an aluminum electrolytic. A dielectric of X5R or better is recommended for all ceramic capacitors.

Hybrid - Several hybrid capacitors such as OS-CON and SP are available from several manufacturers. These offer a large capacitance while maintaining a low ESR. These are the best solution when size and performance are critical, although their cost is typically higher than any other capacitors.

Thermal Dissipation

Since the LP2997 is a linear regulator any current flow from V_{TT} will result in internal power dissipation generating heat. To prevent damaging the part from exceeding the maximum allowable junction temperature, care should be taken to derate the part dependent on the maximum expected ambient temperature and power dissipation. The maximum allowable internal temperature rise (T_{Rmax}) can be calculated given the maximum ambient temperature (T_{Amax}) of the application and the maximum allowable junction temperature (T_{Jmax}).

$$T_{Rmax} = T_{Jmax} - T_{Amax}$$

From this equation, the maximum power dissipation (P_{Dmax}) of the part can be calculated:

$$P_{Dmax} = T_{Rmax} / \theta_{JA}$$

The θ_{JA} of the LP2997 will be dependent on several variables: the package used; the thickness of copper; the number of vias and the airflow. For instance, the θ_{JA} of the SO-8 is 163°C/W with the package mounted to a standard 8x4 2-layer board with 1oz. copper, no airflow, and 0.5W dissipation at room temperature. This value can be reduced to 151.2°C/W by changing to a 3x4 board with 2 oz. copper that is the JEDEC standard. *Figure 1* shows how the θ_{JA} varies with airflow for the two boards mentioned.

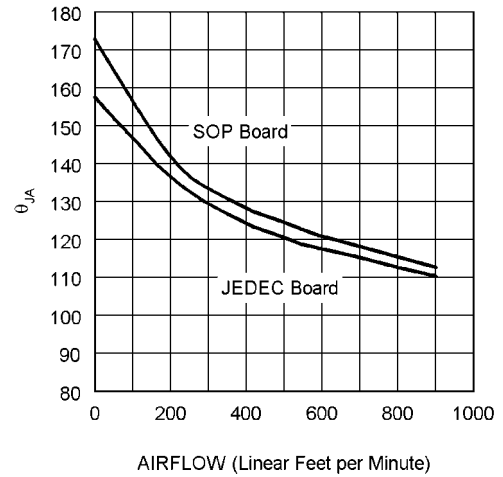

20109407

FIGURE 1. θ_{JA} vs Airflow (SO-8)

Additional improvements can be made by the judicious use of vias to connect the part and dissipate heat to an internal ground plane. Using larger traces and more copper on the top side of the board can also help. With careful layout it is possible to reduce the θ_{JA} further than the nominal values shown in *Figure 1*

Optimizing the θ_{JA} and placing the LP2997 in a section of a board exposed to lower ambient temperature allows the part to operate with higher power dissipation. The internal power dissipation can be calculated by summing the three main sources of loss: output current at V_{TT} , either sinking or sourcing, and quiescent current at AVIN and VDDQ. During the active state (when shutdown is not held low) the total internal power dissipation can be calculated from the following equations:

$$P_D = P_{AVIN} + P_{VDDQ} + P_{VTT}$$

Where,

$$P_{AVIN} = I_{AVIN} * V_{AVIN}$$

$$P_{VDDQ} = V_{VDDQ} * I_{VDDQ} = V_{VDDQ}^2 * R_{VDDQ}$$

To calculate the maximum power dissipation at V_{TT} both conditions at V_{TT} need to be examined, sinking and sourcing current. Although only one equation will add into the total, V_{TT} cannot source and sink current simultaneously.

$$P_{VTT} = V_{VTT} * I_{LOAD} \text{ (Sinking) or}$$

$$P_{VTT} = (V_{PVIN} - V_{VTT}) * I_{LOAD} \text{ (Sourcing)}$$

The power dissipation of the LP2997 can also be calculated during the shutdown state. During this condition the output V_{TT} will tri-state, therefore that term in the power equation will disappear as it cannot sink or source any current (leakage is negligible). The only losses during shutdown will be the reduced quiescent current at AVIN and the constant impedance that is seen at the VDDQ pin.

$$P_D = P_{AVIN} + P_{VDDQ}$$

$$P_{AVIN} = I_{AVIN} * V_{AVIN}$$

$$P_{VDDQ} = V_{VDDQ} * I_{VDDQ} = V_{VDDQ}^2 * R_{VDDQ}$$

Typical Application Circuits

Several different application circuits have been shown to illustrate some of the options that are possible in configuring the LP2997. Graphs of the individual circuit performance can be found in the *Typical Performance Characteristics* section in the beginning of the datasheet. These curves illustrate how the maximum output current is affected by changes in AVIN and PVIN.

Figure 2 shows the recommended circuit configuration for DDR-II applications. The output stage is connected to the 1.8V rail and the AVIN pin can be connected to either a 2.5V, 3.3V or 5V rail.

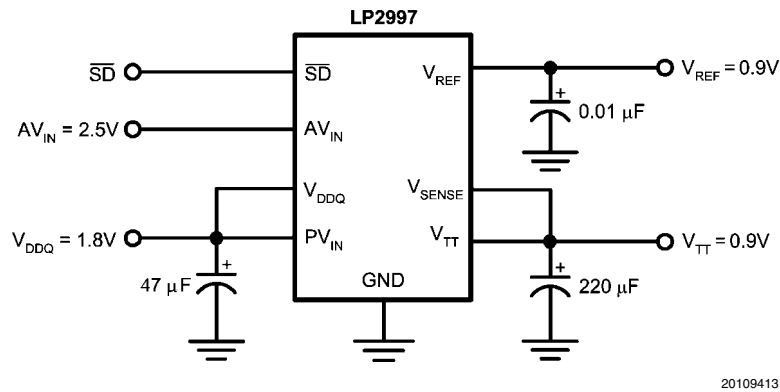
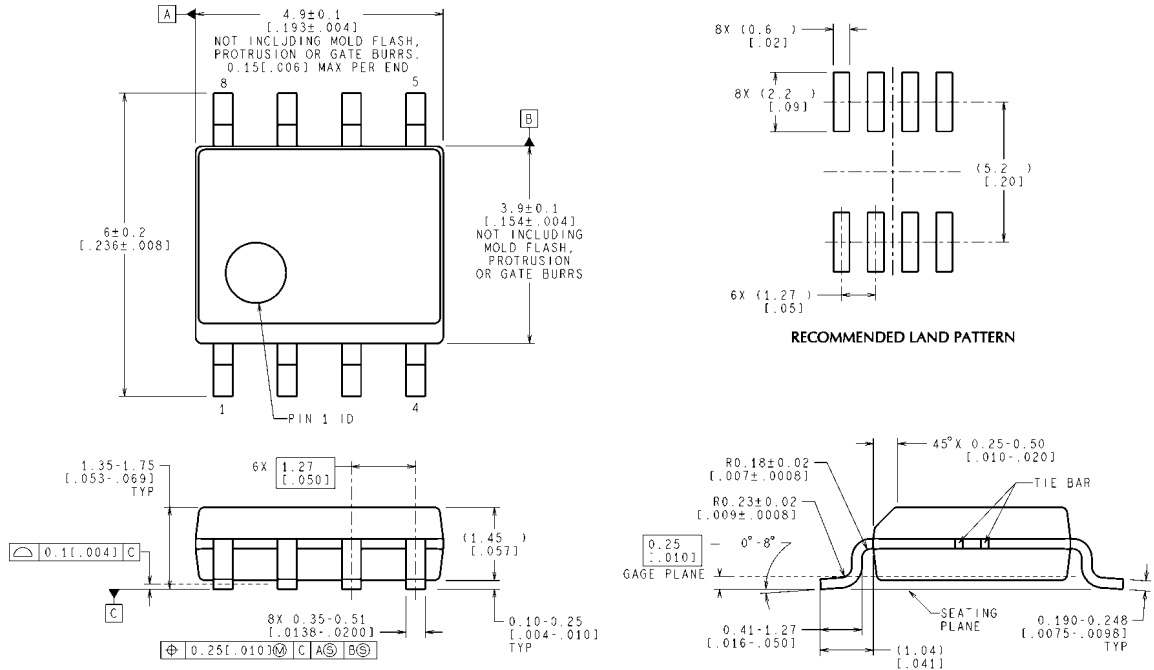

FIGURE 2. Recommended DDR-II Termination

PCB Layout Considerations

1. The input capacitor for the power rail should be placed as close as possible to the PVIN pin.
2. V_{SENSE} should be connected to the V_{TT} termination bus at the point where regulation is required. For motherboard applications an ideal location would be at the center of the termination bus.
3. V_{DDQ} can be connected remotely to the V_{DDQ} rail input at either the DIMM or the Chipset. This provides the most accurate point for creating the reference voltage.
4. For improved thermal performance excessive top side copper should be used to dissipate heat from the package. Numerous vias from the ground connection to the internal ground plane will help. Additionally these can be located underneath the package if manufacturing standards permit.
5. Care should be taken when routing the V_{SENSE} trace to avoid noise pickup from switching I/O signals. A 0.1µF ceramic capacitor located close to the V_{SENSE} can also be used to filter any unwanted high frequency signal. This can be an issue especially if long V_{SENSE} traces are used.
6. V_{REF} should be bypassed with a 0.01 µF or 0.1 µF ceramic capacitor for improved performance. This capacitor should be located as close as possible to the V_{REF} pin.

Physical Dimensions inches (millimeters) unless otherwise noted



CONTROLLING DIMENSION IS MILLIMETER
VALUES IN [] ARE INCHES
DIMENSIONS IN () FOR REFERENCE ONLY

8-Lead Small Outline Package (M8)
NS Package Number M08A

M08A (Rev M)

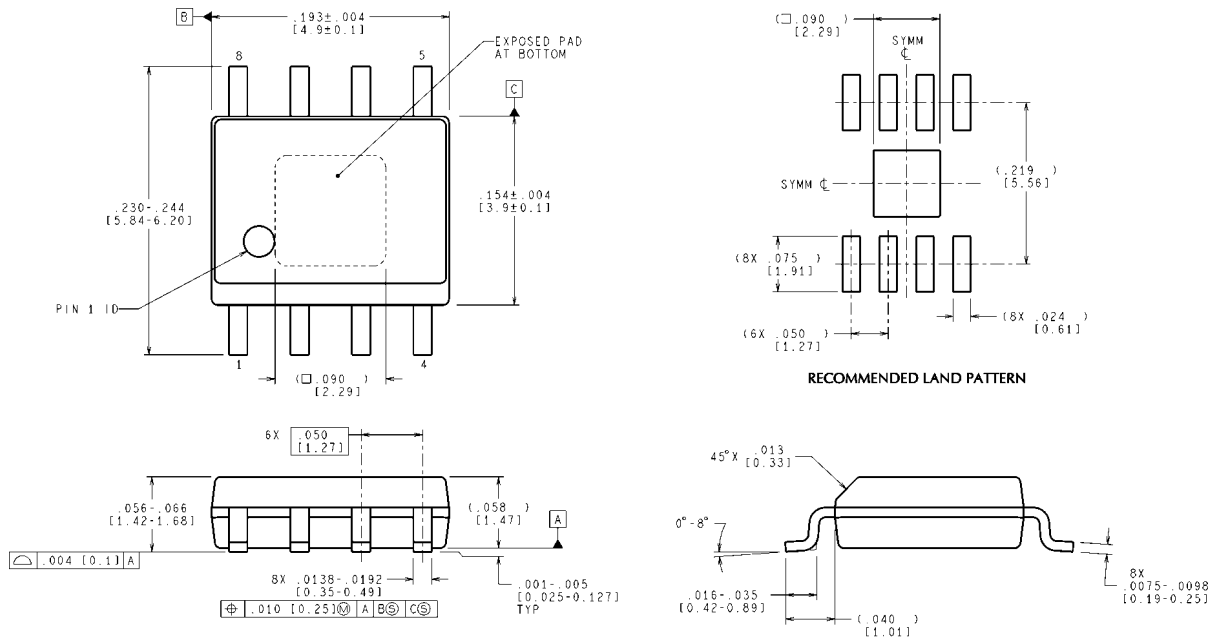

CONTROLLING DIMENSION IS INCH
VALUES IN [] ARE MILLIMETERS
DIMENSIONS IN () FOR REFERENCE ONLY

8-Lead PSOP Package (PSOP-8)
NS Package Number MRA08A

MRA08A (Rev D)

Notes

LP2997

Notes

For more National Semiconductor product information and proven design tools, visit the following Web sites at:
www.national.com

Products		Design Support	
Amplifiers	www.national.com/amplifiers	WEBENCH® Tools	www.national.com/webench
Audio	www.national.com/audio	App Notes	www.national.com/appnotes
Clock and Timing	www.national.com/timing	Reference Designs	www.national.com/refdesigns
Data Converters	www.national.com/adc	Samples	www.national.com/samples
Interface	www.national.com/interface	Eval Boards	www.national.com/evalboards
LVDS	www.national.com/lvds	Packaging	www.national.com/packaging
Power Management	www.national.com/power	Green Compliance	www.national.com/quality/green
Switching Regulators	www.national.com/switchers	Distributors	www.national.com/contacts
LDOs	www.national.com/ldo	Quality and Reliability	www.national.com/quality
LED Lighting	www.national.com/led	Feedback/Support	www.national.com/feedback
Voltage References	www.national.com/vref	Design Made Easy	www.national.com/easy
PowerWise® Solutions	www.national.com/powerwise	Applications & Markets	www.national.com/solutions
Serial Digital Interface (SDI)	www.national.com/sdi	Mil/Aero	www.national.com/milaero
Temperature Sensors	www.national.com/tempensors	SolarMagic™	www.national.com/solarmagic
PLL/VCO	www.national.com/wireless	PowerWise® Design University	www.national.com/training

THE CONTENTS OF THIS DOCUMENT ARE PROVIDED IN CONNECTION WITH NATIONAL SEMICONDUCTOR CORPORATION ("NATIONAL") PRODUCTS. NATIONAL MAKES NO REPRESENTATIONS OR WARRANTIES WITH RESPECT TO THE ACCURACY OR COMPLETENESS OF THE CONTENTS OF THIS PUBLICATION AND RESERVES THE RIGHT TO MAKE CHANGES TO SPECIFICATIONS AND PRODUCT DESCRIPTIONS AT ANY TIME WITHOUT NOTICE. NO LICENSE, WHETHER EXPRESS, IMPLIED, ARISING BY ESTOPPEL OR OTHERWISE, TO ANY INTELLECTUAL PROPERTY RIGHTS IS GRANTED BY THIS DOCUMENT.

TESTING AND OTHER QUALITY CONTROLS ARE USED TO THE EXTENT NATIONAL DEEMS NECESSARY TO SUPPORT NATIONAL'S PRODUCT WARRANTY. EXCEPT WHERE MANDATED BY GOVERNMENT REQUIREMENTS, TESTING OF ALL PARAMETERS OF EACH PRODUCT IS NOT NECESSARILY PERFORMED. NATIONAL ASSUMES NO LIABILITY FOR APPLICATIONS ASSISTANCE OR BUYER PRODUCT DESIGN. BUYERS ARE RESPONSIBLE FOR THEIR PRODUCTS AND APPLICATIONS USING NATIONAL COMPONENTS. PRIOR TO USING OR DISTRIBUTING ANY PRODUCTS THAT INCLUDE NATIONAL COMPONENTS, BUYERS SHOULD PROVIDE ADEQUATE DESIGN, TESTING AND OPERATING SAFEGUARDS.

EXCEPT AS PROVIDED IN NATIONAL'S TERMS AND CONDITIONS OF SALE FOR SUCH PRODUCTS, NATIONAL ASSUMES NO LIABILITY WHATSOEVER, AND NATIONAL DISCLAIMS ANY EXPRESS OR IMPLIED WARRANTY RELATING TO THE SALE AND/OR USE OF NATIONAL PRODUCTS INCLUDING LIABILITY OR WARRANTIES RELATING TO FITNESS FOR A PARTICULAR PURPOSE, MERCHANTABILITY, OR INFRINGEMENT OF ANY PATENT, COPYRIGHT OR OTHER INTELLECTUAL PROPERTY RIGHT.

LIFE SUPPORT POLICY

NATIONAL'S PRODUCTS ARE NOT AUTHORIZED FOR USE AS CRITICAL COMPONENTS IN LIFE SUPPORT DEVICES OR SYSTEMS WITHOUT THE EXPRESS PRIOR WRITTEN APPROVAL OF THE CHIEF EXECUTIVE OFFICER AND GENERAL COUNSEL OF NATIONAL SEMICONDUCTOR CORPORATION. As used herein:

Life support devices or systems are devices which (a) are intended for surgical implant into the body, or (b) support or sustain life and whose failure to perform when properly used in accordance with instructions for use provided in the labeling can be reasonably expected to result in a significant injury to the user. A critical component is any component in a life support device or system whose failure to perform can be reasonably expected to cause the failure of the life support device or system or to affect its safety or effectiveness.

National Semiconductor and the National Semiconductor logo are registered trademarks of National Semiconductor Corporation. All other brand or product names may be trademarks or registered trademarks of their respective holders.

Copyright© 2010 National Semiconductor Corporation

For the most current product information visit us at www.national.com



National Semiconductor Americas Technical Support Center
 Email: support@nsc.com
 Tel: 1-800-272-9959

National Semiconductor Europe Technical Support Center
 Email: europe.support@nsc.com

National Semiconductor Asia Pacific Technical Support Center
 Email: ap.support@nsc.com

National Semiconductor Japan Technical Support Center
 Email: jpn.feedback@nsc.com