

## LM4431 Micropower Shunt Voltage Reference

### General Description

Ideal for space critical applications, the LM4431 voltage reference is available in the sub-miniature (3 mm x 1.3 mm) SOT-23 surface-mount package. The LM4431's advanced design eliminates the need for an external stabilizing capacitor while ensuring stability with any capacitive load, thus making the LM4431 easy to use. The operating current range is 100  $\mu$ A to 15 mA.

The LM4431 utilizes fuse and zener-zap reverse breakdown voltage trim during wafer sort to ensure that the parts have an accuracy of better than  $\pm 2.0\%$  at 25°C. Bandgap reference temperature drift curvature correction and low dynamic impedance ensure stable reverse breakdown voltage accuracy over a wide range of operating temperatures and currents.

### Features

- Small package: SOT-23
- No output capacitor required

- Tolerates capacitive loads
- Fixed reverse breakdown voltage of 2.50V

### Key Specifications

- Output voltage tolerance 25°C:  $\pm 2.0\%$  (max)
- Low output noise (10 Hz to 10 kHz): 35  $\mu$ V<sub>rms</sub> (typ)
- Wide operating current range: 100  $\mu$ A to 15 mA
- Commercial temperature range: 0°C to +70°C
- Low temperature coefficient: 30 ppm/°C (typ)

### Applications

- Portable, Battery-Powered Equipment
- Data Acquisition Systems
- Instrumentation
- Process Control
- Energy Management
- Product Testing
- Power Supplies

### Connection Diagram

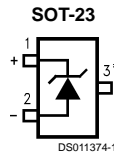

\* This pin must be left floating or connected to pin 2.

Top View  
Order Number LM4431M3-2.5  
See NS Package Number M03B  
(JEDEC Registration TO-236AB)

### SOT-23 Package Marking Information

Only three fields of marking are possible on the SOT-23's small surface. The following table gives the meaning of the three fields.

Part Marking	Field Definition
S2E	First Field: S = Reference Second Field: 2 = 2.500V Voltage Option Third Field: E = Initial Reverse Breakdown Voltage Tolerance of $\pm 2.0\%$

## Absolute Maximum Ratings (Note 1)

If Military/Aerospace specified devices are required, please contact the National Semiconductor Sales Office/Distributors for availability and specifications.

Reverse Current	20 mA
Forward Current	10 mA
Power Dissipation ( $T_A = 25^\circ\text{C}$ ) (Note 2)	
M3 Package	306 mW
Storage Temperature	$-65^\circ\text{C}$ to $+150^\circ\text{C}$
Lead Temperature	
M3 Package	
Vapor phase (60 seconds)	$+215^\circ\text{C}$
Infrared (15 seconds)	$+220^\circ\text{C}$

## ESD Susceptibility

Human Body Model (Note 3)	2 kV
Machine Model (Note 3)	200V

See AN-450 "Surface Mounting Methods and Their Effect on Product Reliability" for other methods of soldering surface mount devices.

## Operating Ratings (Notes 1, 2)

Temperature Range	$0^\circ\text{C} \leq T_A \leq +70^\circ\text{C}$
( $T_{\min} \leq T_A \leq T_{\max}$ )	
Reverse Current	
LM4431-2.5	100 $\mu\text{A}$ to 15 mA

## LM4431-2.5

### Electrical Characteristics

Boldface limits apply for  $T_A = T_J = T_{\min}$  to  $T_{\max}$ ; all other limits  $T_A = T_J = 25^\circ\text{C}$ .

Symbol	Parameter	Conditions	Typical (Note 4)	LM4431M3 Limits (Note 5)	Units (Limit)
$V_R$	Reverse Breakdown Voltage	$I_R = 100 \mu\text{A}$	2.500		V
	Reverse Breakdown Voltage Tolerance	$I_R = 100 \mu\text{A}$		$\pm 50$	mV (max)
$I_{R\min}$	Minimum Operating Current		45	<b>100</b>	$\mu\text{A}$ $\mu\text{A}$ (max)
$\Delta V_R/\Delta T$	Average Reverse Breakdown Voltage Temperature Coefficient	$I_R = 10 \text{ mA}$	$\pm 30$		ppm/ $^\circ\text{C}$
		$I_R = 1 \text{ mA}$	$\pm 30$		ppm/ $^\circ\text{C}$
		$I_R = 100 \mu\text{A}$	$\pm 30$		ppm/ $^\circ\text{C}$
$\Delta V_R/\Delta I_R$	Reverse Breakdown Voltage Change with Operating Current Change	$I_{R\min} \leq I_R \leq 1 \text{ mA}$	0.4	1.0 <b>1.2</b>	mV mV (max) mV (max)
		$1 \text{ mA} \leq I_R \leq 15 \text{ mA}$	2.5	8.0 <b>25</b>	mV mV (max) mV (max)
$Z_R$	Reverse Dynamic Impedance	$I_R = 1 \text{ mA}$ , $f = 120 \text{ Hz}$ $I_{AC} = 0.1 I_R$	1.0		$\Omega$
$e_N$	Wideband Noise	$I_R = 100 \mu\text{A}$ $10 \text{ Hz} \leq f \leq 10 \text{ kHz}$	35		$\mu\text{V}_{\text{rms}}$
$\Delta V_R$	Reverse Breakdown Voltage Long Term Stability	$t = 1000 \text{ hrs}$ $T = 25^\circ\text{C} \pm 0.1^\circ\text{C}$ $I_R = 100 \mu\text{A}$	120		ppm

**Note 1:** Absolute Maximum Ratings indicate limits beyond which damage to the device may occur. Operating Ratings indicate conditions for which the device is functional, but do not guarantee specific performance limits. For guaranteed specifications and test conditions, see the Electrical Characteristics. The guaranteed specifications apply only for the test conditions listed. Some performance characteristics may degrade when the device is not operated under the listed test conditions.

**Note 2:** The maximum power dissipation must be derated at elevated temperatures and is dictated by  $T_{J\max}$  (maximum junction temperature),  $\theta_{JA}$  (junction to ambient thermal resistance), and  $T_A$  (ambient temperature). The maximum allowable power dissipation at any temperature is  $PD_{\max} = (T_{J\max} - T_A)/\theta_{JA}$  or the number given in the Absolute Maximum Ratings, whichever is lower. For the LM4431,  $T_{J\max} = 125^\circ\text{C}$ , and the typical thermal resistance ( $\theta_{JA}$ ), when board mounted, is  $326^\circ\text{C}/\text{W}$  for the SOT-23 package.

**Note 3:** The human body model is a 100 pF capacitor discharged through a 1.5 k $\Omega$  resistor into each pin. The machine model is a 200 pF capacitor discharged directly into each pin.

**Note 4:** Typical values are at  $T_J = 25^\circ\text{C}$  and represent most likely parametric norm.

**Note 5:** Limits are 100% production tested at  $25^\circ\text{C}$ . Limits over temperature are guaranteed through correlation using Statistical Quality Control (SQC) methods. The limits are used to calculate National's AOQL.

## Typical Performance Characteristics

Temperature Drift for Different Average Temperature Coefficient

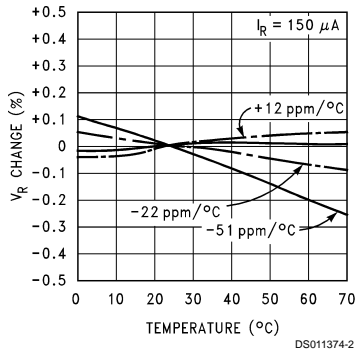

Output Impedance vs Frequency

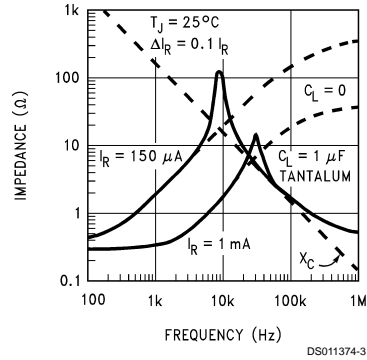

Reverse Characteristics and Minimum Operating Current

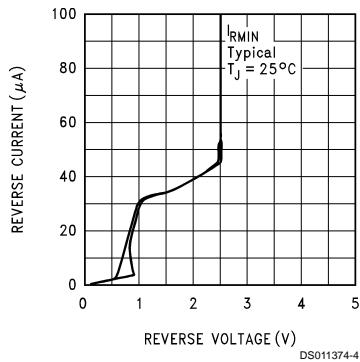

Noise Voltage

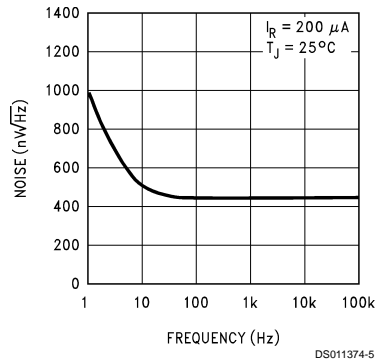

## Start-Up Characteristics

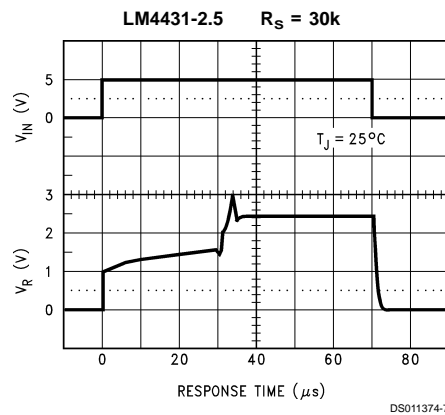
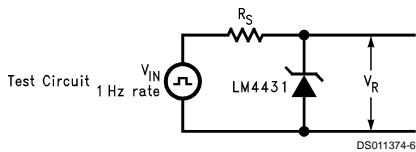

## Functional Block Diagram

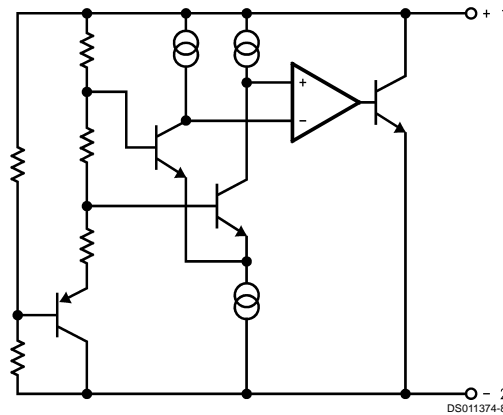

## Applications Information

The LM4431 is a micro-power curvature-corrected 2.5V bandgap shunt voltage reference. For space critical applications, the LM4431 is available in the sub-miniature SOT-23 surface-mount package. The LM4431 has been designed for stable operation without the need of an external capacitor connected between the "+" pin and the "-" pin. If, however, a bypass capacitor is used, the LM4431 remains stable. The operating current range is 100  $\mu$ A to 15 mA.

The LM4431's SOT-23 package has a parasitic Schottky diode between pin 2 (-) and pin 3 (Die attach interface contact). Therefore, pin 3 of the SOT-23 package must be left floating or connected to pin 2.

In a conventional shunt regulator application (Figure 1), an external series resistor ( $R_S$ ) is connected between the supply voltage and the LM4431.  $R_S$  determines the current that

flows through the load ( $I_L$ ) and the LM4431 ( $I_Q$ ). Since load current and supply voltage may vary,  $R_S$  should be small enough to supply at least the minimum acceptable  $I_Q$  to the LM4431 even when the supply voltage is at its minimum and the load current is at its maximum value. When the supply voltage is at its maximum and  $I_L$  is at its minimum,  $R_S$  should be large enough so that the current flowing through the LM4431 is less than 15 mA.

$R_S$  is determined by the supply voltage, ( $V_S$ ), the load and operating current, ( $I_L$  and  $I_Q$ ), and the LM4431's reverse breakdown voltage,  $V_R$ .

$$R_S = \frac{V_S - V_R}{I_L + I_Q}$$

## Typical Applications

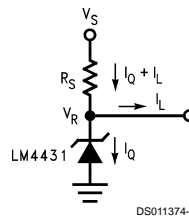
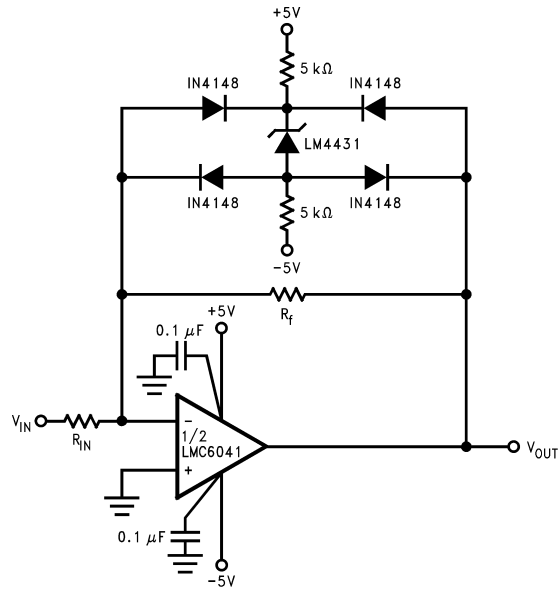

FIGURE 1. Shunt Regulator

## Typical Applications (Continued)



DS011374-10

**FIGURE 2. Bounded amplifier reduces saturation-induced delays and can prevent succeeding stage damage. Nominal clamping voltage is  $\pm 3.9\text{V}$  (LM4431's reverse breakdown voltage + 2 diode  $V_F$ ).**

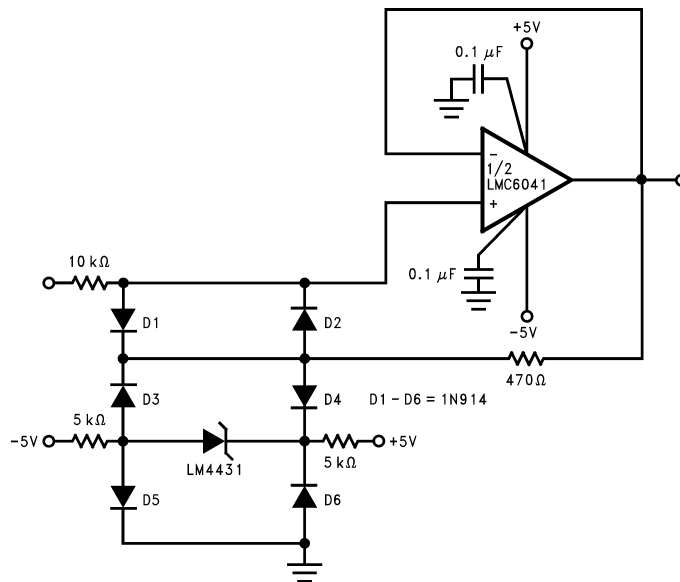

DS011374-11

**FIGURE 3. Protecting Op Amp input. The bounding voltage is  $\pm 4\text{V}$  with the LM4431 (LM4431's reverse breakdown voltage + 3 diode  $V_F$ ).**

## Typical Applications (Continued)

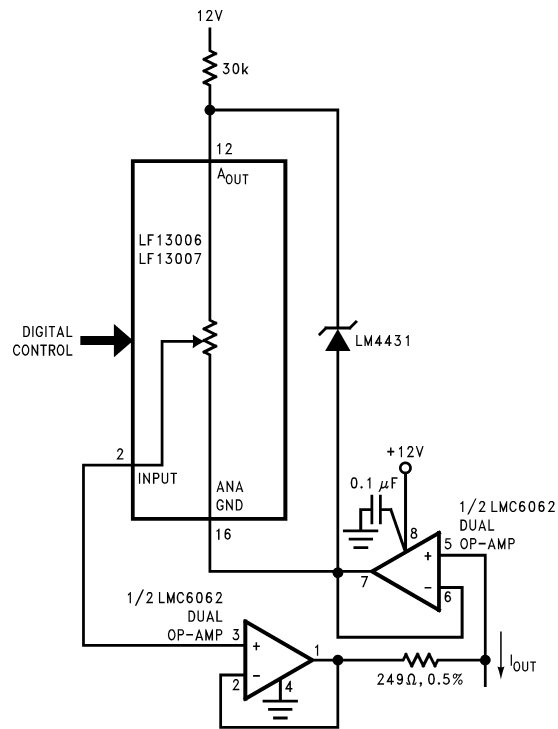

DS011374-12

$$I_{OUT} = \frac{2.5V}{249\Omega} \left[ \frac{1}{\text{gain set \#}} \right]$$

FIGURE 4. Programmable Current Source

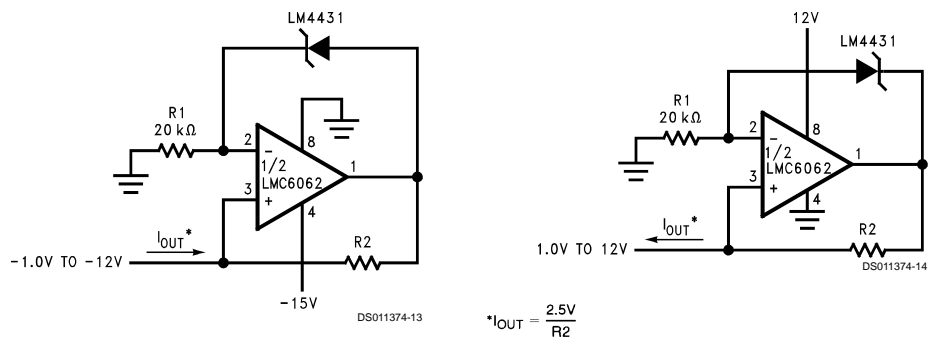
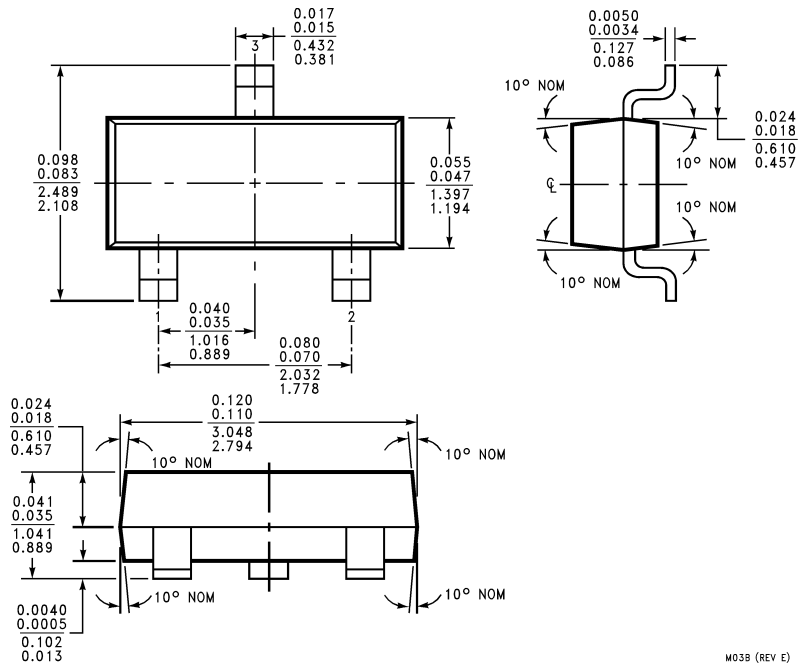

FIGURE 5. Precision 1 μA to 1 mA Current Sources

$$*I_{OUT} = \frac{2.5V}{R2}$$



**Physical Dimensions** inches (millimeters) unless otherwise noted



**Plastic Surface Mount Package (M3)  
NS Package Number M03B  
(JEDEC Registration TO-236AB)**

M03B (REV E)

**LIFE SUPPORT POLICY**

NATIONAL'S PRODUCTS ARE NOT AUTHORIZED FOR USE AS CRITICAL COMPONENTS IN LIFE SUPPORT DEVICES OR SYSTEMS WITHOUT THE EXPRESS WRITTEN APPROVAL OF THE PRESIDENT OF NATIONAL SEMICONDUCTOR CORPORATION. As used herein:

1. Life support devices or systems are devices or systems which, (a) are intended for surgical implant into the body, or (b) support or sustain life, and whose failure to perform when properly used in accordance with instructions for use provided in the labeling, can be reasonably expected to result in a significant injury to the user.
2. A critical component in any component of a life support device or system whose failure to perform can be reasonably expected to cause the failure of the life support device or system, or to affect its safety or effectiveness.



**National Semiconductor Corporation**  
Americas  
Tel: 1-800-272-9959  
Fax: 1-800-737-7018  
Email: support@nsc.com

**National Semiconductor Europe**  
Fax: +49 (0) 1 80-530 85 86  
Email: europe.support@nsc.com  
Deutsch Tel: +49 (0) 1 80-530 85 85  
English Tel: +49 (0) 1 80-532 78 32  
Français Tel: +49 (0) 1 80-532 93 58  
Italiano Tel: +49 (0) 1 80-534 16 80

**National Semiconductor Asia Pacific Customer Response Group**  
Tel: 65-2544466  
Fax: 65-2504466  
Email: sea.support@nsc.com

**National Semiconductor Japan Ltd.**  
Tel: 81-3-5620-6175  
Fax: 81-3-5620-6179

www.national.com

National does not assume any responsibility for use of any circuitry described, no circuit patent licenses are implied and National reserves the right at any time without notice to change said circuitry and specifications.