

Features

- Precision reference voltage
 - AP431: 2.495V ± 1%
 - AP431A: 2.495V ± 0.5%
- Sink current capability: 200mA
- Minimum cathode current for regulation: 300µA
- Equivalent full-range temp coefficient: 30 ppm/oC
- Fast turn-on response
- Low dynamic output impedance: 0.2Ω
- Programmable output voltage to 36V
- Low output noise
- Lead Free packages: SOT25, SC59, SC59R, SOT89-3L and TO92-3L
- SOT23, SOT23R, SOT25, SC59, SC59R, SOP-8L, SOT89-3L, TO92-3L: Available in “Green” Molding Compound (No Br, Sb)
- Lead Free Finish/ RoHS Compliant (Note 1)

Description

The AP431 and AP431A are 3-terminal adjustable precision shunt regulators with guaranteed temperature stability over the applicable extended commercial temperature range. The output voltage may be set at any level greater than 2.495V (V_{REF}) up to 36V merely by selecting two external resistors that act as a voltage divider network. These devices have a typical output impedance of 0.2Ω. Active output circuitry provides very sharp turn-on characteristics, making these devices excellent improved replacements for Zener diodes in many applications.

The precise (+/-) 1% Reference voltage tolerance of the AP431/AP431A make it possible in many applications to avoid the use of a variable resistor, consequently saving cost and eliminating drift and reliability problems associated with it.

Notes: 1. EU Directive 2002/95/EC (RoHS). All applicable RoHS exemptions applied. Please visit our website at http://www.diodes.com/products/lead_free.html.

Typical Application Circuit

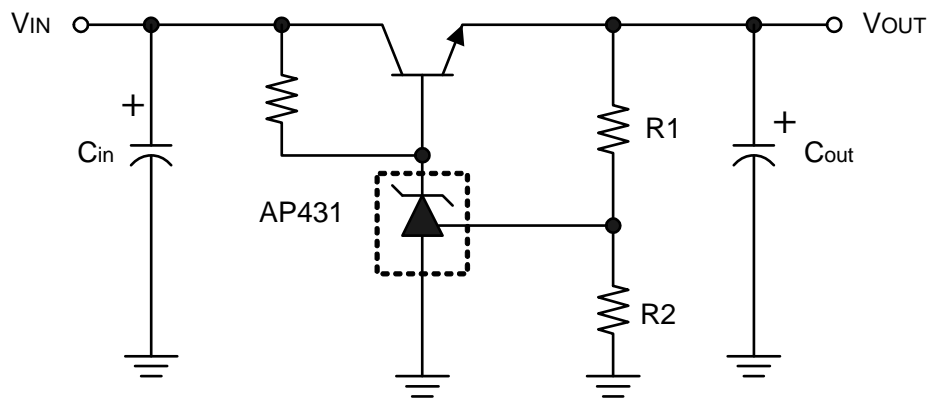

$$V_{OUT} = (1 + R1/R2)V_{REF}$$

Precision Regulator

Pin Assignments

(1) SOT25

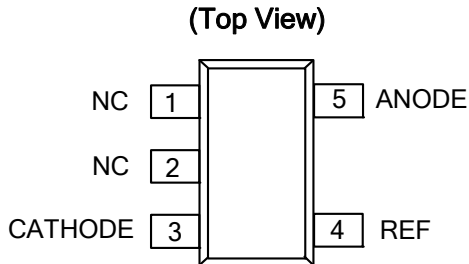

(2) SOP-8L

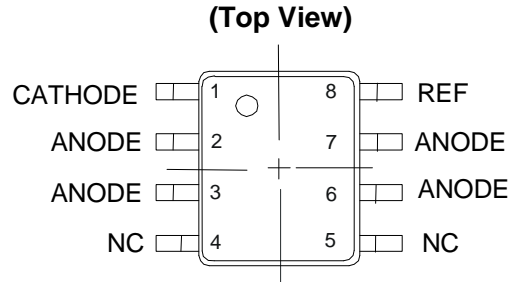

(3) SC59

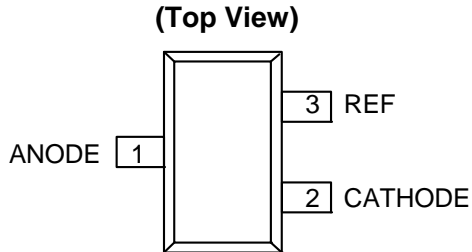

(4) SC59R

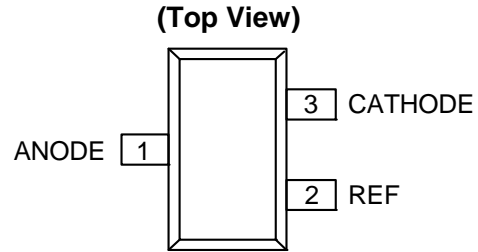

(5) SOT23

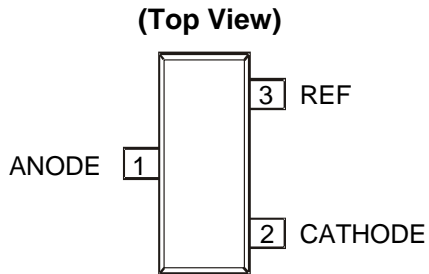

(6) SOT23R

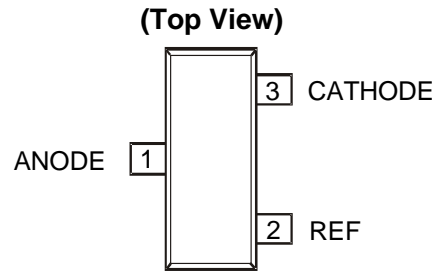

(7) SOT89-3L

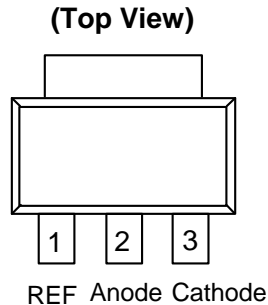

(8) TO92-3L

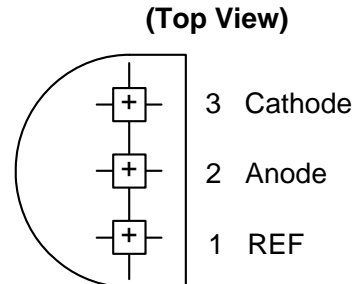

Functional Block Diagram

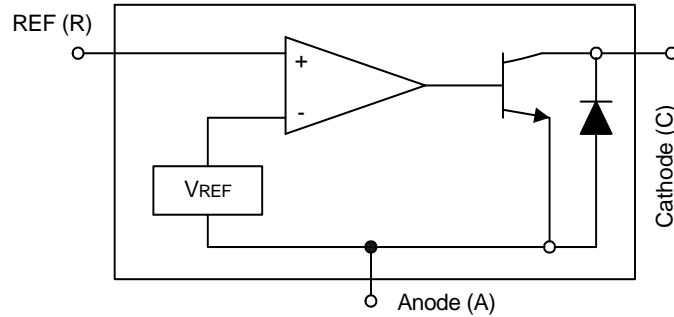

Symbol

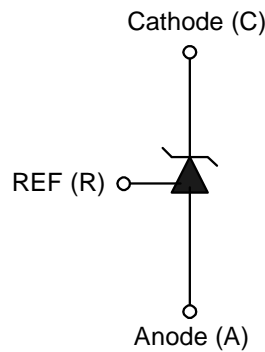

Absolute Maximum Ratings

Symbol	Parameter	Rating	Unit	
V _{CV}	Cathode Voltage	+36	V	
I _{CC}	Continuous Cathode Current	-10 to +250	mA	
I _{REF}	Reference Input Current	10	mA	
T _{OP}	Operating Temperature	-20 to +85	°C	
T _{ST}	Storage Temperature	-65 to +150	°C	
P _D	Power Dissipation (Notes 2, 3)	SOT23(R)	400	mW
		SOT25	550	mW
		SC59(R)	400	mW
		SOP-8L	600	mW
		SOT89-3L	800	mW
		TO92-3L	780	mW

Notes: 2. T_J, max =150°C.
3. Ratings apply to ambient temperature at 25°C.

Electrical Characteristics ($T_A = 25^\circ\text{C}$, $V^+ = +5.0\text{V}$, unless otherwise stated)

Symbol	Parameter	Test Conditions	Min	Typ.	Max	Unit	
V_{REF}	Reference voltage	$V_{KA} = V_{REF}$, $I_{KA} = 10\text{mA}$ (Fig.1)	AP431 2.470 AP431A 2.482	2.495	2.520 2.507	V	
V_{REF}	Deviation of Reference input voltage over temperature (Note 4)	$V_{KA} = V_{REF}$, $I_{KA} = 10\text{mA}$, $T_a = \text{Full range}$ (Fig.1)	—	8.0	20	mV	
$\frac{\Delta V_{REF}}{\Delta V_{KA}}$	Ratio of the change in Reference voltage to the change in Cathode voltage	$I_{KA} = 10\text{mA}$ (Fig. 2)	$V_{KA} = V_{REF}$ to 10V	—	-1.4	-2.0	mV/V
			$V_{KA} = 10\text{V}$ to 36V	—	-1	-2	mV/V
I_{REF}	Reference input current	$R1 = 10\text{K}\Omega$, $R2 = \infty$, $I_{KA} = 10\text{mA}$ (Fig. 2)	—	1.4	3.5	μA	
αI_{REF}	Deviation of Reference input current over temperature	$R1 = 10\text{K}\Omega$, $R2 = \infty$, $I_{KA} = 10\text{mA}$, $T_a = \text{Full range}$ (Fig. 2)	—	0.4	1.2	μA	
$I_{KA(MIN)}$	Minimum Cathode current for regulation	$V_{KA} = V_{REF}$ (Fig.1)	—	0.19	0.5	mA	
$I_{KA(OFF)}$	Off-state current	$V_{KA} = 36\text{V}$, $V_{REF} = 0\text{V}$ (Fig. 3)	—	0.1	1.0	μA	
$ Z_{KA} $	Dynamic output impedance (Note 5)	$V_{KA} = V_{REF}$, $V_{KA} = V_{REF}$, $\Delta I_{KA} = 0.1\text{mA} \sim 15\text{mA}$, Frequency $\leq 1\text{KHz}$ (Fig.1)	—	0.2	0.5	Ω	

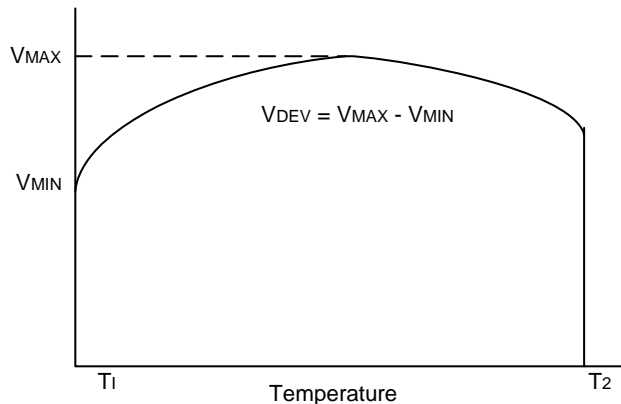

Notes: 4. Deviation of reference input voltage, V_{DEV} , is defined as the maximum variation of the reference over the full temperature range. The average temperature coefficient of the reference input voltage αV_{REF} is defined as:

$$|\alpha V_{REF}| = \frac{\left(\frac{V_{DEV}}{V_{REF}(25^\circ\text{C})}\right) \cdot 10^6}{T_2 - T_1} \dots\dots\dots (\text{ppm}/^\circ\text{C})$$

Where:
 $T_2 - T_1$ = full temperature change.
 αV_{REF} can be positive or negative depending on whether the slope is positive or negative.

Notes: 5. The dynamic output impedance, R_z , is defined as:

$$|Z_{KA}| = \frac{\Delta V_{KA}}{\Delta I_{KA}}$$

When the device is programmed with two external resistors $R1$ and $R2$ (see Figure 2.), the dynamic output impedance of the overall circuit, is defined as:

$$|Z_{KA}'| = \frac{\Delta V}{\Delta i} \approx |Z_{KA}| \left(1 + \frac{R1}{R2}\right)$$

Test Circuits

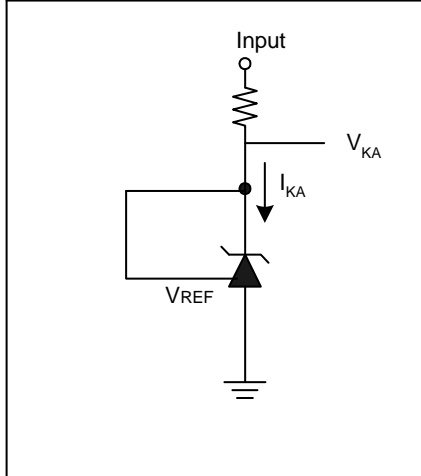
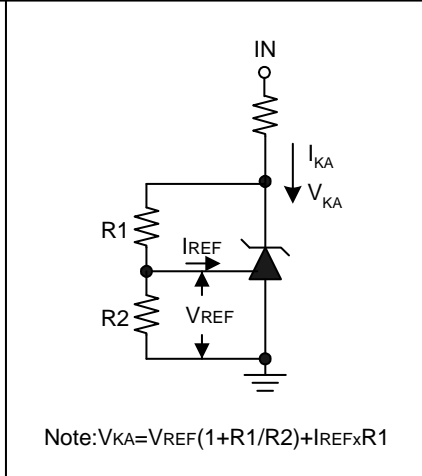

Fig 1. Test Circuit for $V_{KA} = V_{REF}$



Note: $V_{KA} = V_{REF}(1 + R1/R2) + I_{REF} \times R1$

Fig 2. Test Circuit for $V_{KA} > V_{REF}$

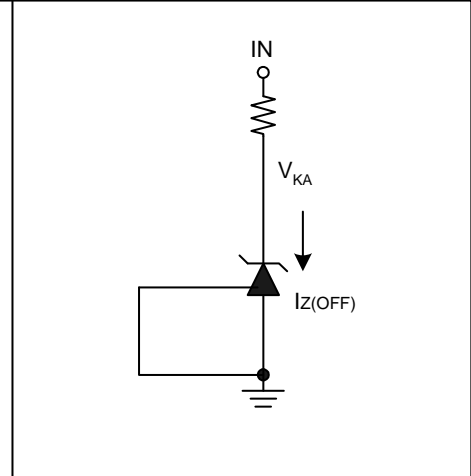
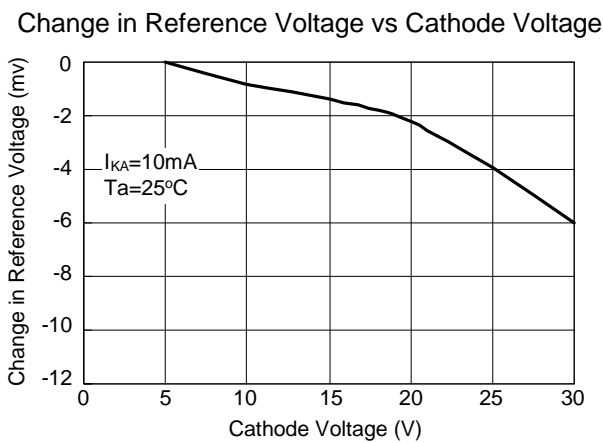
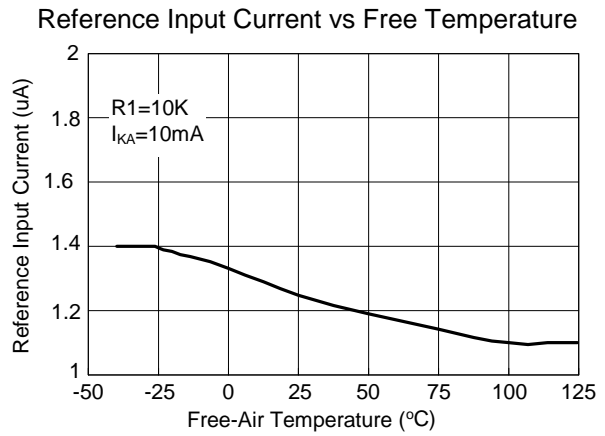
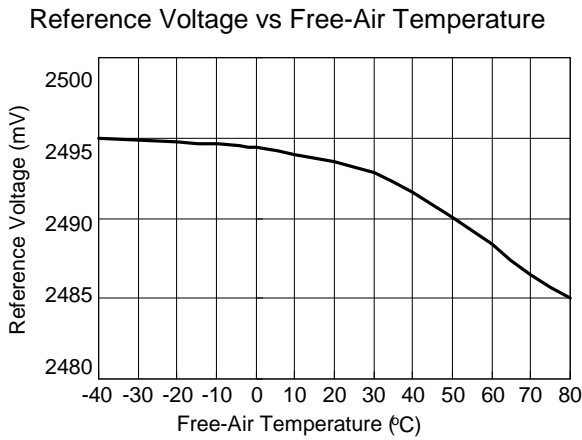
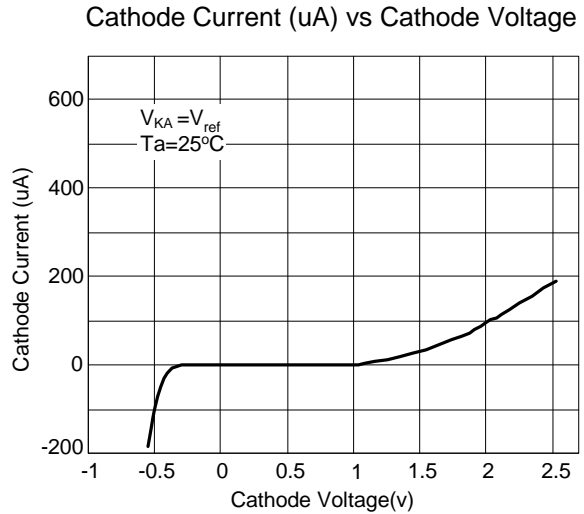
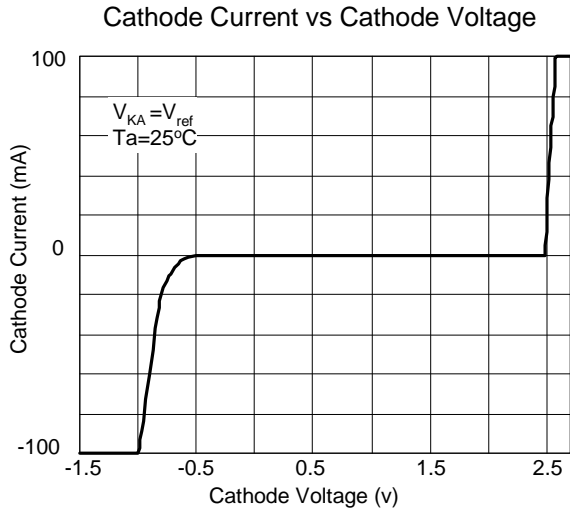

Fig 3. Test Circuit for Off-State Current

Typical Performance Characteristics



Typical Performance Characteristics (Continued)

Small-Signal Voltage Amplification vs Frequency

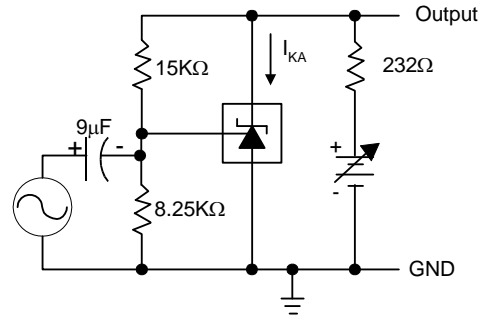
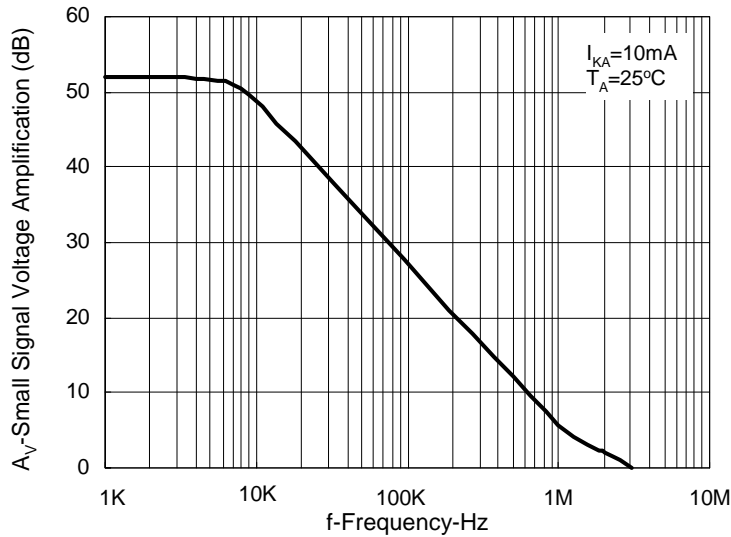

Test Circuit for Voltage Amplification

Reference Impedance vs Frequency

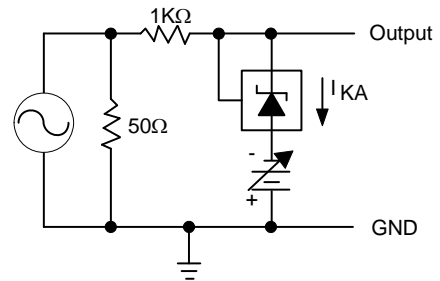
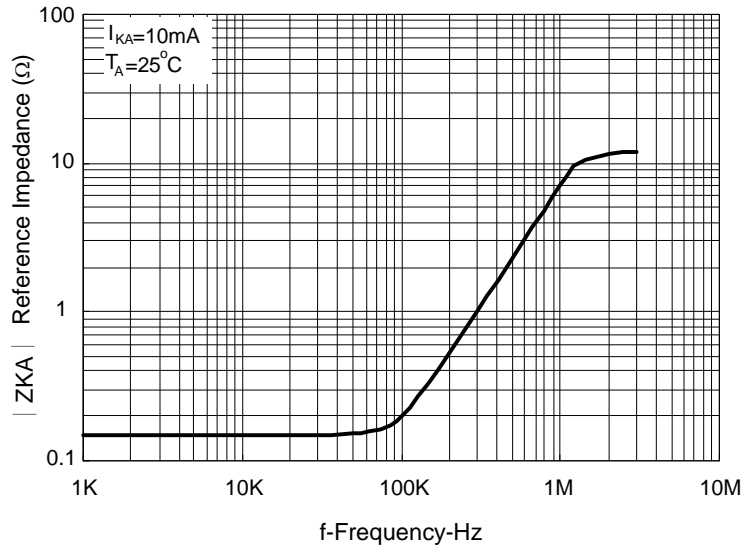

Test Circuit for Reference Impedance

Typical Performance Characteristics (Continued)

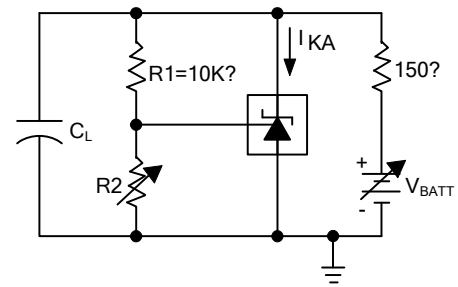
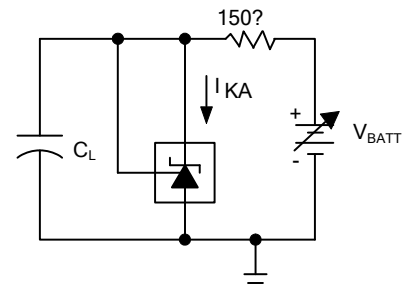
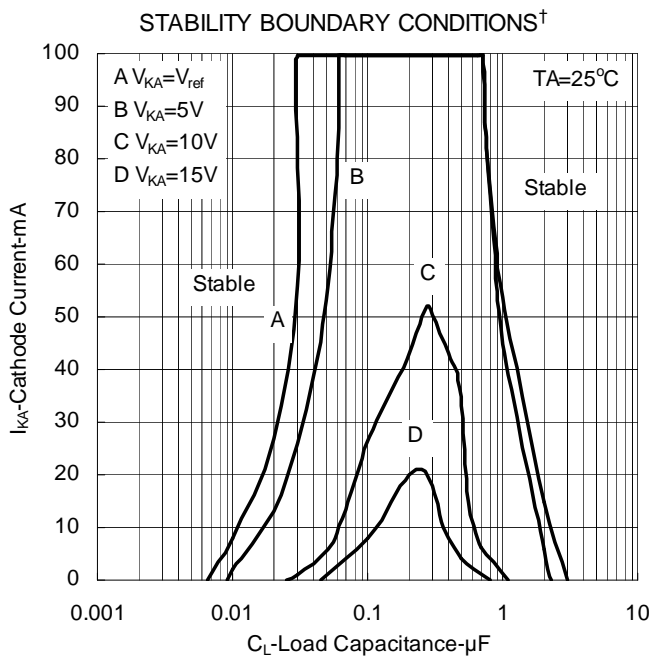
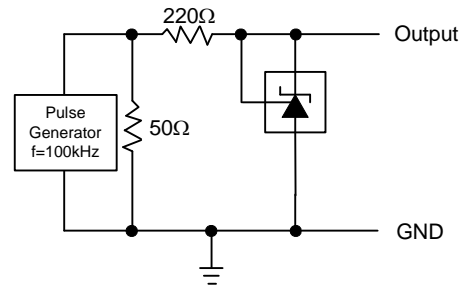
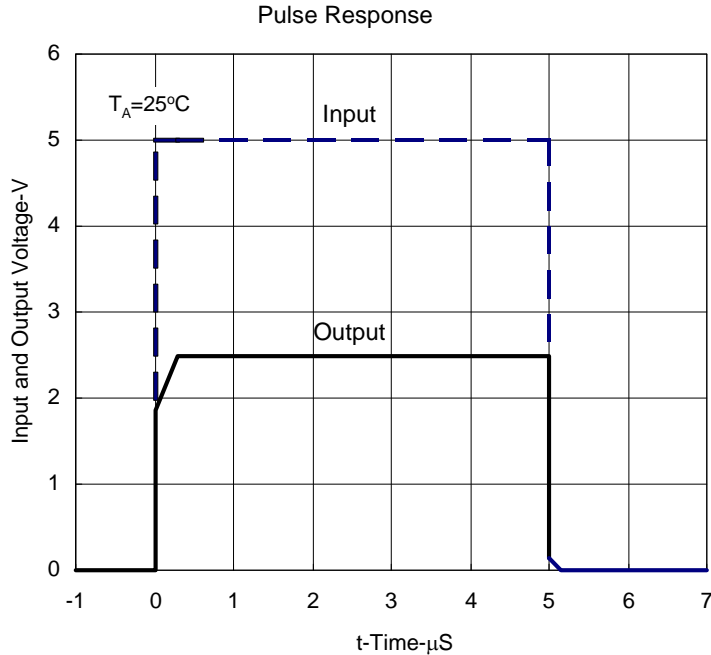





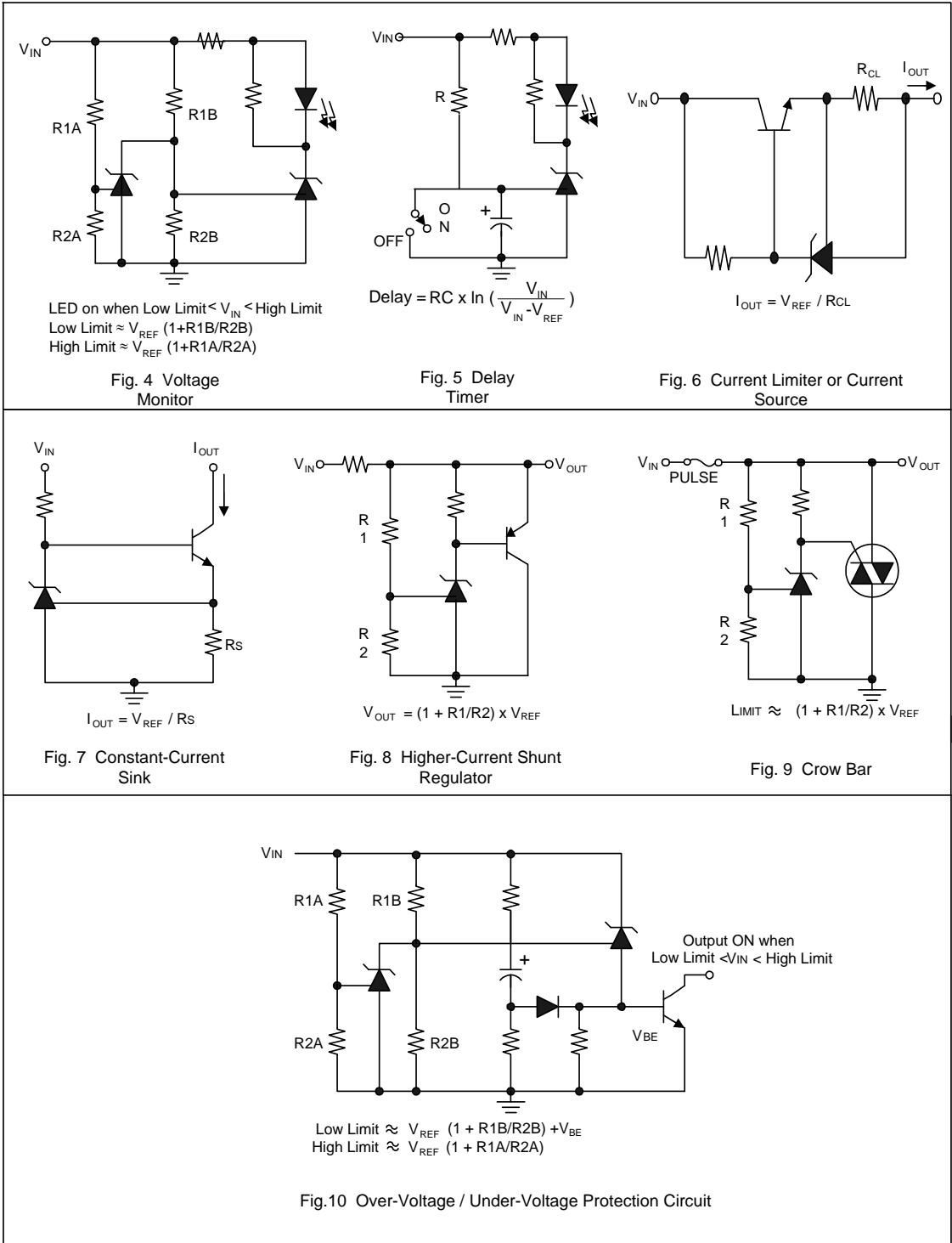



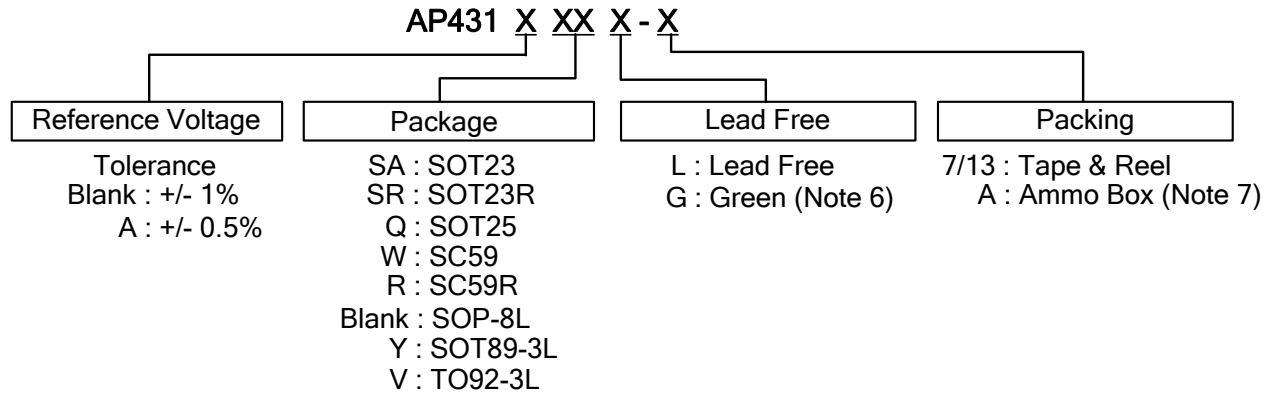





[†] The areas under the curves represent conditions that may cause the device to oscillate. For curves B, C, and D, R2 and V+ were adjusted to establish the initial V_{KA} and I_{KA} conditions with $C_L=0$. V_{BATT} and C_L were then adjusted to determine the ranges of stability.

Application Examples



Ordering Information



	Device (Note 8)	Package Code	Packaging (Note 9)	7"/13 Tape and Reel		Ammo Box	
				Quantity	Part Number Suffix	Quantity	Part Number Suffix
	AP431(A)SAG-7	SA	SOT23	3000/Tape & Reel	-7	NA	NA
	AP431(A)SRG-7	SR	SOT23R	3000/Tape & Reel	-7	NA	NA
	AP431(A)QL-7	Q	SOT25	3000/Tape & Reel	-7	NA	NA
	AP431(A)QG-7	Q	SOT25	3000/Tape & Reel	-7	NA	NA
	AP431(A)WL-7	W	SC59	3000/Tape & Reel	-7	NA	NA
	AP431(A)WG-7	W	SC59	3000/Tape & Reel	-7	NA	NA
	AP431(A)RL-7	R	SC59R	3000/Tape & Reel	-7	NA	NA
	AP431(A)RG-7	R	SC59R	3000/Tape & Reel	-7	NA	NA
	AP431(A)G-13		SOP-8L	2500/Tape & Reel	-13	NA	NA
	AP431(A)YL-13	Y	SOT89-3L	2500/Tape & Reel	-13	NA	NA
	AP431(A)YG-13	Y	SOT89-3L	2500/Tape & Reel	-13	NA	NA
	AP431(A)VL-A	V	TO92-3L	NA	NA	2000/Box	NA
	AP431(A)VG-A	V	TO92-3L	NA	NA	2000/Box	NA

- Notes:
6. SOP-8L, SOT23 and SOT23R are available in "Green" products only.
 7. Ammo Box is for TO92-3L Spread Lead.
 8. Suffix "A" denotes AP431A device.
 9. Pad layout as shown on Diodes Inc. suggested pad layout document AP02001, which can be found on our website at <http://www.diodes.com/datasheets/ap02001.pdf>.

Marking Information

(1) SC59 and SC59R

(Top View)

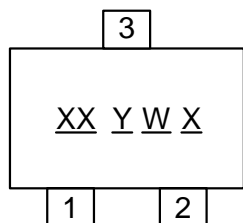

XX : Identification code
Y : Year 0~9
W : Week : A~Z : 1~26 week;
a~z : 27~52 week; z represents
52 and 53 week
X : A~Z : Green
a~z : Lead Free

(2) SOT23 and SOT23R

(Top View)

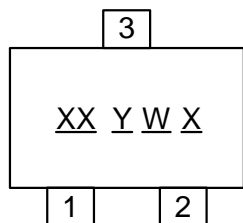

XX : Identification code
Y : Year 0~9
W : Week : A~Z : 1~26 week;
a~z : 27~52 week; z represents
52 and 53 week
X : A~Z : Green

(3) SOT25

(Top View)

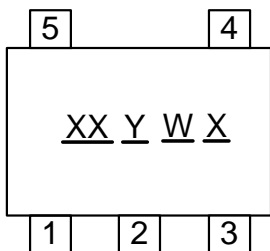

XX : Identification code
Y : Year 0~9
W : Week : A~Z : 1~26 week;
a~z : 27~52 week; z represents
52 and 53 week
X : A~Z : Green
a~z : Lead Free

(4) SOP-8L

(Top View)

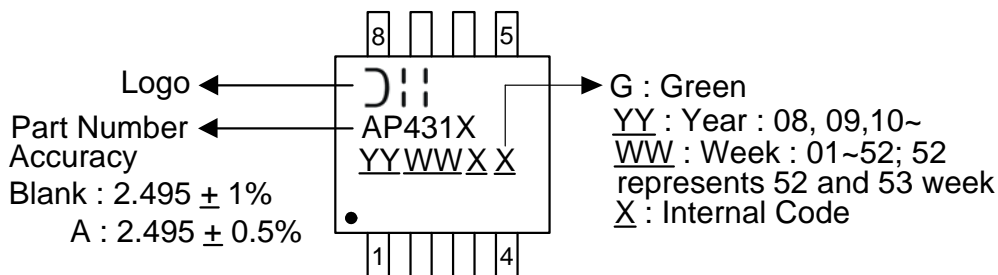

Logo
Part Number Accuracy
Blank : $2.495 \pm 1\%$
A : $2.495 \pm 0.5\%$

G : Green
YY : Year : 08, 09, 10~
WW : Week : 01~52; 52
represents 52 and 53 week
X : Internal Code

Marking Information (Continued)

(5) SOT89-3L

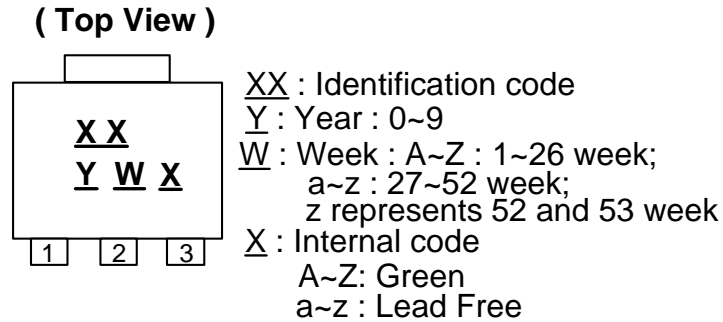

(6) TO92-3L

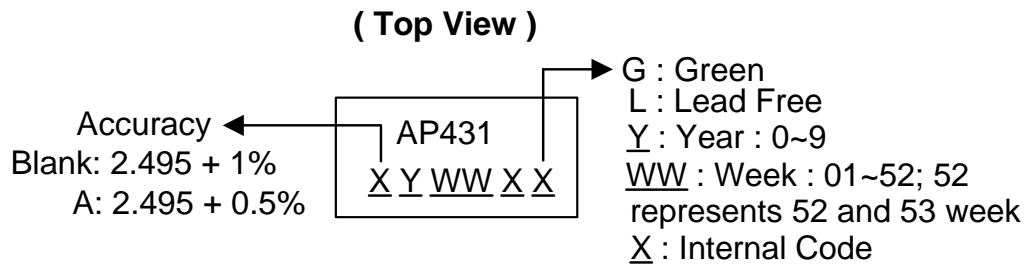

Identification Code Table

Device	Package (Note 10)	Identification Code	Date Code
AP431SA	SOT23	D1	YM
AP431ASA	SOT23	D2	YM
AP431SR	SOT23R	D5	YM
AP431ASR	SOT23R	D6	YM
AP431Q	SOT25	A2	YM
AP431AQ	SOT25	A3	YM
AP431W	SC59	A6	YM
AP431AW	SC59	A7	YM
AP431R	SC59	A8	YM
AP431AR	SC59	A9	YM
AP431Y	SOT89-3L	A4	YM
AP431AY	SOT89-3L	A5	YM

Notes: 10. For Packaging Details, go to our website at <http://www.diodes.com/datasheets/ap02007.pdf>.

Package Outline Dimensions (All Dimensions in mm)

(1) Package type: SOT25

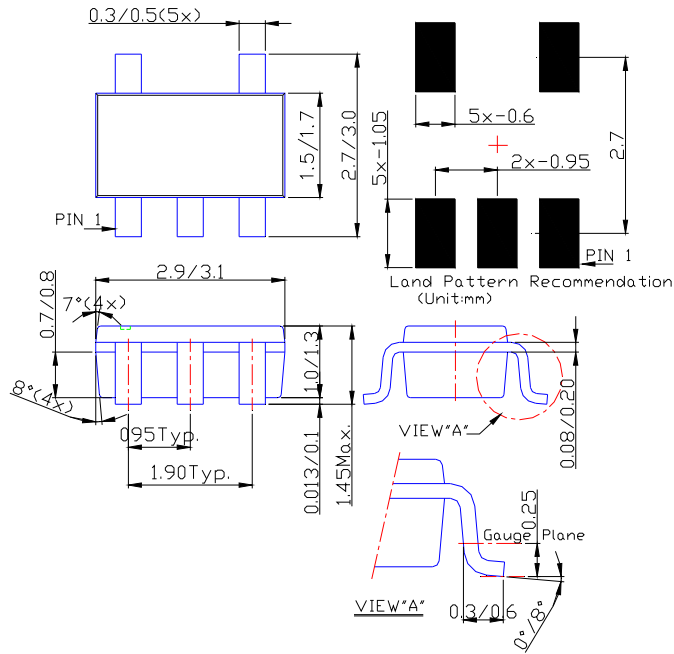

(2) Package Type: SC59 and SC59R

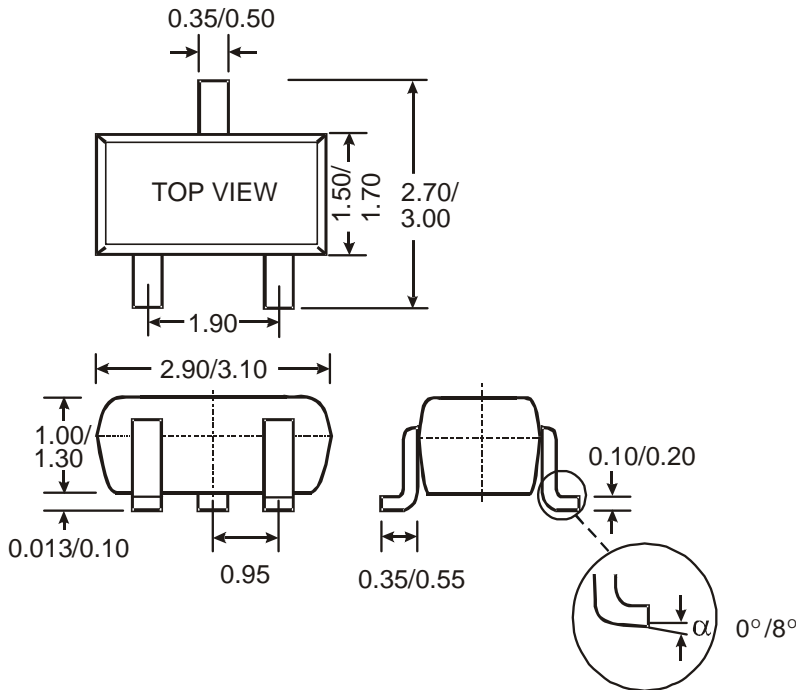

Package Outline Dimensions (Continued)

(3) Package Types: SOT23 and SOT23R

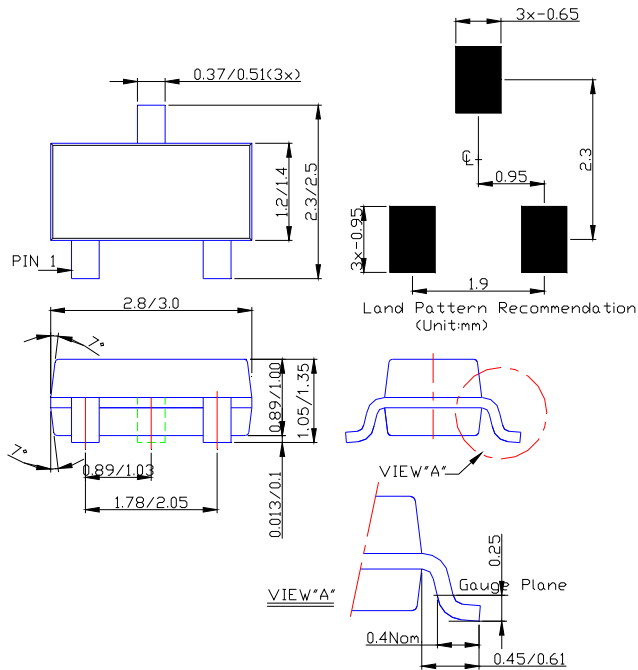

(4) Package Type: SOP-8L

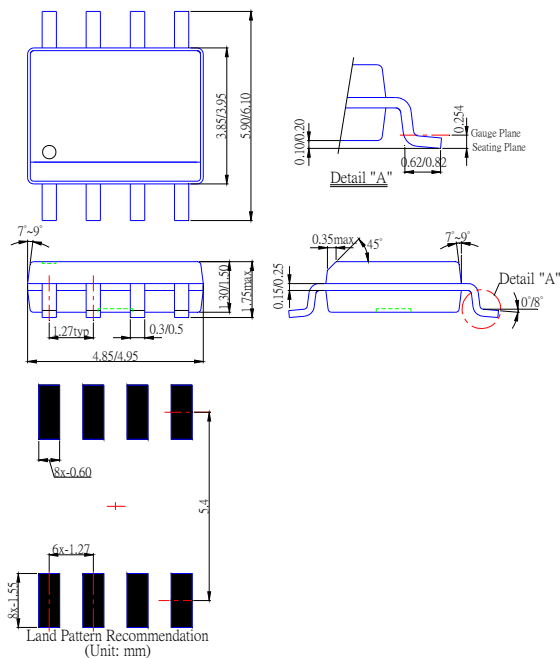

Package Outline Dimensions (Continued)

(5) Package Type: SOT89-3L

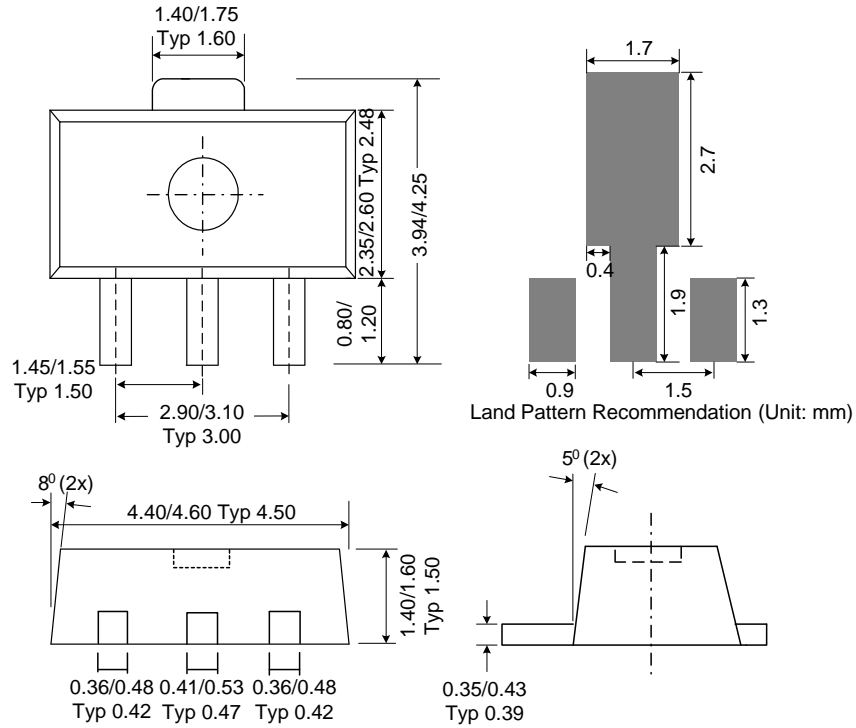

(6) Package Type: TO92-3L for Ammo pack

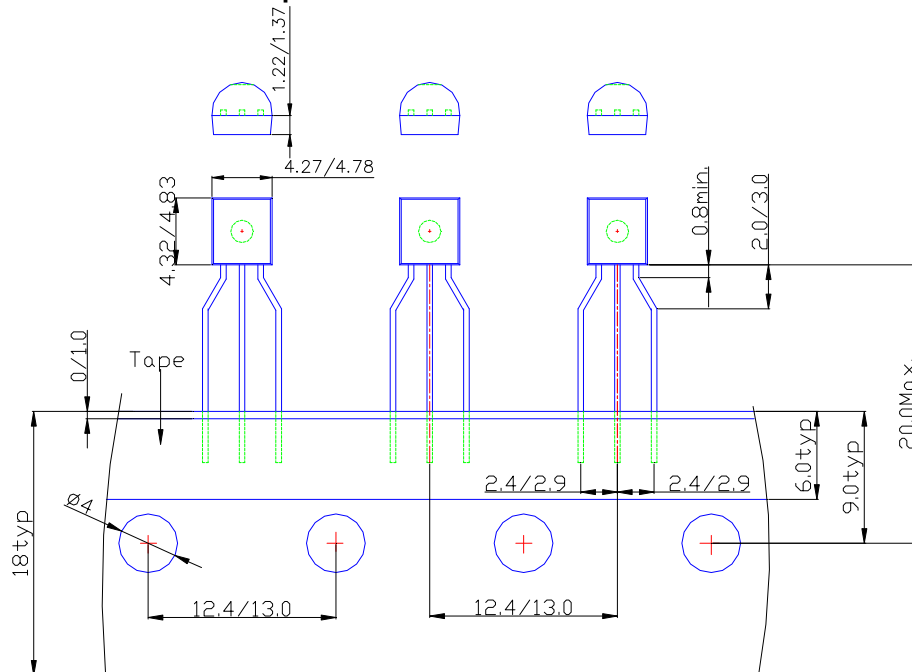

IMPORTANT NOTICE

DIODES INCORPORATED MAKES NO WARRANTY OF ANY KIND, EXPRESS OR IMPLIED, WITH REGARDS TO THIS DOCUMENT, INCLUDING, BUT NOT LIMITED TO, THE IMPLIED WARRANTIES OF MERCHANTABILITY AND FITNESS FOR A PARTICULAR PURPOSE (AND THEIR EQUIVALENTS UNDER THE LAWS OF ANY JURISDICTION).

Diodes Incorporated and its subsidiaries reserve the right to make modifications, enhancements, improvements, corrections or other changes without further notice to this document and any product described herein. Diodes Incorporated does not assume any liability arising out of the application or use of this document or any product described herein; neither does Diodes Incorporated convey any license under its patent or trademark rights, nor the rights of others. Any Customer or user of this document or products described herein in such applications shall assume all risks of such use and will agree to hold Diodes Incorporated and all the companies whose products are represented on Diodes Incorporated website, harmless against all damages.

Diodes Incorporated does not warrant or accept any liability whatsoever in respect of any products purchased through unauthorized sales channel.

Should Customers purchase or use Diodes Incorporated products for any unintended or unauthorized application, Customers shall indemnify and hold Diodes Incorporated and its representatives harmless against all claims, damages, expenses, and attorney fees arising out of, directly or indirectly, any claim of personal injury or death associated with such unintended or unauthorized application.

Products described herein may be covered by one or more United States, international or foreign patents pending. Product names and markings noted herein may also be covered by one or more United States, international or foreign trademarks.

LIFE SUPPORT

Diodes Incorporated products are specifically not authorized for use as critical components in life support devices or systems without the express written approval of the Chief Executive Officer of Diodes Incorporated. As used herein:

A. Life support devices or systems are devices or systems which:

1. are intended to implant into the body, or
2. support or sustain life and whose failure to perform when properly used in accordance with instructions for use provided in the labeling can be reasonably expected to result in significant injury to the user.

B. A critical component is any component in a life support device or system whose failure to perform can be reasonably expected to cause the failure of the life support device or to affect its safety or effectiveness.

Customers represent that they have all necessary expertise in the safety and regulatory ramifications of their life support devices or systems, and acknowledge and agree that they are solely responsible for all legal, regulatory and safety-related requirements concerning their products and any use of Diodes Incorporated products in such safety-critical, life support devices or systems, notwithstanding any devices- or systems-related information or support that may be provided by Diodes Incorporated. Further, Customers must fully indemnify Diodes Incorporated and its representatives against any damages arising out of the use of Diodes Incorporated products in such safety-critical, life support devices or systems.

Copyright © 2010, Diodes Incorporated

www.diodes.com