



# SOT Temperature Sensor with Multidrop Single-Wire Digital Interface

MAX6575L/H

## General Description

The MAX6575L/H is a low-cost, low-current temperature sensor with a single-wire digital interface. It features accuracy of  $\pm 3^{\circ}\text{C}$  at  $+25^{\circ}\text{C}$ ,  $\pm 4.5^{\circ}\text{C}$  at  $+85^{\circ}\text{C}$ , and  $\pm 5^{\circ}\text{C}$  at  $+125^{\circ}\text{C}$ . The MAX6575L/H is a monostable, externally triggered temperature sensor that allows a microprocessor ( $\mu\text{P}$ ) to interface with up to eight temperature sensors using a single control line. Temperatures are sensed by measuring the time delay between the falling edge of the external triggering pulse and the falling edge of the subsequent pulse delays reported from the devices. Different sensors on the same I/O line use different timeout multipliers to avoid overlapping signals.

The MAX6575L/H features eight different timeout multipliers; these are selectable by using the two time-select pins on each device and choosing the "L" or "H" version. The "L" version provides four delay ranges less than 50ms. The "H" version provides four delay ranges greater than 50ms. The MAX6575L/H is available in a space-saving 6-pin SOT23 package.

## Applications

Critical  $\mu\text{P}$  and  $\mu\text{C}$  Temperature Monitoring  
 Portable Battery-Powered Equipment  
 Cell Phones  
 Battery Packs  
 Hard Drives/Tape Drives  
 Networking and Telecom Equipment  
 Medical Equipment  
 Automotive

## Features

- ◆ Simple Single-Wire Interface to  $\mu\text{P}$  or  $\mu\text{C}$
- ◆ Multidrop up to Eight Sensors on One Wire
- ◆  $\pm 0.8^{\circ}\text{C}$  Accuracy at  $+25^{\circ}\text{C}$  ( $\pm 3^{\circ}\text{C}$  max)
- ◆ Operates from  $+2.7\text{V}$  to  $+5.5\text{V}$  Supply Voltage
- ◆ Low  $150\mu\text{A}$  (typ) Supply Current
- ◆ Standard Operating Temperature Range:  $-40^{\circ}\text{C}$  to  $+125^{\circ}\text{C}$
- ◆ Small 6-Pin SOT23 Package

## Ordering Information

PART	TEMP. RANGE	PIN-PACKAGE	SOT TOP MARK
MAX6575LZUT	$-40^{\circ}\text{C}$ to $+125^{\circ}\text{C}$	6 SOT23	AABG
MAX6575HZUT	$-40^{\circ}\text{C}$ to $+125^{\circ}\text{C}$	6 SOT23	AABH

## Selector Guide

PART	TIMEOUT MULTIPLIERS ( $\mu\text{s}/^{\circ}\text{K}$ )
MAX6575L	5, 20, 40, 80
MAX6575H	160, 320, 480, 640

Pin Configurations appear at end of data sheet.

## Typical Operating Circuit

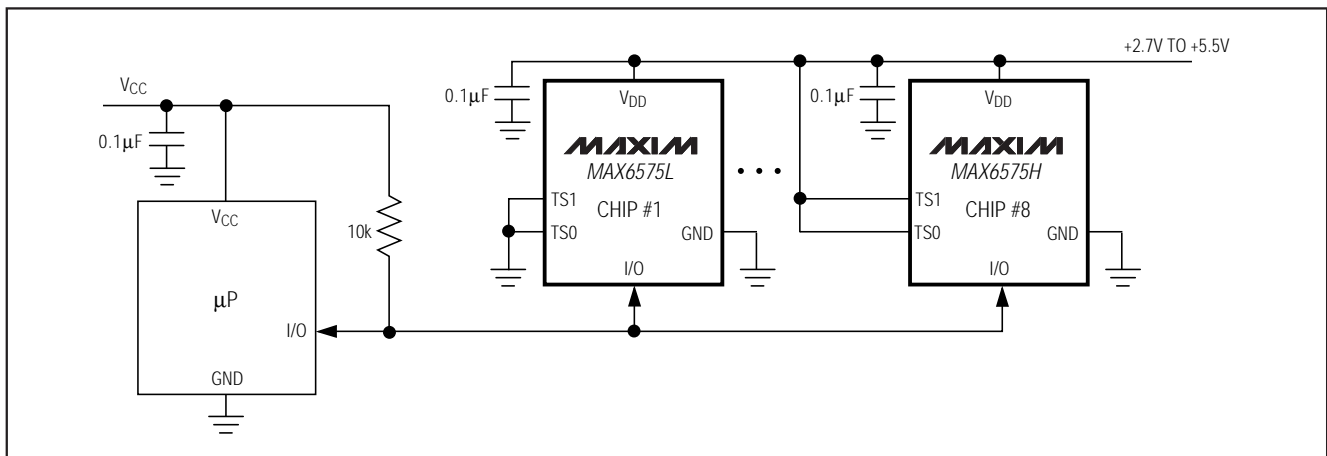

Maxim Integrated Products 1

For free samples & the latest literature: <http://www.maxim-ic.com>, or phone 1-800-998-8800.  
 For small orders, phone 1-800-835-8769.

# SOT Temperature Sensor with Multidrop Single-Wire Digital Interface

## ABSOLUTE MAXIMUM RATINGS

Terminal Voltage (with respect to GND)

V <sub>DD</sub> .....	-0.3V to +6V
TS1, TS0 .....	-0.3V to (V <sub>DD</sub> + 0.3V)
I/O .....	-0.3V to +6V
Input/Output Current, All Pins .....	±20mA

Continuous Power Dissipation (T<sub>A</sub> = +70°C)

6-Pin SOT23 (derate 7.10mW/°C above +70°C) .....	571mW
Operating Temperature Range .....	-40°C to +125°C
Storage Temperature Range .....	-65°C to +150°C
Lead Temperature (soldering, 10sec) .....	+300°C

Stresses beyond those listed under "Absolute Maximum Ratings" may cause permanent damage to the device. These are stress ratings only, and functional operation of the device at these or any other conditions beyond those indicated in the operational sections of the specifications is not implied. Exposure to absolute maximum rating conditions for extended periods may affect device reliability.

## ELECTRICAL CHARACTERISTICS

(V<sub>DD</sub> = +2.7V to +5.5V, T<sub>A</sub> = -40°C to +125°C, unless otherwise noted. Typical values are specified at T<sub>A</sub> = +25°C and V<sub>DD</sub> = +5V, unless otherwise noted.)

PARAMETER	SYMBOL	CONDITIONS		MIN	TYP	MAX	UNITS
V <sub>DD</sub> Range	V <sub>DD</sub>			2.7		5.5	V
Supply Current	I <sub>DD</sub>	V <sub>DD</sub> = 5.5V	T <sub>A</sub> = -40°C to +85°C		150	250	μA
			T <sub>A</sub> = -40°C to +125°C			400	
Temperature Sensor Error (Note 1)			T <sub>A</sub> = -20°C	-7.5	±1.1	+7.5	°C
			T <sub>A</sub> = 0°C	-5.5	±0.9	+5.5	
			T <sub>A</sub> = +25°C	-3.0	±0.8	+3.0	
			T <sub>A</sub> = +85°C	-4.5	±0.5	+4.5	
			T <sub>A</sub> = +125°C	-5.0	±0.5	+5.0	
Output Pulse Delay	t <sub>D1</sub>	MAX6575L, T (temp) in °K, Figure 1	V <sub>TS1</sub> = GND, V <sub>TS0</sub> = GND		5T		μs
	t <sub>D2</sub>		V <sub>TS1</sub> = GND, V <sub>TS0</sub> = V <sub>DD</sub>		20T		
	t <sub>D3</sub>		V <sub>TS1</sub> = V <sub>DD</sub> , V <sub>TS0</sub> = GND		40T		
	t <sub>D4</sub>		V <sub>TS1</sub> = V <sub>DD</sub> , V <sub>TS0</sub> = V <sub>DD</sub>		80T		
	t <sub>D5</sub>	MAX6575H, T (temp) in °K, Figure 1	V <sub>TS1</sub> = GND, V <sub>TS0</sub> = GND		160T		
	t <sub>D6</sub>		V <sub>TS1</sub> = GND, V <sub>TS0</sub> = V <sub>DD</sub>		320T		
	t <sub>D7</sub>		V <sub>TS1</sub> = V <sub>DD</sub> , V <sub>TS0</sub> = GND		480T		
	t <sub>D8</sub>		V <sub>TS1</sub> = V <sub>DD</sub> , V <sub>TS0</sub> = V <sub>DD</sub>		640T		
Output Pulse Low Time	t <sub>L1-8</sub>	Figure 1			5T		μs
Reset Pulse Width (Note 2)	t <sub>RESET</sub>	Figure 1		4.6		16.0	ms
Setup Time	t <sub>SETUP</sub>	Figure 1			10		μs
Start Pulse (Note 3)	t <sub>START</sub>	Figure 1, T <sub>A</sub> = +25°C		2.5			μs
Delay Time from Trigger to Ready (Note 4)	t <sub>READY</sub>	Figure 1				520	ms
Glitch Immunity on I/O Input					500		ns
Time-Select Pin Logic Levels	V <sub>IL</sub>					0.8	V
	V <sub>IH</sub>			2.3			
I/O Output Voltage Low	V <sub>OL</sub>	V <sub>DD</sub> > 4.5V, I <sub>SINK</sub> = 3.2mA				0.4	V
		V <sub>DD</sub> > 2.7V, I <sub>SINK</sub> = 1.2mA				0.3	
I/O Input Voltage Low	V <sub>IL</sub>					0.8	V
I/O Input Voltage High	V <sub>IH</sub>			2.3			V

**Note 1:** See Temperature Accuracy histograms in *Typical Operating Characteristics*.

**Note 2:** Guaranteed by design. Not production tested.

**Note 3:** Limit maximum start pulse at 1ms to avoid timing overlap.

**Note 4:** If no reset pulse is applied.

# SOT Temperature Sensor with Multidrop Single-Wire Digital Interface

## Typical Operating Characteristics

( $V_{DD} = +5V$ ,  $T_A = +25^\circ C$ , unless otherwise noted.)

MAX6575L/H

**TEMPERATURE ACCURACY**  
( $T_A = +25^\circ C$ )

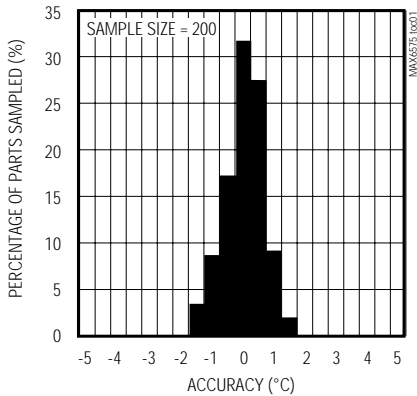

**TEMPERATURE ACCURACY**  
( $T_A = +85^\circ C$ )

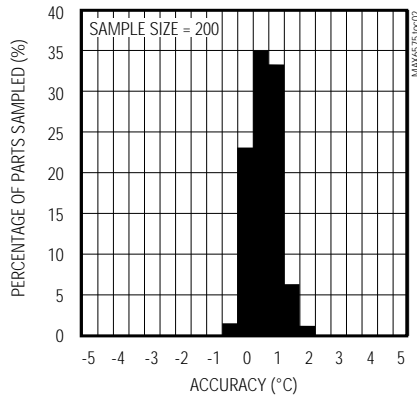

**ACCURACY vs. TEMPERATURE**

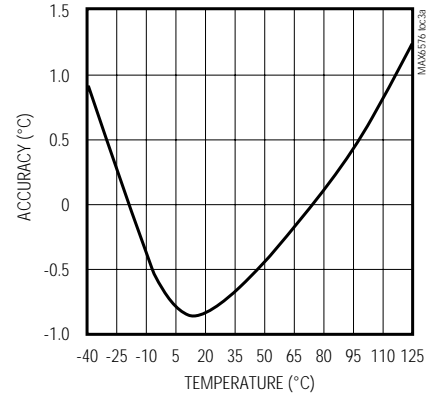

**SUPPLY CURRENT vs. TEMPERATURE**

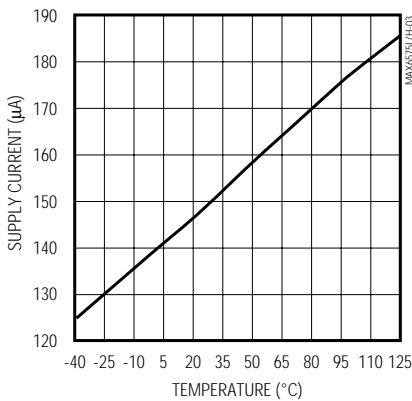

**THERMAL STEP RESPONSE**  
IN PERFLUORINATED FLUID

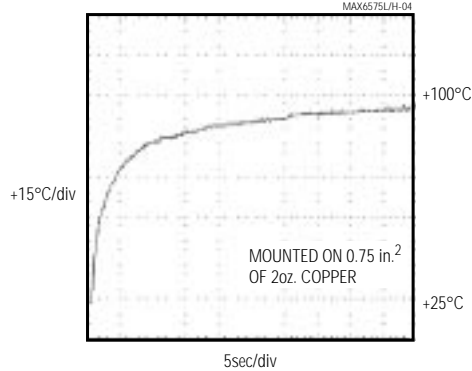

**THERMAL STEP RESPONSE**  
IN STILL AIR

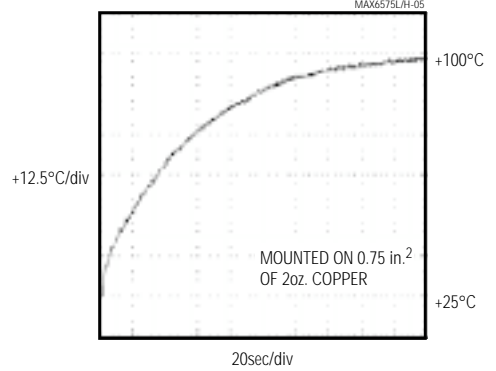

## Pin Description

PIN	NAME	FUNCTION
1	$V_{DD}$	Positive Supply Voltage
2	GND	Ground
3	N.C.	No Connect. Connect pin to GND or leave open.
4, 5	TS0, TS1	Time-Select Pins. Set the time delay factor by connecting TS1 and TS0 to either $V_{DD}$ or GND. See Table 1.
6	I/O	Bidirectional Interface Pin. A time delay between when the part is initiated externally by pulling I/O low and when the part subsequently pulls I/O low, is proportional to absolute temperature ( $^\circ K$ ).

# SOT Temperature Sensor with Multidrop Single-Wire Digital Interface

## Detailed Description

The MAX6575L/H low-cost, low-current (150 $\mu$ A typ) temperature sensor is ideal for interfacing with micro-controllers or microprocessors. The MAX6575L/H is a monostable, externally triggered temperature sensor that uses a Temp $\rightarrow$ Delay conversion to communicate with a  $\mu$ P over a single I/O line. Time-select pins (TS1, TS0) permit the internal temperature-controlled oscillator (TCO) to be scaled by four preset timeout multipliers, allowing eight separate temperature sensors to share one I/O line. Different sensors on the same I/O line will use different timeout multipliers to avoid overlapping signals.

### Operating the MAX6575L/H

Figure 1 illustrates the timing for the MAX6575L/H. When the device is powered up, it assumes a ready state where it awaits an external trigger at the I/O pin. The I/O pin of the MAX6575L/H has an open-drain output structure that requires a pull-up resistor to maintain the proper logic levels. Once the I/O pin is pulled low and then released, control of the I/O pin is transferred to the MAX6575L/H. The temperature conversion begins on the falling edge of the externally triggered pulse. The I/O line is pulled low at a later time. That time is determined by the device temperature and the Time Select pins (TS1, TS0). The I/O line remains low for 5T $\mu$ s, where T is the temperature in degrees Kelvin. The temperature of the device is represented by the edge-to-edge delay of the externally triggered pulse and the falling edge of the subsequent pulse originating from the device. The device can be manually reset by pulling the I/O line low for more than t<sub>RESET</sub> (16ms max). The device will automatically reset after a maxi-

**Table 1. Time-Select Pin Configuration**

TIME-SELECT PINS		TIMEOUT MULTIPLIERS ( $\mu$ s/ $^{\circ}$ K)	
TS1	TS0	MAX6575L	MAX6575H
GND	GND	5	160
GND	V <sub>DD</sub>	20	320
V <sub>DD</sub>	GND	40	480
V <sub>DD</sub>	V <sub>DD</sub>	80	640

mum delay of 520ms, at which point it will again be in a ready state awaiting a start pulse.

Definition of Terms:

t<sub>RESET</sub>: Time I/O must be externally pulled low to guarantee the MAX6575L/H is in a ready state awaiting external trigger. (Part will assume a ready state after 520ms without a reset pulse.)

t<sub>SETUP</sub>: Time I/O must be high prior to a start pulse.

t<sub>START</sub>: Trigger pulse which starts the on-chip timing sequence on its falling edge.

t<sub>Dx</sub>: Timing delay between the falling edge of the start pulse and the falling edge initiated by CHIP#x.

t<sub>Lx</sub>: I/O pulse low time (5T $\mu$ s).

t<sub>READY</sub>: Time after falling edge of start pulse when the MAX6575L/H will reset itself and await the next external trigger.

The temperature, in degrees Celsius, may be calculated as follows:

$$T(^{\circ}\text{C}) = [t_{Dx}(\mu\text{s}) / \text{timeout multiplier}(\mu\text{s}/^{\circ}\text{K})] - 273.15^{\circ}\text{K}$$

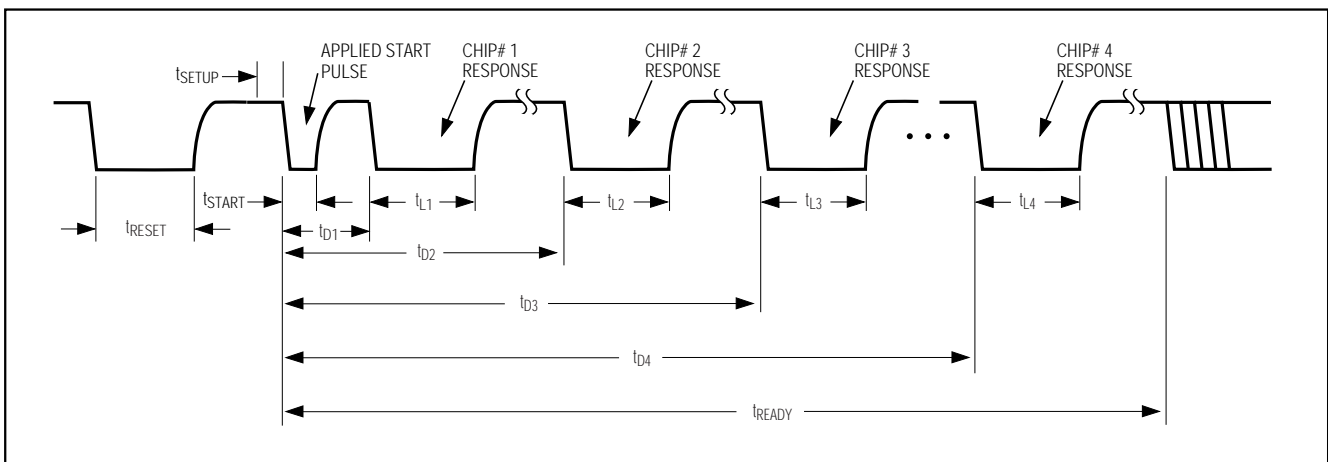

Figure 1. Timing Diagram

# SOT Temperature Sensor with Multidrop Single-Wire Digital Interface

MAX6575L/H

**Table 2. Allowable Temperature Differential (°C)**

TIMEOUT MULTIPLIER	MAX6575L				MAX6575H			
	5	20	40	80	160	320	480	640
5		>165	>165	>165	>165	>165	>165	>165
20			95.5	>165	>165	>165	>165	>165
40				132.0	>165	>165	>165	>165
80					153.5	>165	>165	>165
160						>165	>165	>165
320							70.2	>165
480								37.9
640								

**Table 3. Typical Peak Noise Amplitude**

PARAMETER	MAX6575L				MAX6575H			
Timeout Multiplier	5	20	40	80	160	320	480	640
Noise Amplitude (°C)	±0.33	±0.15	±0.15	±0.098	±0.091	±0.063	±0.043	±0.037

### Time-Select Pins (TS1, TS0)

Table 1 shows the configuration of the Time-select pins for the MAX6575L/H. Each device allows four selectable timeout multipliers intended to prevent overlapping when multiple devices are used on the same I/O line. Tie TS1 and TS0 to either GND or VDD to select the desired temperature multiplier.

To monitor several chips on the same I/O line, different timeout multipliers should be selected using the TS1 and TS0 pins. The timeout periods are then scaled so that the response times will not overlap (see *Timeout Selection*).

## Applications Information

### Timeout Selection

Under extreme temperature conditions, it is possible for an overlap to occur between the timeout delays of different sensors in a multidrop configuration. This overlap can occur only if the temperature differential recorded between two devices is very large. Timeout overlaps can be avoided in multidrop configurations by selecting the appropriate timeout multipliers. Table 2 illustrates the allowable temperature differential between devices when the maximum error is present on each device. Allowable temperature differentials greater than 165°C indicate no overlap.

For example, if the maximum temperature differential in a system is 80°C, the only combinations of timeout multipliers that could result in timeout overlap would be a 320:480µs/°K (70.2°C) or a 480:640µs/°K (37.9°C) combination. As long as these combinations of timeout multipliers are not used in the same multidrop configuration, no overlap can occur. Thus, seven MAX6575L/H parts can be used in the same multidrop configuration if the maximum temperature differential between parts is 80°C. A similar analysis shows that four MAX6575L/H parts can be used when the maximum temperature differential extends over the entire 165°C range of the part.

### Noise Considerations

The accuracy of the MAX6575L/H timeout delay is susceptible to noise generated both internally and externally. The effects of external noise can be minimized by placing a 0.1µF ceramic bypass capacitor close to the device's supply pin. Internal noise is inherent in the operation of the device and is detailed in Table 3. Internal averaging minimizes the effect of this noise when using longer timeout multipliers. The effects of this noise are included in the overall accuracy of the device as specified in the *Electrical Characteristics* table.

# SOT Temperature Sensor with Multidrop Single-Wire Digital Interface

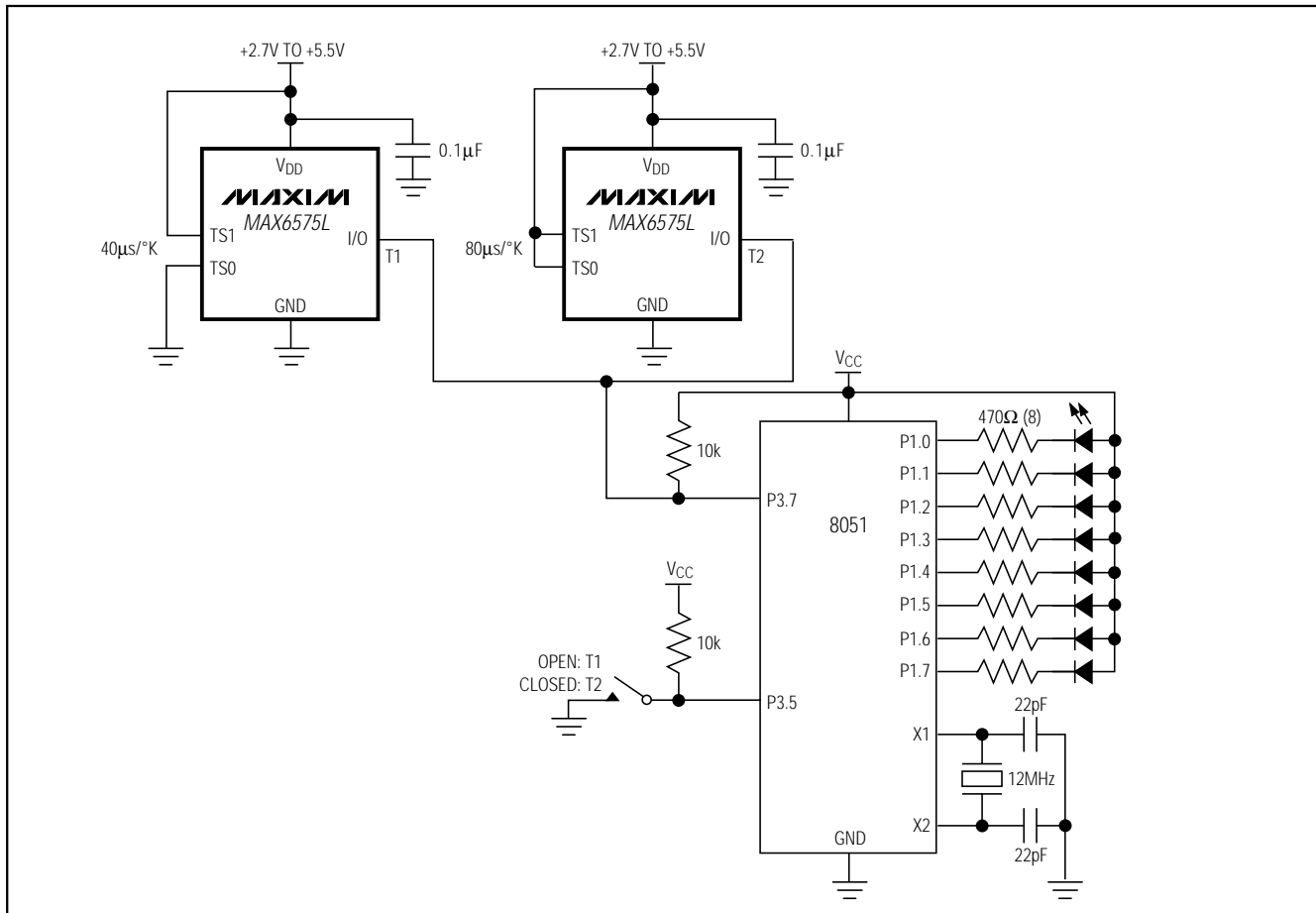

Figure 2. Interfacing Multiple Devices with a Microcontroller

## Interfacing Multiple Devices with a Microcontroller

Figure 2 shows how to interface multiple MAX6575L/H devices with an 8051 microcontroller. The first device, T1, is configured for a timeout multiplier of  $40\mu\text{s}/^\circ\text{K}$ , while the second device, T2, is configured for a timeout multiplier of  $80\mu\text{s}/^\circ\text{K}$  to avoid overlap. The microcontroller takes in temperature values from both sensors, T1 and T2, on a single port pin, P3.7. The microcontroller displays five times the temperature in degrees Celsius in binary on Port 1. A switch connected to a pull-up resistor at Port 3.5 selects which temperature is displayed: open = T1, closed = T2. Code is provided for this application as Listing 1.

# SOT Temperature Sensor with Multidrop Single-Wire Digital Interface

MAX6575L/H

## Listing 1. 8051 Code Example

```

;*****
; Demonstration and test code for MAX6575 Temp to Delay
; Takes in temperature values from 2 sensors on single
; port pin, P3.7 and displays temp as 5 times C in binary on
; port 1. port 3.5 selects which temp displayed- H=1, L=2.
; example: room temp= 21 C, display 105 or 01101001 on P1
;*****
;EQUATES
TEMP1H      EQU    10H          ;TEMPERATURE 1
TEMP1L      EQU    11H
TEMP2H      EQU    12H          ;TEMPERATURE 2
TEMP2L      EQU    13H

D1          EQU    30H          ;delay scratch registers
D2          EQU    31H
D3          EQU    32H

;PINS
IOPIN      BIT    P3.7          ;single pin interface
SLCT       BIT    P3.5          ;select display 1/2= H/L
;MAIN
          ORG    0              ;note one isr's used- timer overflow
          AJMP  BEGIN          ;jump over isr's

          ORG    0BH           ;timer 0 overflow- error
          CLR   TF0            ;clear timer overflow
          POP   ACC            ;unstack return address
          POP   ACC            ;unstack return address
          PUSH  LOW(DOTMP)     ;return to top on error
          PUSH  HIGH(DOTMP)   ;return to top on error
          CLR   TR0            ;clear timer run
          RETI                 ;error

          org    30h
BEGIN:     MOV   SP,#70h       ;set sp at 70H
;setup timer0 to do timing
          MOV   TMOD,#01H     ;t0 timer 16 bit
          MOV   IE,#82H       ;enable tf0 irq- error
;
;inits done- measure 2 temps
DOTMP:    MOV   TH0,#0        ;zero counter
          MOV   TL0,#0        ;zero counter
          SETB  TR0           ;start timer
          CLR   IOPIN         ;write pin low- start
          CALL  DLYP1         ;100 uS min low
          SETB  IOPIN         ;bring high
;do temp 1
          MOV   R0,#TEMP1H    ;point at temp1- high byte
          CALL  GTTP          ;get temp1
;do temp 2
          MOV   R0,#TEMP2H    ;point at temp2- high byte
          CALL  GTTP          ;get temp2

          CLR   TR0           ;stop timer- acquisition done

```

# SOT Temperature Sensor with Multidrop Single-Wire Digital Interface

## Listing 1. 8051 Code Example (continued)

```

; 2 temps are stored- display bin value of selected on P1
; temps are 40T,80T- times are in us

        MOV   R0,#TEMP1L      ;get temp1- low byte (40T)
        MOV   R4,#3           ;shift right 3x for 5x temp, div 8
        CALL  TMTOC           ;convert delay to degrees C x 5
        JNB   P3.5,DSP2       ;if select low, display temp2
        MOV   A,TEMP1L        ;get temperature
        CPL   A                ;invert it for active low led's
        MOV   P1,A            ;display this temp

DSP2:    MOV   R0,#TEMP2L      ;get temp2- low byte (80T)
        MOV   R4,#4           ;shift right 4x for 5x temp, div 16
        CALL  TMTOC           ;convert delay to degrees C x 5
        JB    P3.5,DSP1       ;if select high, display temp1 above
        MOV   A,TEMP2L        ;get temperature
        CPL   A                ;invert it for active low led's
        MOV   P1,A            ;display this temp

;done

;wait for 600 ms and do it again
DSP1:    MOV   D3,#60
DLL1:    MOV   D2,#100
DLL2:    MOV   D1,#50         ;inner loop
DLLLP:   DJNZ  D1,DLLLP       ;loop 100 us
        DJNZ  D2,DLL2         ;loop 10 ms
        DJNZ  D3,DLL1         ;loop 600ms
        JMP   DOTMP          ;loop forever

;*****
;subroutines
;*****
;GET TEMP- main, capture timer0 to @r0 after pin low edge
GTFP:    JB    IOPIN,GTFP      ;wait for low- irq gets hangs
        MOV   A,TH0           ;get high- quick
        MOV   B,TLO           ;get low- quick
        CJNE  A,TH0,ROLL      ;check rollover msb
        JMP   NOROL           ;no
ROLL:    MOV   A,TH0           ;get high again
        MOV   B,TLO           ;get low again
NOROL:   MOV   @R0,A          ;stash msb
        INC   R0               ;point next
        MOV   @R0,B          ;stash lsb
WAITH:   JNB   IOPIN,WAITH    ;wait for low- irq gets hangs
        RET

;sub; converts uS to degrees c x 5, R4 is # of right shifts
TMTOC:   CALL  SHRO           ;shift right
        DJNZ  R4,TMTOC        ;loop til shifted= 5x
        MOV   A,@R0           ;get x5 lsb
        CLR   C                ;ready for subb
        SUBB  A,#055H         ;low byte of 273 x 5- offset
        MOV   @R0,A          ;stash back
        DEC   R0               ;point hi
        MOV   A,@R0           ;get hi- prop carry

```



# SOT Temperature Sensor with Multidrop Single-Wire Digital Interface

MAX6575L/H

Listing 1. 8051 Code Example (continued)

```

                SUBB  A,#05H           ;sub high of 273 x 5- offset
                MOV   @R0,A           ;stash back- degrees c x 5 in temp
                RET                    ;done

;shift right routine- "divide by 2" - point low on enter/exit
SHR0:          DEC   R0               ;point high
                MOV   A,@R0          ;get high
                CLR   C               ;roll 0 into msbit
                RRC   A               ;shift right
                MOV   @R0,A          ;stash back
                INC   R0               ;point low
                MOV   A,@R0          ;get low- prop carry
                RRC   A               ;shift right
                MOV   @R0,A          ;stash back
                RET                    ;pointing at lsb on exit

;short delay- 100 uS
DLYP1:         MOV   D1,#50           ;~100 uS
D1LP:          DJNZ  D1,D1LP          ;delay- also entry
                RET                    ;return after .1 ms

                END
    
```

## Pin Configuration

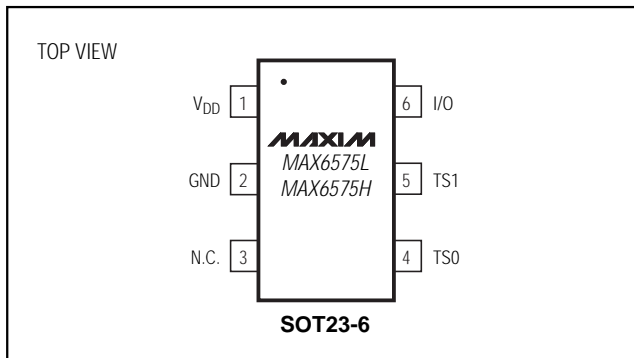

## Chip Information

TRANSISTOR COUNT: 302

# SOT Temperature Sensor with Multidrop Single-Wire Digital Interface

## Package Information

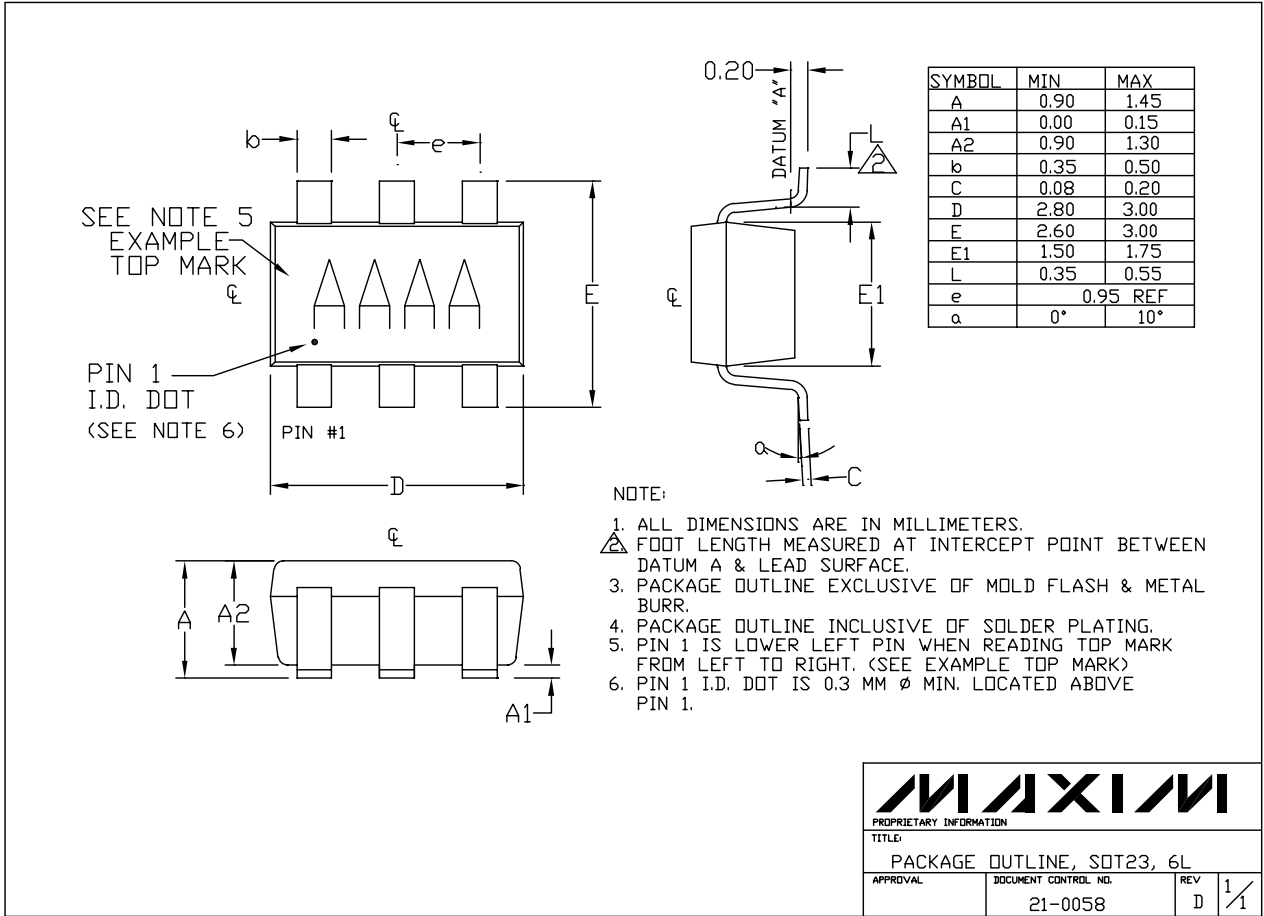

6LSOT23EPS

# *SOT Temperature Sensor with Multidrop Single-Wire Digital Interface*

## NOTES

MAX6575L/H

MAX6575L/H

# SOT Temperature Sensor with Multidrop Single-Wire Digital Interface

## NOTES

*Maxim cannot assume responsibility for use of any circuitry other than circuitry entirely embodied in a Maxim product. No circuit patent licenses are implied. Maxim reserves the right to change the circuitry and specifications without notice at any time.*

**12** \_\_\_\_\_ Maxim Integrated Products, 120 San Gabriel Drive, Sunnyvale, CA 94086 408-737-7600

© 1999 Maxim Integrated Products

Printed USA

**MAXIM** is a registered trademark of Maxim Integrated Products.