

LM73

2.7V, SOT-23, 11-to-14 Bit Digital Temperature Sensor with 2-Wire Interface

General Description

The LM73 is an integrated, digital-output temperature sensor featuring an incremental Delta-Sigma ADC with a two-wire interface that is compatible with the SMBus and I²C® interfaces. The host can query the LM73 at any time to read temperature. Available in a 6-pin SOT-23 package, the LM73 occupies very little board area while operating over a wide temperature range (-40°C to 150°C) and providing ±1.0°C accuracy from -10°C to 80°C. The user can optimize between the conversion time and the sensitivity of the LM73 by programming it to report temperature in any of four different resolutions. Defaulting to 11-bit mode (0.25°C/LSB), the LM73 measures temperature in a maximum time of 14 ms, making it ideal for applications that require temperature data very soon after power-up. In its maximum resolution, 14-bit mode (0.03125°C/LSB), the LM73 is optimized to sense very small changes in temperature.

A single multi-level address line selects one of three unique device addresses. An open-drain $\overline{\text{ALERT}}$ output goes active when the temperature exceeds a programmable limit. Both the data and clock lines are filtered for excellent noise tolerance and reliable communication. Additionally, a time-out feature on the clock and data lines causes the LM73 to automatically reset these lines if either is held low for an extended time, thus exiting any bus lock-up condition without processor intervention.

Applications

- Portable Electronics
- Notebook Computers
- Automotive
- System Thermal Management
- Office Electronics

Key Specifications

■ Supply Voltage		2.7V to 5.5V
■ Supply Current	operating	320 μA (typ)
		495 μA (max)
	shutdown	8 μA (max)
■ Temperature Accuracy		1.9 μA (typ)
	-10°C to 80°C	±1.0°C (max)
	-25°C to 115°C	±1.5°C (max)
■ Resolution		±2.0°C (max)
		0.25°C to 0.03125°C
■ Conversion Time	11-bit (0.25°C)	14 ms (max)
	14-bit (0.03125°C)	112 ms (max)

Features

- Single address pin offers choice of three selectable addresses per version for a total of six possible addresses.
- SMBus and I²C-compatible two-wire interface
- Supports 400 kHz operation
- Shutdown mode with one-shot feature available for very low average power consumption
- Programmable digital temperature resolution from 11 bits to 14 bits.
- Fast conversion rate ideal for quick power up and measuring rapidly changing temperature
- Open-drain $\overline{\text{ALERT}}$ output pin goes active when temperature is above a programmed temperature limit
- Very stable, low-noise digital output.
- UL Recognized Component 

Typical Application

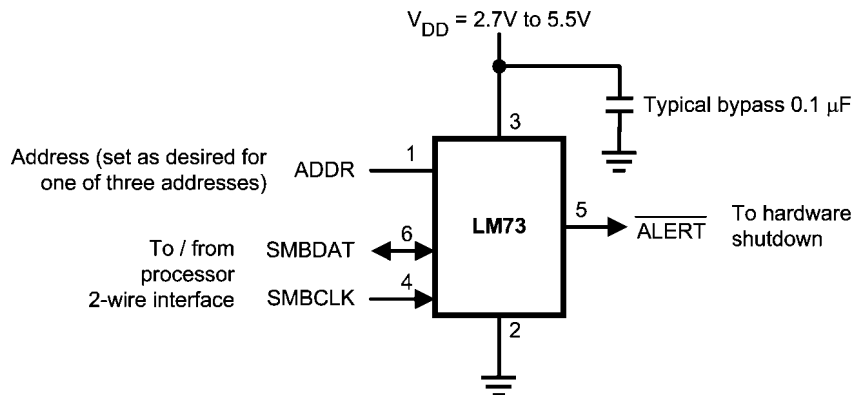

20147803

Simplified Block Diagram

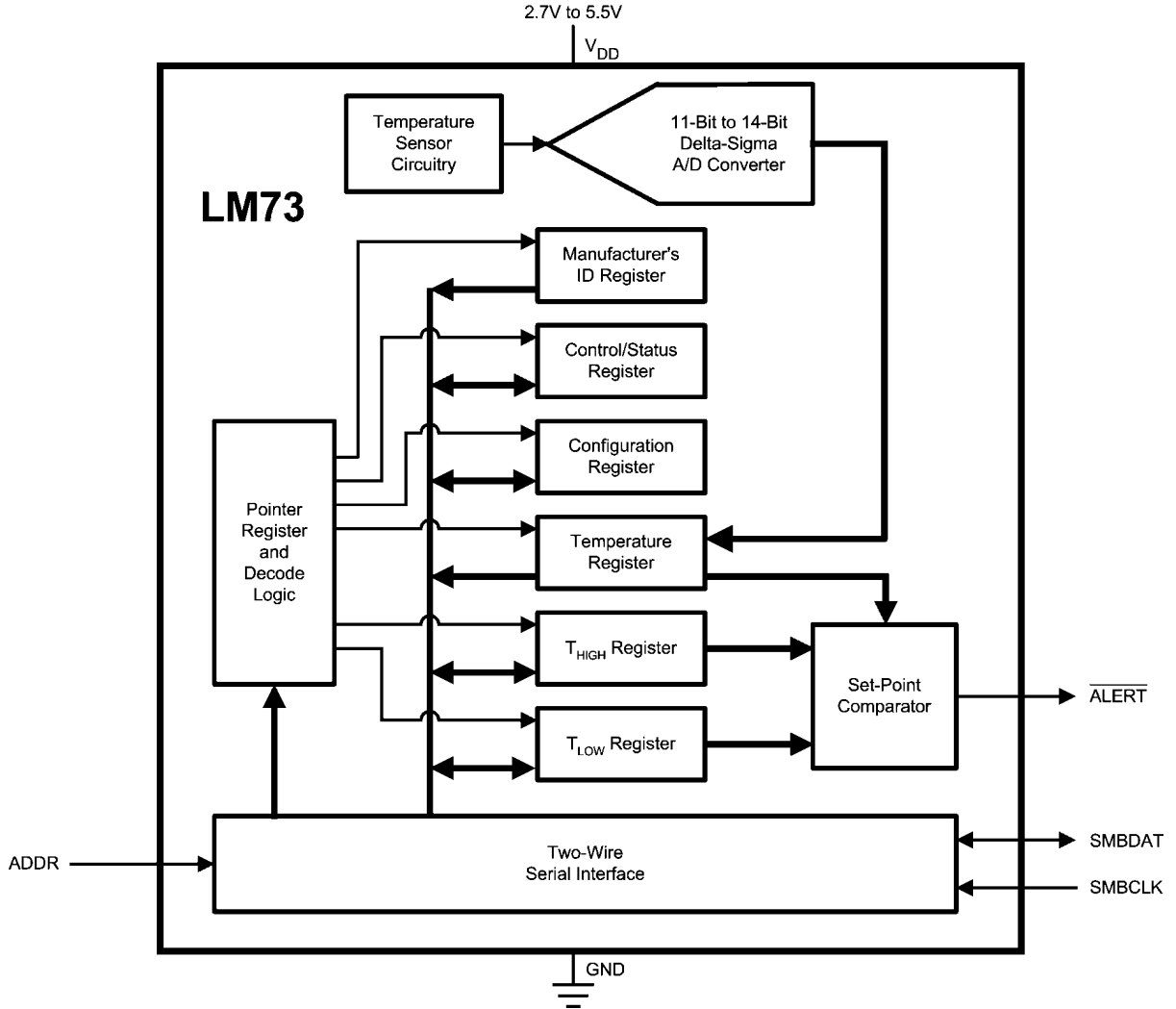

20147801

Connection Diagram

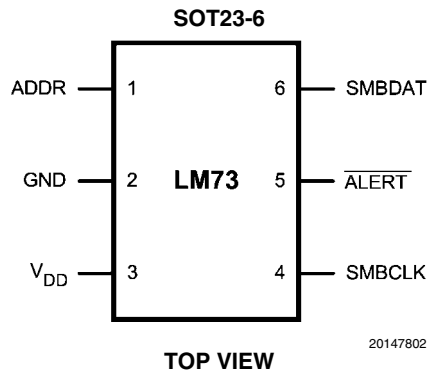

20147802

Ordering Information

Part Number	Package Marking	NS Package Number	Transport Media	SMBus Device Address	
				Address Pin	Device Address
LM73CIMK-0	T730	MK06A (Thin SOT23-6)	1000 Units on Tape and Reel	Float Ground V_{DD}	1001 000 1001 001 1001 010
LM73CIMKX-0	T730	MK06A (Thin SOT23-6)	3000 Units on Tape and Reel	Float Ground V_{DD}	1001 000 1001 001 1001 010
LM73CIMK-1	T731	MK06A (Thin SOT23-6)	1000 Units on Tape and Reel	Float Ground V_{DD}	1001 100 1001 101 1001 110
LM73CIMKX-1	T731	MK06A (Thin SOT23-6)	3000 Units on Tape and Reel	Float Ground V_{DD}	1001 100 1001 101 1001 110

Note 1: Available in RoHS-compliant packages. More details at www.national.com.

Pin Descriptions

Label	Pin #	Type	Equivalent Circuit	Function
ADDR	1	CMOS Logic Input (three levels)		Address Select Input: One of three device addresses is selected by connecting to ground, left floating, or connecting to V_{DD} .
GND	2	Ground		Ground
V_{DD}	3	Power		Supply Voltage
SMBCLK	4	CMOS Logic Input		Serial Clock: SMBus clock signal. Operates up to 400 kHz. Low-pass filtered.
ALERT	5	Open-Drain Output		Digital output which goes active whenever the measured temperature exceeds a programmable temperature limit.
SMBDAT	6	Open-Drain Input/Output		Serial Data: SMBus bi-directional data signal used to transfer serial data synchronous to the SMBCLK. Low-pass filtered.

Absolute Maximum Ratings (Note 2)

Supply Voltage	-0.3 V to 6.0 V
Voltage at SMBCLK and SMBDAT pins	-0.3 V to 6.0 V
Voltage at All Other Pins	-0.3 V to $(V_{DD} + 0.5 \text{ V})$ and $\leq 6.0 \text{ V}$
Input Current at Any Pin (Note 3)	$\pm 5 \text{ mA}$
Storage Temperature	-65°C to $+150^{\circ}\text{C}$
ESD Susceptibility (Note 5)	
Human Body Model	2000 V
Machine Model	200 V

Soldering process must comply with National Semiconductor's Reflow Temperature Profile specifications. Refer to www.national.com/packaging. (Note 4)

Operating Ratings

(Note 2)

Specified Temperature Range	$T_{MIN} \leq T_A \leq T_{MAX}$ $-40^{\circ}\text{C} \leq T_A \leq +150^{\circ}\text{C}$
Supply Voltage Range (V_{DD})	+2.7V to +5.5V

Temperature-to-Digital Converter Characteristics

Unless otherwise noted, these specifications apply for $V_{DD} = 2.7\text{V}$ to 5.5V . **Boldface limits apply for $T_A = T_J = T_{MIN}$ to T_{MAX}** ; all other limits $T_A = T_J = +25^{\circ}\text{C}$, unless otherwise noted. T_A is the ambient temperature. T_J is the junction temperature.

Parameter	Conditions	Typical (Note 6)	LM73C Limits (Note 7)	Units (Limit)
Accuracy (Note 8)	$V_{DD} = 2.7\text{V}$ to $V_{DD} = 4.5\text{V}$	$T_A = -10^{\circ}\text{C}$ to 80°C		± 1.0 °C (max)
		$T_A = -25^{\circ}\text{C}$ to 115°C		± 1.5 °C (max)
	$V_{DD} > 4.5\text{V}$ to $V_{DD} = 5.5\text{V}$	$T_A = -40^{\circ}\text{C}$ to 150°C		± 2.0 °C (max)
		$T_A = -10^{\circ}\text{C}$ to 80°C		± 1.5 °C (max)
		$T_A = -25^{\circ}\text{C}$ to 115°C		± 2.0 °C (max)
		$T_A = -40^{\circ}\text{C}$ to 150°C		± 2.5 °C (max)
Resolution	RES1 Bit = 0, RES0 Bit = 0	11		Bits
		0.25		°C/LSB
	RES1 Bit = 0, RES0 Bit = 1	12		Bits
		0.125		°C/LSB
	RES1 Bit = 1, RES0 Bit = 0	13		Bits
		0.0625		°C/LSB
RES1 Bit = 1, RES0 Bit = 1	14		Bits	
	0.03125		°C/LSB	
Temperature Conversion Time (Note 9)	RES1 Bit = 0, RES0 Bit = 0	10.1	14	ms (max)
	RES1 Bit = 0, RES0 Bit = 1	20.2	28	ms (max)
	RES1 Bit = 1, RES0 Bit = 0	40.4	56	ms (max)
	RES1 Bit = 1, RES0 Bit = 1	80.8	112	ms (max)
Quiescent Current	Continuous Conversion Mode, SMBus inactive	320	495	μA (max)
	Shutdown, bus-idle timers on	120	175	μA (max)
	Shutdown, bus-idle timers off	1.9	8	μA (max)
Power-On Reset Threshold	Measured on V_{DD} input, falling edge		0.9	V (min)

Logic Electrical Characteristics

DIGITAL DC CHARACTERISTICS

Unless otherwise noted, these specifications apply for $V_{DD} = 2.7V$ to $5.5V$. **Boldface limits apply for $T_A = T_J = T_{MIN}$ to T_{MAX}** ; all other limits $T_A = T_J = +25^\circ C$, unless otherwise noted. T_A is the ambient temperature. T_J is the junction temperature.

Symbol	Parameter	Conditions	Typical (Note 6)	Limits (Note 7)	Units (Limit)
SMBDAT, SMBCLK INPUTS					
V_{IH}	Logical "1" Input Voltage			$0.7 \cdot V_{DD}$	V (min)
V_{IL}	Logical "0" Input Voltage			$0.3 \cdot V_{DD}$	V (max)
$V_{IN,HYST}$	SMBDAT and SMBCLK Digital Input Hysteresis		$0.07 \cdot V_{DD}$		V
I_{IH}	Logical "1" Input Current	$V_{IN} = V_{DD}$	0.01	2	μA (max)
I_{IL}	Logical "0" Input Current	$V_{IN} = 0 V$	-0.01	-2	μA (max)
C_{IN}	Input Capacitance		5		pF
SMBDAT, ALERT OUTPUTS					
I_{OH}	High Level Output Current	$V_{OH} = V_{DD}$	0.01	2	μA (max)
V_{OL}	SMBus Low Level Output Voltage	$I_{OL} = 3 mA$		0.4	V (max)
ADDRESS INPUT					
$V_{IH,ADDRESS}$	Address Pin High Input Voltage			V_{DD} minus 0.100	V (min)
$V_{IL,ADDRESS}$	Address Pin Low Input Voltage			0.100	V (max)
$I_{IH,ADDRESS}$	Address Pin High Input Current	$V_{IN} = V_{DD}$	0.01	2	μA (max)
$I_{IL,ADDRESS}$	Address Pin Low Input Current	$V_{IN} = 0 V$	-0.01	-2	μA (max)

SMBus DIGITAL SWITCHING CHARACTERISTICS

Unless otherwise noted, these specifications apply for $V_{DD} = +2.7 V$ to $+5.5 V$, C_L (load capacitance) on output lines = 400 pF.

Boldface limits apply for $T_A = T_J = T_{MIN}$ to T_{MAX} ; all other limits $T_A = T_J = +25^\circ C$, unless otherwise noted.

Symbol	Parameter	Conditions	Typical (Note 6)	Limits (Note 7)	Units (Limit)
f_{SMB}	SMBus Clock Frequency	No minimum clock frequency if Time-Out feature is disabled.		400	kHz (max)
t_{LOW}	SMBus Clock Low Time			300	ns (min)
t_{HIGH}	SMBus Clock High Time			300	ns (min)
$t_{F,SMB}$	Output Fall Time (Note 10)	$C_L = 400 pF$ $I_{PULL-UP} \leq 3 mA$		250	ns (max)
$t_{TIMEOUT}$	SMBDAT and SMBCLK Time Low for Reset of Serial Interface (Note 11)			15 45	ms (min) ms (max)
$t_{SU,DAT}$	Data In Setup Time to SMBCLK High			100	ns (min)
$t_{HD,DATI}$	Data Hold Time: Data In Stable after SMBCLK Low			0	ns (min)
$t_{HD,DATO}$	Data Hold Time: Data Out Stable after SMBCLK Low			30	ns (min)
$t_{HD,STA}$	Start Condition SMBDAT Low to SMBCLK Low (Start condition hold before the first clock falling edge)			60	ns (min)
$t_{SU,STO}$	Stop Condition SMBCLK High to SMBDAT Low (Stop Condition Setup)			50	ns (min)
$t_{SU,STA}$	SMBus Repeated Start-Condition Setup Time, SMBCLK High to SMBDAT Low			50	ns (min)
t_{BUF}	SMBus Free Time Between Stop and Start Conditions			1.2	μs (min)
t_{POR}	Power-On Reset Time (Note 12)			1	ms (max)

SMBus Communication

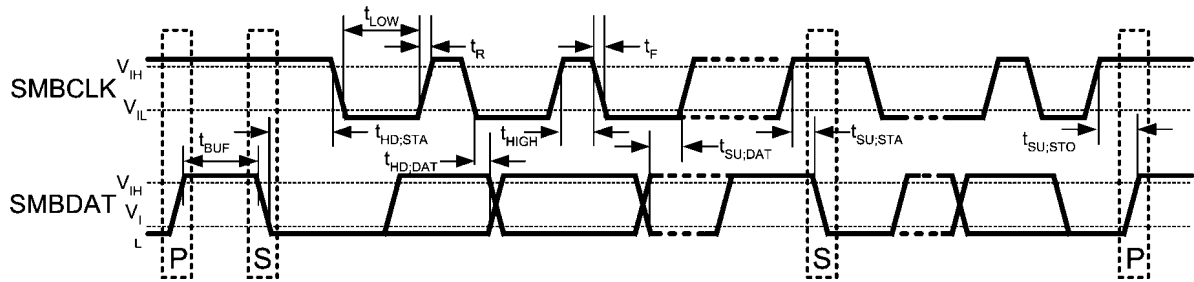

20147809

Note 2: Absolute Maximum Ratings indicate limits beyond which damage to the device may occur. DC and AC electrical specifications do not apply when operating the device beyond its rated operating conditions.

Note 3: When the input voltage (V_I) at any pin exceeds the power supplies ($V_I < \text{GND}$ or $V_I > V_{DD}$), the current at that pin should be limited to 5 mA.

Note 4: Reflow temperature profiles are different for lead-free and non-lead-free packages.

Note 5: Human body model, 100 pF discharged through a 1.5 k Ω resistor. Machine model, 200 pF discharged directly into each pin.

Note 6: Typical values are at $T_A = 25^\circ\text{C}$ and represent most likely parametric norm.

Note 7: Limits are guaranteed to National's AOQL (Average Outgoing Quality Level).

Note 8: Local temperature accuracy does not include the effects of self-heating. The rise in temperature due to self-heating is the product of the internal power dissipation of the LM73 and the thermal resistance.

Note 9: This specification is provided only to indicate how often temperature data is updated. The LM73 can be read at any time without regard to conversion state (and will yield last conversion result).

Note 10: The output fall time is measured from ($V_{IH,MIN} + 0.15\text{V}$) to ($V_{IL,MAX} - 0.15\text{V}$).

Note 11: Holding the SMBDAT and/or SMBCLK lines Low for a time interval greater than $t_{TIMEOUT}$ will reset the LM73's SMBus state machine, setting SMBDAT and SMBCLK pins to a high impedance state.

Note 12: Represents the time from V_{DD} reaching the power-on-reset level to the LM73 communications being functional. After an additional time equal to one temperature conversion time, valid temperature will be available in the Temperature Register.

Note 13: A write to an invalid pointer address is not allowed. If the master writes an invalid address to the Pointer Register, (1) the LM73 will not acknowledge the address and (2) the Pointer Register will continue to contain the last value stored in it.

Typical Performance Characteristics

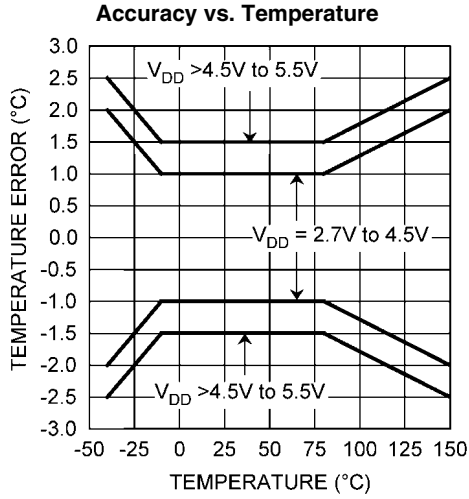

20147820

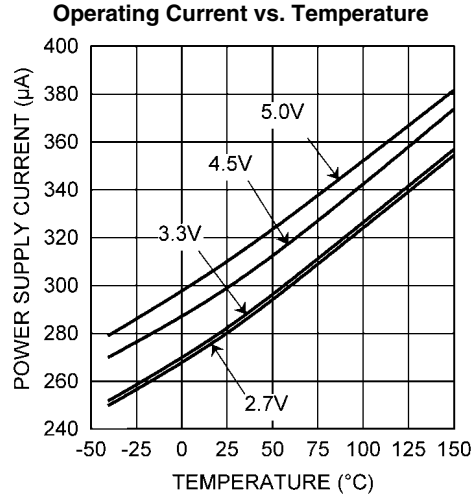

20147821

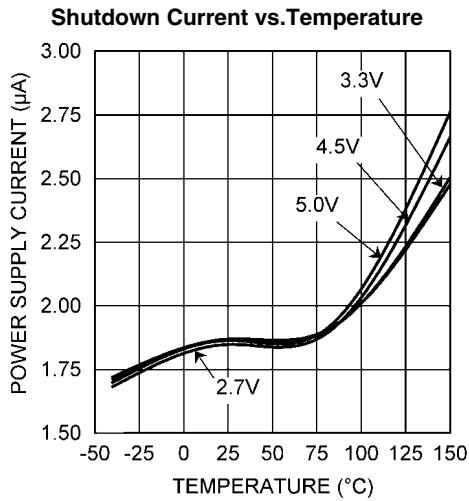

20147822

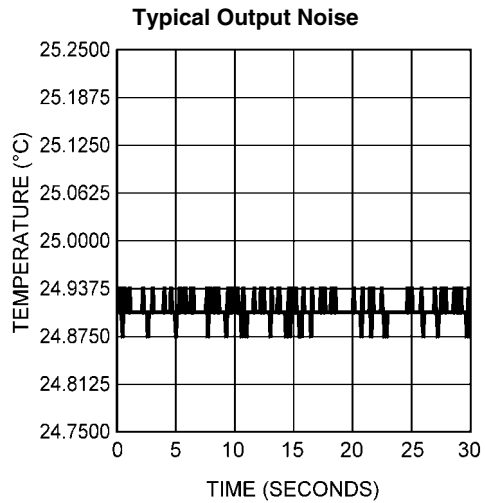

20147823

1.0 Functional Description

The LM73 is a digital temperature sensor that senses the temperature of its die using a sigma-delta analog-to-digital converter and stores the temperature in the Temperature Register. The LM73's 2-wire serial interface is compatible with SMBus 2.0 and I²C. Please see the SMBus 2.0 specification for a detailed description of the differences between the I²C bus and SMBus.

The temperature resolution is programmable, allowing the host system to select the optimal configuration between sensitivity and conversion time. The LM73 can be placed in shutdown to minimize power consumption when temperature data is not required. While in shutdown, a 1-shot conversion mode allows system control of the conversion rate for ultimate flexibility.

The LM73 features the following registers. See Section 2.0 for a complete list of the pointer address, content, and reset state of each register.

1. Pointer Register
2. Temperature Register
3. Configuration Register
4. T_{HIGH} Register
5. T_{LOW} Register
6. Control/Status Register
7. Identification Register

1.1 POWER-ON RESET

The power-on reset (POR) state is the point at which the supply voltage rises above the power-on reset threshold (specified in the electrical specifications table), generating an internal reset. Each of the registers contains a defined value upon POR and this data remains there until any of the following occurs:

1. The first temperature conversion is completed, causing the Temperature Register and various status bits to be updated internally, depending on the value of the measured temperature.
2. The master writes different data to any Read/Write (R/W) bits, or
3. The LM73 is powered down.

1.2 ONE-SHOT CONVERSION

The LM73 features a one-shot conversion bit, which is used to initiate a single conversion and comparison cycle when the LM73 is in shutdown mode. While the LM73 is in shutdown mode, writing a "1" to the One-Shot bit in the Configuration Register will cause the LM73 to perform a single temperature conversion and update the Temperature Register and the affected status bits. Operating the LM73 in this one-shot mode allows for extremely low average-power consumption, making it ideal for low-power applications.

When the One-Shot bit is set, the LM73 initiates a temperature conversion. After this initiation, but before the completion of the conversion and resultant register updates, the LM73 is in a "one-shot" state. During this state, the Data Available (DAV) flag in the Control/Status register is "0" and the Tem-

perature Register contains the value 8000h (-256°C). All other registers contain the data that was present before initiating the one-shot conversion. After the temperature measurement is complete, the DAV flag will be set to "1" and the temperature register will contain the resultant measured temperature.

1.3 TEMPERATURE DATA FORMAT

The resolution of the temperature data and the size of the data word are user-selectable through bits RES1 and RES0 in the Control/Status Register. By default, the LM73 temperature stores the measured temperature in an 11-bit (10 bits plus sign) word with one least significant bit (LSB) equal to 0.25° C. The maximum word size is 14 bits (13-bits plus sign) with a resolution of 0.03125 °C/LSB.

CONTROL BIT		DATA FORMAT	
RES1	RES0	WORD SIZE	RESOLUTION
0	0	11 bits	0.25 °C/LSB
0	1	12 bits	0.125 °C/LSB
1	0	13 bits	0.0625 °C/LSB
1	1	14 bits	0.03125 °C/LSB

The temperature data is reported in 2's complement format. The word is stored in the 16-bit Temperature Register and is left justified in this register. Unused temperature-data bits are always reported as "0".

11-bit (10-bit plus Sign)

Temperature	Digital Output	
	Binary	Hex
+150°C	0100 1011 0000 0000	4B00h
+25°C	0000 1100 1000 0000	0C80h
+1°C	0000 0000 1000 0000	0080h
+0.25°C	0000 0000 0010 0000	0020h
0°C	0000 0000 0000 0000	0000h
-0.25°C	1111 1111 1110 0000	FFE0h
-1°C	1111 1111 1000 0000	FF80h
-25°C	1111 0011 1000 0000	F380h
-40°C	1110 1100 0000 0000	EC00h

12-bit (11-bit plus Sign)

Temperature	Digital Output	
	Binary	Hex
+150°C	0100 1011 0000 0000	4B00h
+25°C	0000 1100 1000 0000	0C80h
+1°C	0000 0000 1000 0000	0080h
+0.125°C	0000 0000 0001 0000	0010h
0°C	0000 0000 0000 0000	0000h
-0.125°C	1111 1111 1111 0000	FFF0h
-1°C	1111 1111 1000 0000	FF80h
-25°C	1111 0011 1000 0000	F380h
-40°C	1110 1100 0000 0000	EC00h

13-bit (12-bit plus Sign)

Temperature	Digital Output	
	Binary	Hex
+150°C	0100 1011 0000 0000	4B00h
+25°C	0000 1100 1000 0000	0C80h
+1°C	0000 0000 1000 0000	0080h
+0.0625°C	0000 0000 0000 1000	0008h
0°C	0000 0000 0000 0000	0000h
-0.0625°C	1111 1111 1111 1000	FFF8h
-1°C	1111 1111 1000 0000	FF80h
-25°C	1111 0011 1000 0000	F380h
-40°C	1110 1100 0000 0000	EC00h

14-bit (13-bit plus Sign)

Temperature	Digital Output	
	Binary	Hex
+150°C	0100 1011 0000 0000	4B00h
+25°C	0000 1100 1000 0000	0C80h
+1°C	0000 0000 1000 0000	0080h
+0.03125°C	0000 0000 0000 0100	0004h
0°C	0000 0000 0000 0000	0000h
-0.03125°C	1111 1111 1111 1100	FFFC h
-1°C	1111 1111 1000 0000	FF80h
-25°C	1111 0011 1000 0000	F380h
-40°C	1110 1100 0000 0000	EC00h

1.4 SMBus INTERFACE

The LM73 operates as a slave on the SMBus. The SMBDAT line is bidirectional. The SMBCLK line is an input only. The LM73 never drives the SMBCLK line and it does not support clock stretching.

The LM73 uses a 7-bit slave address. It is available in two versions. Each version can be configured for one of three unique slave addresses, for a total of six unique address.

Part Number	Address Pin	Device Address
LM73-0	Float	1001 000
	Ground	1001 001
	V_{DD}	1001 010
LM73-1	Float	1001 100
	Ground	1001 101
	V_{DD}	1001 110

The SMBDAT output is an open-drain output and does not have internal pull-ups. A "high" level will not be observed on this pin until pull-up current is provided by some external source, typically a pull-up resistor. Choice of resistor value depends on many system factors but, in general, the pull-up resistor should be as large as possible without effecting the SMBus desired data rate. This will minimize any internal temperature reading errors due to internal heating of the LM73.

The LM73 features an integrated low-pass filter on both the SMBCLK and the SMBDAT line. These filters increase communications reliability in noisy environments.

If either the SMBCLK or SMBDAT line is held low for a time greater than $t_{TIMEOUT}$ (see Logic Electrical Characteristics for the value of $t_{TIMEOUT}$), the LM73 state machine will reset to the

SMBus idle state, releasing the data line. Once the SMBDAT is released high, the master may initiate an SMBus start.

1.5 ALERT FUNCTION

The \overline{ALERT} output is an over-temperature indicator. At the end of every temperature conversion, the measured temperature is compared to the value in the T_{HIGH} Register. If the measured temperature exceeds the value stored in T_{HIGH} , the \overline{ALERT} output goes active (see Figure 1). This over-temperature condition will also cause the ALRT_STAT bit in the Control/Status Register to change value (this bit mirrors the logic level of the \overline{ALERT} pin).

The \overline{ALERT} pin and the ALRT_STAT bit are cleared when any of the following occur:

1. The measured temperature falls below the value stored in the T_{LOW} Register
2. A "1" is written to the \overline{ALERT} Reset bit in the Configuration Register
3. The master resets it through an SMBus Alert Response Address (ARA) procedure

If \overline{ALERT} has been cleared by the master writing a "1" to the \overline{ALERT} Reset bit, while the measured temperature still exceeds the T_{HIGH} setpoint, \overline{ALERT} will go active again after the completion of the next temperature conversion.

Each temperature reading is associated with a Temperature High (THI) and a Temperature Low (TLOW) flag in the Control/Status Register. A digital comparison determines whether that reading is above the T_{HIGH} setpoint or below the T_{LOW} setpoint. If so, the corresponding flag is set. All digital comparisons to the T_{HIGH} and T_{LOW} values are based on an 11-bit temperature comparison. Regardless of the resolution setting of the LM73, the lower three temperature LSBs will not affect the state of the \overline{ALERT} output, THI flag, and TLOW flag.

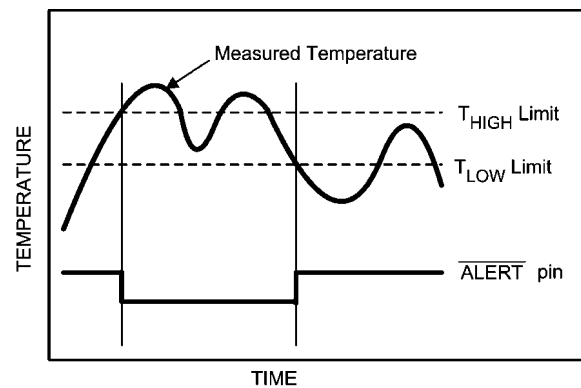

20147816

FIGURE 1. \overline{ALERT} Temperature Response cleared when temperature crosses T_{LOW}

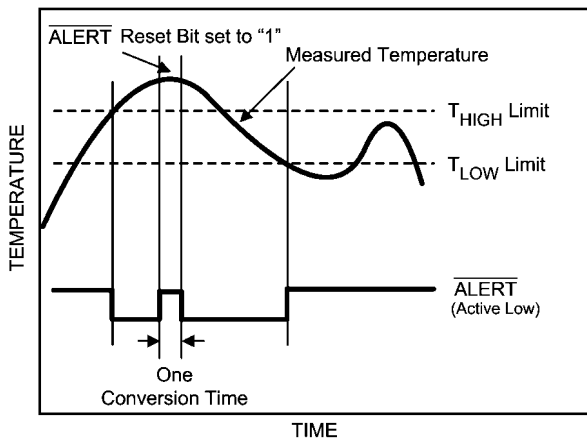

20147817

FIGURE 2. ALERT Temperature Response cleared by writing a "1" to the ALERT Reset Bit.

1.6 COMMUNICATING WITH THE LM73

The data registers in the LM73 are selected by the Pointer Register. At power-up the Pointer Register is set to "00h", the

location for the Temperature Register. The Pointer Register latches the last location it was set to. Note that all Pointer Register bits are decoded; any incorrect pointer values will not be acknowledged and will not be stored in the Pointer Register (Note 13).

A **Write** to the LM73 will always include the address byte and the pointer byte.

A **Read** from the LM73 can take place either of two ways:

1. If the location latched in the Pointer Register is correct (that is, the Pointer Register is pre-set prior to the read), then the read can simply consist of an address byte, followed by retrieving the data byte. Most of the time it is expected that the Pointer Register will point to Temperature Registers because that will be the data most frequently read from the LM73.
2. If the Pointer Register needs to be set, then an address byte, pointer byte, repeat start, and another address byte will accomplish a read.

The data byte is read out of the LM73 by the most significant bit first. At the end of a read, the LM73 can accept either an Acknowledge or No Acknowledge bit from the Master. No Acknowledge is typically used as a signal to the slave that the Master has read its last byte.

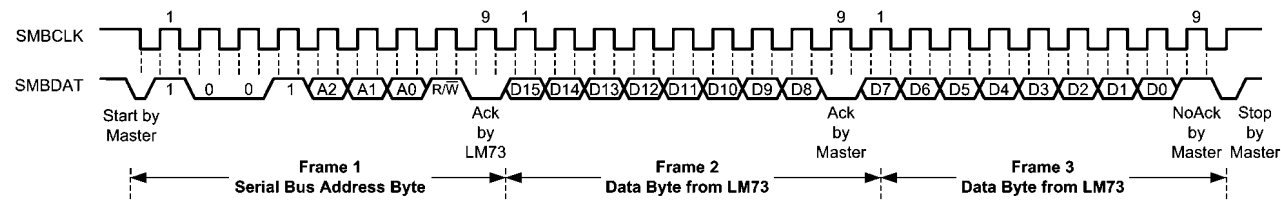

20147810

(a) Typical Read from a 2-Byte Register with Preset Pointer

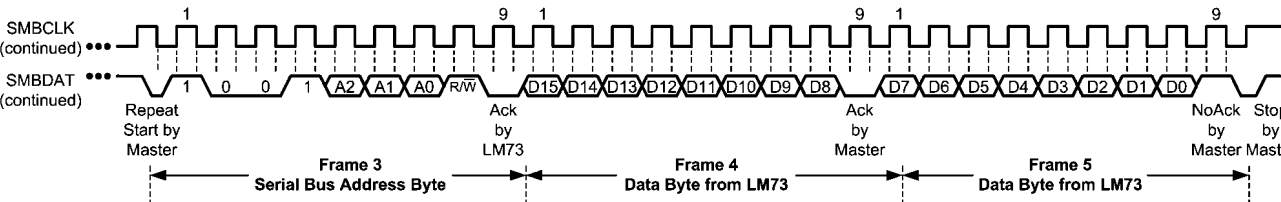
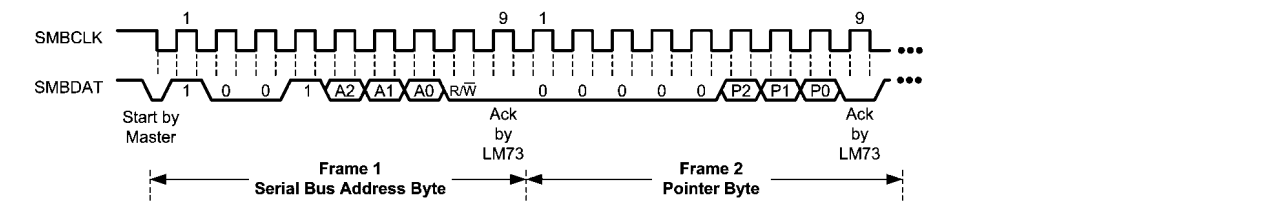

20147811

(b) Typical Pointer Set Followed by Immediate Read of a 2-Byte Register

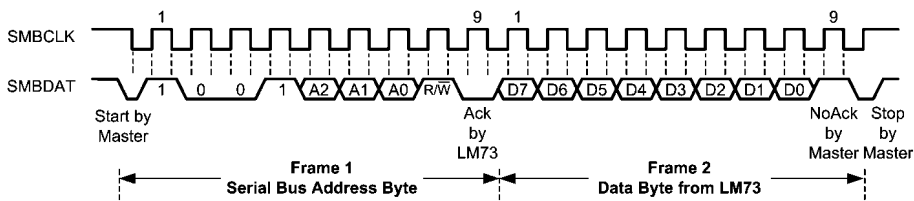

20147812

(c) Typical Read from a 1-Byte Register with Preset Pointer

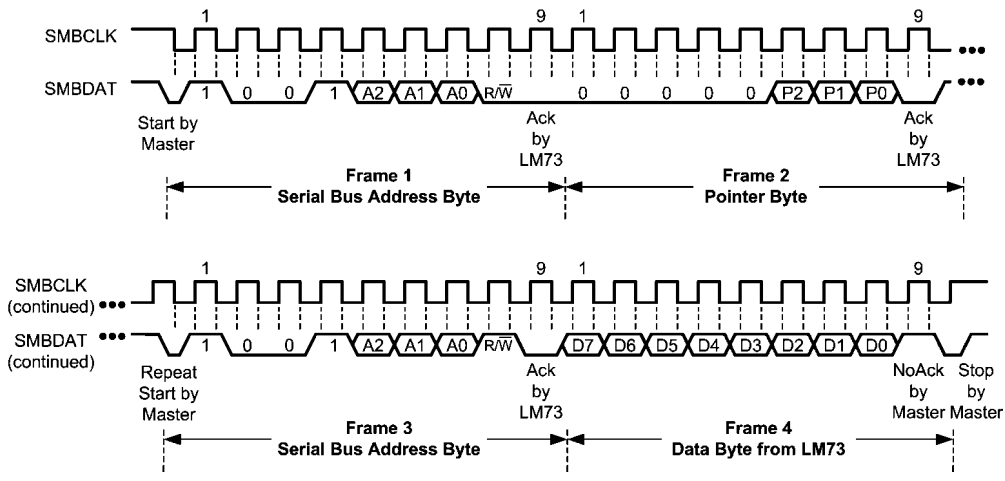

(d) Typical Pointer Set Followed by Immediate Read of a 1-Byte Register.

FIGURE 3. Reading from the LM73

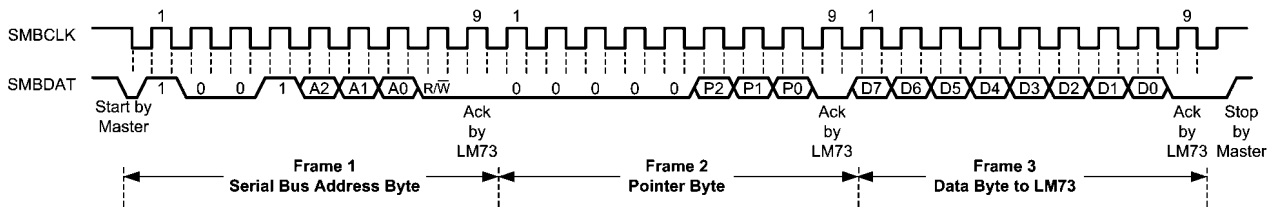

(a) Typical 1-Byte Write

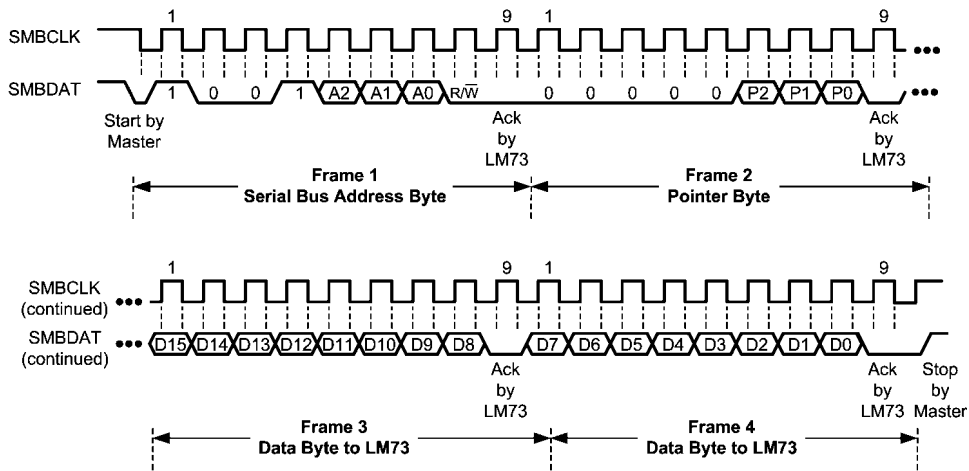

(b) Typical 2-Byte Write

FIGURE 4. Writing to the LM73

1.7 SHUTDOWN MODE

Shutdown Mode is enabled by writing a “1” to the Full Power Down Bit, Bit 7 of the Configuration Register, and holding it high for at least the specified maximum conversion time at the existing temperature resolution setting. (see Temperature Conversion Time specifications under the Temperature-to-Digital Characteristics section). For example, if the LM73 is set for 12-bit resolution before shutdown, then Bit 7 of the

Configuration register must go high and stay high for the specified maximum conversion time for 12-bits resolution. The LM73 will always finish a temperature conversion and update the temperature registers before shutting down. Writing a “0” to the Full Power Down Bit restores the LM73 to normal mode. The user should wait at least the specified maximum conversion time, at the existing resolution setting, before accurate data appears in the temperature register.

2.0 LM73 Registers

The LM73's internal registers are selected by the Pointer register. The Pointer register latches the last location that it was set to. The pointer register and all internal registers are described below. All registers reset at device power up.

2.1 POINTER REGISTER

The diagram below shows the Pointer Register, the six internal registers to which it points, and their associated pointer addresses.

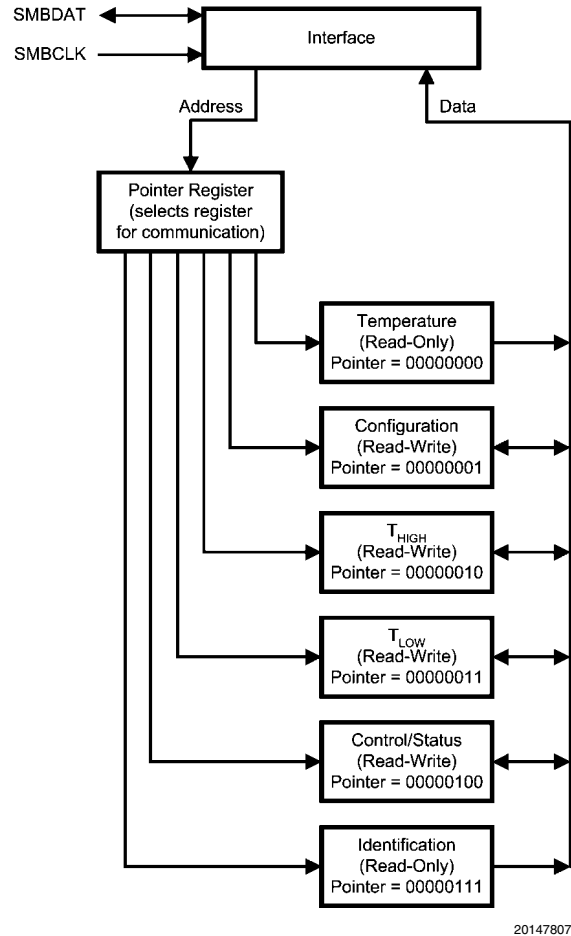

P7	P6	P5	P4	P3	P2	P1	P0
0	0	0	0	0	Register Select		

Bits	Name	Description
7:3	Not Used	Must write zeros only.
2:0	Register Select	Pointer address. Points to desired register. See table below.

P2	P1	P0	REGISTER (Note 13)
0	0	0	Temperature
0	0	1	Configuration
0	1	0	T_{HIGH}
0	1	1	T_{LOW}
1	0	0	Control / Status
1	1	1	Identification

2.2 TEMPERATURE DATA REGISTER

Pointer Address 00h (Read Only)

Reset State: 7FFCh (+255.96875°C)

One-Shot State: 8000h (-256°C)

D15	D14	D13	D12	D11	D10	D9	D8
SIGN	128°C	64°C	32°C	16°C	8°C	4°C	2°C

D7	D6	D5	D4	D3	D2	D1	D0
1°C	0.5°C	0.25°C	0.125°C	0.0625°C	0.03125°C	reserved	reserved

Bits	Name	Description
15:2	Temperature Data	Represents the temperature that was measured by the most recent temperature conversion. On Power-up, this data is invalid until the Data Available (DAV) bit in the Control/Status register is high (after the completion of the first temperature conversion). The resolution is user-programmable from 11-bit resolution (0.25°C/LSB) through 14-bit resolution (0.03125°C/LSB). The desired resolution is programmed with bits 5 and 6 of the Control/Status register.
1:0	Not Used	Return zeros upon read.

2.3 CONFIGURATION REGISTER

Pointer Address 01h (R/W)

Reset State: 40h

D7	D6	D5	D4	D3	D2	D1	D0
PD	reserved	$\overline{\text{ALRT EN}}$	ALRT POL	ALRT RST	ONE SHOT	reserved	

Bits	Name	Description
7	Full Power Down	Writing a "1" to this bit and holding it high for at least the specified maximum conversion time, at the existing temperature resolution setting, puts the LM73 in shutdown mode for power conservation. Writing a "0" to this bit restores the LM73 to normal mode. Waiting one specified maximum conversion time for the existing resolution setting assures accurate data in the temperature register.
6	reserved	User must write only a 1 to this bit
5	$\overline{\text{ALERT Enable}}$	A 0 in this location enables the $\overline{\text{ALERT}}$ output. A 1 disables it. This bit also controls the $\overline{\text{ALERT}}$ Status bit (the Control/Status Register, Bit 3) since that bit reflects the state of the Alert pin.
4	$\overline{\text{ALERT Polarity}}$	When set to 1, the $\overline{\text{ALERT}}$ pin and $\overline{\text{ALERT}}$ Status bit are active-high. When 0, it is active-low.
3	$\overline{\text{ALERT Reset}}$	Writing a 1 to this bit resets the $\overline{\text{ALERT}}$ pin and the $\overline{\text{ALERT}}$ Status bit. It will always be 0 when read.
2	One Shot	When in shutdown mode (Bit 7 is 1), initiates a single temperature conversion and update of the temperature register with new temperature data. Has no effect when in continuous conversion mode (i.e., when Bit 7 is 0). Always returns a 0 when read.
1:0	Reserved	User must write only a 0 to these bits.

2.4 T_{HIGH} UPPER-LIMIT REGISTER

Pointer Address 02h (R/W)

Reset State: 7FE0h (+255.75°C)

D15	D14	D13	D12	D11	D10	D9	D8
SIGN	128°C	64°C	32°C	16°C	8°C	4°C	2°C

D7	D6	D5	D4	D3	D2	D1	D0
1°C	0.5°C	0.25°C	reserved				

Bits	Name	Description
15:5	Upper-Limit Temperature	If the measured temperature that is stored in this register exceeds this user-programmable upper temperature limit, the $\overline{\text{ALERT}}$ pin will go active and the THIGH flag in the Control/Status register will be set to 1. Two's complement format.
4:0	Reserved	Returns zeros upon read. Recommend writing zeros only in these bits.

2.5 T_{LOW} LOWER-LIMIT REGISTER

Pointer Address 03h (R/W)

Reset State: 8000h (-256°C)

D15	D14	D13	D12	D11	D10	D9	D8
SIGN	128°C	64°C	32°C	16°C	8°C	4°C	2°C

D7	D6	D5	D4	D3	D2	D1	D0
1°C	0.5°C	0.25°C	reserved				

Bits	Name	Description
15:5	Lower-Limit Temperature	If the measured temperature that is stored in the temperature register falls below this user-programmable lower temperature limit, the $\overline{\text{ALERT}}$ pin will be deactivated and the T _{LOW} flag in the Control/Status register will be set to 1. Two's complement format.
4:0	Reserved	Returns zeros upon read. Recommend writing zeros only in these bits.

2.6 CONTROL/STATUS REGISTER

Pointer Address 04h (R/W)

Reset State: 08h

D7	D6	D5	D4	D3	D2	D1	D0
TO_DIS	RES1	RES0	reserved	ALRT_STAT	THI	TLOW	DAV

Bits	Name	Description
7	Time-Out Disable	Disable the time-out feature on the SMBDAT and SMBCLK lines if set to 1. Setting this bit turns off the bus-idle timers, enabling the LM73 to operate at lowest shutdown current.
6:5	Temperature Resolution	Selects one of four user-programmable temperature data resolutions 00: 0.25°C/LSB, 11-bit word (10 bits plus Sign) 01: 0.125°C/LSB, 12-bit word (11 bits plus Sign) 10: 0.0625°C/LSB, 13-bit word (12 bits plus Sign) 11: 0.03125°C/LSB, 14-bit word (13 bits plus Sign)
4	reserved	Always returns zero when read. Recommend customer write zero only.
3	$\overline{\text{ALERT}}$ Pin Status	Value is 0 when $\overline{\text{ALERT}}$ output pin is low. Value is 1 when $\overline{\text{ALERT}}$ output pin is high. The $\overline{\text{ALERT}}$ output pin is reset under any of the following conditions: (1) Cleared by writing a 1 to the $\overline{\text{ALERT}}$ Reset bit in the configuration register, (2) Measured temperature falls below the T _{LOW} limit, or (3) cleared via the ARA sequence. Recommend customer write zero only.

Bits	Name	Description
2	Temperature High Flag	Bit is set to 1 when the measured temperature exceeds the T_{HIGH} limit stored in the programmable T_{HIGH} register. Flag is reset to 0 when both of the following conditions are met: (1) measured temperature no longer exceeds the programmed T_{HIGH} limit <i>and</i> (2) upon reading the Control/Status register. If the temperature is not longer above the T_{HIGH} limit, this status bit remains set until it is read by the master so that the system can check the history of what caused the \overline{ALERT} output to go active. This bit is not cleared after every read if the measured temperature is still above the T_{HIGH} limit.
1	Temperature Low Flag	Bit is set to 1 when the measured temperature falls below the T_{LOW} limit stored in the programmable T_{LOW} register. Flag is reset to 0 when both of the following conditions are met: (1) measured temperature is no longer below the programmed T_{LOW} limit <i>and</i> (2) upon reading the Control/Status register. If the temperature is no longer below the T_{LOW} limit, the status bit remains set until it is read by the master so that the system can check the history of what cause the \overline{ALERT} output to go active. This bit is not cleared after every read if temperature is still below T_{LOW} limit.
0	Data Available Flag	This bit is 0 when the LM73 is in the process of converting a new temperature. It is 1 when the conversion is done. After initiating a temperature conversion while operating in the one-shot mode, this status bit can be monitored to indicate when the conversion is done. After triggering the one-shot conversion, the data in the temperature register is invalid until this bit is high (that is, after completion of the conversion). On power-up, the LM73 is in continuous conversion mode; while in continuous conversion mode (the default mode after power-on reset) this bit will always be high. Recommend customer write zero only.

2.7 IDENTIFICATION REGISTER

Pointer Address 07h (Read Only)

Reset State: 0190h

D15	D14	D13	D12	D11	D10	D9	D8
0	0	0	0	0	0	0	1

D7	D6	D5	D4	D3	D2	D1	D0
1	0	0	1	0	0	0	0

Bits	Name	Description
15:8	Manufacturer Identification Byte	Always returns 01h to uniquely identify the manufacturer as National Semiconductor Corporation.
7:4	Product Identification Nibble	Always returns 9h to uniquely identify this part as the LM73 Temperature Sensor.
3:0	Die Revision Step Nibble	Always returns 0h to uniquely identify the revision as level zero.

3.0 Application Hints

3.1 THERMAL PATH CONSIDERATIONS

To get the expected results when measuring temperature with an integrated circuit temperature sensor like the LM73, it is important to understand that the sensor measures its own die temperature. For the LM73, the best thermal path between the die and the outside world is through the LM73's pins. In the SOT23 package, all the pins on the LM73 will have an equal effect on the die temperature. Because the pins represent a good thermal path to the LM73 die, the LM73 will provide an accurate measurement of the temperature of the printed circuit board on which it is mounted. There is a less efficient thermal path between the plastic package and the LM73 die. If the ambient air temperature is significantly different from the printed circuit board temperature, it will have a small effect on the measured temperature.

3.2 OUTPUT CONSIDERATIONS: TIGHT ACCURACY, RESOLUTION AND LOW NOISE

The LM73 is well suited for applications that require tight temperature measurement accuracy. In many applications, the low temperature error can mean better system performance and, by eliminating a system calibration step, lower production cost.

With digital resolution as fine as 0.03125 °C/LSB, the LM73 senses and reports very small changes in its temperature, making it ideal for applications where temperature sensitivity is important. For example, the LM73 enables the system to quickly identify the direction of temperature change, allowing the processor to take compensating action before the system reaches a critical temperature.

The LM73 has very low output noise, typically 0.015°C rms, which makes it ideal for applications where stable thermal compensation is a priority. For example, in a temperature-compensated oscillator application, the very small deviation in successive temperature readings translates to a stable frequency output from the oscillator.

3.3 POWER SUPPLY RAMP-UP CONSIDERATIONS

In systems where there is a large amount of capacitance on the VDD node, the LM73 power supply ramp-up time can become excessively long. Slow power-supply ramp times may result in abnormal temperature readings. A linear power-on-ramp of less than 0.7V/msec and an exponential ramp with an RC time constant of more than 1.25 msec is categorized as a slow power-supply ramp. To avoid errors, use the power up sequence described below.

The software reset sequence is as follows:

1. Allow V_{DD} to reach the specified minimum operating voltage, as specified in the Operating Ratings section.
2. Write a "1" to the Full Power Down bit, Bit 7 of the Configuration Register, and hold it high for the specified maximum conversion time for the initial default of 11-bits resolution. This ensures that a complete reset operation has occurred. See the Temperature Conversion Time specifications within the Temperature-to-Digital Characteristics section for more details.
3. Write a "0" to the Full Power Down bit to restore the LM73 to normal mode.

Physical Dimensions inches (millimeters) unless otherwise noted

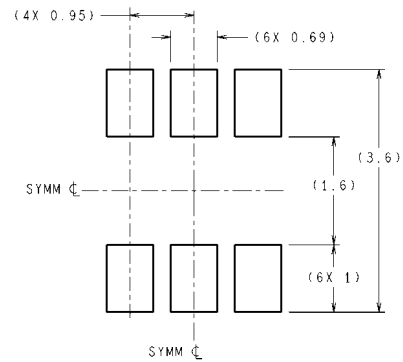
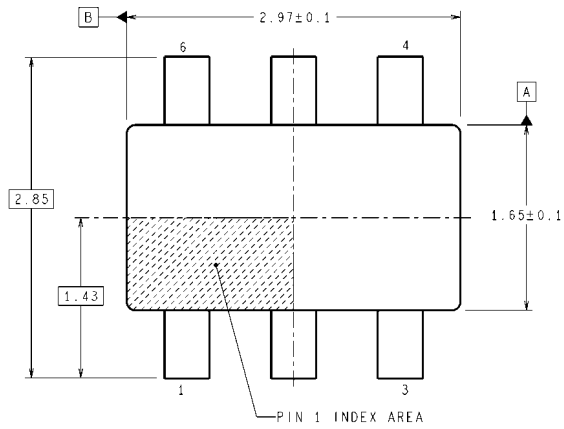

RECOMMENDED LAND PATTERN

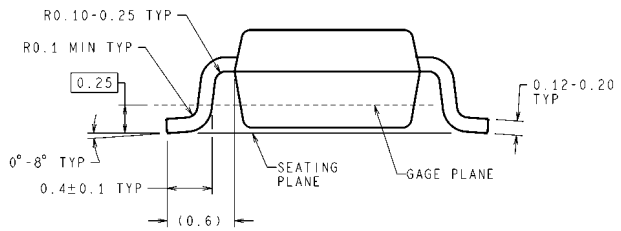
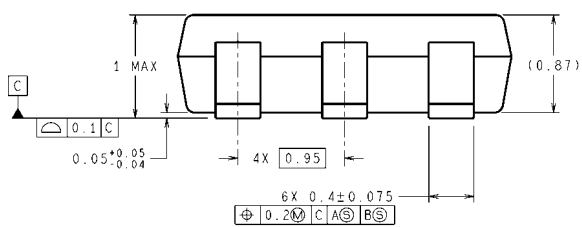

DIMENSIONS ARE IN MILLIMETERS

MK06A (Rev E)

**6-Lead Thin-SOT23,
Order Number LM73CIMK or LM73CIMKX
NS Package Number MK06A**

Notes

For more National Semiconductor product information and proven design tools, visit the following Web sites at:

Products		Design Support	
Amplifiers	www.national.com/amplifiers	WEBENCH® Tools	www.national.com/webench
Audio	www.national.com/audio	App Notes	www.national.com/appnotes
Clock and Timing	www.national.com/timing	Reference Designs	www.national.com/refdesigns
Data Converters	www.national.com/adc	Samples	www.national.com/samples
Interface	www.national.com/interface	Eval Boards	www.national.com/evalboards
LVDS	www.national.com/lvds	Packaging	www.national.com/packaging
Power Management	www.national.com/power	Green Compliance	www.national.com/quality/green
Switching Regulators	www.national.com/switchers	Distributors	www.national.com/contacts
LDOs	www.national.com/ldo	Quality and Reliability	www.national.com/quality
LED Lighting	www.national.com/led	Feedback/Support	www.national.com/feedback
Voltage Reference	www.national.com/vref	Design Made Easy	www.national.com/easy
PowerWise® Solutions	www.national.com/powerwise	Solutions	www.national.com/solutions
Serial Digital Interface (SDI)	www.national.com/sdi	Mil/Aero	www.national.com/milaero
Temperature Sensors	www.national.com/tempensors	SolarMagic™	www.national.com/solarmagic
Wireless (PLL/VCO)	www.national.com/wireless	PowerWise® Design University	www.national.com/training

THE CONTENTS OF THIS DOCUMENT ARE PROVIDED IN CONNECTION WITH NATIONAL SEMICONDUCTOR CORPORATION ("NATIONAL") PRODUCTS. NATIONAL MAKES NO REPRESENTATIONS OR WARRANTIES WITH RESPECT TO THE ACCURACY OR COMPLETENESS OF THE CONTENTS OF THIS PUBLICATION AND RESERVES THE RIGHT TO MAKE CHANGES TO SPECIFICATIONS AND PRODUCT DESCRIPTIONS AT ANY TIME WITHOUT NOTICE. NO LICENSE, WHETHER EXPRESS, IMPLIED, ARISING BY ESTOPPEL OR OTHERWISE, TO ANY INTELLECTUAL PROPERTY RIGHTS IS GRANTED BY THIS DOCUMENT.

TESTING AND OTHER QUALITY CONTROLS ARE USED TO THE EXTENT NATIONAL DEEMS NECESSARY TO SUPPORT NATIONAL'S PRODUCT WARRANTY. EXCEPT WHERE MANDATED BY GOVERNMENT REQUIREMENTS, TESTING OF ALL PARAMETERS OF EACH PRODUCT IS NOT NECESSARILY PERFORMED. NATIONAL ASSUMES NO LIABILITY FOR APPLICATIONS ASSISTANCE OR BUYER PRODUCT DESIGN. BUYERS ARE RESPONSIBLE FOR THEIR PRODUCTS AND APPLICATIONS USING NATIONAL COMPONENTS. PRIOR TO USING OR DISTRIBUTING ANY PRODUCTS THAT INCLUDE NATIONAL COMPONENTS, BUYERS SHOULD PROVIDE ADEQUATE DESIGN, TESTING AND OPERATING SAFEGUARDS.

EXCEPT AS PROVIDED IN NATIONAL'S TERMS AND CONDITIONS OF SALE FOR SUCH PRODUCTS, NATIONAL ASSUMES NO LIABILITY WHATSOEVER, AND NATIONAL DISCLAIMS ANY EXPRESS OR IMPLIED WARRANTY RELATING TO THE SALE AND/OR USE OF NATIONAL PRODUCTS INCLUDING LIABILITY OR WARRANTIES RELATING TO FITNESS FOR A PARTICULAR PURPOSE, MERCHANTABILITY, OR INFRINGEMENT OF ANY PATENT, COPYRIGHT OR OTHER INTELLECTUAL PROPERTY RIGHT.

LIFE SUPPORT POLICY

NATIONAL'S PRODUCTS ARE NOT AUTHORIZED FOR USE AS CRITICAL COMPONENTS IN LIFE SUPPORT DEVICES OR SYSTEMS WITHOUT THE EXPRESS PRIOR WRITTEN APPROVAL OF THE CHIEF EXECUTIVE OFFICER AND GENERAL COUNSEL OF NATIONAL SEMICONDUCTOR CORPORATION. As used herein:

Life support devices or systems are devices which (a) are intended for surgical implant into the body, or (b) support or sustain life and whose failure to perform when properly used in accordance with instructions for use provided in the labeling can be reasonably expected to result in a significant injury to the user. A critical component is any component in a life support device or system whose failure to perform can be reasonably expected to cause the failure of the life support device or system or to affect its safety or effectiveness.

National Semiconductor and the National Semiconductor logo are registered trademarks of National Semiconductor Corporation. All other brand or product names may be trademarks or registered trademarks of their respective holders.

Copyright© 2009 National Semiconductor Corporation

For the most current product information visit us at www.national.com



National Semiconductor Americas Technical Support Center
 Email: support@nsc.com
 Tel: 1-800-272-9959

National Semiconductor Europe Technical Support Center
 Email: europe.support@nsc.com

National Semiconductor Asia Pacific Technical Support Center
 Email: ap.support@nsc.com

National Semiconductor Japan Technical Support Center
 Email: jpn.feedback@nsc.com