

LM3880/LM3880Q Power Sequencer

General Description

The LM3880 Power Sequencer offers the easiest method to control power up and power down of multiple power supplies (switchers or linear regulators). By staggering the startup sequence, it is possible to avoid latch conditions or large in-rush currents that can affect the reliability of the system.

Available in a SOT23-6 package, the Power Sequencer contains a precision enable pin and three open drain output flags. Upon enabling the LM3880 the three output flags will sequentially release, after individual time delays, permitting the connected power supplies to startup. The output flags will follow a reverse sequence during power down to avoid latch conditions.

EPROM capability allows every delay and sequence to be fully adjustable. Contact National Semiconductor if a non-standard configuration is required.

Features

- Easiest method to sequence rails
- Power up and power down control
- Input voltage range of 2.7V to 5.5V
- Small footprint SOT23-6
- Low quiescent current of 25 μ A
- Standard timing options available
- Customization of timing and sequence available through factory programmability
- LM3880Q is AEC-Q100 Grade 1 qualified and is manufactured on an Automotive Grade Flow

Applications

- Multiple supply sequencing
- Microprocessor / Microcontroller sequencing
- FPGA sequencing
- Automotive

Typical Application Circuit

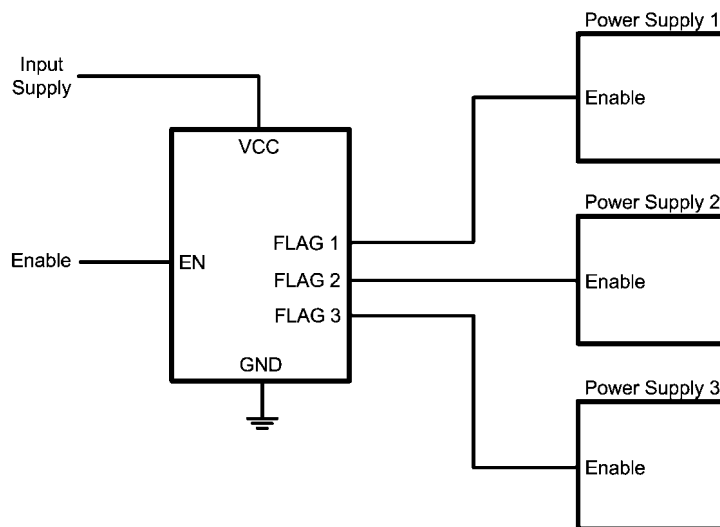

20192601

Connection Diagram

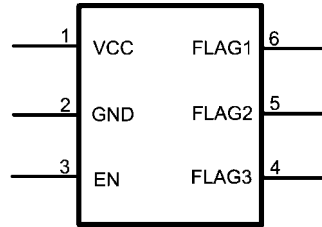

Top View
SOT23-6 Package

20192602

Pin Descriptions

Pin #	Name	Function
1	VCC	Input supply
2	GND	Ground
3	EN	Precision enable pin
4	FLAG3	Open drain output #3
5	FLAG2	Open drain output #2
6	FLAG1	Open drain output #1

Nomenclature

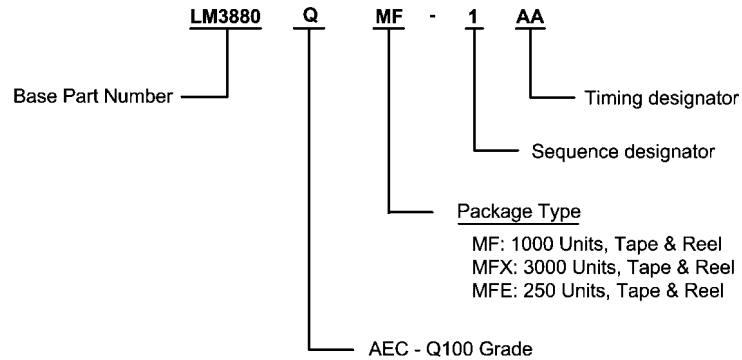

20192603

Sequence Designator Table

Sequence Number	Flag Order	
	Power Up	Power Down
1	1 - 2 - 3	3 - 2 - 1
2	1 - 2 - 3	3 - 1 - 2
3	1 - 2 - 3	2 - 3 - 1
4	1 - 2 - 3	2 - 1 - 3
5	1 - 2 - 3	1 - 3 - 2
6	1 - 2 - 3	1 - 2 - 3

See timing diagrams for more information

Timing Designator Table

Timing Designator	t _{d1}	t _{d2}	t _{d3}	t _{d4}	t _{d5}	t _{d6}
AE	2ms	2ms	2ms	2ms	2ms	2ms
AA	10ms	10ms	10ms	10ms	10ms	10ms
AB	30ms	30ms	30ms	30ms	30ms	30ms
AC	60ms	60ms	60ms	60ms	60ms	60ms
AD	120ms	120ms	120ms	120ms	120ms	120ms

See timing diagrams for more information

LM3880 Ordering Information

Standard Parts for Order*

Order Number	Timer settings	Sequence Order	Supplied As	Package Type	NSC Package Drawing	Package Marking	Feature
	td1 to td6						
LM3880MF-1AE	2ms	1	1k units T&R	SOT23-6	MF06A	F25A	
LM3880MFX-1AE	2ms	1	3k units T&R	SOT23-6	MF06A	F25A	
LM3880MFE-1AE	2ms	1	250 units T&R	SOT23-6	MF06A	F25A	
LM3880MF-1AA	10ms	1	1k units T&R	SOT23-6	MF06A	F20A	
LM3880MFX-1AA	10ms	1	3k units T&R	SOT23-6	MF06A	F20A	
LM3880MFE-1AA	10ms	1	250 units T&R	SOT23-6	MF06A	F20A	
LM3880MF-1AB	30ms	1	1k units T&R	SOT23-6	MF06A	F21A	
LM3880MFX-1AB	30ms	1	3k units T&R	SOT23-6	MF06A	F21A	
LM3880MFE-1AB	30ms	1	250 units T&R	SOT23-6	MF06A	F21A	
LM3880MF-1AC	60ms	1	1k units T&R	SOT23-6	MF06A	F22A	
LM3880MFX-1AC	60ms	1	3k units T&R	SOT23-6	MF06A	F22A	
LM3880MFE-1AC	60ms	1	250 units T&R	SOT23-6	MF06A	F22A	
LM3880MF-1AD	120ms	1	1k units T&R	SOT23-6	MF06A	F23A	
LM3880MFX-1AD	120ms	1	3k units T&R	SOT23-6	MF06A	F23A	
LM3880MFE-1AD	120ms	1	250 units T&R	SOT23-6	MF06A	F23A	
LM3880QMFE-1AE	2ms	1	250 units T&R	SOT23-6	MF06A	F24A	AEC-Q100 Grade 1 qualified. Automotive Grade Production Flow**
LM3880QMF-1AE	2ms	1	1k units T&R	SOT23-6	MF06A	F24A	
LM3880QMF-1AE	2ms	1	3k units T&R	SOT23-6	MF06A	F24A	
LM3880QMFE-1AA	10ms	1	250 units T&R	SOT23-6	MF06A	F27A	
LM3880QMF-1AA	10ms	1	1k units T&R	SOT23-6	MF06A	F27A	
LM3880QMF-1AA	10ms	1	3k units T&R	SOT23-6	MF06A	F27A	
LM3880QMFE-1AB	30ms	1	250 units T&R	SOT23-6	MF06A	F28A	
LM3880QMF-1AB	30ms	1	1k units T&R	SOT23-6	MF06A	F28A	
LM3880QMF-1AB	30ms	1	3k units T&R	SOT23-6	MF06A	F28A	
LM3880QMFE-1AC	60ms	1	250 units T&R	SOT23-6	MF06A	F29A	
LM3880QMF-1AC	60ms	1	1k units T&R	SOT23-6	MF06A	F29A	
LM3880QMF-1AC	60ms	1	3k units T&R	SOT23-6	MF06A	F29A	
LM3880QMFE-1AD	120ms	1	250 units T&R	SOT23-6	MF06A	F30A	
LM3880QMF-1AD	120ms	1	1k units T&R	SOT23-6	MF06A	F30A	
LM3880QMF-1AD	120ms	1	3k units T&R	SOT23-6	MF06A	F30A	

*Non-standard parts are available upon request. Please contact National Semiconductor for more information.

**Automotive Grade (Q) product incorporates enhanced manufacturing and support processes for the automotive market, including defect detection methodologies. Reliability qualification is compliant with the requirements and temperature grades defined in the AEC-Q100 standard. Automotive grade products are identified with the letter Q. For more information go to <http://www.national.com/automotive>.

Absolute Maximum Ratings (Note 1)

If Military/Aerospace specified devices are required, please contact the National Semiconductor Sales Office/Distributors for availability and specifications.

VCC	-0.3V to +6.0V
EN, FLAG1, FLAG2, FLAG3	-0.3V to 6.0V
Max Flag 'ON' Current	50 mA
Storage Temperature Range	-65°C to +150°C
Junction Temperature	150°C
Lead Temperature (Soldering, 5 sec.)	260°C
Minimum ESD Rating	±2 kV

Operating Ratings (Note 1)

VCC to GND	2.7V to 5.5V
EN, FLAG1, FLAG2, FLAG3	-0.3V to $V_{CC} + 0.3V$
Junction Temperature	-40°C to +125°C

Electrical Characteristics

Specifications with standard typeface are for $T_J = 25^\circ\text{C}$, and those in bold face type apply over the full Operating Temperature Range ($T_J = -40^\circ\text{C}$ to $+125^\circ\text{C}$). Minimum and Maximum limits are guaranteed through test, design or statistical correlation. Typical values represent the most likely parametric norm at $T_J = 25^\circ\text{C}$ and are provided for reference purposes only. $V_{CC} = 3.3V$, and limits apply to all timing options, unless otherwise specified.

Symbol	Parameter	Conditions	Min (Note 3)	Typ (Note 4)	Max (Note 3)	Unit
I_Q	Operating Quiescent current			25	80	μA
Open Drain Flags						
I_{FLAG}	FLAGx Leakage Current	$V_{FLAGx} = 3.3V$		1	20	nA
V_{OL}	FLAGx Output Voltage Low	$I_{FLAGx} = 1.2\text{mA}$			0.4	V
Power Up Sequence						
t_{d1}	Timer delay 1 accuracy		-15		15	%
		2ms Timing Option	-20		20	
t_{d2}	Timer delay 2 accuracy		-15		15	%
		2ms Timing Option	-20		20	
t_{d3}	Timer delay 3 accuracy		-15		15	%
		2ms Timing Option	-20		20	
Power Down Sequence						
t_{d4}	Timer delay 4 accuracy		-15		15	%
		2ms Timing Option	-20		20	
t_{d5}	Timer delay 5 accuracy		-15		15	%
		2ms Timing Option	-20		20	
t_{d6}	Timer delay 6 accuracy		-15		15	%
		2ms Timing Option	-20		20	
Timing Delay Error						
$(t_{d(x)} - 400 \mu\text{s}) / t_{d(x+1)}$	Ratio of timing delays	For x = 1 or 4	95		105	%
		For x = 1 or 4, 2ms option	90		110	
$t_{d(x)} / t_{d(x+1)}$	Ratio of timing delays	For x = 2 or 5	95		105	%
		For x = 2 or 5, 2ms option	90		110	
ENABLE Pin						
V_{EN}	EN pin threshold		1.0	1.25	1.4	V
I_{EN}	EN pin pull-up current	$V_{EN} = 0V$		7		μA

Note 1: Absolute Maximum Ratings indicate limits beyond which damage to the device may occur. Operating Ratings indicate conditions for which the device is intended to be functional, but does not guarantee specific performance limits. For guaranteed specifications and conditions, see the Electrical Characteristics.

Note 2: The human body model is a 100 pF capacitor discharged through a 1.5 k Ω resistor into each pin.

Note 3: Limits are 100% production tested at 25°. Limits over the operating temperature range are guaranteed through correlation using Statistical Quality Control (SQC) methods. The limits are used to calculate National's Average Outgoing Quality Level (AOQL).

Note 4: Typical numbers are at 25°C and represent the most likely parametric norm.

Typical Performance Characteristics

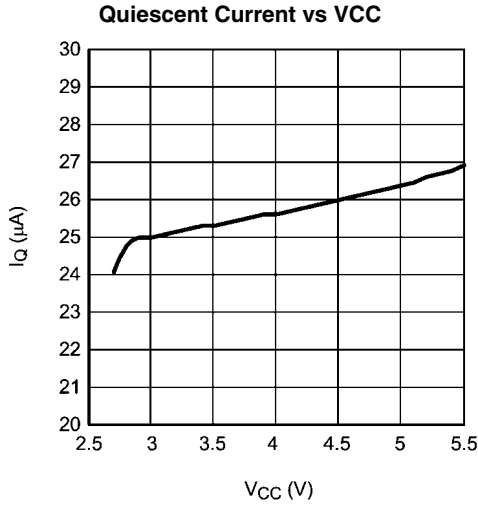

20192604

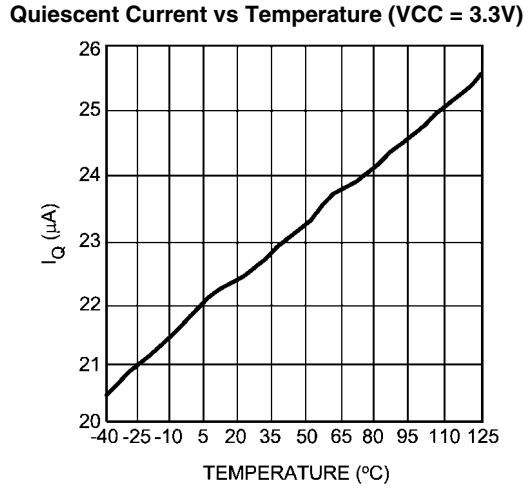

20192605

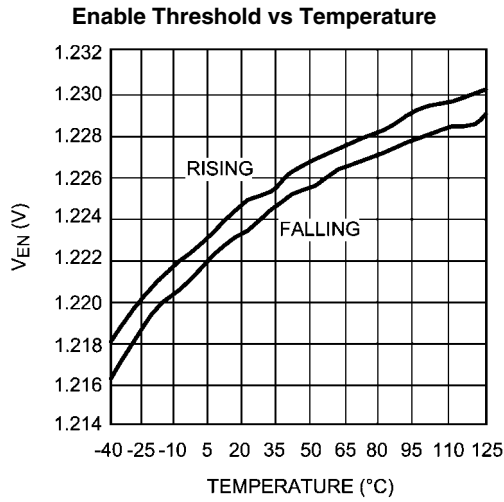

20192606

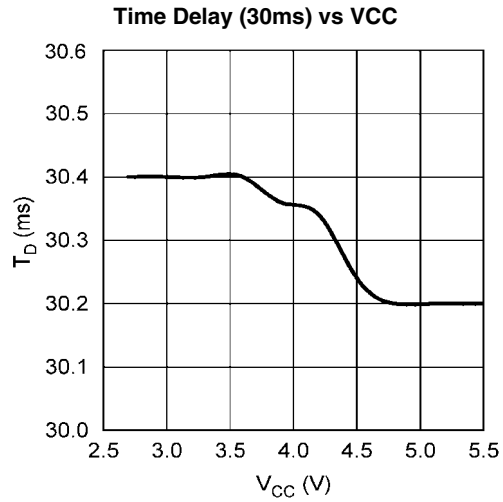

20192607

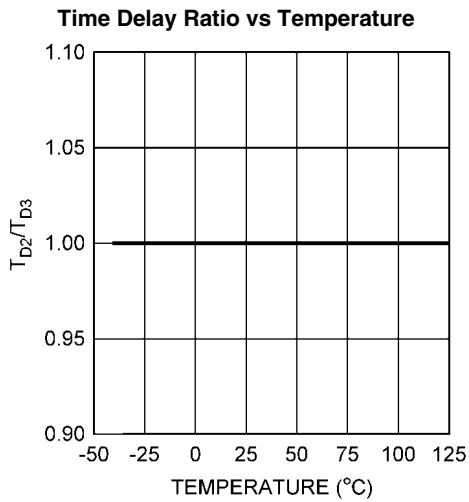

20192608

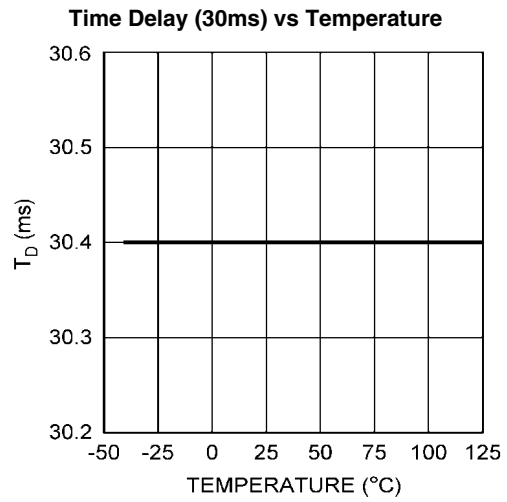

20192609

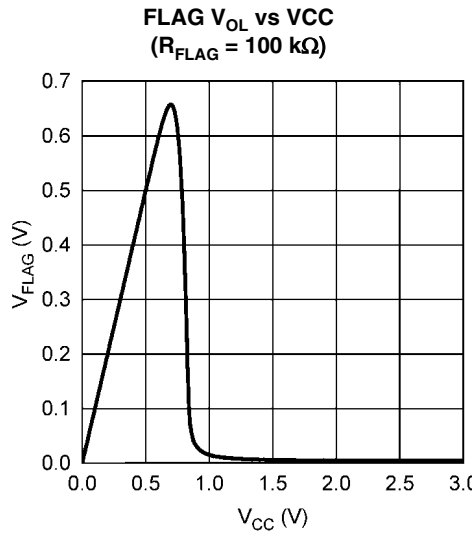

20192610

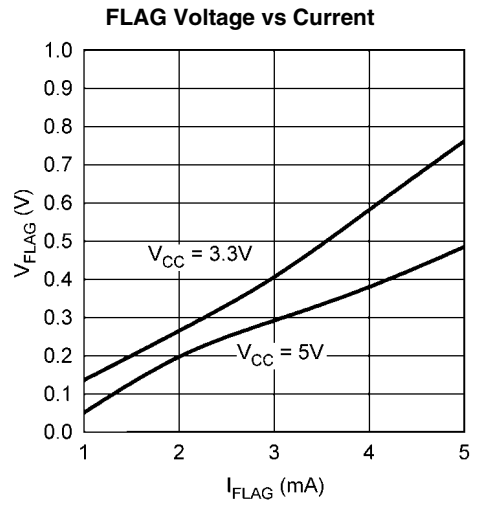

20192611

Block Diagram

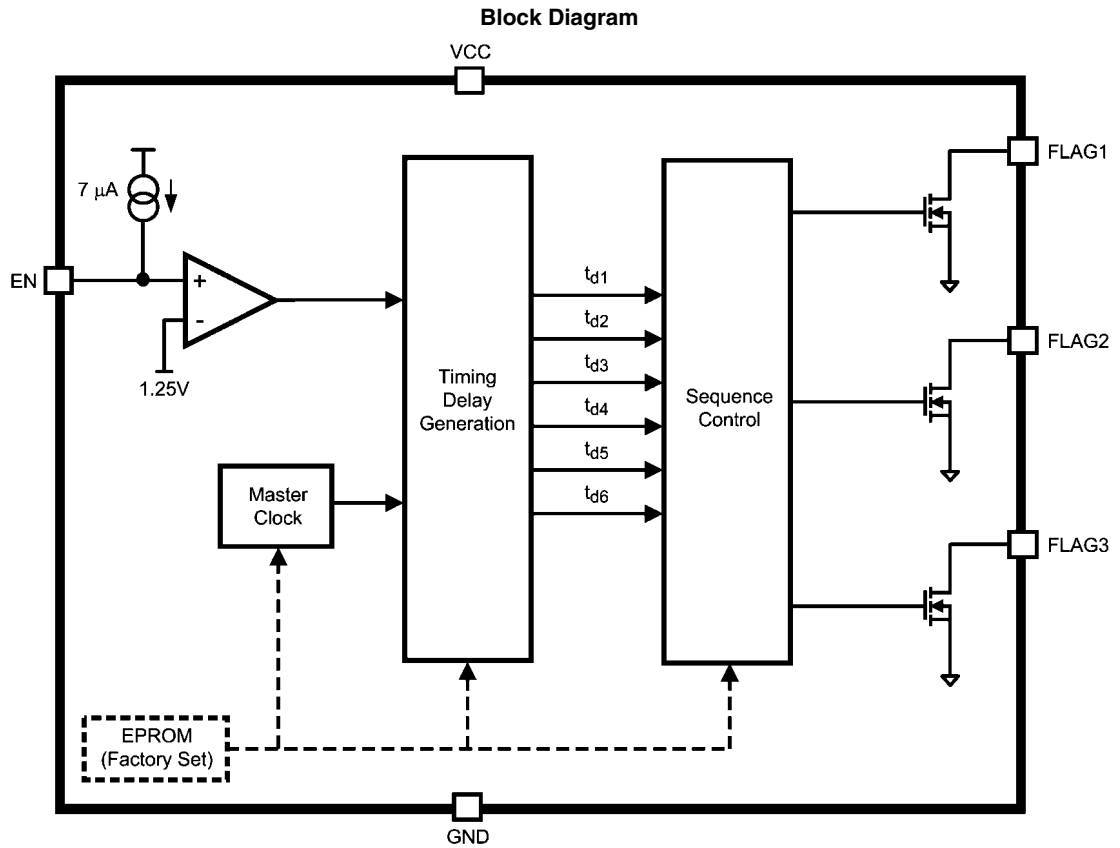

20192612

Timing Diagrams (Sequence 1)

All standard options use this sequence for output flags rise and fall order.

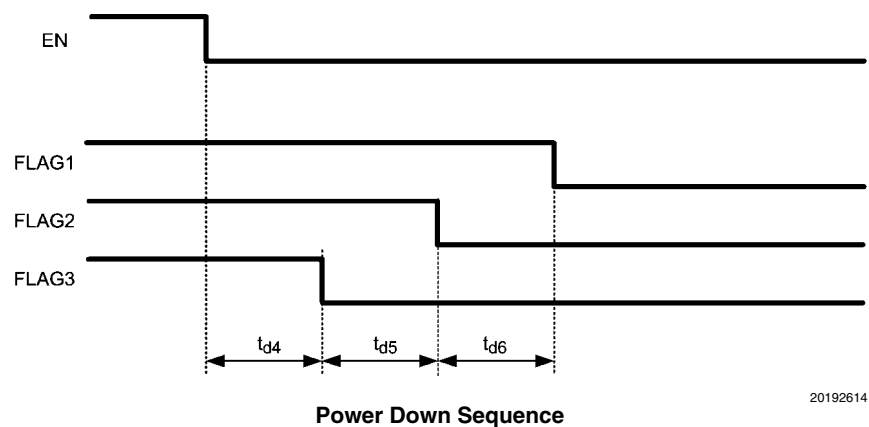
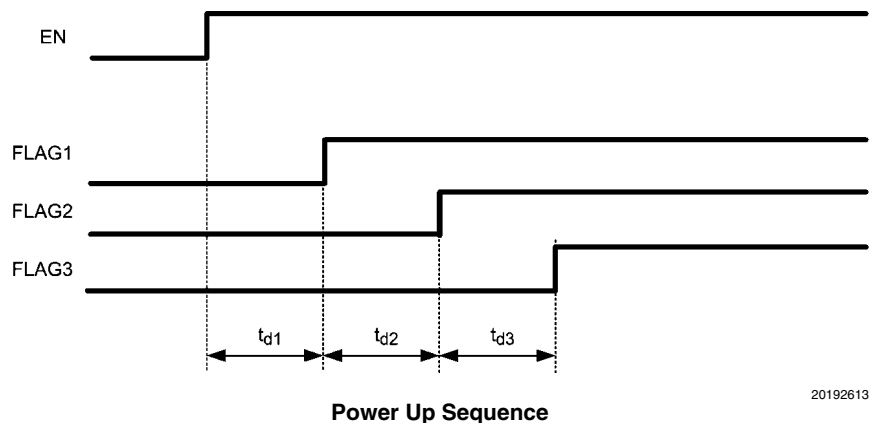

Application Information

OVERVIEW

The LM3880 Power Sequencer provides an easy solution for sequencing multiple rails in a controlled manner. Six independent timers are integrated to control the timing sequence (power up and power down) of three open drain output flags. These flags permit connection to either a shutdown / enable pin of linear regulators and switches to control the power supplies' operation. This allows a complete power system to be designed without worrying about large in-rush currents or latch-up conditions that can occur.

The timing sequence of the LM3880 is controlled entirely by the enable (EN) pin. Upon power up, all the flags are held low until this precision enable is pulled high. After the EN pin is asserted, the power up sequence will commence. An internal counter will delay the first flag (FLAG1) from rising until a fixed time period has expired. Upon the release of the first flag another timer will begin to delay the release of the second flag (FLAG2). This process repeats until all three flags have sequentially been released. The three timers that control the delays are all independent of each other and can be individually programmed if needed. (See custom sequencer section).

The power down sequence is the same as power-up, but in reverse. When EN pin is de-asserted a timer will begin that delays the third flag (FLAG3) from pulling low. The second and first flag will then follow in a sequential manner after their

appropriate delays. The three timers that are used to control the power down scheme can also be individually programmed and are completely independent of the power up timers.

Additional sequence patterns are also available in addition to customizable timers. For more information see the custom sequencer section.

PART OPERATION

The timing sequence of the LM3880 is controlled by the assertion of the enable signal. The enable pin is designed with an internal comparator, referenced to a bandgap voltage (1.25V), to provide a precision threshold. This allows a delayed timing to be externally set using a capacitor or to start the sequencing based on a certain event, such as a line voltage reaching 90% of nominal. For an additional delayed sequence from the rail powering VCC, simply attach a capacitor to the EN pin as shown below.

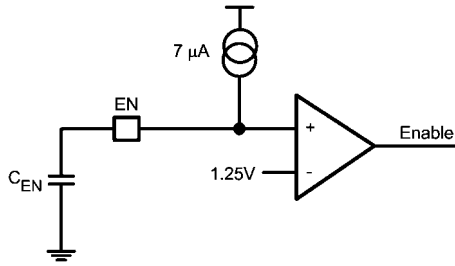

Cap Timing

20192615

Using the internal pull-up current source to charge the external capacitor (C_{EN}) the enable pin delay can be calculated by the equation below:

$$t_{enable_delay} = \frac{1.25V \times C_{EN}}{7 \mu A}$$

A resistor divider can also be used to enable the LM3880 based on a certain voltage threshold. Care needs to be taken when sizing the resistor divider to include the effects of the internal current source.

One of the features of the enable pin is that it provides glitch free operation. The first timer will start counting at a rising threshold, but will always reset if the enable pin is de-asserted before the first output flag is released. This can be shown in the timing diagram below:

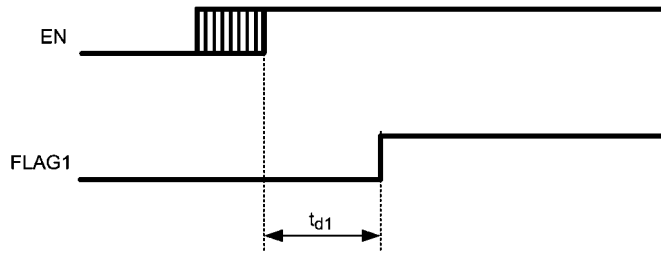

EN Glitch

20192617

If the enable signal remains high for the entire power-up sequence, then the part will operate as shown in the standard timing diagrams. However, if the enable signal is de-asserted before the power-up sequence is completed the part will enter a controlled shutdown. This allows the system to walk through a controlled power cycling, preventing any latch conditions from occurring. This state only occurs if the enable pin is de-asserted after the completion of timer 1, but before the entire power-up sequence is completed.

When this event occurs, the falling edge of enable pin resets the current timer and will allow the remaining power-up cycle to complete before beginning the power down sequence. The power down sequence starts approximately 120ms after the final power-up flag. This allows output voltages in the system to stabilize before everything is shutdown. An example of this operation can be seen below:

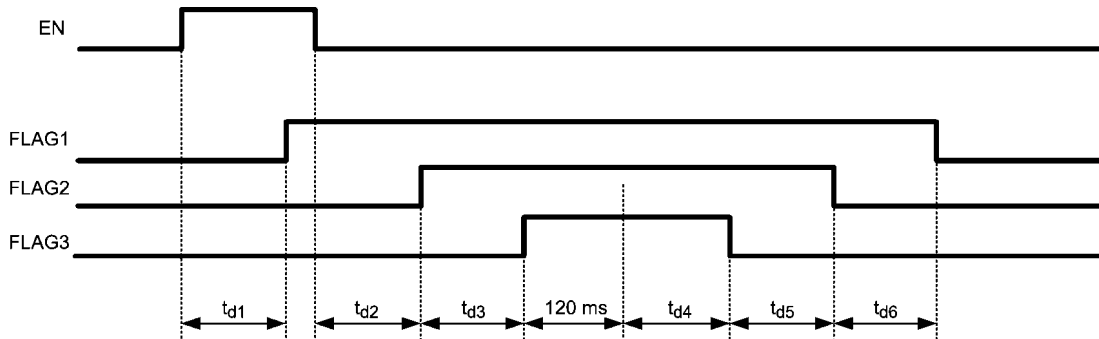

Incomplete Sequence

20192618

All the internal timers are generated by a master clock that has an extremely low tempco. This allows for tight accuracy across temperature and a consistent ratio between the individual timers. There is a slight additional delay of approxi-

mately 400 μs to timers 1 and 4 which is a result of the EPROM refresh. This refresh time is in addition to the programmed delay time and will be almost insignificant to all but the shortest of timer delays.

CUSTOM SEQUENCER

The LM3880 Power Sequencer is based on a CMOS process utilizing an EPROM that has the capability to be custom programmed at the factory. Approximately 500,000,000 different options are available allowing even the most complex system to be simply sequenced. Because of the vast options that are possible, customization is limited to orders of a certain quan-

tity. Please contact National Semiconductor for more information.

The variables that can be programmed include the six delay timers and the reverse sequence order. For the timers, each can be individually selected from one of the timer selector columns in the table shown below. However, all six time delays must be from the same column.

Timer Options 1	Timer Options 2	Timer Options 3	Timer Options 4
0	0	0	0
2	4	6	8
4	8	12	16
6	12	18	24
8	16	24	32
10	20	30	40
12	24	36	48
14	28	42	56
16	32	48	64
18	36	54	72
20	40	60	80
22	44	66	88
24	48	72	96
26	52	78	104
28	56	84	112
30	60	90	120

All times listed are in milliseconds

The sequencing order for power up is always controlled by layout. The flag number translates directly into the sequence order during power up (ie FLAG1 will always be first). However, for some systems a different power down order could be required. To allow flexibility for this aspect in a design, the

Power Sequencer incorporates six different options for controlling the power down sequence. These options can be seen in the timing diagrams on the next page. This ability can be programmed in addition to the custom timers.

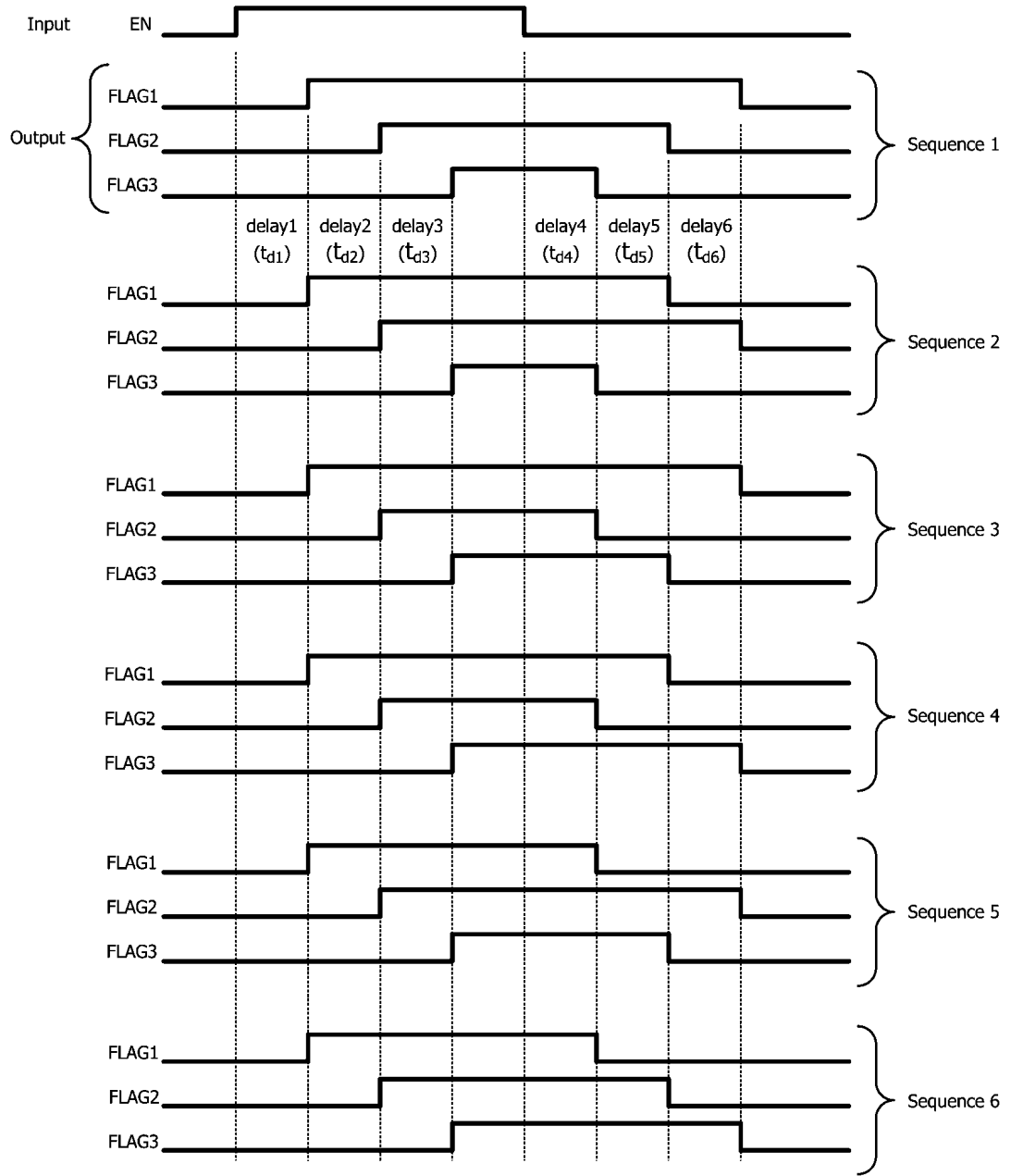

Power Down Sequence Options

20192619

Physical Dimensions inches (millimeters) unless otherwise noted

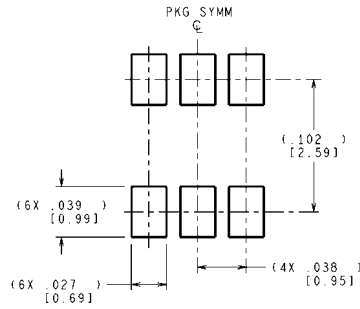
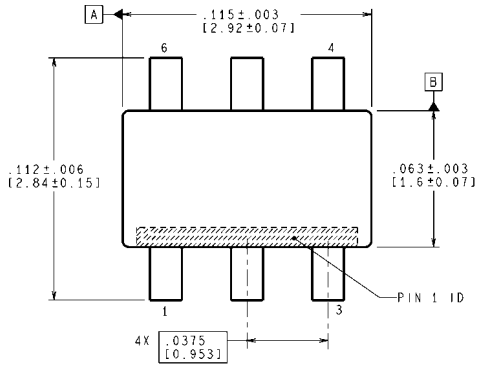

RECOMMENDED LAND PATTERN

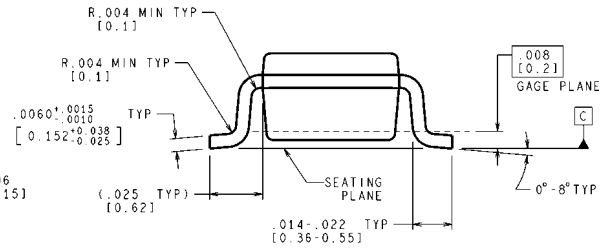
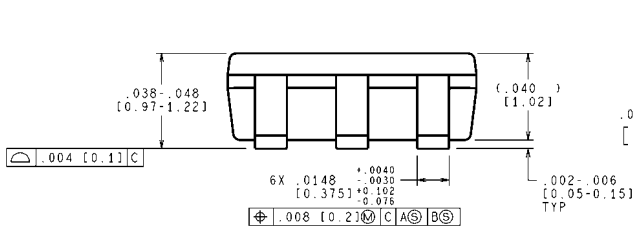

CONTROLLING DIMENSION IS INCH
VALUES IN [] ARE MILLIMETERS
DIMENSIONS IN () FOR REFERENCE ONLY

MF06A (Rev C)

SOT23-6 Package
NS Package Number MF06A

Notes

For more National Semiconductor product information and proven design tools, visit the following Web sites at:

Products		Design Support	
Amplifiers	www.national.com/amplifiers	WEBENCH	www.national.com/webench
Audio	www.national.com/audio	Analog University	www.national.com/AU
Clock Conditioners	www.national.com/timing	App Notes	www.national.com/appnotes
Data Converters	www.national.com/adc	Distributors	www.national.com/contacts
Displays	www.national.com/displays	Green Compliance	www.national.com/quality/green
Ethernet	www.national.com/ethernet	Packaging	www.national.com/packaging
Interface	www.national.com/interface	Quality and Reliability	www.national.com/quality
LVDS	www.national.com/lvds	Reference Designs	www.national.com/refdesigns
Power Management	www.national.com/power	Feedback	www.national.com/feedback
Switching Regulators	www.national.com/switchers		
LDOs	www.national.com/lido		
LED Lighting	www.national.com/led		
PowerWise	www.national.com/powerwise		
Serial Digital Interface (SDI)	www.national.com/sdi		
Temperature Sensors	www.national.com/tempsensors		
Wireless (PLL/VCO)	www.national.com/wireless		

THE CONTENTS OF THIS DOCUMENT ARE PROVIDED IN CONNECTION WITH NATIONAL SEMICONDUCTOR CORPORATION ("NATIONAL") PRODUCTS. NATIONAL MAKES NO REPRESENTATIONS OR WARRANTIES WITH RESPECT TO THE ACCURACY OR COMPLETENESS OF THE CONTENTS OF THIS PUBLICATION AND RESERVES THE RIGHT TO MAKE CHANGES TO SPECIFICATIONS AND PRODUCT DESCRIPTIONS AT ANY TIME WITHOUT NOTICE. NO LICENSE, WHETHER EXPRESS, IMPLIED, ARISING BY ESTOPPEL OR OTHERWISE, TO ANY INTELLECTUAL PROPERTY RIGHTS IS GRANTED BY THIS DOCUMENT.

TESTING AND OTHER QUALITY CONTROLS ARE USED TO THE EXTENT NATIONAL DEEMS NECESSARY TO SUPPORT NATIONAL'S PRODUCT WARRANTY. EXCEPT WHERE MANDATED BY GOVERNMENT REQUIREMENTS, TESTING OF ALL PARAMETERS OF EACH PRODUCT IS NOT NECESSARILY PERFORMED. NATIONAL ASSUMES NO LIABILITY FOR APPLICATIONS ASSISTANCE OR BUYER PRODUCT DESIGN. BUYERS ARE RESPONSIBLE FOR THEIR PRODUCTS AND APPLICATIONS USING NATIONAL COMPONENTS. PRIOR TO USING OR DISTRIBUTING ANY PRODUCTS THAT INCLUDE NATIONAL COMPONENTS, BUYERS SHOULD PROVIDE ADEQUATE DESIGN, TESTING AND OPERATING SAFEGUARDS.

EXCEPT AS PROVIDED IN NATIONAL'S TERMS AND CONDITIONS OF SALE FOR SUCH PRODUCTS, NATIONAL ASSUMES NO LIABILITY WHATSOEVER, AND NATIONAL DISCLAIMS ANY EXPRESS OR IMPLIED WARRANTY RELATING TO THE SALE AND/OR USE OF NATIONAL PRODUCTS INCLUDING LIABILITY OR WARRANTIES RELATING TO FITNESS FOR A PARTICULAR PURPOSE, MERCHANTABILITY, OR INFRINGEMENT OF ANY PATENT, COPYRIGHT OR OTHER INTELLECTUAL PROPERTY RIGHT.

LIFE SUPPORT POLICY

NATIONAL'S PRODUCTS ARE NOT AUTHORIZED FOR USE AS CRITICAL COMPONENTS IN LIFE SUPPORT DEVICES OR SYSTEMS WITHOUT THE EXPRESS PRIOR WRITTEN APPROVAL OF THE CHIEF EXECUTIVE OFFICER AND GENERAL COUNSEL OF NATIONAL SEMICONDUCTOR CORPORATION. As used herein:

Life support devices or systems are devices which (a) are intended for surgical implant into the body, or (b) support or sustain life and whose failure to perform when properly used in accordance with instructions for use provided in the labeling can be reasonably expected to result in a significant injury to the user. A critical component is any component in a life support device or system whose failure to perform can be reasonably expected to cause the failure of the life support device or system or to affect its safety or effectiveness.

National Semiconductor and the National Semiconductor logo are registered trademarks of National Semiconductor Corporation. All other brand or product names may be trademarks or registered trademarks of their respective holders.

Copyright© 2008 National Semiconductor Corporation

For the most current product information visit us at www.national.com



National Semiconductor Americas Technical Support Center
Email: support@nsc.com
Tel: 1-800-272-9959

National Semiconductor Europe Technical Support Center
Email: europe.support@nsc.com
German Tel: +49 (0) 180 5010 771
English Tel: +44 (0) 870 850 4288

National Semiconductor Asia Pacific Technical Support Center
Email: ap.support@nsc.com

National Semiconductor Japan Technical Support Center
Email: jpn.feedback@nsc.com