



L6717

High-efficiency hybrid AM2r2 controller with I²C interface and embedded drivers

Features

- Hybrid controller for both PVI and SVI CPUs
- Dual controller with 2 embedded high current drivers + 2 PWM for external driver for CPU CORE and 1 embedded high current driver for CPU NB
- Dynamic phase management (DPM)
- I²C interface to control offset, switching frequency and power management options
- Dual-edge asynchronous architecture with LTB technology[®]
- PSI management to increase efficiency in light-load conditions
- Dual overcurrent protection: Total and per-phase
- Accurate voltage positioning
- Dual remote sense
- Feedback disconnection protection
- Programmable OV protection
- Oscillator internally fixed at 200 kHz externally adjustable
- LSLess startup to manage pre-biased output
- VFQFPN48 Package

Applications

- Hybrid high-current VRM / VRD for desktop / Server / Workstation / IPC CPUs supporting PVI and SVI interface
- High-density DC / DC converters

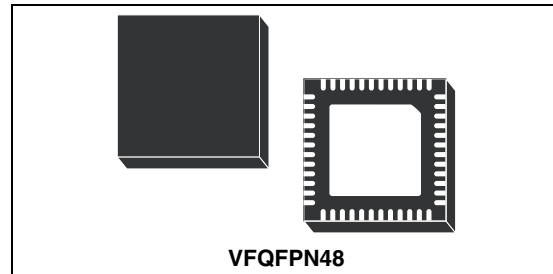

Description

L6717 is a hybrid CPU power supply controller embedding 2 high-current drivers for the CORE section and 1 driver for the NB section - requiring up to 2 external drivers when the CORE section works at 4 phase to optimize the application over-all cost.

I²C interface allows to manage offset both CORE and NB sections, switching frequency and dynamic phase management saving in component count, space and power consumption.

Dynamic phase management automatically adjusts phase-count according to CPU load optimizing the system efficiency under all load conditions.

The dual-edge asynchronous architecture is optimized by LTB technology[®] allowing fast load-transient response minimizing the output capacitor and reducing the total BOM cost.

Fast protection against load over current is provided for both the sections. Feedback disconnection protection prevents from damaging the load in case of disconnections in the system board.

L6717 is available in VFQFPN48 package.

Table 1. Device summary

Order codes	Package	Packing
L6717	VFQFPN48	Tray
L6717TR		Tape and reel

Contents

1	Typical application circuit and block diagram	4
1.1	Application circuit	4
1.2	Block diagram	7
2	Pins description and connection diagrams	8
2.1	Pin descriptions	8
2.2	Thermal data	13
3	Electrical specifications	14
3.1	Absolute maximum ratings	14
3.2	Electrical characteristics	15
4	Device description and operation	18
5	Hybrid CPU support and CPU_TYPE detection	19
5.1	PVI - parallel interface	19
5.2	PVI start-up	19
5.3	SVI - serial interface	21
5.4	SVI start-up	21
5.4.1	Set VID command	21
5.4.2	PWROK de-assertion	24
5.4.3	PSI_L and efficiency optimization at light-load	24
5.4.4	HiZ management	25
5.4.5	Hardware jumper override - V_FIX	25
6	Power manager I2C	26
6.1	Power manager commands	26
6.1.1	Overspeeding command (OVRSPD)	29
6.1.2	Overvoltage threshold adjustment (OV_SET)	30
6.1.3	Switching frequency adjustment (FSW_ADJ)	30
6.1.4	Droop function adjustment (DRP_ADJ)	31
6.1.5	Power management flags	31
6.2	Dynamic phase management (DPM)	32

7	Output voltage positioning	34
	7.1 CORE section - phase # programming	35
	7.2 CORE section - current reading and current sharing loop	35
	7.3 CORE section - defining load-line	36
	7.4 CORE section - analog offset (Optional - I2CDIS = 3.3 V)	37
	7.5 NB section - current reading	37
	7.6 NB section - defining load-line	37
	7.7 On-the-fly VID transitions	38
	7.8 Soft-start	40
	7.8.1 LS-Less Start-up	40
8	Output voltage monitoring and protections	41
	8.1 Programmable overvoltage (I2DIS = 3.3 V)	41
	8.2 Feedback disconnection	42
	8.3 PWRGOOD	43
	8.4 Overcurrent	43
	8.4.1 CORE section	43
	8.4.2 NB section	45
9	Main oscillator	46
10	High current embedded drivers	47
	10.1 Boot capacitor design	47
	10.2 Power dissipation	48
11	System control loop compensation	49
	11.1 Compensation network guidelines	50
12	LTB Technology[®]	51
13	Layout guidelines	52
	13.1 Power components and connections	52
	13.2 Small signal components and connections	53
14	VFQFPN48 mechanical data and package dimensions	54
15	Revision history	55

1 Typical application circuit and block diagram

1.1 Application circuit

Figure 1. Typical 4+1 application circuit

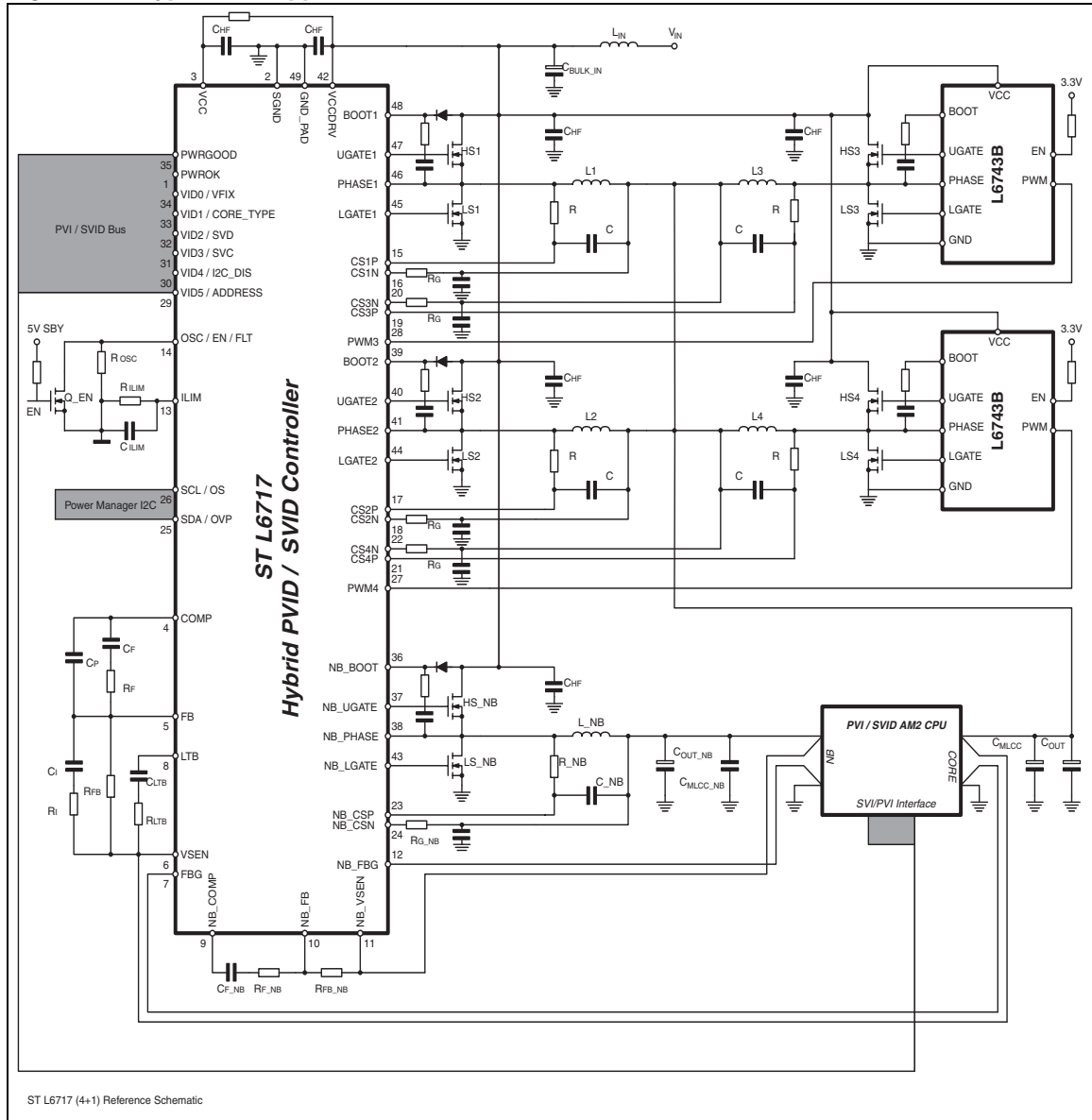

Figure 2. Typical 3+1 application circuit

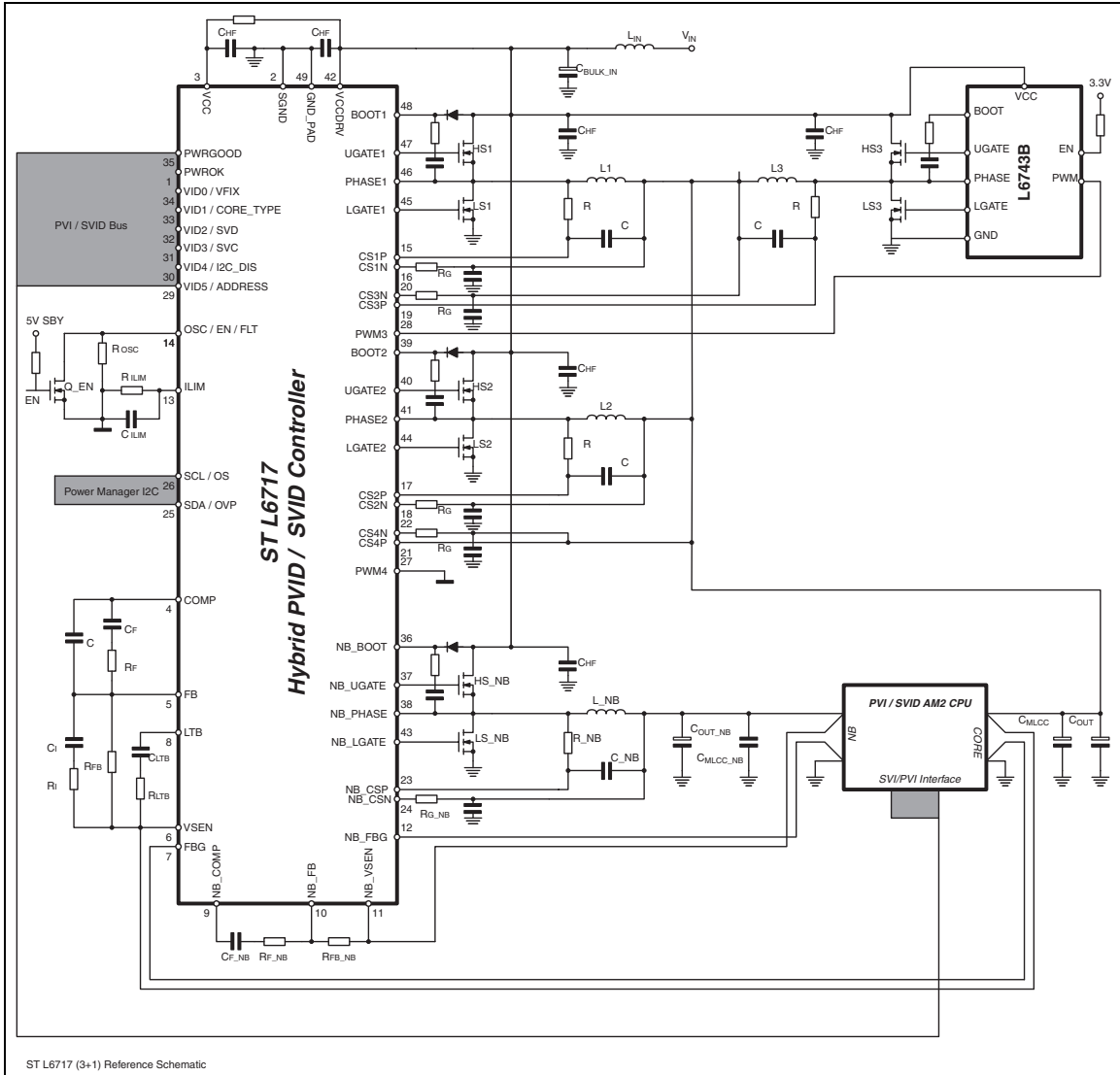
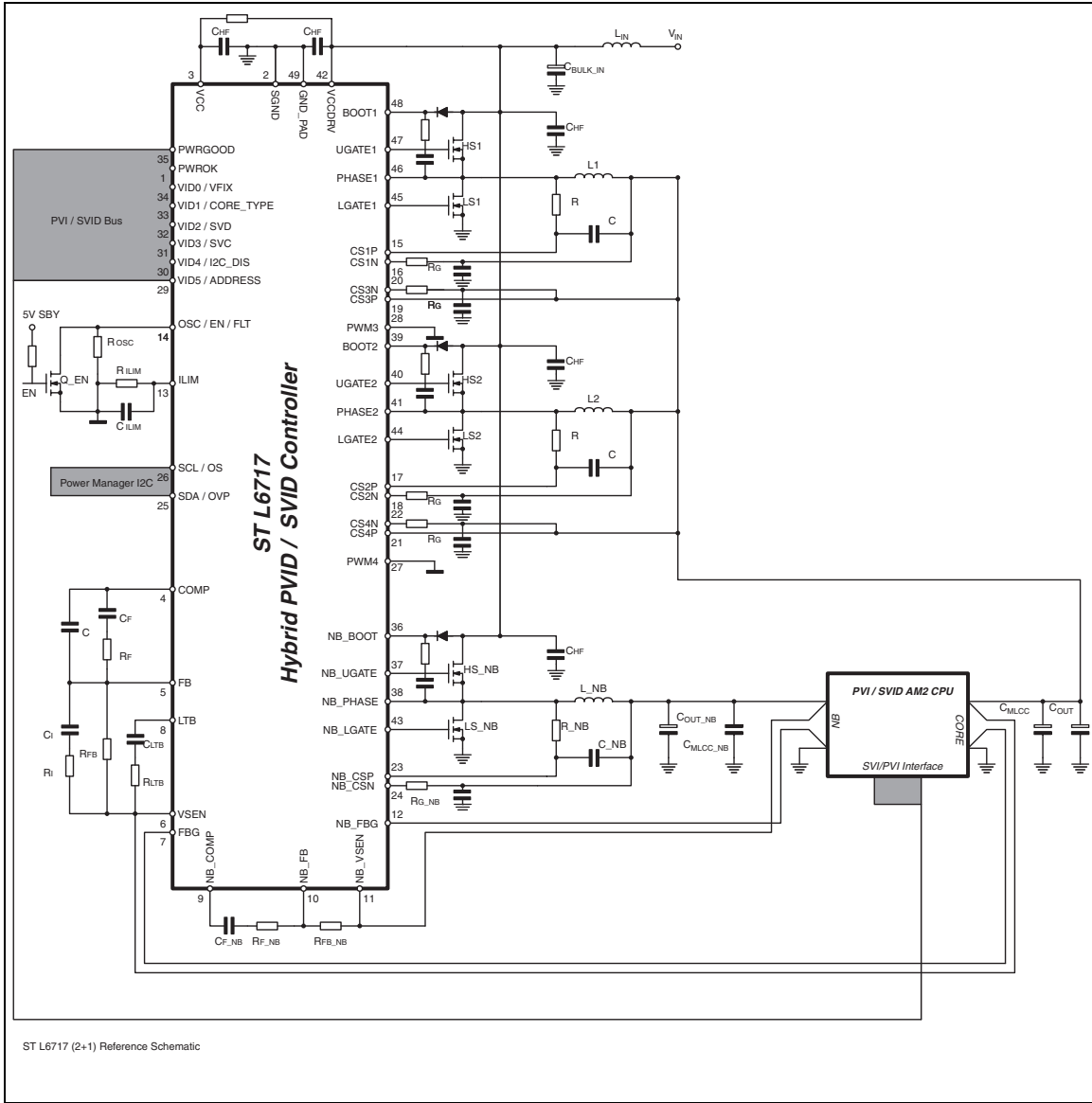
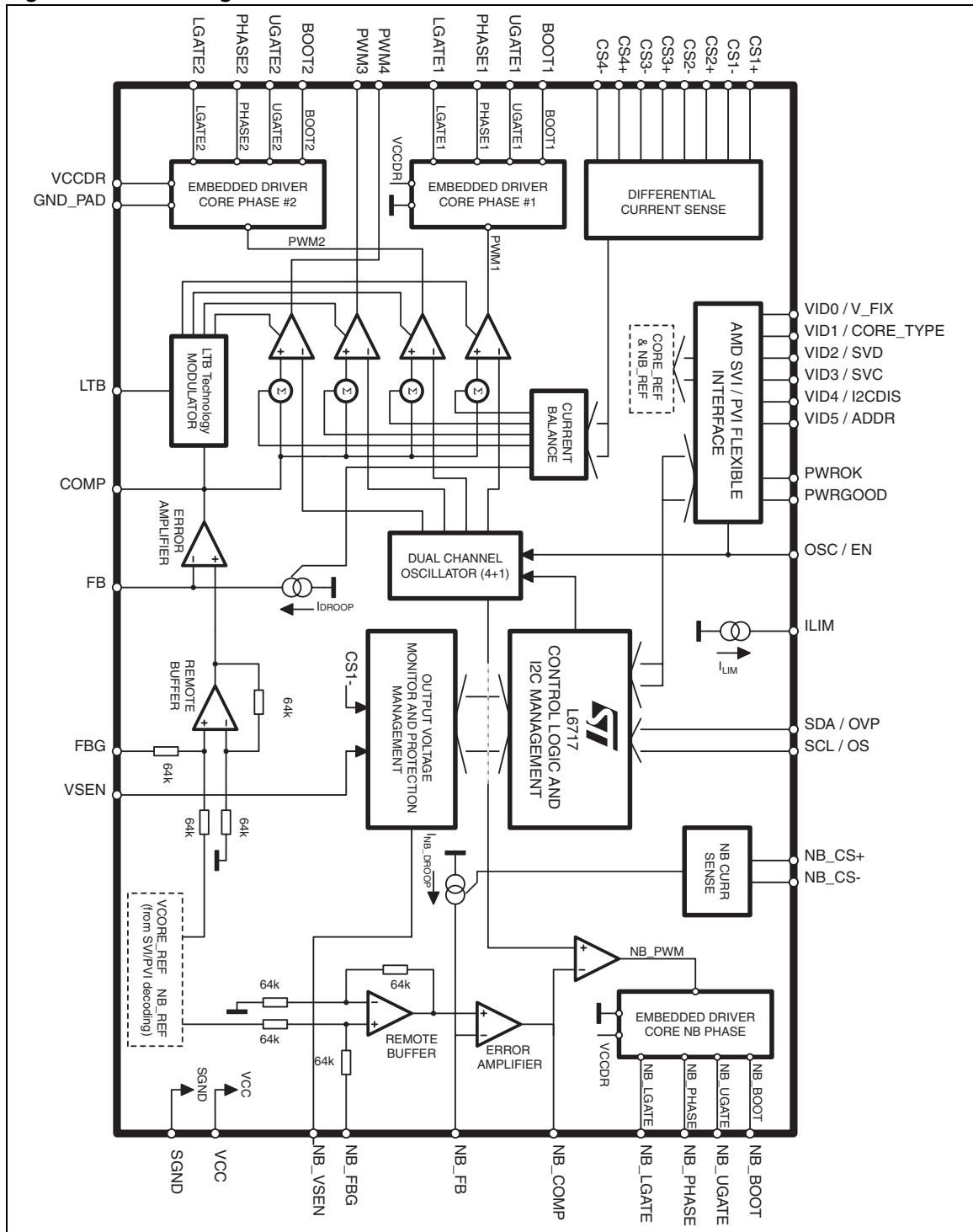

Figure 3. Typical 2+1 application circuit



1.2 Block diagram

Figure 4. Block diagram



2 Pins description and connection diagrams

Figure 5. Pins connection (Top view)

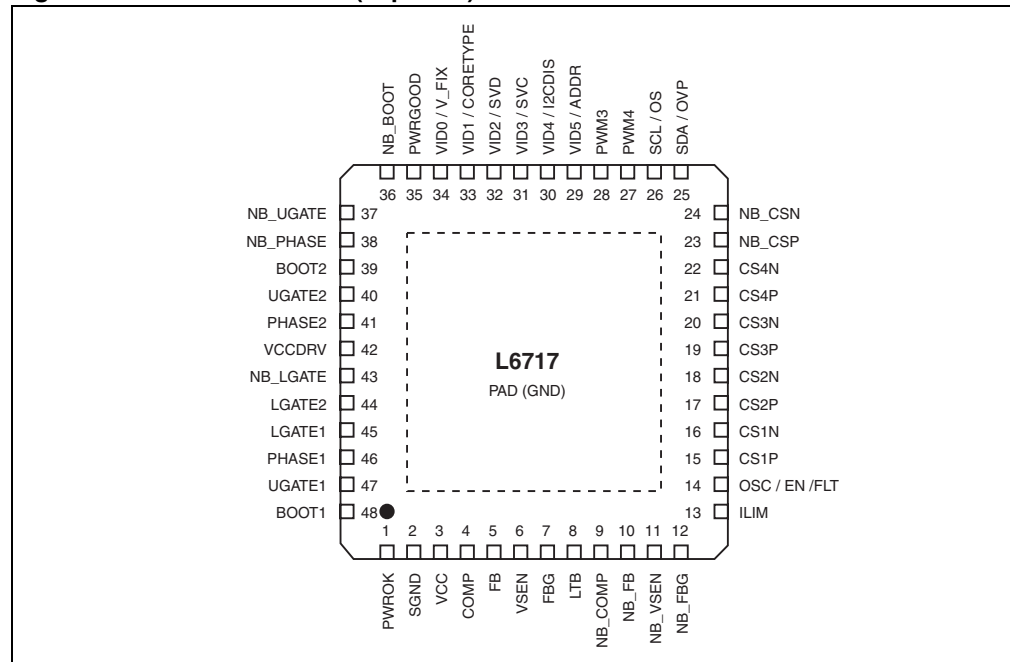

2.1 Pin descriptions

Table 2. Pin description

Pin#	Name	Function
1	PWROK	System-wide Power Good input (Ignored in PVI mode). Internally pulled-low by 10 μ A. When low, the device will decode the two SVI bits SVC and SVD to determine the <i>Pre-PWROK Metal VID</i> . When high, the device will actively run the SVI protocol. <i>Pre-PWROK Metal VID</i> are latched after EN is asserted and re-used in case of PWROK de-assertion. Latch is reset by VCC or EN cycle.
2	SGND	Device signal ground. All the internal references are referred to this pin. Connect to the PCB signal ground.
3	VCC	Device power supply. Operative voltage is 12 \pm 15%. Filter with 1 μ F MLCC to SGND. Do not connect VCC to any voltage greater than VCCDR.
4	CORE section COMP	CORE error amplifier output. Connect with an R _F - C _F to FB. The CORE section and/or the device cannot be disabled by grounding this pin.

Table 2. Pin description (continued)

Pin#	Name	Function
5	FB	CORE error amplifier inverting input. Connect with a resistor R_{FB} to VSEN and with an $R_F - C_F$ to COMP. Droop current for voltage positioning is sourced from this pin.
6	VSEN	CORE output voltage monitor. It manages OVP and UVP protections and PWRGOOD. Connect to the positive side of the load for remote sensing. See Section 8 for details.
7	FBG	CORE remote ground sense. Connect to the negative side of the load for remote sensing. See Section 11 for proper layout of this connection.
8	LTB	LTB Technology® input pin. Connect through an $R_{LTB} - C_{LTB}$ network to the regulated voltage (CORE section) to detect load transient. See Section 12 for details.
9	NB_COMP	NB error amplifier output. Connect with an $R_{F_NB} - C_{F_NB}$ to NB_FB. The NB section and/or the device cannot be disabled by grounding this pin.
10	NB_FB	NB error amplifier inverting input. Connect with a resistor R_{FB_NB} to NB_VSEN and with an $R_{F_NB} - C_{F_NB}$ to NB_COMP. Droop current for voltage positioning is sourced from this pin.
11	NB_VSEN	NB output voltage monitor. It manages OVP and UVP protections and PWRGOOD. Connect to the positive side of the NB load to perform remote sensing. See Section 11 for proper layout of this connection.
12	NB_FBG	NB remote ground sense. Connect to the negative side of the load to perform remote sense. See Section 11 for proper layout of this connection.
13	ILIM	CORE over current pin. A current $I_{LIM} = DCR/R_G * I_{OUT}$ proportional to the current delivered by the CORE Section is sourced from this pin. The OC threshold is programmed by connecting a resistor R_{ILIM} to SGND. When the generated voltage crosses the OC_TOT threshold ($V_{OC_TOT} = 2.5V$ Typ) the device latches with all MOSFETs OFF (to recover, cycle VCC or the EN pin). This pin is monitored for dynamic phase management. Filter with proper capacitor to provide OC masking time; do not exceed 30µsec. See Section 8.4.1 for details.
14	OSC / EN / FLT	OSC: It allows programming the switching frequency F_{SW} of both sections. Switching frequency can be increased according to the resistor R_{OSC} connected to SGND with a gain of 9.1kHz/µA (see Section 9 for details). If floating, the switching frequency is 200kHz per phase. EN: Pull-low (tie to GND) to disable the device. When set free, the device immediately checks for the VID1 status to determine the SVI / PVI protocol to be adopted and configures itself accordingly. FLT: The pin is internally forced high (3.3V) in case of an OV / UV fault. To recover from this condition, cycle VCC or the EN pin. To enable/disable the IC drive OSC/EN/FAUT pin by an open drain circuit.

Table 2. Pin description (continued)

Pin#	Name	Function
15	CS1P	Channel 1 current sense positive input. Connect through an R-C filter to the phase-side of the channel 1 inductor. See Section 11 for proper layout of this connection.
16	CS1N	Channel 1 current sense negative input. Connect through a R_G resistor to the output-side of the channel inductor. Filter the Vout-side of R_G resistor with 100nF to GND. See Section 11 for proper layout of this connection.
17	CS2P	Channel 2 current sense positive input. Connect through an R-C filter to the phase-side of the channel 2 inductor. See Section 11 for proper layout of this connection.
18	CS2N	Channel 2 current sense negative input. Connect through a R_G resistor to the output-side of the channel inductor. Filter the Vout-side of R_G resistor with 100nF to GND. See Section 11 for proper layout of this connection.
19	CS3P	Channel 3 current sense positive input. Connect through an R-C filter to the phase-side of the channel 3 inductor. When working at 2 phase, directly connect to V_{out_CORE-} . See Section 11 for proper layout of this connection.
20	CS3N	Channel 3 current sense negative input. Connect through a R_G resistor to the output-side of the channel inductor. When working at 2 phase, connect through R_G to CS3+. Filter the Vout-side of R_G resistor with 100nF to GND. See Section 11 for proper layout of this connection.
21	CS4P	Channel 4 current sense positive input. Connect through an R-C filter to the phase-side of the channel 4 inductor. When working at 2 or 3 phase, directly connect to V_{out_CORE-} . See Section 11 for proper layout of this connection.
22	CS4N	Channel 4 current sense negative input. Connect through a R_G resistor to the output-side of the channel inductor. When working at 2 or 3 phase, connect through R_G to CS4+. Filter the Vout-side of R_G resistor with 100nF to GND. See Section 11 for proper layout of this connection.
23	NB_CSP	NB channel current sense positive input. Connect through an R-C filter to the phase-side of the NB channel inductor. See Section 11 for proper layout of this connection.
24	NB_CSN	NB channel current sense negative input. Connect through a R_G resistor to the output-side of the channel inductor. Filter the Vout-side of R_G resistor with 100nF to GND. See Section 11 for proper layout of this connection.

Table 2. Pin description (continued)

Pin#	Name	Function
25	Power manager I ² C	<p>SDA - power manager I²C data. When power manager I²C is enabled, this is the data connection. See Section 6 for details.</p> <p>OVP - over voltage setting. When power manager I²C is disabled (VID4 / I2CDIS to 3.3V) the pin is used to set the OVP protection for CORE and NB sections. Define the OVP threshold by connecting the pin to the center tap of a voltage divider from 3V3 to SGND. See Section 8.1 for details.</p>
26		<p>SCL - power manager I²C clock. When power manager I²C is enabled, this is the clock connection. See Section 6 for details.</p> <p>OS - CORE section offset. When power manager I²C is disabled (VID4 / I2CDIS to 3.3V) this pin is internally set to 1.24V(2.0V): connecting a R_{OS} resistor to GND (3.3V) allows setting a current that is mirrored into FB pin in order to program a positive (negative) offset according to the selected R_{FB}. Short to GND to disable the function. See Section 7.4 for details.</p>
27, 28	PWM4, PWM3	<p>PWM output for external drivers. Connect to external drivers PWM inputs. The device is able to manage HiZ status by setting the pins floating. By shorting to GND PWM4 or PWM3 and PWM4, it is possible to program the CORE section to work at 3 or 2 phase respectively. See Section 5.4.4 for details about HiZ management.</p>
29	SVI / PVI interface	<p>VID5 / ADDR Voltage identification pin - I²C address pin. Internally pulled-low by 10μA, it programs the output voltage in PVI mode. In SVI mode, the pin is monitored on the EN pin rising-edge to modify the I²C address. See Section 5 for details.</p>
30		<p>VID4 / I2CDIS Voltage identification pin - I²C disable pin. Internally pulled-low by 10μA, it programs the output voltage in PVI mode. In SVI mode, the pin is monitored on the EN pin rising-edge to enable/disable the I²C. See Section 5 for details.</p>
31		<p>VID3 / SVC Voltage IDentification Pin - SVI clock pin. Internally pulled-low by 10μA, it programs the output voltage in both SVI and PVI modes. In SVI mode, the 10μA pull down is disabled. See Section 5 for details.</p>
32		<p>VID2 / SVD Voltage identification pins - SVI data pin. Internally pulled-low by 10μA, it programs the output voltage in both SVI and PVI modes. In SVI mode, the 10μA pull down is disabled. See Section 5 for details.</p>
33	SVI / PVI interface	<p>VID1 / CORETYPE Voltage identification pin. Internally pulled-low by 10μA, it programs the output voltage in PVI mode. The pin is monitored on the EN pin rising-edge to define the operative mode of the controller (SVI or PVI). See Section 5 for details.</p>
34		<p>VID0 / VFIX Voltage identification pin. Internally pulled-low by 10μA, it programs the output voltage in PVI mode. If the pin is pulled to 3.3V, the device enters V_FIX mode and SVI commands are ignored. See Section 5 for details.</p>

Table 2. Pin description (continued)

Pin#	Name	Function
35	PWRGOOD	VCORE and NB Power Good. It is an open-drain output set free after SS as long as both the voltage planes are within specifications. Pull-up to 3.3V (typ) or lower, if not used it can be left floating. When in PVI mode, it monitors the CORE section only.
36	Embedded drivers	NB_BOOT NB section high-side driver supply. This pin supplies the high-side floating driver. Connect through C _{BOOT} capacitor to the NB_PHASE pin. See Section 10 for guidance in designing the capacitor value.
37		NB_UGATE NB section high-side driver output. Connect to NB section high-side MOSFET gate. A small series resistor may help in reducing NB_PHASE pin negative spike as well as cooling the device.
38		NB_PHASE NB section high-side driver return path. Connect to the NB section high-side MOSFET source. This pin is also monitored for the adaptive dead-time management.
39		BOOT2 CORE section, phase 2 high-side driver supply. This pin supplies the High-Side floating driver. Connect through C _{BOOT} capacitor to the PHASE2 pin. See Section 10 for guidance in designing the capacitor value.
40		UGATE2 High-side driver output. Connect to Phase2 high-side MOSFET gate. A small series resistor may help in reducing PHASE2 pin negative spike as well as cooling the device.
41		PHASE2 CORE section, phase 2 high-side driver return path. Connect to the Phase2 high-side MOSFET source. This pin is also monitored for the adaptive dead-time management.
42	VCCDRV	Supply voltage for low-side embedded drivers. Operative voltage is flexible from 5V ±5% to 12 ±15%. Filter with 1µF MLCC to GND. Do not connect VCC to any voltage greater than VCCDR.
43 to 45	Embedded drivers	NB_LGATE, LGATE2, LGATE1 Low-side driver output. Connect directly to the low-side MOSFET gate of the related section. A small series resistor can be useful to reduce dissipated power especially in high frequency applications.
46		PHASE1 CORE section, phase 1 high-side driver return path. Connect to the phase1 high-side MOSFET source. This pin is also monitored for the adaptive dead-time management.
47		UGATE1 High-side driver output. Connect to phase1 high-side MOSFET gate. A small series resistor may help in reducing PHASE1 pin negative spike as well as cooling the device.
48		BOOT1 CORE section, phase 1 high-side driver supply. This pin supplies the high-side floating driver. Connect through C _{BOOT} capacitor to the PHASE1 pin. See Section 10 for guidance in designing the capacitor value.
Thermal PAD	GND	All internal references, logic, and the Silicon substrate are referenced to this pin. Connect to the PCB GND ground plane by multiple vias to improve heat dissipation.

2.2 Thermal data

Table 3. Thermal data

Symbol	Parameter	Value	Unit
R_{THJA}	Thermal resistance junction to ambient (Device soldered on 2s2p PC board)	40	°C/W
R_{THJC}	Thermal resistance junction to case	1	°C/W
T_{MAX}	Maximum junction temperature	150	°C
T_{STG}	Storage temperature range	-40 to 150	°C
T_J	Junction temperature range	0 to 125	°C

3 Electrical specifications

3.1 Absolute maximum ratings

Table 4. Absolute maximum ratings

Symbol	Parameter	Value	Unit
V_{CC}, V_{CCDRV}	to GND	-0.3 to 15	V
$V_{BOOTx},$ V_{UGATEx}	to GND to PHASEx	41 15	V
V_{PHASEx}	to GND to GND, $t < 200\text{nsec.}$	-8 to 26 30	V
V_{LGATEx}	to GND to GND, $t < 100\text{nsec.}$	-0.3 to $V_{CCDRV} + 0.3$ -3	V
	All other pins to GND	-0.3 to 3.6	V
	Maximum withstanding voltage range test condition: CDF-AEC-Q100-002- "human body model" acceptance "normal performance"	± 1750	V

3.2 Electrical characteristics

$V_{CC}=12\text{ V}\pm 15\%$, $T_J = 0\text{ }^\circ\text{C}$ to $70\text{ }^\circ\text{C}$ unless otherwise specified.

Table 5. Electrical characteristics

Symbol	Parameter	Test conditions	Min.	Typ.	Max.	Unit
Supply current and power-on						
I_{CC}	VCC supply current	OSC = GND		15		mA
I_{CCDR}	VCCDR supply current			4		mA
I_{BOOTx}	BOOTx supply current			1.5		mA
$UVLO_{VCC}$	VCC turn-ON	VCC rising			4.5	V
	VCC turn-OFF	VCC falling	4			V
Oscillator						
F_{SW}	Main oscillator accuracy		180	200	220	kHz
	Oscillator adjustability	$R_{OSC} = 36\text{k}\Omega$	425	500	575	kHz
ΔV_{OSC}	PWM ramp amplitude	CORE and NB section		1.5		V
FAULT	Voltage at pin OSC	OVP, UVP latch active	3		3.6	V
EN	Turn-OFF threshold	OSC/EN falling	0.3			V
PVI / SVI interface						
PWROK	Input high		1.3			V
	Input low				0.80	V
VID2./SVD VID3/SVC	Input high	(SVI mode)	0.95			V
	Input low	(SVI mode)			0.65	V
SVD	Voltage low (ACK)	$I_{SINK} = -5\text{mA}$			250	mV
VID0 to VID5	Input high	(PVI mode)	1.3			V
	Input low	(PVI mode)			0.80	V
V_FIX	Entering V_FIX mode	VID0/V_FIX rising	3			V
Power manager I²C						
SDA, SCL	Input high		1.3			V
	Input low				0.8	V
SDA	Voltage low (ACK)	$I_{SINK} = -5\text{mA}$			250	mV

Table 5. Electrical characteristics (continued)

Symbol	Parameter	Test conditions	Min.	Typ.	Max.	Unit
Voltage positioning (CORE and NB section)						
CORE	Output voltage accuracy	VSEN to V _{CORE} ; FBG to GND _{CORE}	-8		8	mV
NB		NB_VSEN to V _{NB} ; NBFBG to GND _{FB}	-10		10	mV
OS	OFFSET bias voltage	I _{2DIS} =3.3V, I _{OS} = 0 to 250μA	1.190	1.24	1.290	V
	OFFSET current range	I _{2DIS} =3.3V	0		250	μA
	OFFSET - I _{FB} accuracy	I _{2DIS} =3.3V, I _{OS} = 0μA	-2.25		2.25	μA
I _{2DIS} =3.3V, I _{OS} = 250μA		-9		9	μA	
DROOP	DROOP accuracy	I _{DROOP} = 0 to 25μA, k _{DRP} = 1/4	-3		3	μA
		I _{NB_DROOP} = 0 to 6μA, k _{NBDRP} = 1/4	-1		1	μA
A ₀	EA DC gain			100		dB
SR	Slew rate	COMP, NB_COMP to SGND = 10pF		20		V/μs
PWM outputs (CORE only) and embedded drivers						
PWM3, PWM4	Output high	I = 1mA	3		3.6	V
	Output low	I = -1mA			0.2	V
I _{PWMx}	Test current			10		μA
High current embedded drivers						
R _{HIHS}	HS source resistance	BOOT - PHASE = 12V; 100mA		2.3	2.8	Ω
I _{UGATE}	HS source current	BOOT - PHASE = 12V; ⁽¹⁾ C _{UGATE} to PHASE = 3.3nF		2		A
R _{LOHS}	HS sink resistance	BOOT - PHASE = 12V; 100mA		2	2.5	Ω
R _{HILS}	LS source resistance	100mA		1.3	1.8	Ω
I _{LGATE}	LS source current	C _{LGATE} to GND = 5.6nF, ⁽¹⁾		3		A
R _{LOLS}	LS sink resistance	100mA		1	1.5	Ω
Protections						
OVP	Over voltage protection	I ² C enabled, no commands issued, wrt VID, CORE & NB section	+200	+250	+300	mV
		I ² C disabled, V _{FIX} mode; VSEN, NB_VSEN rising		1.800		V
	SDA/OVP bias current	I _{2CDIS} = 3.3V	9	11	13	μA
UVP	Under voltage protection	VSEN, NB_VSEN falling; wrt Ref.	-450	-400	-350	mV
PWRGOOD	PGOOD threshold	VSEN, NB_VSEN falling; wrt Ref	-285	-250	-215	mV
	Voltage low	I _{PWRGOOD} = -4mA			0.4	V
V _{FB-DISC}	FB disconnection	V _{CSN} rising, above VSEN CORE and NB sections		600		mV
V _{FBG DISC}	FBG disconnection	EA NI input wrt VID		500		mV

Table 5. Electrical characteristics (continued)

Symbol	Parameter	Test conditions	Min.	Typ.	Max.	Unit
V_{OC_TOT}			2.425	2.500	2.575	V
kI_{ILIM}	CORE OC	$I_{LIM} = 0\mu A$	0		4	μA
		$I_{LIM} = 100\mu A$		100		μA

1. Parameter(s) guaranteed by designed, not fully tested in production

4 Device description and operation

L6717 is a hybrid CPU power supply controller compatible with both parallel (PVI) and serial (SVI) protocols for AMD Processors. The device provides complete control logic and protections for a high-performance step-down DC-DC voltage regulator, optimized for advanced microprocessor power supply supporting both PVI and SVI communication. It embeds two independent controllers for CPU CORE and the integrated NB, each one with its own set of protections. NB phase (when enabled) is automatically phase-shifted with respect to the CORE phases in order to reduce the total input rms current amount.

The device features an additional power manager I²C interface to ease the system design for enthusiastic application where the main parameters of the voltage regulator have to be modified. L6717 is able to adjust the regulated voltage, the switching frequency and also the OV protection threshold through the power manager I²C bus while the application is running assuring fast and reliable transitions.

Dynamic phase management (DPM) allows the device to automatically adjust the phase count according to the current delivered to the load. This feature allow the system to keep alive only the phases really necessary to sustain the load saving in power dissipation so optimizing the efficiency over the whole current range of the application. DPM can be enabled through the power manager I²C bus.

L6717 is able to detect which kind of CPU is connected in order to configure itself to work as a single-plane PVI controller or dual-plane SVI controller.

The controller performs a single-phase control for the NB section and a programmable 2-to-4 phase control for the CORE section featuring dual-edge non-latched architecture: this allows fast load-transient response optimizing the output filter consequently reducing the total BOM cost. Further reduction in output filter can be achieved by enabling LTB Technology[®].

PSI_L flag is sent to the VR through the SVI bus. The controller monitors this flag and selectively modifies the phase number in order to optimize the system efficiency when the CPU enters low-power states. This causes the over-all efficiency to be maximized at light loads so reducing losses and system power consumption.

Both sections feature programmable overvoltage protection and adjustable constant overcurrent protection. Voltage positioning (LL) is possible thanks to an accurate fully-differential current-sense across the main inductors for both sections.

L6717 features dual remote sensing for the regulated outputs (CORE and NB) in order to recover from PCB voltage drops also protecting the load from possible feedback network disconnections.

LSLess start-up function allows the controller to manage pre-biased start-up avoiding dangerous current return through the main inductors as well as negative undershoot on the output voltage if the output filter is still charged before start-up.

L6717 supports V_FIX mode for system debugging: in this particular configuration the SVI bus is used as a static bus configuring 4 operative voltages for both the sections and ignoring any serial-VID command.

When working in PVI mode, the device features on-the-fly VID management: VID code is continuously sampled and the reference update according to the variation detected,

L6717 is available in VFQFPN48 package.

5 Hybrid CPU support and CPU_TYPE detection

L6717 is able to detect the type of the CPU-core connected and to configure itself accordingly. At system Start-up, on the rising-edge of the EN signal, the device monitors the status of VID1 and configures the PVI mode (VID1 = 1) or SVI mode (VID1 = 0).

When in PVI mode, L6717 uses the information available on the VID[0: 5] bus to address the CORE Section output voltage according to [Table 6](#). NB Section is kept in HiZ mode, both MOSFETs are kept OFF.

When in SVI mode, L6717 ignores the information available on VID0, VID4 and VID5 and uses VID2 and VID3 as a SVI bus addressing the CORE and NB Sections according to the SVI protocol.

Caution: To avoid any risk of errors in CPU type detection (i.e. detecting SVI CPU when PVI CPU is installed on the socket and vice versa), it is recommended to carefully control the start-up sequencing of the system hosting L6717 in order to ensure that on the EN rising-edge, VID1 is in valid and correct state. Typical connections consider VID1 connected to CPU CORE_TYPE through a resistor to correctly address the CPU detection.

5.1 PVI - parallel interface

PVI is a 6-bit-wide parallel interface used to address the CORE section reference. According to the selected code, the device sets the CORE section reference and regulates its output voltage as reported into [Table 6](#).

NB section is always kept in HiZ; no activity is performed on this section and both the high-side and low-side of this section are kept OFF. Furthermore, PWROK information is ignored as well since the signal only applies to the SVI protocol.

5.2 PVI start-up

Once the PVI mode has been detected, the device uses the whole code available on the VID[0:5] lines to define the reference for the CORE section. NB section is kept in HiZ. Soft-start to the programmed reference is performed regardless of the state of PWROK.

See [Section 7.8](#) for details about soft-start.

Table 6. Voltage Identifications (VID) codes for PVI mode

VID5	VID4	VID3	VID2	VID1	VID0	Output voltage	VID5	VID4	VID3	VID2	VID1	VID0	Output voltage
0	0	0	0	0	0	1.5500	1	0	0	0	0	0	0.7625
0	0	0	0	0	1	1.5250	1	0	0	0	0	1	0.7500
0	0	0	0	1	0	1.5000	1	0	0	0	1	0	0.7375
0	0	0	0	1	1	1.4750	1	0	0	0	1	1	0.7250
0	0	0	1	0	0	1.4500	1	0	0	1	0	0	0.7125
0	0	0	1	0	1	1.4250	1	0	0	1	0	1	0.7000
0	0	0	1	1	0	1.4000	1	0	0	1	1	0	0.6875
0	0	0	1	1	1	1.3750	1	0	0	1	1	1	0.6750
0	0	1	0	0	0	1.3500	1	0	1	0	0	0	0.6625
0	0	1	0	0	1	1.3250	1	0	1	0	0	1	0.6500
0	0	1	0	1	0	1.3000	1	0	1	0	1	0	0.6375
0	0	1	0	1	1	1.2750	1	0	1	0	1	1	0.6250
0	0	1	1	0	0	1.2500	1	0	1	1	0	0	0.6125
0	0	1	1	0	1	1.2250	1	0	1	1	0	1	0.6000
0	0	1	1	1	0	1.2000	1	0	1	1	1	0	0.5875
0	0	1	1	1	1	1.1750	1	0	1	1	1	1	0.5750
0	1	0	0	0	0	1.1500	1	1	0	0	0	0	0.5625
0	1	0	0	0	1	1.1250	1	1	0	0	0	1	0.5500
0	1	0	0	1	0	1.1000	1	1	0	0	1	0	0.5375
0	1	0	0	1	1	1.0750	1	1	0	0	1	1	0.5250
0	1	0	1	0	0	1.0500	1	1	0	1	0	0	0.5125
0	1	0	1	0	1	1.0250	1	1	0	1	0	1	0.5000
0	1	0	1	1	0	1.0000	1	1	0	1	1	0	0.4875
0	1	0	1	1	1	0.9750	1	1	0	1	1	1	0.4750
0	1	1	0	0	0	0.9500	1	1	1	0	0	0	0.4625
0	1	1	0	0	1	0.9250	1	1	1	0	0	1	0.4500
0	1	1	0	1	0	0.9000	1	1	1	0	1	0	0.4375
0	1	1	0	1	1	0.8750	1	1	1	0	1	1	0.4250
0	1	1	1	0	0	0.8500	1	1	1	1	0	0	0.4125
0	1	1	1	0	1	0.8250	1	1	1	1	0	1	0.4000
0	1	1	1	1	0	0.8000	1	1	1	1	1	0	0.3875
0	1	1	1	1	1	0.7750	1	1	1	1	1	1	0.3750

5.3 SVI - serial interface

SVI is a two wire, clock and data, bus that connects a single master (CPU) to one slave (L6717). The master initiates and terminates SVI transactions and drives the clock, SVC, and the data, SVD, during a transaction. The slave receives the SVI transactions and acts accordingly. SVI wire protocol is based on fast-mode I²C.

SVI interface also considers two additional signal needed to manage the system start-up. These signals are EN and PWROK. The device return a PWRGOOD signal if the output voltages are in regulation.

5.4 SVI start-up

Once the SVI mode has been detected on the EN rising-edge, L6717 checks for the status of the two serial VID pins, SVC and SVD, and stores this value as the *Pre-PWROK Metal VID*. The controller initiate a soft-start phase regulating both CORE and NB voltage planes to the voltage level prescribed by the *Pre-PWROK Metal VID*. See [Table 7](#) for details about *Pre-PWROK Metal VID* codifications. The stored *Pre-PWROK Metal VID* value are re-used in any case of PWROK de-assertion.

After bringing the output rails into regulation, the controller asserts the PWRGOOD signal and waits for PWROK to be asserted. Until PWROK is asserted, the controller regulates to the *Pre-PWROK Metal VID* ignoring any commands coming from the SVI interface.

After PWROK is asserted, the processor has initialized the serial VID interface and L6717 waits for commands from the CPU to move the voltage planes from the *Pre-PWROK Metal VID* values to the operative VID values. As long as PWROK remains asserted, the controller will react to any command issued through the SVI interface according to SVI protocol.

See [Section 7.8](#) for details about Soft-Start.

Table 7. V_FIX mode and Pre-PWROK MetalVID

SVC	SVD	Output voltage [V]	
		<i>Pre-PWROK metal VID</i>	<i>V_FIX mode</i>
0	0	1.1V	1.4V
0	1	1.0V	1.2V
1	0	0.9V	1.0V
1	1	0.8V	0.8V

5.4.1 Set VID command

The *set VID command* is defined as the command sequence that the CPU issues on the SVI bus to modify the voltage level of the CORE section and/or the NB section.

During a *set VID command*, the processor sends the start (START) sequence followed by the address of the section which the *set VID command* applies. The processor then sends the write (WRITE) bit. After the write bit, the voltage regulator (VR) sends the acknowledge (ACK) bit. The processor then sends the VID bits code during the *data phase*. The VR sends the acknowledge (ACK) bit after the data phase. Finally, the processor sends the stop (STOP) sequence. After the VR has detected the stop, it performs an on-the-fly VID

transition for the addressed section(s) or, more in general, react to the sent command accordingly. Refer to [Figure 6](#), [Table 8](#) and [Table 9](#) for details about the *set VID Command*.

L6717 is able to manage individual power OFF for both the sections. The CPU may issue a serial VID command to power OFF or power ON one Section while the other one remains powered. In this case, the PWRGOOD signal remains asserted.

Figure 6. SVI Communications - send byte

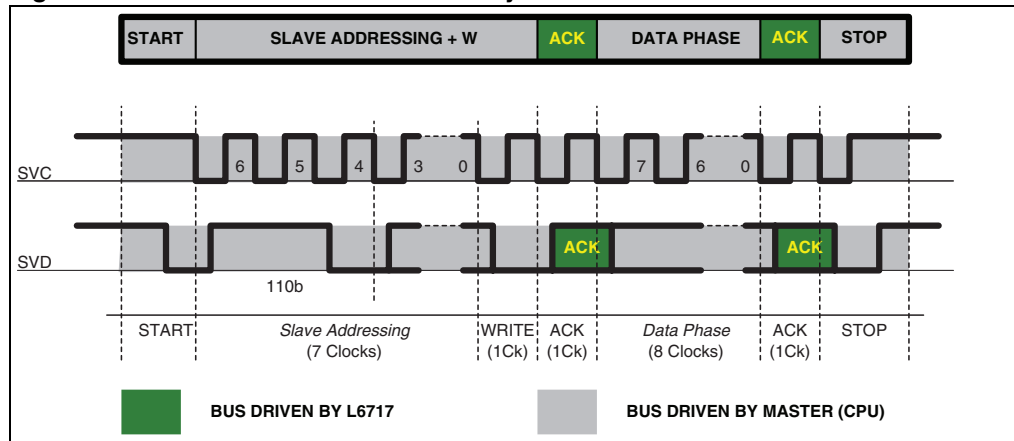

Table 8. SVI send byte - address and data phase description

bits	Description
Address phase	
6:4	Always 110b.
3	Not applicable, ignored.
2	Not applicable, ignored.
1	CORE section ⁽¹⁾ . If set then the following data byte contains the VID code for CORE section.
0	NB section ⁽¹⁾ . If set then the following data byte contains the VID code for NB section.
Data phase	
7	PSI_L flag (Active low). When asserted, the VR is allowed to enter power-saving mode. See Section 5.4.3 .
6:0	VID code. See Table 9 .

1. Assertion in both bit 1 and 0 will address the VID code to both CORE and NB simultaneously.

Table 9. Data phase - serial VID codes

SVI [6:0]	Output voltage	SVI [6:0]	Output voltage	SVI [6:0]	Output voltage	SVI [6:0]	Output voltage
000_0000	1.5500	010_0000	1.1500	100_0000	0.7500	110_0000	0.3500
000_0001	1.5375	010_0001	1.1375	100_0001	0.7375	110_0001	0.3375
000_0010	1.5250	010_0010	1.1250	100_0010	0.7250	110_0010	0.3250
000_0011	1.5125	010_0011	1.1125	100_0011	0.7125	110_0011	0.3125
000_0100	1.5000	010_0100	1.1000	100_0100	0.7000	110_0100	0.3000
000_0101	1.4875	010_0101	1.0875	100_0101	0.6875	110_0101	0.2875
000_0110	1.4750	010_0110	1.0750	100_0110	0.6750	110_0110	0.2750
000_0111	1.4625	010_0111	1.0625	100_0111	0.6625	110_0111	0.2625
000_1000	1.4500	010_1000	1.0500	100_1000	0.6500	110_1000	0.2500
000_1001	1.4375	010_1001	1.0375	100_1001	0.6375	110_1001	0.2375
000_1010	1.4250	010_1010	1.0250	100_1010	0.6250	110_1010	0.2250
000_1011	1.4125	010_1011	1.0125	100_1011	0.6125	110_1011	0.2125
000_1100	1.4000	010_1100	1.0000	100_1100	0.6000	110_1100	0.2000
000_1101	1.3875	010_1101	0.9875	100_1101	0.5875	110_1101	0.1875
000_1110	1.3750	010_1110	0.9750	100_1110	0.5750	110_1110	0.1750
000_1111	1.3625	010_1111	0.9625	100_1111	0.5625	110_1111	0.1625
001_0000	1.3500	011_0000	0.9500	101_0000	0.5500	111_0000	0.1500
001_0001	1.3375	011_0001	0.9375	101_0001	0.5375	111_0001	0.1375
001_0010	1.3250	011_0010	0.9250	101_0010	0.5250	111_0010	0.1250
001_0011	1.3125	011_0011	0.9125	101_0011	0.5125	111_0011	0.1125
001_0100	1.3000	011_0100	0.9000	101_0100	0.5000	111_0100	0.1000
001_0101	1.2875	011_0101	0.8875	101_0101	0.4875	111_0101	0.0875
001_0110	1.2750	011_0110	0.8750	101_0110	0.4750	111_0110	0.0750
001_0111	1.2625	011_0111	0.8625	101_0111	0.4625	111_0111	0.0625
001_1000	1.2500	011_1000	0.8500	101_1000	0.4500	111_1000	0.0500
001_1001	1.2375	011_1001	0.8375	101_1001	0.4375	111_1001	0.0375
001_1010	1.2250	011_1010	0.8250	101_1010	0.4250	111_1010	0.0250
001_1011	1.2125	011_1011	0.8125	101_1011	0.4125	111_1011	0.0125
001_1100	1.2000	011_1100	0.8000	101_1100	0.4000	111_1100	OFF
001_1101	1.1875	011_1101	0.7875	101_1101	0.3875	111_1101	OFF
001_1110	1.1750	011_1110	0.7750	101_1110	0.3750	111_1110	OFF
001_1111	1.1625	011_1111	0.7625	101_1111	0.3625	111_1111	OFF

5.4.2 PWROK de-assertion

Anytime PWROK de-asserts, while EN is asserted, the controller uses the previously stored *Pre-PWROK Metal VID* and sets both CORE and NB planes voltage to the corresponding level performing an on-the-fly VID transition.

Anytime the PWROK is de-asserted the PWRGOOD is tied low; after being pulled low the PWRGOOD is treated appropriately and kept de-asserted until the output voltage of both CORE and NB sections is within the PWRGOOD validity window referred to *Pre-PWROK Metal VID*.

5.4.3 PSI_L and efficiency optimization at light-load

PSI_L is an active-low flag (i.e. low logic level when asserted) that can be set by the CPU to allow the VR to enter power-saving mode to maximize the system efficiency when in light-load conditions. The status of the flag is communicated to the controller through the SVI bus.

When the PSI_L flag is asserted by the CPU through the SVI bus, the device adjusts the phase number according to the programmed strategy. Default PSI_L strategy consists in working in single phase. PSI_L strategy can be disabled as well as re-configured through specific Power Manager I²C commands. See [Section 6](#) for details.

When CPU issues PSI_L flag, L6717 adjusts phase number according to the selected PSI_L strategy: the device sets HiZ on the related phases and re-configures internal phase-shift to maintain the correct interleaving among active phases. Furthermore, the internal current-sharing is adjusted considering the phase number reduction.

When PSI_L is de-asserted, the device will return to the original configuration.

Start-up is performed with all the configured phases enabled.

When PSI_L is active L6717 performs on-the-fly VID transitions with all the programmed phases.

NB section is not impacted by PSI_L status change.

[Figure 7](#) shows an example of the efficiency improvement that can be achieved by enabling the PSI management.

Figure 7. System efficiency enhancement by PSI

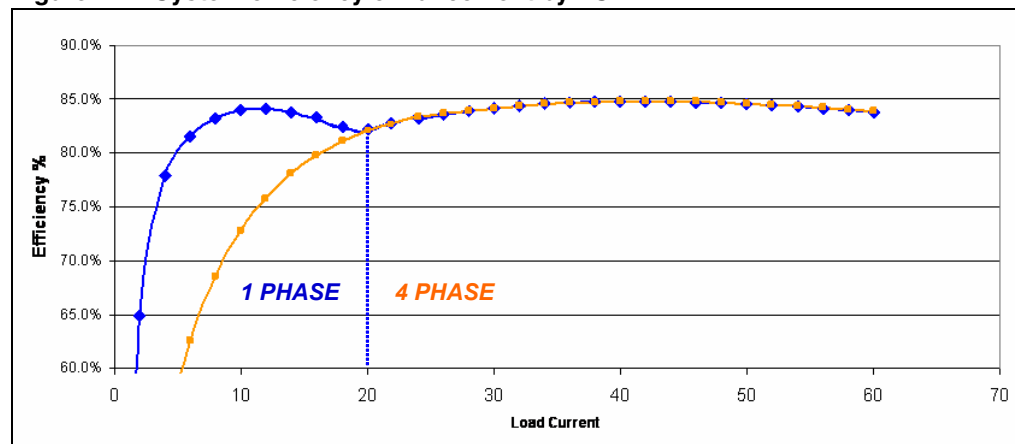

5.4.4 HiZ management

L6717 is able to manage HiZ both for internal driver and for external drivers through the PWMx signals. When the controller needs to set HiZ state for a phase or section, it sets the corresponding PWMx pin floating and, at the same time, turn OFF both HS and LS MOSFETs by proper action of the corresponding embedded driver.

5.4.5 Hardware jumper override - V_FIX

VID0/V_FIX pin allows the device to operate in V_FIX mode.

Anytime L6717 is enabled it checks the pin VID0/V_FIX voltage level: pull up VID0/V_FIX to 3.3V to enter V_FIX mode.

When in V_FIX mode, both NB and CORE Section voltages are governed by the information shown in [Table 7](#).

Regardless of the state of VID1, the device will work in SVI mode and furthermore PWROK logic level is ignored.

SVC and SVD are considered as static VID and the output voltage changes according to their status. Dynamic SVC/SVD-change management is provided in this condition.

V_FIX mode is intended for system debug only.

Protection management differs in this case, see [Section 8.1](#) for details.

6 Power manager I²C

L6717 features a secondary power manager I²C bus to ease the implementation of power management features as well as over-speeding for “enthusiastic” users. The power manager I²C bus is operative after the PWRGOOD signal is driven high at the end of the soft-start.

Power manager I²C is a two wire, SCL (Clock) and SDA (Data), bus connecting a single master to one or more slaves (L6717) separately addressable. The master initiates and terminates I²C transactions and drives both the clock, SCL, and the data, SDA, during a transaction. The slave receives the I²C transactions and acts accordingly.

Power manager I²C wire protocol is based on fast-mode I²C.

Power manager I²C address configuration can be programmed through ADDR pin while I2CDIS pin allows to disable the bus. See [Table 10](#).

Power manager I²C and SVI bus are two independent buses working in parallel. In case two commands are issued in the same time on the two buses, L6717 performs them in the same time.

Table 10. Power manager I²C configuration

I2CDIS	ADDR	Description
3.3V	n/a	Power manager I ² C disabled. SDA/OVP now becomes OVP to program the OV threshold for both CORE and NB sections. SCL/OS now becomes OS to program Offset for the CORE section.
OPEN	3.3V	It sets I ² C address to 1100111.
	OPEN	It sets I ² C address to 1100110 (default).

6.1 Power manager commands

Power manager I²C master issues different command sequences to modify several voltage positioning parameters for CORE and/or NB Sections of L6717.

Moreover the power manager I²C commands allow to configure DPM and other power-saving-related features.

During a *power manager command*:

- The bus master sends the start (START) sequence followed by the *address* of the controller which the *power manager command* applies. The bus master then sends the write (WRITE) bit. After the write bit, the voltage regulator (VR, L6717) sends the acknowledge (ACK) bit.
- The bus master sends the command code during the *command phase*. The VR (L6717) sends the acknowledge (ACK) bit after the command phase.
- The bus master sends the *data stream* related to the command phase previously issued (if applicable). The VR (L6717) sends the acknowledge (ACK) bit after the data stream. Finally, the bus master sends the stop (STOP) sequence.
- After the VR (L6717) has detected the STOP sequence, it performs operations according to the command issued by the bus master.

Refer to [Figure 8](#), [Table 11](#) and [Table 12](#) for details.

Figure 8. Power manager I²C communication format

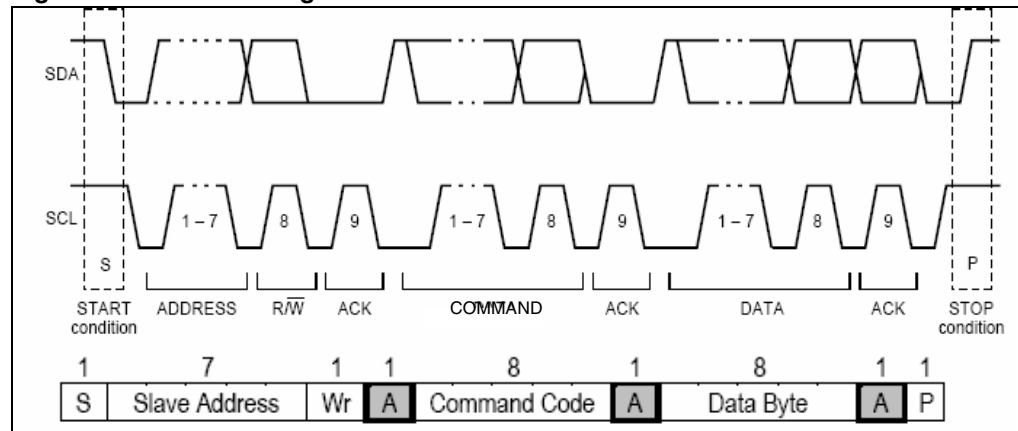

Table 11. Power manager I²C - address and command phase description

bits	Description
Address phase	
1:6	Always 110011b.
7	Slave address. According to ADDR connection, the device will act if addressed by 0b or 1b. Default address bit is 0b.
8	WRITE bit.
Command phase	
1:3	Not applicable, ignored.
4:6	Command code
7, 8	Not applicable, ignored.

Table 12. Power manager I²C command phase and data stream

Command code [4:6]	Data stream [1:8]	Description
1CN	[1:2] xx [3] SIGN [4:8] OVRSPD	<p>OVERSPEEDING: Adds a positive/negative offset to the regulation according to the SIGN bit with 50mV LSB and 5bit resolution.</p> <p>[3] SIGN: 1b for positive offset, 0b for negative offset. Negative offset is applicable only to CORE section (NB does not react to negative OS command)</p> <p>[4:8] OVRSPD: 5bit code (4:MSB to 8:LSB), defines the offset to add to the programmed reference (VID). Maximum CORE output voltage reachable is limited to 2.8V. Maximum NB output voltage reachable is limited by the Maximum NB Offset: +600mV (over VID)</p> <p>“CN” bits in <i>command code</i> address CORE section (“C” bit) or NB section (“N” bit) if set to 1b. Asserting both C and N bits will apply the command to both CORE and NB section. See Table 13 for details about OVRSPD codification.</p>
000	[1:4] xxxx [5:6] OV_NB [7:8] OV_CORE	<p>OV_SET: Overvoltage threshold setup for CORE and/or NB sections. Sets the OV threshold above the programmed VID (including OVRSPD) in with three 200mV steps from + 250mV up to +850mV (up to 650mV for NB).</p> <p>[1:4]: ignored</p> <p>[5:6] OV_NB: <i>NorthBridge OVP</i>. 2bit code, defines the OV threshold for the NB section above the programmed reference (VID).</p> <p>[7:8] OV_CORE: <i>Core OVP</i>. 2bit code, defines the OV threshold for the CORE section above the programmed reference (VID).</p> <p>Default OV threshold is +250mV above reference for both sections. See Table 14 for details about OV_SET codification.</p>
001	[1:5] xxxxx [6:8] FSW	<p>FSW_ADJ: Switching frequency adjustment. Modifies the switching frequency programmed through OSC pin according to FSW code by +/- 10% or +/-20%.</p> <p>[1:5]: ignored</p> <p>[6:8] FSW: <i>Switching frequency adjustment</i>. 3 bits code to adjust the switching frequency with respect programmed voltage. See Table 15 for details about FSW_ADJ codification.</p>

Table 12. Power manager I²C command phase and data stream

Command code [4:6]	Data stream [1:8]	Description
010	[1:4] XXXX [5:6] k _{DRPNB} [7:8] k _{DRP}	<i>DRP_ADJ</i> : Droop function adjustment. Modifies the slope of the output voltage implemented through the droop function. [1:4]: ignored [5:6]: k _{DRPNB} : Defines the k _{DRP} factor for NB section. [7:8]: k _{DRP} : Defines the k _{DRPNB} factor for CORE section. Default value is k _{DRP_x} = 1/4 for both sections. See Table 16 for details about DRP_ADJ codification and Section 7.3 and Section 7.6 for LoadLine definition.
011	[1:3] xxx [4:5] DPMTH [6] PSI_A [7] PSI_EN [8] DPM_ON	<i>Power management flags</i> : Set of three flags to define power management actions of the controller. [1:3]: ignored [4:5]: DPM thresholds. Default is 00b. [6] PSI_A: <i>PSI action</i> . It defines the action to take when PSI_L flag is asserted by SVI bus. The same action is considered by DPM. Send 0b to work in single phase (default) or 1b to work at two phases. [7] PSI_EN: <i>PSI enable</i> . It enables or disables the PSI management. Set to 1b (default) to manage PSI_L according to PSI_A or set to 0b to ignore PSI_L flag sent through SVI bus. [8] DPM_ON: <i>Dynamic phase management</i> . It enables or disables the DPM mode. Set to 1b to enable DPM or set to 0b (default) to disable it. When enabled DPM acts automatically cutting phases according to PSI action flag at light load. See Section 6.2 for details about DPM.

6.1.1 Overspeeding command (OVRSPD)

This command allows to add a variable positive/negative offset to the CORE and/or NB reference programmed by the SVI bus in order to overspeed the CPU. L6717 allows adding up to 1.550 V in 50 mV steps to the reference.

The maximum possible output voltage for CORE section is internally limited to 2.8 V. In case the SVI programmed reference plus the offset set through the OVRSPD command exceed this value, the reference for the regulation is clamped to 2.8 V.

The maximum possible output voltage for NB section is internally limited by the maximum offset achievable for NB section that is +600 mV over the SVI programmed reference.

Once the controller acknowledges the command and recognizes the OVRSPD command, the reference will step up or down until reaching the target offset performing a on-the-fly VID transition. In case a new overspeed command is issued while the output voltage is not yet stabilized (i.e. the reference is still stepping to the target), the target is updated according to the new offset defined.

The command addresses both sections through two separate bits in the command code ("CN" bits - See [Table 12](#)). By asserting the corresponding bit, the subsequent data stream will apply to the identified section. Asserting both bits ("CN" = 11b) will address both sections. CN = 00b will be ignored regardless of the data Stream provided. "CN" = 10b and "CN" = 01b allow to address only CORE or only NB section respectively.

See [Table 12](#) and [Table 13](#) for details about the codification of the command and the data stream.

Table 13. OVRSPD command - offset codification ⁽¹⁾ ⁽²⁾

Data stream [4:8]	Offset to reference [V]	Data stream [4:8]	Offset to reference [V]	Data stream [4:8]	Offset to reference [V]	Data stream [4:8]	Offset to reference [V]
0000	0.00	01000	0.40	10000	0.80	11000	1.20
00001	0.05	01001	0.45	10001	0.85	11001	1.25
00010	0.10	01010	0.50	10010	0.90	11010	1.30
00011	0.15	01011	0.55	10011	0.95	11011	1.35
00100	0.20	01100	0.60	10100	1.00	11100	1.40
00101	0.25	01101	0.65	10101	1.05	11101	1.45
00110	0.30	01110	0.70	10110	1.10	11110	1.50
00111	0.35	01111	0.75	10111	1.15	11111	1.55

1. Offset is added with an OTF VID transition above the programmed VID.
2. Maximum regulated output voltage is internally limited to 2.8V maximum: regardless the offset over VID reference the IC does not allow to reach an higher voltage.

6.1.2 Overvoltage threshold adjustment (OV_SET)

This command allows to adjust the overvoltage threshold independently for CORE and NB Sections. The default OVP threshold value of +250 mV over the reference is adjustable, in 200 mV steps up to +850 mV above the reference for CORE and +650 mV above the reference for NB.

See [Table 12](#) and [Table 14](#) for details about the codification of the command and the data stream.

Table 14. OVP_SET command - threshold codification

Data stream [5:6] and [7:8]	OVP threshold [V]
00	+250mV (Default)
01	+450mV
10	+650mV
11	+850mV CORE / +650mV for NB

6.1.3 Switching frequency adjustment (FSW_ADJ)

This command allows to adjust the switching frequency for the system in +/-10% steps across the main level defined by the OSC pin. Switching frequency margining may benefit the system from the thermal and performance point of view.

See [Table 12](#) and [Table 15](#) for details about the codification of the command and the data stream.

Table 15. FSW_ADJ command - switching frequency adjustment codification

Data stream [6:8]	Fsw adjustment	Data stream [6:8]	Fsw adjustment
000	Reset to frequency programmed by OSC	100	Reset to frequency programmed by OSC
001	-10%	101	+10%
010	-20%	110	+20%
011	Ignored	111	Ignored

6.1.4 Droop function adjustment (DRP_ADJ)

This command allows to adjust the slope for the output voltage load line once the external components are defined by modifying the k_{DRP} and k_{DRPNB} parameters defined in [Section 7.3](#) and [Section 7.6](#).

See [Table 12](#) and [Table 16](#) for details about the codification of the command and the data stream.

Table 16. DRP_ADJ command - droop function adjustment codification

Data stream [5:6] and [7:8]	DRP adjustment $k_{DRPNB}[5:6]$ and $k_{DRP}[7:8]$
00	1/4
01	1/2
10	Ignored
11	Droop disabled

6.1.5 Power management flags

This command allows to set several flags to configure L6717 power management.

The flags allows to define:

- **PSI_A**. This flag defines phase shedding strategy adopted when CPU asserts **PSI_L** by SVI bus. Set **PSI_A** = 0b (default) to program the device to work in single phase or set **PSI_A** = 1b to program two phase mode.
The selected strategy applies also to DPM mode.
See [Section 5.4.3](#) for details about PSI management and light-load efficiency optimizations. See [Section 6.2](#) for details about DPM.
- **PSI_EN**. This flag defines whether to enable or not the **PSI_L** management. Default is to manage **PSI_L** flag assertion through SVI bus (**PSI_EN** = 1b).
- **DPM_ON**. This flag defines whether to enable or not the DPM mode. The strategy adopted by DPM is defined through the **PSI_A** flag. See [Section 6.2](#) for details about DPM. DPM is disabled by default (**DPM_ON** = 0h).
- **DPMTH**. Allow to program up to 4 different strategies for DPM mode by properly adjusting the V_{DPM} threshold. See [Section 6.2](#) for details about DPM.

See [Table 12](#) and [Table 17](#) for details about the codification of the command and the data stream.

Table 17. Power management flags

Data stream bit	Flag	Description
[1:3]	n/a	Ignored.
[4:5]	DPMTH	DPM threshold. Allow to define 4 different values for V_{DPM} . See Section 6.2 for code/thresholds correspondence.
[6]	PSI_A	0b (default): IC working in single phase when PSI_L asserted. 1b: IC working in two phase when PSI_L asserted.
[7]	PSI_EN	0b: PSI_L flag in SVI ignored. 1b (default): PSI_L flag in SVI monitored and phase dropping enabled according to PSI_A.
[8]	DPM_ON	0b (default): DPM disabled. 1b: DPM enabled.

6.2 Dynamic phase management (DPM)

Dynamic phase management allows to adjust the number of working phases according to the delivered current still maintaining the benefits of the multiphase regulation.

Phase number is reduced by monitoring the voltage level across ILIM pin: L6717 reduces the number of working phase according to the strategy defined by the PSI_A flag when the voltage across ILIM pin is lower than V_{DPM} . When the load current increases the phase number is restored to the original value as soon as the voltage across ILIM pin exceeds V_{DPM} .

V_{DPM} is selected through the DPMTH command. See [Section 6.1](#).

The current at which the transition happens (I_{DPM}) can be estimated as:

$$I_{DPM} = \frac{V_{DPM}}{R_{ILIM}} \cdot \frac{R_G}{DCR}$$

V_{DPM} thresholds are defined as a percentage of the voltage on ILIM pin corresponding to the Thermal Design Current of the application.

1.8V on ILIM pin corresponds to 100% of the load and DPM threshold are defined as a percentage of 1.8V (see [Table 18](#) for details).

An hysteresis is provided for each threshold in order to avoid multiple DPM actions triggering in steady load conditions.

Table 18. V_{DPM} thresholds

CODE	V_{DPM} (I_{LIM} rising)	V_{DPM} (I_{LIM} falling)
00 (default)	20%	15%
01	25%	20%
10	30%	25%
11	35%	30%

DPM is disabled by default: Soft-start is performed with all the available phases.

When the soft start is over and once PWRGOOD rise to Logic "1", L6717 can receive commands on power manager I²C bus to enable DPM.

Once DPM is enabled, L6717 starts monitoring the ILIM voltage: the voltage is compared with the internal V_{DPM} threshold defining the current level to trigger the number modification.

DPM is reset in particular conditions:

- during OTF VID transition issued by the CPU;
- when LTB Technology[®] detects a load transient.

After being reset, DPM is re-enabled with a proper delay: the phase number is again defined according to the ILIM pin voltage with respect V_{DPM} .

Delay in the intervention of DPM can be adjusted by properly sizing the filter across ILIM pin. Increasing the capacitance results in increased delay in the DPM intervention.

7 Output voltage positioning

Output voltage positioning is performed by selecting the controller operative-mode (*SVI*, *PVI* and *V_FIX*) and by programming the droop function and offset to the reference of both the sections (See [Figure 9](#)). The controller reads the current delivered by each section by monitoring the voltage drop across the DCR Inductors. The current (I_{DROOP} / I_{DROOP_NB}) sourced from the FB / NB_FB pin, directly proportional to the read current, causes the related section output voltage to vary according to the external R_{FB} / R_{FB_NB} resistor so implementing the desired load-line effect.

L6717 embeds a dual remote-sense buffer to sense remotely the regulated voltage of each Section without any additional external components. In this way, the output voltage programmed is regulated compensating for board and socket losses. Keeping the sense traces parallel and guarded by a power plane results in common mode coupling for any picked-up noise.

Figure 9. Voltage positioning

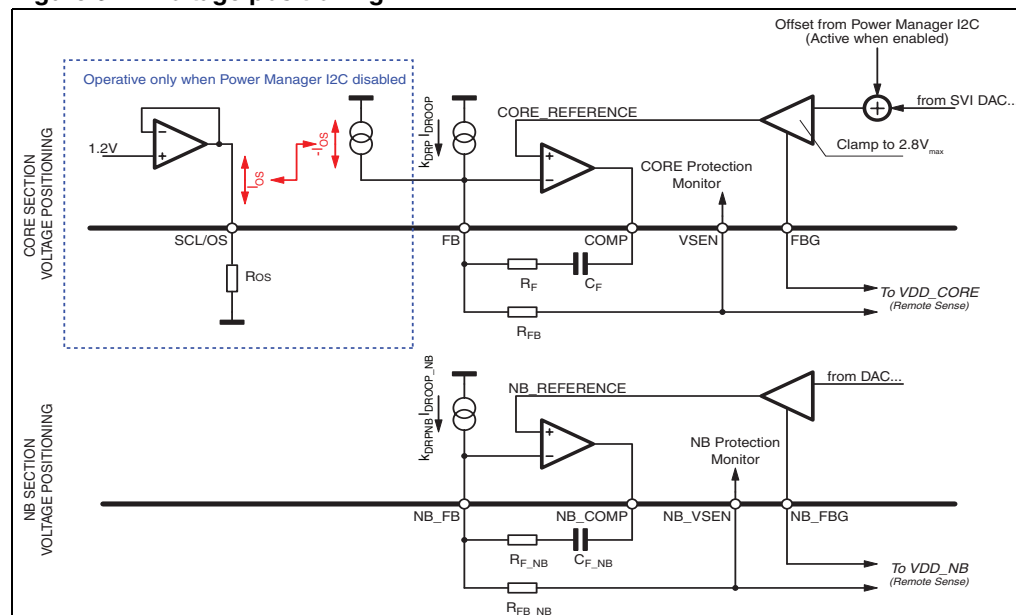

7.1 CORE section - phase # programming

CORE section implements a flexible 2 to 4 interleaved-phase converter. To program the desired number of phase, simply short to GND the PWMx signal that is not required to be used according to [Table 19](#). For three phase operation, short PWM4 to GND while for two phase operation, short PWM3 and PWM4 to GND.

Caution: For the disabled phase(s), the current reading pins need to be properly connected to avoid errors in current-sharing and voltage-positioning: CSxP needs to be connected to the regulated output voltage while CSxN needs to be connected to CSxP through the same R_G resistor used for the active phases. See [Figure 2](#) and [Figure 3](#) for details in 3-phase and 2-phase connections.

Table 19. CORE section - phase number programming

Phase number	PWM3	PWM4
2	GND	GND
3	To driver	GND
4	To driver	To driver

7.2 CORE section - current reading and current sharing loop

L6717 embeds a flexible, fully-differential current sense circuitry for the CORE Section that is able to read across inductor parasitic resistance or across a sense resistor placed in series to the inductor element. The fully-differential current reading rejects noise and allows placing sensing element in different locations without affecting the measurement's accuracy. The trans-conductance ratio is issued by the external resistor R_G placed outside the chip between CSxN pin toward the reading points. The current sense circuit always tracks the current information, the pin CSxP is used as a reference keeping the CSxN pin to this voltage. To correctly reproduce the inductor current an R-C filtering network must be introduced in parallel to the sensing element. The current that flows from the CSxN pin is then given by the following equation (See [Figure 10](#)):

$$I_{CSxN} = \frac{DCR}{R_G} \cdot \frac{1 + s \cdot L/DCR}{1 + s \cdot R \cdot C} \cdot I_{PHASEx}$$

Considering now to match the time constant between the inductor and the R-C filter applied (Time constant mismatches cause the introduction of poles into the current reading network causing instability. In addition, it is also important for the load transient response and to let the system show resistive equivalent output impedance) it results:

$$\frac{L}{DCR} = R \cdot C \Rightarrow I_{CSxN} = \frac{R_L}{R_G} \cdot I_{PHASEx} = I_{INFOx}$$

R_G resistor is typically designed in order to have an information current I_{INFOx} in the range of about $35\mu A$ (I_{OCTH}) at the OC Threshold.

Figure 10. Current reading

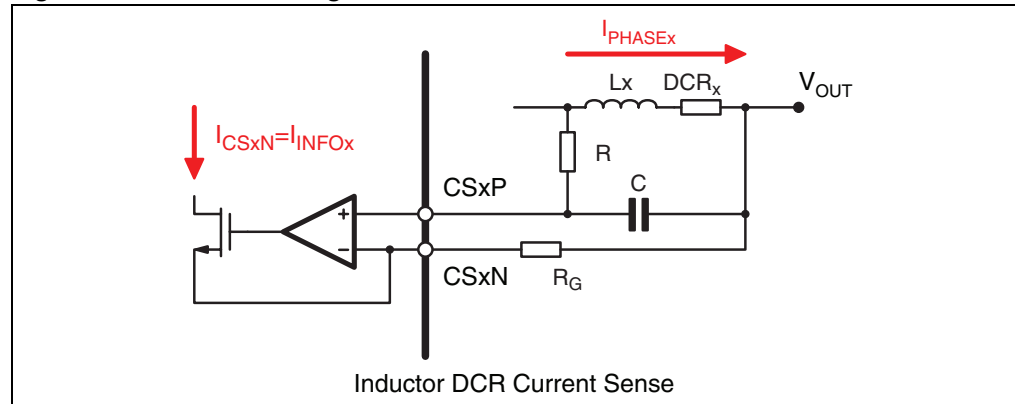

The current read through the CSxP / CSxN pairs is converted into a current I_{INFOx} proportional to the current delivered by each phase and the information about the average current $I_{AVG} = \sum I_{INFOx} / N$ is internally built into the device (N is the number of working phases). The error between the read current I_{INFOx} and the reference I_{AVG} is then converted into a voltage that with a proper gain is used to adjust the duty cycle whose dominant value is set by the voltage error amplifier in order to equalize the current carried by each phase.

7.3 CORE section - defining load-line

L6717 introduces a dependence of the output voltage on the load current recovering part of the drop due to the output capacitor ESR in the load transient. Introducing a dependence of the output voltage on the load current, a static error, proportional to the output current, causes the output voltage to vary according to the sensed current.

Figure 10 shows the current sense circuit used to implement the load-line. The current flowing across the inductor(s) is read through the R - C filter across CSxP and CSxN pins. R_G programs a trans-conductance gain and generates a current I_{CSx} proportional to the current of the phase. The sum of the I_{CSx} current, with proper gain defined by the DRP_ADJ command (k_{DRP}), is then sourced by the FB pin ($k_{DRP} I_{DROOP}$). R_{FB} gives the final gain to program the desired load-line slope (*Figure 9*).

Time constant matching between the inductor (L / DCR) and the current reading filter (RC) is required to implement a real equivalent output impedance of the system so avoiding over and/or under shoot of the output voltage as a consequence of a load transient. See *Section 7.2*. The output characteristic vs. load current is then given by:

$$V_{CORE} = VID - R_{FB} \cdot k_{DRP} \cdot I_{DROOP} = VID - k_{DRP} \cdot R_{FB} \cdot \frac{DCR}{R_G} \cdot I_{OUT} = VID - R_{LL} \cdot I_{OUT}$$

Where R_{LL} is the resulting load-line resistance implemented by the CORE Section. k_{DRP} value is determined by the Power Manager I^2C and its default value is 1/4.

R_{FB} resistor can be then designed according to the R_{LL} specifications and DRP_ADJ setting as follow:

$$R_{FB} = \frac{R_{LL}}{k_{DRP}} \cdot \frac{R_G}{DCR}$$

See *Section 6.2* for details about DRP_ADJ command.

7.4 CORE section - analog offset (Optional - I2CDIS = 3.3 V)

When power manager I²C is disabled (I2CDIS = 3.3 V), L6717 still provide the way to add positive/negative offset to the CORE section. In this particular conditions, the pin SCL/OS becomes a virtual ground and allows programming a positive/negative offset (V_{OS}) for the CORE section output voltage by connecting a resistor R_{OS} to SGND/VCC. The pin is internally fixed at 1.240 V (2.0 V in case of negative offset, R_{OS} tied to VCC) so a current is programmed by connecting the resistor R_{OS} between the pin and SGND/VCC: this current is mirrored and then properly sunk/sourced from the FB pin as shown in [Figure 9](#). Output voltage is then programmed as follow:

$$V_{CORE} = VID - R_{FB} \cdot (k_{DRP} \cdot I_{DROOP} - I_{OS})$$

Offset resistor can be designed by considering the following relationship (R_{FB} is be fixed by the droop effect):

$$R_{OS} = \frac{1.240V}{V_{OS}} \cdot R_{FB} \quad (\text{positive offset})$$

$$R_{OS} = \frac{VCC - 2.0V}{V_{OS}} \cdot R_{FB} \quad (\text{negative offset})$$

Caution: Offset implementation is optional, in case it is not desired, simply short the pin to GND.

Note: In the above formulas, R_{FB} has to be considered being the total resistance connected between FB pin and the regulated voltage. k_{DRP} has to be considered having its default value since power manager I²C is disabled.

7.5 NB section - current reading

NB section performs the same differential current reading across DCR as the CORE Section. According to [Section 7.2](#), the current that flows from the NB_CSN pin is then given by the following equation (See [Figure 10](#)):

$$I_{NB_CSN} = \frac{DCR(NB)}{R_{G_NB}} \cdot I_{NB} = I_{DROOP_NB}$$

R_{G_NB} resistor is typically designed according to the OC threshold. See [Section 8.4](#) for details.

7.6 NB section - defining load-line

This method introduces a dependence of the output voltage on the load current recovering part of the drop due to the output capacitor ESR in the load transient. Introducing a dependence of the output voltage on the load current, a static error, proportional to the output current, causes the output voltage to vary according to the sensed current.

[Figure 10](#) shows the current sense circuit used to implement the load-line. The current flowing across the inductor DCR is read through R_{G_NB} . R_{G_NB} programs a trans-conductance gain and generates a current I_{DROOP_NB} proportional to the current delivered by the NB Section that is then sourced from the NB_FB pin with proper gain defined by the DRP_ADJ

command (k_{DRPNB}). R_{FB_NB} gives the final gain to program the desired load-line slope (Figure 9).

The output characteristic vs. load current is then given by:

$$V_{OUT_NB} = VID - R_{FB_NB} \cdot k_{DRPNB} \cdot I_{DROOP_NB}$$

$$VID - R_{FB_NB} \cdot k_{DRPNB} \cdot \frac{DCR(NB)}{R_{G_NB}} \cdot I_{OUT} = VID - R_{LL_NB} \cdot I_{OUT_NB}$$

Where R_{LL_NB} is the resulting Load-Line resistance implemented by the NB Section. k_{DRPNB} value is determined by the Power Manager I²C and its default value is 1/4.

R_{FB_NB} resistor can be then designed according to the R_{LL_NB} specifications and DRP_ADJ setting as follow:

$$R_{FB_NB} = \frac{R_{LL_NB}}{k_{DRPNB}} \cdot \frac{R_{G_NB}}{DCR(NB)}$$

7.7 On-the-fly VID transitions

L6717 manages on-the-fly VID Transitions that allow the output voltage of both sections to modify during normal device operation for CPU power management purposes. OV, UV and PWRGOOD signals are masked during every OTF-VID Transition and they are re-activated with a 16 clock cycle delay to prevent from false triggering.

When changing dynamically the regulated voltage (OTF-VID), the system needs to charge or discharge the output capacitor accordingly. This means that an extra-current $I_{OTF-VID}$ needs to be delivered (especially when increasing the output regulated voltage) and it must be considered when setting the over current threshold of both the sections. This current results:

$$I_{OTF-VID} = C_{OUT} \cdot \frac{dV_{OUT}}{dT_{VID}}$$

where dV_{OUT} / dT_{VID} depends on the operative mode (3mV/μsec. in SVI or externally driven in PVI).

Overcoming the OC threshold during the dynamic VID causes the device latch and disable.

Dynamic VID transition is managed in different ways according to the device operative mode:

- PVI mode.

L6717 checks for VID code modifications (See Figure 11) on the rising-edge of an internal additional OTFVID-clock and waits for a confirmation on the following falling edge. Once the new code is stable, on the next rising edge, the reference starts stepping up or down in LSB increments every two OTFVID-clock cycle until the new VID code is reached. During the transition, VID code changes are ignored; the device re-starts monitoring VID after the transition has finished on the next rising-edge available. OTFVID-clock frequency (F_{OTFVID}) is 500 kHz.

If the new VID code is more than 1 LSB different from the previous, the device will execute the transition stepping the reference with the OTFVID-clock frequency F_{OTFVID}

until the new code has reached. The output voltage rate of change will be of $12.5 \text{ mV} / 4 \mu\text{sec.} = 3.125 \text{ mV}/\mu\text{sec.}$

Figure 11. PVI mode - on-the-fly VID transitions

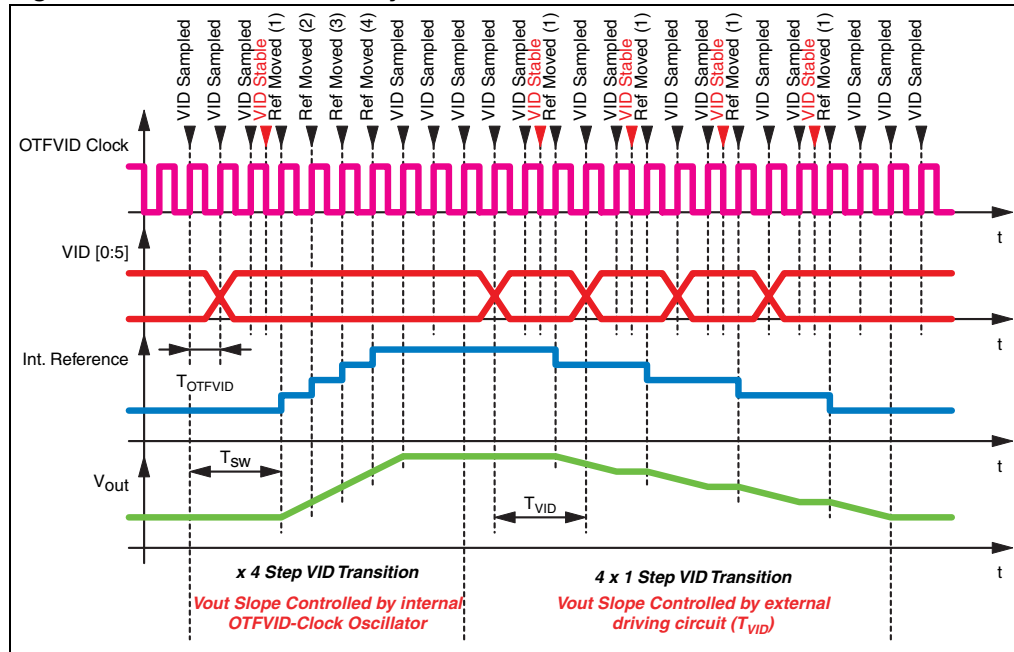

- SVI mode.

As soon as the controller receives a new valid command to set the VID level for one (or both) of the two sections, the reference of the involved section steps up or down according to the target-VID with a $3 \text{ mV}/\mu\text{sec.}$ slope (Typ). until the new VID code is reached.

If a new valid command is issued during the transition, the device updates the target-VID level and performs the on-the-fly transition up to the new code.

Pre-PWROK Metal-VID OTF-VID are not managed in this case because the *Pre-PWROK Metal VID* are stored after EN is asserted.

- V_FIX mode.

L6717 checks for SVC/SVD modifications and, once the new code is stable, it steps the reference of both sections up or down according to the target-VID with a $3 \text{ mV}/\mu\text{sec.}$ slope (Typ). until the new VID code is reached.

OV, UV and PWRGOOD are masked during the transition and re-activated with a 16 clock cycle delay after the end of the transition to prevent from false triggering.

7.8 Soft-start

L6717 implements a soft-start to smoothly charge the output filter avoiding high in-rush currents to be required to the input power supply. In SVI mode, soft-start time is intended as the time required by the device to set the output voltages to the *Pre-PWROK Metal VID*. During this phase, the device increases the reference of the enabled section(s) from zero up to the programmed reference in closed loop regulation. Soft-start is implemented only when VCC is above UVLO threshold and the EN pin is set free. See [Section 5](#) for details about the SVI interface and how SVC/SVD are interpreted in this phase.

At the end of the digital soft-start, PWRGOOD signal is set free.

Protections are active during this phase as follow:

- Undervoltage is enabled when the reference voltage reaches 0.5 V.
- Overvoltage is always enabled according to the programmed threshold (by R_{OVP}).
- FB disconnection is enabled.

Reference is increased with fixed dV/dt ; Soft-start time depends on the programmed voltage as follow:

$$T_{SS}[\text{ms}] = \text{Target_VID} \cdot 2.56$$

Figure 12. System start-up: SVI (left) and PVI (right)

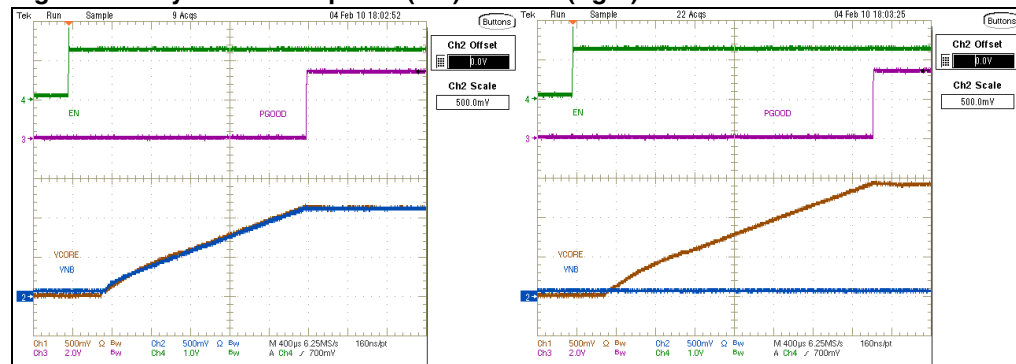

7.8.1 LS-Less Start-up

In order to avoid any kind of negative undershoot on the load side during start-up, L6717 performs a special sequence in enabling the drivers for both sections: during the soft-start phase, the LS MOSFET is kept OFF (PWMx set to HiZ and ENDRV = 0) until the first PWM pulse. After the first PWM pulse, the PWMx outputs switches between logic “0” and logic “1” and ENDRV are set to logic “1”.

This particular sequence avoids the dangerous negative spike on the output voltage that can happen if starting over a pre-biased output especially when exiting from a CORE-OFF state.

Low-side MOSFET turn-on is masked only from the control loop point of view: protections are still allowed to turn-ON the low-side MOSFET in case of over voltage if needed.

8 Output voltage monitoring and protections

L6717 monitors the regulated voltage of both sections through pin VSEN and NB_VSEN in order to manage OV, UV and PWRGOOD. The device shows different thresholds when in different operative conditions but the behavior in response to a protection event is still the same as described below.

Protections are active also during soft-start (See [Section 7.8](#)) while they are masked during OTF-VID transitions with an additional delay to avoid false triggering.

Table 20. L6717 protection at a glance

L6717	Section	
	CORE	North bridge
Overvoltage (OV)	SVI / PVI: +250mV above reference, programmable by power manager I ² C bus. I2CDIS = 3.3V: Programmable through SDA/OVP pin. V_FIX: Fixed to 1.8V. Action: IC Latch; LS=ON & PWMx = 0 (if applicable); Other section (SVI only): HiZ; FLT driven high.	
Undervoltage (UV)	VSEN, NB_VSEN = VID -400mV. Active after Ref > 500mV Action: IC latch; both sections HiZ; FLT driven high.	
PWRGOOD	PWRGOOD is the logic AND between internal CORE and NB PGOOD in SVI mode while is the CORE section PGOOD in PVI mode. Each PGOOD is set to zero when the related voltage falls below the programmed reference -250mV. Action: Section(s) continue switching, PWRGOOD driven low.	
VSEN, NB_VSEN disconnection	Set when VSEN > CS1N +600mV. Action: UV-Like	Set when VSEN > NB_CSN +600mV. Action: UV-Like (SVI only)
FBG, NB_FBG disconnection	Internal comparator across the opamp to recover from GND losses. Action: UV-Like	
Over Current (OC)	Current monitor across inductor DCR. Dual protection, per-phase and average. Action: UV-Like	Current monitor across inductor DCR. Constant current. Action: UV-Like
On-the-fly VID	Protections masked with the exception of OC with additional 16 clock delay to prevent from false triggering (both SVI and PVI).	

8.1 Programmable overvoltage (I2DIS = 3.3 V)

When power manager I²C is disabled, L6717 provides the possibility to adjust OV threshold (common for both sections) through the SDA/OVP pin. Connecting the pin to the center tap of a voltage divider from 3.3 V to SGND, the OVP threshold becomes the voltage present at the pin.

The OVP threshold results:

$$OVP_{TH} = 3.3 \cdot \frac{R_{OVPL}}{R_{OVPH} + R_{OVPL}}$$

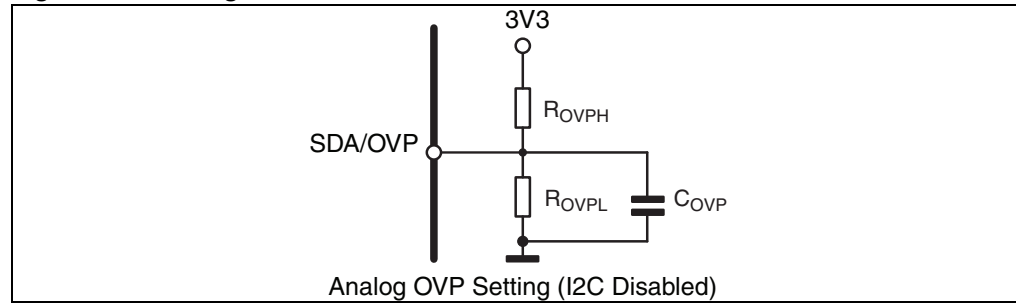
Figure 13. Analog OVP threshold

When the voltage sensed by VSEN and/or NB_VSEN overcomes the OV threshold, the controller:

- Permanently sets the PWM of the involved section to zero keeping ENDRV of that section high in order to keep all the low-side MOSFETs on to protect the load of the section in OV condition.
- Permanently sets the PWM of the non-involved section to HiZ while keeping ENDRV of the non-involved section low in order to realize an HiZ condition of the non-involved section.
- Drives the OSC/ FLT pin high.
- Power supply or EN pin cycling is required to restart operations.

Filter OVP pin with 1nF(typ) to SGND.

8.2 Feedback disconnection

L6717 provides both CORE and NB sections with FB disconnection protection. This feature acts in order to stop the device from regulating dangerous voltages in case the remote sense connections are left floating. The protection is available for both the sections and operates for both the positive and negative sense.

According to [Figure 14](#), the protection works as follow:

- CORE section:

Positive sense is performed monitoring the CORE output voltage through both VSEN and CS1N. As soon as CS1N is more than 600 mV higher than VSEN, the device latches in HiZ. FLT pin is driven high. A 30 μ A pull-down current on the VSEN forces the device to detect this fault condition.

Negative sense is performed monitoring the internal OpAmp used to recover the GND losses by comparing its output and the internal reference generated by the DAC. As soon as the difference between the output and the input of this OpAmp is higher than 500 mV, the device latches in HiZ. FLT pin is driven high.

- NB section (SVI only)

Positive sense is performed monitoring the NB output voltage through both NB_VSEN and NB_CSN. As soon as NB_CSN is more than 600 mV higher than NB_VSEN, the device latches in HiZ. FLT pin is driven high. A 30 μ A pull-down current on the NB_VSEN forces the device to detect this fault condition.

Negative sense is performed monitoring the internal OpAmp used to recover the GND losses by comparing its output and the internal reference generated by the DAC. As

soon as the difference between the output and the input of this OpAmp is higher than 500mV, the device latches in HiZ. FLT pin is driven high.

To recover from a latch condition, cycle VCC or EN.

Figure 14. FB disconnection protection

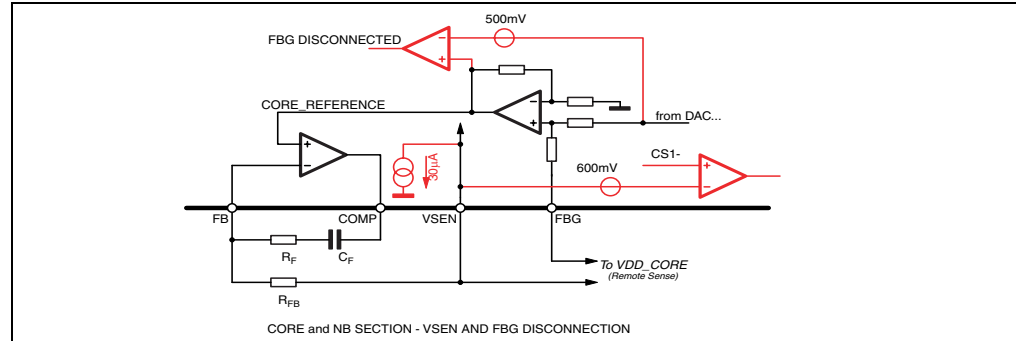

8.3 PWRGOOD

It is an open-drain signal set free after the soft-start sequence has finished; it is the logic AND between the internal CORE and NB PGOOD (or just the CORE PGOOD in PVI mode). It is pulled low when the output voltage of one of the two sections drops 250 mV below the programmed voltage. It is masked during on-the-fly VID transitions as well as when the CORE section is set to OFF (from SVI bus) while the NB section is still operative.

8.4 Overcurrent

The overcurrent threshold has to be programmed to a safe value, in order to be sure that each section doesn't enter OC during normal operation of the device. This value must take into consideration also the extra current needed during the OTF-VID transition ($I_{OTF-VID}$) and the process spread and temperature variations of the sensing elements (Inductor DCR).

Moreover, since also the internal threshold spreads, the design has to consider the minimum/maximum values of the threshold. Considering the reading method, the two sections will show different behaviors in OC.

8.4.1 CORE section

L6717 performs two different OC protections for the CORE section: it monitors both the total current and the per-phase current and allows to set an OC threshold for both.

- Per-phase OC.
Maximum information current per-phase (I_{INFOX}) is internally limited to 35 μ A. This end-of-scale current (I_{OC_TH}) is compared with the information current generated for each phase (I_{INFOX}). If the current information for the single phase exceeded the end-of-scale current (i.e. if $I_{INFOX} > I_{OC_TH}$), the device will turn-on the LS MOSFET until the threshold is re-crossed (i.e. until $I_{INFOX} < I_{OC_TH}$).
- Total current OC.
ILIM pin allows to define a maximum total output current for the system (I_{OC_TOT}). I_{LIM} current is sourced from the ILIM pin (not altered by DRP_ADJ command). By connecting a resistor R_{ILIM} to SGND, a load indicator with 2.5 V (V_{OC_TOT}) end-of-

scale can be implemented. When the voltage present at the ILIM pin crosses V_{OC_TOT} , the device detects an OC and immediately latches with all the MOSFETs of all the sections OFF (HiZ).

Typical design considers the intervention of the total current OC before the per-phase OC, leaving this last one as an extreme-protection in case of hardware failures in the external components. Typical design flow is the following:

- Define the maximum total output current (I_{OC_TOT}) according to system requirements
- Design per-phase OC and R_G resistor in order to have $I_{INFOx} = I_{OC_TH}$ (35 μ A) when I_{OUT} is about 10% higher than the I_{OC_TOT} current. It results:

$$R_G = \frac{(1.1 \cdot I_{OC_TOT}) \cdot DCR}{N \cdot I_{OC_TH}}$$

where N is the number of phases and DCR the DC resistance of the inductors. R_G should be designed in worst-case conditions.

- Design the total current OC and R_{ILIM} in order to have the ILIM pin voltage to V_{OC_TOT} at the desired maximum current I_{OC_TOT} . It results:

$$R_{ILIM} = \frac{V_{OC_TOT} \cdot R_G}{I_{OC_TOT} \cdot DCR} \quad \left(I_{LIM} = \frac{DCR}{R_G} \cdot I_{OUT} \right)$$

where V_{OC_TOT} is typically 2.5V and I_{OC_TOT} is the total current OC threshold desired.

- Adjust the defined values according to bench-test of the application.
- An additional capacitor in parallel to R_{ILIM} can be considered to add a delay in the protection intervention.

Note: *What previously listed is the typical design flow. Custom design and specifications may require different settings and ratios between the per-phase OC threshold and the Total Current OC threshold. Applications with huge ripple across inductors may be required to set per-phase OC to values different than 110%: design flow should be modified accordingly.*

Note: *DRP_ADJ command from power manager I²C does not alter the current information used for per-phase OC and total current OC.*

8.4.2 NB section

NB section performs per-phase over current: its maximum information current (I_{INFO_NB}) is internally limited to I_{OCTH_NB} (35 μ A typ). If the current information for the NB phase exceeds the end-of-scale current (i.e. if $I_{INFO_NB} > I_{OCTH_NB}$), the device will turn-on the low-side MOSFET, also skipping clock cycles, until the threshold is re-crossed (i.e. until $I_{INFO_NB} < I_{OCTH_NB}$).

After exiting the OC condition, the low-side MOSFET is turned off and the high-side is turned on with a duty cycle driven by the PWM comparator.

Design R_{G_NB} resistor in order to have $I_{DROOP_NB} = I_{OCTH_NB}$ (35 μ A) at the I_{OC_NBmax} current.

It results:

$$R_{G_NB} = \frac{I_{OC_NBmax} \cdot DCF}{I_{OCTH_NB}}$$

Note: DRP_ADJ command from power manager I²C does not alter the current information used for per-phase OC.

9 Main oscillator

The controller embeds a dual-oscillator: one section is used for the CORE and it is a multi-phase programmable oscillator managing equal phase-shift among all phases and the other section is used for the NB section. Phase-shift between the CORE and NB ramps is automatically adjusted according to the CORE phase # programmed.

The internal oscillator generates the triangular waveform for the PWM charging and discharging with a constant current an internal capacitor. The switching frequency for each channel, F_{SW} , is internally fixed at 200 kHz: the resulting switching frequency for the CORE section at the load side results in being multiplied by N (number of configured phases).

The current delivered to the oscillator is typically 20 μA (corresponding to the free running frequency $F_{SW}=200$ kHz) and it may be varied using an external resistor (R_{OSC}) typically connected between the OSC pin and SGND. Since the OSC pin is fixed at 1.240 V, the frequency is varied proportionally to the current sunk from the pin considering the internal gain of 9.1 kHz/ μA (See [Figure 15](#)).

Connecting R_{OSC} to SGND the frequency is increased (current is sunk by the pin), according to the following relationships:

$$F_{SW} = 200\text{kHz} + \frac{1.240\text{V}}{R_{OSC}} \cdot 9.1 \frac{\text{kHz}}{\mu\text{A}}$$

Connecting R_{OSC} to a positive voltage (recommended 3.3 V rail) the frequency is reduced (current is injected into the pin), according to the following relationships:

$$F_{SW} = 200\text{kHz} - \frac{+V - 1.240}{R_{OSC}} \cdot 9.1 \frac{\text{kHz}}{\mu\text{A}}$$

where +V is the positive voltage which the R_{OSC} resistor is connected.

Figure 15. R_{OSC} vs. switching frequency

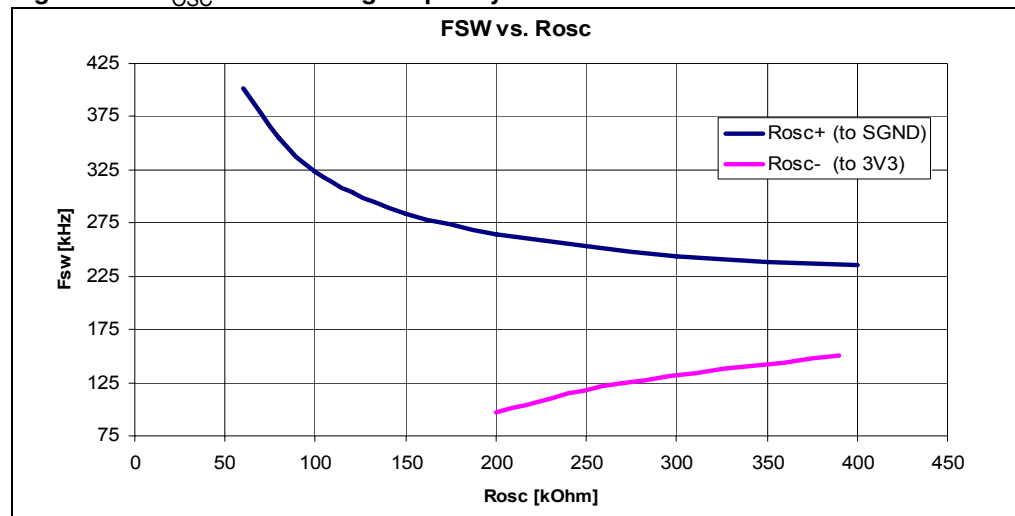

10 High current embedded drivers

L6717 provides high-current driving control for CORE and NB sections. The driver for the high-side MOSFET use BOOTx pin for supply and PHASEx pin for return. The driver for the low-side MOSFET use the VCCDR pin for supply and GND pin for return.

The embedded driver embodies an anti-shoot-through and adaptive dead-time control to minimize low-side body diode conduction time maintaining good efficiency saving the use of Schottky diodes: when the high-side MOSFET turns off, the voltage on its source begins to fall; when the voltage reaches about 2 V, the low-side MOSFET gate drive voltage is suddenly applied. When the low-side MOSFET turns off, the voltage at LGATE pin is sensed. When it drops below about 1 V, the high-side MOSFET gate drive voltage is suddenly applied. If the current flowing in the inductor is negative, the source of high-side MOSFET will never drop. To allow the low-side MOSFET to turn-on even in this case, a watchdog controller is enabled: if the source of the High-Side MOSFET doesn't drop, the low-side MOSFET is switched on so allowing the negative current of the inductor to recirculate. This mechanism allows the system to regulate even if the current is negative.

10.1 Boot capacitor design

Bootstrap capacitor needs to be designed in order to show a negligible discharge due to the high-side MOSFET turn-on. In fact it must give a stable voltage supply to the high-side driver during the MOSFET turn-on also minimizing the power dissipated by the embedded boot diode. [Figure 16](#) gives some guidelines on how to select the capacitance value for the bootstrap according to the desired discharge and depending on the selected MOSFET.

To prevent bootstrap capacitor to extra-charge as a consequence of large negative spikes, an external series resistance R_{BOOT} (in the range of few ohms) may be required in series to BOOT pin.

Figure 16. Bootstrap capacitor design

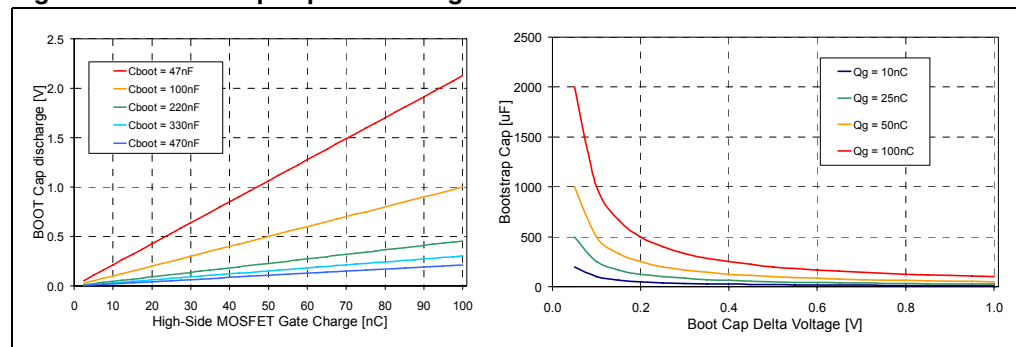

10.2 Power dissipation

It is important to consider the power that the device is going to dissipate in driving the external MOSFETs in order to avoid overcoming the maximum junction operative temperature.

Two main terms contribute in the device power dissipation: bias power and drivers' power.

- Device power (P_{DC}) depends on the static consumption of the device through the supply pins and it is simply quantifiable as follow:

$$P_{DC} = V_{CC} \cdot I_{CC} + V_{VCCDR} \cdot I_{VCCDR}$$

- Drivers' power is the power needed by the driver to continuously switch ON and OFF the external MOSFETs; it is a function of the switching frequency and total gate charge of the selected MOSFETs. It can be quantified considering that the total power P_{SW} dissipated to switch the MOSFETs dissipated by three main factors: external gate resistance (when present), intrinsic MOSFET resistance and intrinsic driver resistance. This last term is the important one to be determined to calculate the device power dissipation.

The total power dissipated to switch the MOSFETs for each phase featuring embedded driver results:

$$P_{SWx} = F_{SW} \cdot (Q_{GLSx} \cdot V_{CCDR} + Q_{GHSx} \cdot V_{BOOTx})$$

Where Q_{GHSx} is the total gate charge of the HS MOSFETs and Q_{GLSx} is the total gate charge of the LS MOSFETs for both CORE and NB sections (only Phase1 and Phase2 for CORE section); V_{BOOTx} is the driving voltage for the HSx MOSFETs.

11 System control loop compensation

The device embeds two separate and independent control loops for CORE and NB section. The control loop for NB section is a simple voltage-mode control loop with (optional) voltage positioning featured when DROOP pin is shorted with FB. The control loop for the CORE section also features a current-sharing loop to equalize the current carried by each of the configured phases.

The CORE control system can be modeled with an equivalent single-phase converter whose only difference is the equivalent inductor L/N (where each phase has an L inductor and N is the number of the configured phases). See [Figure 17](#).

Figure 17. Equivalent control loop for NB and CORE sections

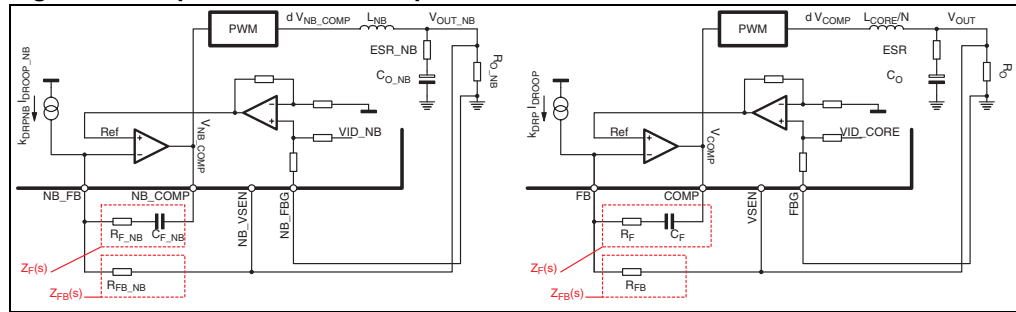

This means that the same analysis can be used for both the sections with the only exception of the different equivalent inductor value ($L=L_{NB}$ for NB section and $L=L_{CORE}/N$ for the CORE section) and the current reading gain (DCR/R_{G_NB} for NB Section and DCR/R_G for the CORE section).

The control loop gain results (obtained opening the loop after the COMP pin):

$$G_{LOOP}(s) = \frac{PWM \cdot Z_F(s) \cdot (R_{LL} + Z_P(s))}{[Z_P(s) + Z_L(s)] \cdot \left[\frac{Z_F(s)}{A(s)} + \left(1 + \frac{1}{A(s)}\right) \cdot R_{FB} \right]}$$

Where:

- R_{LL} is the equivalent output resistance determined by the droop function;
- $Z_P(s)$ is the impedance resulting by the parallel of the output capacitor (and its ESR) and the applied load R_O ;
- $Z_F(s)$ is the compensation network impedance;
- $Z_L(s)$ is the equivalent inductor impedance;
- $A(s)$ is the error amplifier gain;
- $PWM = \frac{3}{5} \cdot \frac{V_{IN}}{\Delta V_{OSC}}$ is the PWM transfer function.

The control loop gain for each section is designed in order to obtain a high DC gain to minimize static error and to cross the 0dB axes with a constant -20 dB/Dec. slope with the desired crossover frequency ω_T . Neglecting the effect of $Z_F(s)$, the transfer function has one zero and two poles; both the poles are fixed once the output filter is designed (LC filter resonance ω_{LC}) and the zero (ω_{ESR}) is fixed by ESR and the droop resistance.

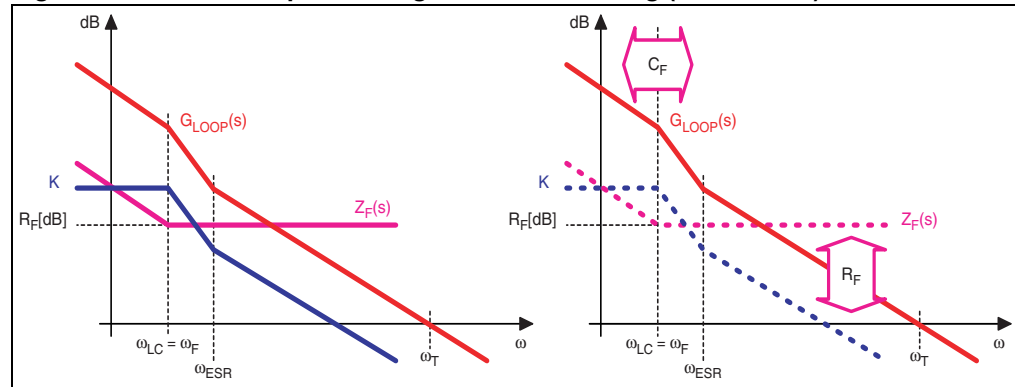
Figure 18. Control loop bode diagram and fine tuning (not in scale)

To obtain the desired shape an R_F - C_F series network is considered for the $Z_F(s)$ implementation. A zero at $\omega_F=1/R_FC_F$ is then introduced together with an integrator. This integrator minimizes the static error while placing the zero ω_F in correspondence with the L-C resonance assures a simple -20 dB/Dec. shape of the gain.

In fact, considering the usual value for the output filter, the LC resonance results to be at frequency lower than the above reported zero.

Compensation network can be simply designed placing $\omega_F=\omega_{LC}$ and imposing the cross-over frequency ω_T as desired obtaining (always considering that ω_T might be not higher than 1/10th of the switching frequency F_{SW}):

$$R_F = \frac{R_{FB} \cdot \Delta V_{OSC}}{V_{IN}} \cdot \frac{3}{5} \cdot \omega_T \cdot \frac{L}{N \cdot (R_{LL} + ESR)}$$

$$C_F = \frac{\sqrt{C_O \cdot L}}{R_F}$$

11.1 Compensation network guidelines

The compensation network design assures to having system response according to the cross-over frequency selected and to the output filter considered: it is anyway possible to further fine-tune the compensation network modifying the bandwidth in order to get the best response of the system as follow (See [Figure 18](#)):

- Increase R_F to increase the system bandwidth accordingly;
- Decrease R_F to decrease the system bandwidth accordingly;
- Increase C_F to move ω_F to low frequencies increasing as a consequence the system phase margin.

Having the fastest compensation network gives not the confidence to satisfy the requirements of the load: the inductor still limits the maximum di/dt that the system can afford. In fact, when a load transient is applied, the best that the controller can do is to “saturate” the duty cycle to its maximum (d_{MAX}) or minimum (0) value. The output voltage dV/dt is then limited by the inductor charge / discharge time and by the output capacitance. In particular, the most limiting transition corresponds to the load removal since the inductor results being discharged only by V_{OUT} (while it is charged by $d_{MAX}V_{IN}-V_{OUT}$ during a load appliance).

12 LTB Technology®

LTB Technology® further enhances the performances of dual-edge asynchronous systems by reducing the system latencies and immediately turning ON all the phases to provide the correct amount of energy to the load. By properly designing the LTB network as well as the LTB gain, the undershoot and the ring-back can be minimized also optimizing the output capacitors count. LTB Technology® applies only to the CORE section.

LTB Technology® monitors the output voltage through a dedicated pin detecting Load-Transients with selected dV/dt , it cancels the interleaved phase-shift, turning-on simultaneously all phases. It then implements a parallel, independent loop that reacts to load-transients bypassing E/A latencies.

LTB Technology® control loop is reported in [Figure 19](#).

Figure 19. LTB Technology® control loop (CORE section)

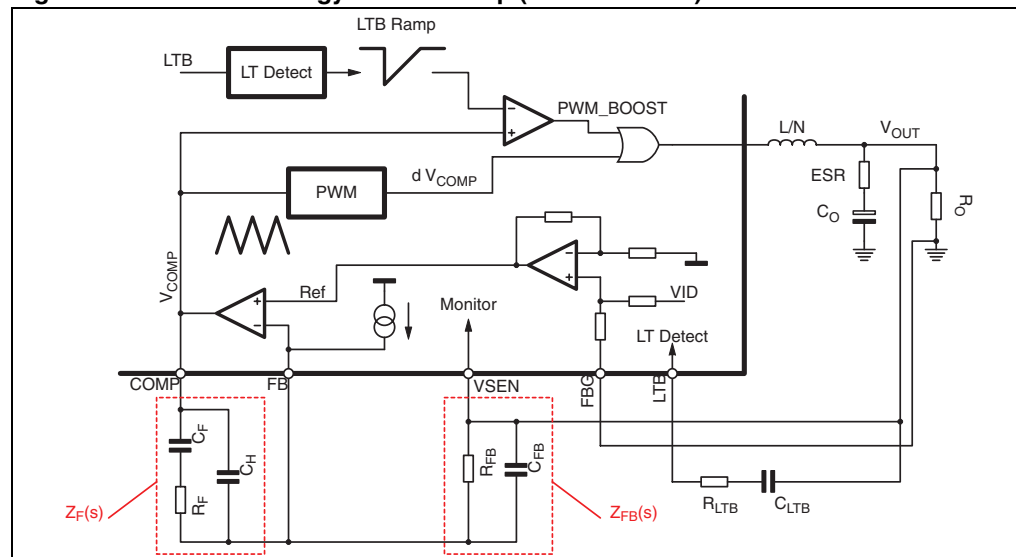

The LTB detector is able to detect output load transients by coupling the output voltage through an $R_{LTB} - C_{LTB}$ network. After detecting a load transient, the LTB Ramp is reset and then compared with the COMP pin level. The resulting duty-cycle programmed is then ORed with the PWMx signal of each phase by-passing the main control loop. All the phases will then be turned-on together and the EA latencies results bypassed as well.

Sensitivity of the load transient detector can be programmed in order to control precisely both the undershoot and the ring-back.

$R_{LTB} - C_{LTB}$ is designed according to the output voltage deviation dV_{OUT} which is desired the controller to be sensitive as follow:

$$R_{LTB} = \frac{dV_{OUT}}{25\mu A} \quad C_{LTB} = \frac{1}{2\pi \cdot N \cdot R_{LTB} \cdot F_{SW}}$$

LTB Technology® design tips.

- Decrease R_{LTB} to increase the system sensitivity making the system sensitive to smaller dV_{OUT} .
- Increase C_{LTB} to increase the system sensitivity making the system sensitive to higher dV/dt .

13 Layout guidelines

Layout is one of the most important things to consider when designing high current applications. A good layout solution can generate a benefit in lowering power dissipation on the power paths, reducing radiation and a proper connection between signal and power ground can optimize the performance of the control loops.

Two kind of critical components and connections have to be considered when laying-out a VRM based on L6717: power components and connections and small signal components connections.

13.1 Power components and connections

These are the components and connections where switching and high continuous current flows from the input to the load. The first priority when placing components has to be reserved to this power section, minimizing the length of each connection and loop as much as possible. To minimize noise and voltage spikes (EMI and losses) these interconnections must be a part of a power plane and anyway realized by wide and thick copper traces: loop must be anyway minimized. The critical components, i.e. the power transistors, must be close one to the other. The use of multi-layer printed circuit board is recommended.

Traces between the driver section and the MOSFETs should be wide to minimize the inductance of the trace so minimizing ringing in the driving signals. Moreover, VIAs count needs to be minimized to reduce the related parasitic effect.

Locate the bypass capacitor (VCC, VCCDR and BOOT capacitors) close to the device with the shortest possible loop and use wide copper traces to minimize parasitic inductance.

Systems that do not use Schottky diodes in parallel to the low-side MOSFET might show big negative spikes on the phase pin. This spike can be limited as well as the positive spike but it causes the bootstrap capacitor to be over-charged. This extra-charge can cause, in the worst case condition of maximum input voltage and during particular transients, that boot-to-phase voltage overcomes the abs.max.ratings also causing device failures. It is then suggested in this cases to limit this extra-charge by adding a small resistor R_{BOOT} in series to the boot capacitor or the boot diode. The use of R_{BOOT} also contributes in the limitation of the spike present on the BOOT pin.

Figure 20. Driver turn-on and turn-off paths

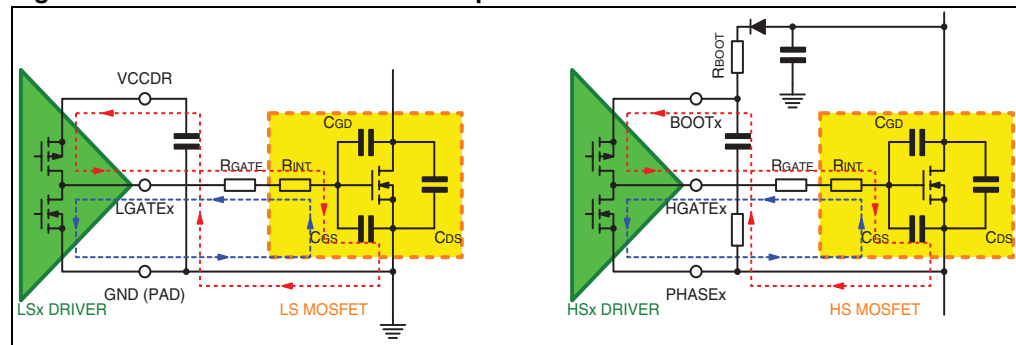

For heat dissipation, place copper area under the IC. This copper area must be connected with internal copper layers through several VIAs to improve the thermal conductivity. The combination of copper pad, copper plane and VIAs under the controller allows the device to reach its best thermal performances.

13.2 Small signal components and connections

These are small signal components and connections to critical nodes of the application as well as bypass capacitors for the device supply. Locate the bypass capacitor close to the device and refer sensible components such as frequency set-up resistor R_{OSC} , offset resistor and OVP resistor R_{OVP} to SGND (when applicable). Star grounding is suggested: use the device exposed PAD as a connection point.

VSEN pin filtered vs. SGND helps in reducing noise injection into device and EN pin filtered vs. SGND helps in reducing false trip due to coupled noise: take care in routing driving net for this pin in order to minimize coupled noise.

Remote buffer connection must be routed as parallel nets from the FBG/FBR pins to the load in order to avoid the pick-up of any common mode noise. Connecting these pins in points far from the load will cause a non-optimum load regulation, increasing output tolerance.

Locate current reading components close to the device. The PCB traces connecting the reading point must use dedicated nets, routed as parallel traces in order to avoid the pick-up of any common mode noise. It's also important to avoid any offset in the measurement and, to get a better precision, to connect the traces as close as possible to the sensing elements. Symmetrical layout is also suggested. Small filtering capacitor can be added, near the controller, between V_{OUT} and SGND, on the CSxN line when reading across inductor to allow higher layout flexibility.

14 VFQFPN48 mechanical data and package dimensions

In order to meet environmental requirements, ST offers these devices in different grades of ECOPACK® packages, depending on their level of environmental compliance. ECOPACK® specifications, grade definitions and product status are available at: www.st.com. ECOPACK is an ST trademark.

Figure 21. VFQFPN48 mechanical data and package dimensions

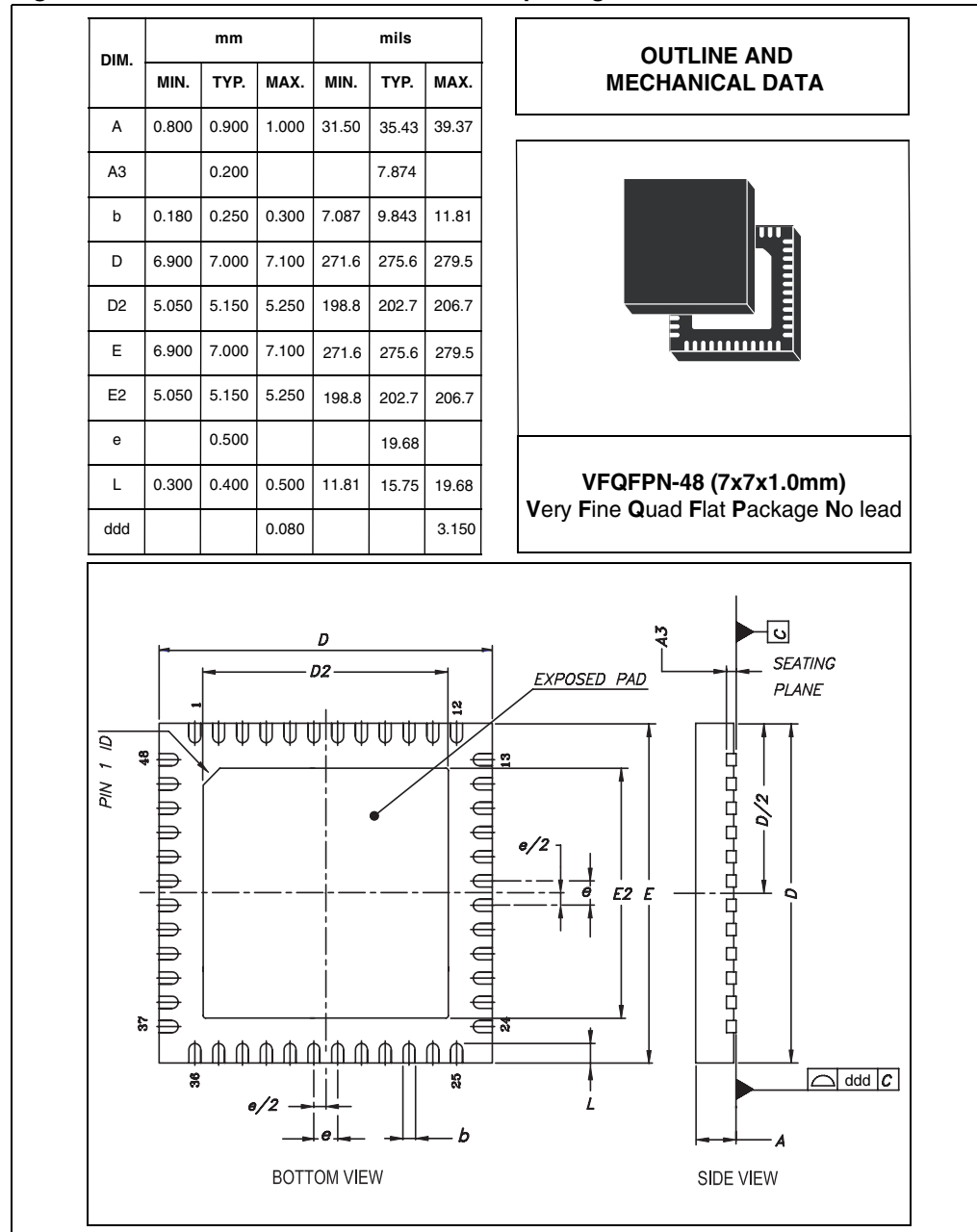

15 Revision history

Table 21. Document revision history

Date	Revision	Changes
29-Mar-2010	1	Initial release.

Please Read Carefully:

Information in this document is provided solely in connection with ST products. STMicroelectronics NV and its subsidiaries ("ST") reserve the right to make changes, corrections, modifications or improvements, to this document, and the products and services described herein at any time, without notice.

All ST products are sold pursuant to ST's terms and conditions of sale.

Purchasers are solely responsible for the choice, selection and use of the ST products and services described herein, and ST assumes no liability whatsoever relating to the choice, selection or use of the ST products and services described herein.

No license, express or implied, by estoppel or otherwise, to any intellectual property rights is granted under this document. If any part of this document refers to any third party products or services it shall not be deemed a license grant by ST for the use of such third party products or services, or any intellectual property contained therein or considered as a warranty covering the use in any manner whatsoever of such third party products or services or any intellectual property contained therein.

UNLESS OTHERWISE SET FORTH IN ST'S TERMS AND CONDITIONS OF SALE ST DISCLAIMS ANY EXPRESS OR IMPLIED WARRANTY WITH RESPECT TO THE USE AND/OR SALE OF ST PRODUCTS INCLUDING WITHOUT LIMITATION IMPLIED WARRANTIES OF MERCHANTABILITY, FITNESS FOR A PARTICULAR PURPOSE (AND THEIR EQUIVALENTS UNDER THE LAWS OF ANY JURISDICTION), OR INFRINGEMENT OF ANY PATENT, COPYRIGHT OR OTHER INTELLECTUAL PROPERTY RIGHT.

UNLESS EXPRESSLY APPROVED IN WRITING BY AN AUTHORIZED ST REPRESENTATIVE, ST PRODUCTS ARE NOT RECOMMENDED, AUTHORIZED OR WARRANTED FOR USE IN MILITARY, AIR CRAFT, SPACE, LIFE SAVING, OR LIFE SUSTAINING APPLICATIONS, NOR IN PRODUCTS OR SYSTEMS WHERE FAILURE OR MALFUNCTION MAY RESULT IN PERSONAL INJURY, DEATH, OR SEVERE PROPERTY OR ENVIRONMENTAL DAMAGE. ST PRODUCTS WHICH ARE NOT SPECIFIED AS "AUTOMOTIVE GRADE" MAY ONLY BE USED IN AUTOMOTIVE APPLICATIONS AT USER'S OWN RISK.

Resale of ST products with provisions different from the statements and/or technical features set forth in this document shall immediately void any warranty granted by ST for the ST product or service described herein and shall not create or extend in any manner whatsoever, any liability of ST.

ST and the ST logo are trademarks or registered trademarks of ST in various countries.

Information in this document supersedes and replaces all information previously supplied.

The ST logo is a registered trademark of STMicroelectronics. All other names are the property of their respective owners.

© 2010 STMicroelectronics - All rights reserved

STMicroelectronics group of companies

Australia - Belgium - Brazil - Canada - China - Czech Republic - Finland - France - Germany - Hong Kong - India - Israel - Italy - Japan - Malaysia - Malta - Morocco - Philippines - Singapore - Spain - Sweden - Switzerland - United Kingdom - United States of America

www.st.com