

## Features

- Low Pin Count (LPC) BIOS Device
- Functions as Firmware Hub for Intel 8XX, E7XXX and E8XXX Chipsets
- 8M Bits of Flash Memory for Platform Code/Data Storage
  - Uniform, 64-Kbyte Memory Sectors
  - Automated Byte-program and Sector-erase Operations
- Two Configurable Interfaces
  - Firmware Hub (FWH) Interface for In-System Operation
  - Address/Address Multiplexed (A/A Mux) Interface for Programming during Manufacturing
- Firmware Hub Hardware Interface Mode
  - 5-signal Communication Interface Supporting x8 Reads and Writes
  - Read and Write Protection for Each Sector Using Software-controlled Registers
  - Two Hardware Write-protect Pins: One for the Top Boot Sector, One for All Other Sectors
  - Five General-purpose Inputs, GPIs, for Platform Design Flexibility
  - Operates with 33 MHz PCI Clock and 3.3V I/O
- Address/Address Multiplexed (A/A Mux) Interface
  - 11-pin Multiplexed Address and 8-pin Data Interface
  - Supports Fast On-board or Out-of-system Programming
- Power Supply Specifications
  - $V_{CC}$ : 3.3V  $\pm$  0.3V
  - $V_{PP}$ : 3.3V and 12V for Fast Programming
- Industry-standard Packages
  - (40-lead TSOP or 32-lead PLCC)
- Green (Pb/Halide-free) Packaging Option

## 1. Description

The AT49LW080 is a Flash memory device designed to be compatible with the Intel 82802AC and the Intel 82802AB Firmware Hub (FWH) devices for PC-Bios Application. A feature of the AT49LW080 is the nonvolatile memory core. The high-performance memory is arranged in sixteen 64-Kbyte sectors (see [page 13](#)).

The AT49LW080 supports two hardware interfaces: Firmware Hub (FWH) for in-system operation and Address/Address Multiplexed (A/A Mux) for programming during manufacturing. The IC (Interface Configuration) pin of the device provides the control between the interfaces. The interface mode needs to be selected prior to power-up or before return from reset ( $\overline{RST}$  or  $\overline{INIT}$  low to high transition).

An internal Command User Interface (CUI) serves as the control center between the two device interfaces (FWH and A/A Mux) and internal operation of the nonvolatile memory. A valid command sequence written to the CUI initiates device automation.

Specifically designed for 3V systems, the AT49LW080 supports read operations at 3.3V and sector erase and program operations at 3.3V and 12V  $V_{PP}$ . The 12V  $V_{PP}$  option renders the fastest program performance which will increase factory throughput, but is not recommended for standard in-system FWH operation in the platform. With the 3.3V  $V_{PP}$  option,  $V_{CC}$  and  $V_{PP}$  should be tied together for a simple, low-power 3V design. In addition to the voltage flexibility, the dedicated VPP pin gives complete



## 8-megabit Firmware Hub Flash Memory

### AT49LW080

1966G-FLASH-3/05



data protection when  $V_{PP} \leq V_{PPLK}$ . Internal  $V_{PP}$  detection circuitry automatically configures the device for sector erase and program operations. Note that, while current for 12V programming will be drawn from  $V_{PP}$ , 3.3V programming board solutions should design such that  $V_{PP}$  draws from the same supply as  $V_{CC}$ , and should assume that full programming current may be drawn from either pin.

## 2. Pin Configurations

### 2.1 32-lead PLCC Top View

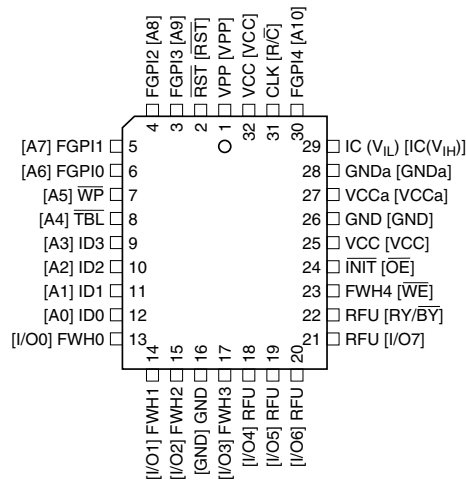

[ ] Designates A/A Mux Mode

### 2.2 32-lead TSOP Top View

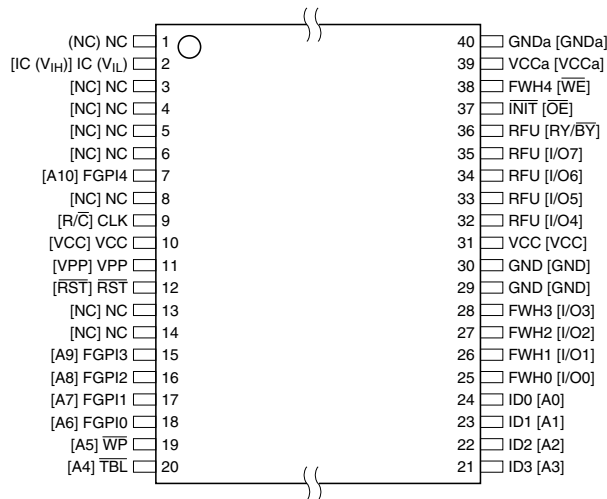

[ ] Designates A/A Mux Mode

### 2.3 Firmware Hub Interface

The Firmware Hub (FWH) interface is designed to work with the I/O Controller Hub (ICH) during platform operation.

The FWH interface consists primarily of a five-signal communication interface used to control the operation of the device in a system environment. The buffers for this interface are PCI compliant. To ensure the effective delivery of security and manageability features, the FWH interface is the only way to get access to the full feature set of the device. The FWH interface is equipped to operate at 33 MHz, synchronous with the PCI bus.

### 2.4 Address/Address Multiplexed Interface

The A/A Mux interface is designed as a programming interface for OEMs to use during motherboard manufacturing or component pre-programming.

The A/A Mux refers to the multiplexed row and column addresses in this interface. This approach is required so that the device can be tested and programmed quickly with automated test equipment (ATE) and PROM programmers in the OEM's manufacturing flow. This interface also allows the device to have an efficient programming interface with potentially large future densities, while still fitting into a 32-pin package. Only basic reads, programming, and erase of the nonvolatile memory sectors can be performed through the A/A Mux interface. In this mode FWH features, security features and registers are unavailable. A row/column (R/C) pin determines which set of addresses "rows or columns" are latched.

## 3. Block Diagram

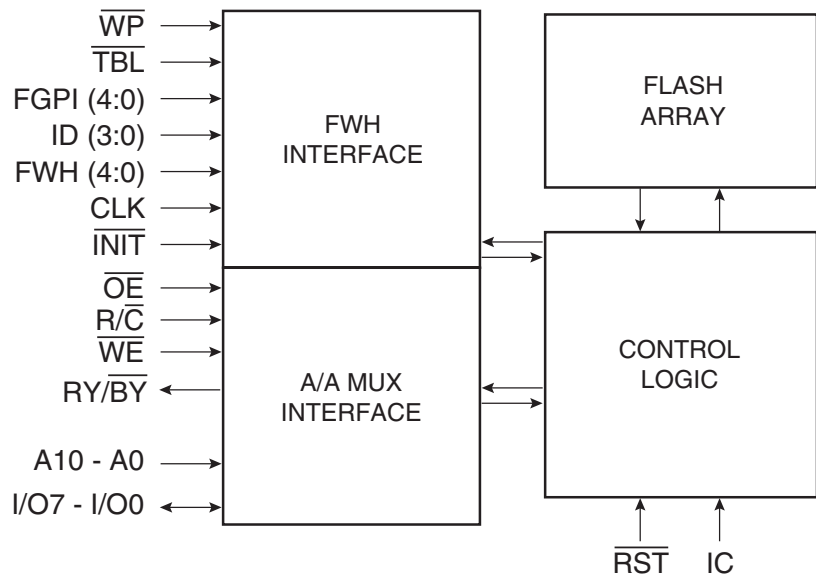

## 4. Pin Description

Table 4-1 details the usage of each of the device pins. Most of the pins have dual functionality, with functions in both the Firmware Hub and A/A Mux interfaces. A/A Mux functionality for pins is shown in **bold** in the description box for that pin. All pins are designed to be compliant with voltage of  $V_{CC} + 0.3V$  max, unless otherwise noted.

**Table 4-1.** Pin Description

Symbol	Type	Interface		Name and Function
		FWH	A/A Mux	
IC	INPUT	X	X	<b>INTERFACE CONFIGURATION PIN:</b> This pin determines which interface is operational. This pin is held high to enable the A/A Mux interface. This pin is held low to enable the FWH interface. This pin must be set at power-up or before return from reset and not changed during device operation. This pin is pulled down with an internal resistor, with value between 20 and 100 k $\Omega$ . With IC high (A/A Mux mode), this pin will exhibit a leakage current of approximately 200 $\mu$ A. This pin may be floated, which will select FWH mode.
$\overline{RST}$	INPUT	X	X	<b>INTERFACE RESET:</b> Valid for both A/A Mux and FWH interface operations. When driven low, $\overline{RST}$ inhibits write operations to provide data protection during power transitions, resets internal automation, and tri-states pins FWH [3:0] (in FWH interface mode). $\overline{RST}$ high enables normal operation. When exiting from reset, the device defaults to read array mode.
$\overline{INIT}$	INPUT	X		<b>PROCESSOR RESET:</b> This is a second reset pin for in-system use. This pin is internally combined with the $\overline{RST}$ pin. If this pin or $\overline{RST}$ is driven low, identical operation is exhibited. This signal is designed to be connected to the chipset INIT signal (Max voltage depends on the processor. Do not use 3.3V.) <b>A/A Mux = <math>\overline{OE}</math></b>
CLK	INPUT	X		<b>33 MHz CLOCK for FWH INTERFACE:</b> This input is the same as the PCI clock and adheres to the PCI specification. <b>A/A Mux = <math>R/\overline{C}</math></b>
FWH[3:0]	I/O	X		<b>FWH I/Os:</b> I/O Communication. <b>A/A Mux = <math>I/O[3:0]</math></b>
FWH4	INPUT	X		<b>FWH INPUT:</b> Input Communication. <b>A/A Mux = <math>\overline{WE}</math></b>
ID[3:0]	INPUT	X		<b>IDENTIFICATION INPUTS:</b> These four pins are part of the mechanism that allows multiple parts to be attached to the same bus. The strapping of these pins is used to identify the component. The boot device must have ID[3:0] = 0000 and it is recommended that all subsequent devices should use a sequential up-count strapping (i.e., 0001, 0010, 0011, etc.). These pins are pulled down with internal resistors, with values between 20 and 100 k $\Omega$ when in FWH mode. Any ID pins that are pulled high will exhibit a leakage current of approximately 200 $\mu$ A. Any pins intended to be low may be left to float. In a single FWH system, all may be left floating. <b>A/A Mux = <math>A[3:0]</math></b>
FGPI[4:0]	INPUT	X		<b>FWH GENERAL PURPOSE INPUTS:</b> These individual inputs can be used for additional board flexibility. The state of these pins can be read through FWH registers. These inputs should be at their desired state before the start of the PCI clock cycle during which the read is attempted, and should remain at the same level until the end of the read cycle. They may <i>only</i> be used for <b>3.3V</b> signals. Unused FGPI pins must <b>not</b> be floated. <b>A/A Mux = <math>A[10:6]</math></b>
$\overline{TBL}$	INPUT	X		<b>TOP SECTOR LOCK:</b> When low, prevents programming or sector erase to the highest addressable sector (15), regardless of the state of the lock registers $\overline{TBL}$ high disables hardware write protection for the top sector, though register-based protection still applies. The status of $\overline{TBL}$ does not affect the status of sector-locking registers. <b>A/A Mux = <math>A4</math></b>

**Table 4-1.** Pin Description (Continued)

Symbol	Type	Interface		Name and Function
		FWH	A/A Mux	
$\overline{WP}$	INPUT	X		<b>WRITE-PROTECT:</b> When low, prevents programming or sector erase to all but the highest addressable sectors (0 - 14), regardless of the state of the corresponding lock registers. $\overline{WP}$ -high disables hardware write protection for these sectors, though register-based protection still applies. The status of $\overline{TBL}$ does not affect the status of sector-locking registers. <b>A/A Mux = A5</b>
A0 - A10	INPUT		X	<b>LOW-ORDER ADDRESS INPUTS:</b> Inputs for low-order addresses during read and write operations. Addresses are internally latched during a write cycle. For the A/A Mux interface these addresses are latched by $R/\overline{C}$ and share the same pins as the high-order address inputs.
I/O0 - I/O7	I/O		X	<b>DATA INPUT/OUTPUTS:</b> These pins receive data and commands during write cycles and transmit data during memory array and identifier code read cycles. Data pins float to high-impedance when the chip is deselected or outputs are disabled. Data is internally latched during a write cycle.
$\overline{OE}$	INPUT		X	<b>OUTPUT ENABLE:</b> Gates the device's outputs during a read cycle.
$R/\overline{C}$	INPUT		X	<b>ROW-COLUMN ADDRESS SELECT:</b> For the A/A Mux interface, this pin determines whether the address pins are pointing to the row addresses, A0 - A10, or to the column addresses, A11 - A19.
$\overline{WE}$	INPUT		X	<b>WRITE ENABLE:</b> Controls writes to the array sectors. Addresses and data are latched on the rising edge of the $\overline{WE}$ pulse.
$V_{PP}$	SUPPLY	X	X	<b>SECTOR ERASE/PROGRAM POWER SUPPLY:</b> For erasing array sectors or programming data. $V_{PP} = 3.3V$ or $12V$ . With $V_{PP} \leq V_{PPLK}$ , memory contents cannot be altered. Sector erase or program with an invalid $V_{PP}$ (see DC Characteristics) produces spurious results and should not be attempted. $V_{PP}$ may only be held at $12V$ for 80 hours over the lifetime of the device.
$V_{CC}$	SUPPLY	X	X	<b>DEVICE POWER SUPPLY:</b> Internal detection automatically configures the device for optimized read performance. Do not float any power pins. With $V_{CC} \leq V_{LKO}$ , all write attempts to the flash memory are inhibited. Device operations at invalid $V_{CC}$ voltages (see DC Characteristics) produce spurious results and should not be attempted.
GND	SUPPLY	X	X	<b>GROUND:</b> Do not float any ground pins.
$V_{CCa}$	SUPPLY	X	X	<b>ANALOG POWER SUPPLY:</b> This supply should share the same system supply as $V_{CC}$ .
$GNDa$	SUPPLY	X	X	<b>ANALOG GROUND:</b> Should be tied to same plane as GND.
RFU		X		<b>RESERVED FOR FUTURE USE:</b> These pins are reserved for future generations of this product and should be connected accordingly. These pins may be left disconnected or driven. If they are driven, the voltage levels should meet $V_{IH}$ and $V_{IL}$ requirements. <b>A/A Mux = I/O[7:4]</b>
NC		X	X	<b>NO CONNECT:</b> Pin may be driven or floated. If it is driven, the voltage levels should meet $V_{IH}$ and $V_{IL}$ . No connects appear only on the 40-lead TSOP package.
$RY/\overline{BY}$	OUTPUT		X	<b>READY/BUSY:</b> Valid only in A/A Mux Mode. This output pin is a reflection of bit 7 in the status register. This pin is used to determine sector erase or program completion.

## 5. Firmware Hub Interface (FWH)

Table 5-1 lists the seven required signals used for the FWH interface.

**Table 5-1.** FWH Required Signal List

Signal	Direction		Description
	Peripheral	Master	
FWH[3:0]	I/O	I/O	Multiplexed command, address and data
FWH4	I	O	Indicates start of a new cycle, termination of broken cycle.
$\overline{\text{RST}}$	I	I	Reset: Same as PCI Reset on the master. The master does not need this signal if it already has $\overline{\text{PCIRST}}$ on its interface.
CLK	I	I	Clock: Same 33 MHz clock as PCI clock on the master. Same clock phase with typical PCI skew. The master does not need this signal if it already has PCICLK on its interface.

### 5.1 FWH[3:0]

The FWH[3:0] signal lines communicate address, control, and data information over the LPC bus between a master and a peripheral. The information communicated are: start, stop (abort a cycle), transfer type (memory, I/O, DMA), transfer direction (read/write), address, data, wait states, DMA channel, and bus master grant.

### 5.2 FWH4

FWH4 is used by the master to indicate the start of cycles and the termination of cycles due to an abort or time-out condition. This signal is to be used by peripherals to know when to monitor the bus for a cycle.

The FWH4 signal is used as a general notification that the FWH[3:0] lines contain information relative to the start or stop of a cycle, and that peripherals must monitor the bus to determine whether the cycle is intended for them. The benefit to peripherals of FWH4 is, it allows them to enter lower power states internally.

When peripherals sample FWH4 active, they are to immediately stop driving the FWH[3:0] signal lines on the next clock and monitor the bus for new cycle information.

### 5.3 Reset

$\overline{\text{RST}}$  or  $\overline{\text{INIT}}$  at VIL initiates a device reset. In read mode,  $\overline{\text{RST}}$  or  $\overline{\text{INIT}}$  low deselects the memory, places output drivers in a high-impedance state, and turns off all internal circuits.  $\overline{\text{RST}}$  or  $\overline{\text{INIT}}$  must be held low for time  $t_{\text{PLPH}}$  (A/A Mux and FWH operation). The FWH resets to read array mode upon return from reset, and all sectors are set to default (locked) status regardless of their locked state prior to reset.

Driving  $\overline{\text{RST}}$  or  $\overline{\text{INIT}}$  low resets the device, which resets the sector lock registers to their default (write-locked) condition. A reset time ( $t_{\text{PHQV}}$  A/A Mux) is required from  $\overline{\text{RST}}$  or  $\overline{\text{INIT}}$  switching high until outputs are valid. Likewise, the device has a wake time ( $t_{\text{PHRH}}$  A/A Mux) from  $\overline{\text{RST}}$  or  $\overline{\text{INIT}}$  high until writes to the CUI are recognized. A reset latency will occur if a reset procedure is performed during a programming or erase operation.

During sector erase or program, driving  $\overline{RST}$  or  $\overline{INIT}$  low will abort the operation underway, in addition to causing a reset latency. Memory contents being altered are no longer valid, since the data may be partially erased or programmed.

It is important to assert  $\overline{RST}$  or  $\overline{INIT}$  during system reset. When the system comes out of reset, it will expect to read from the memory array of the device. If a system reset occurs with no FWH reset (this will be hardware dependent), it is possible that proper CPU initialization will not occur (the FWH memory may be providing status information instead of memory array data).

## 5.4 Cycle Types

There are two types of cycles that are supported by the AT49LW080: FWH Memory Read and FWH Memory Write. FWH Memory Read or Write cycles start with a preamble.

### 5.4.1 Preamble

The preamble consists of a START, IDSEL, 28-bit Address and MSIZE fields. The preamble is shown in Figure 5-1. The preamble begins with FWH4 going low and a START field driven on FWH[3:0]. For FWH Memory Read cycles, the START field must be 1101b; for FWH Memory Write cycles, the START field must be 1110b. Following the START field is the IDSEL field. This field acts like a chip select in that it indicates which device should respond to the current transaction. The next seven clocks are the 28-bit address, which tell from where to begin reading or writing in the selected device. Next, an MSIZE value of 0 indicates the master is requesting a single byte.

**Figure 5-1.** FWH Memory Cycle Preamble

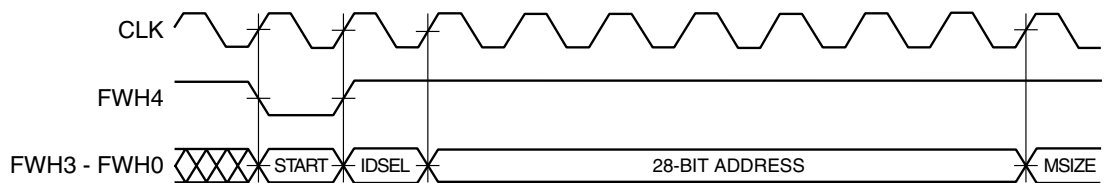

### 5.4.2 Start

This one-clock field indicates the start of a cycle. It is valid on the last clock that FWH4 is sampled low. The two start fields that are used for the cycle are shown in Table 5-2. If the start field that is sampled is not one of these values, then the cycle attempted is not an FWH memory cycle. It may be a valid memory cycle that the FWH component may wish to decode, i.e., it may be of the LPC memory cycle variety.

**Table 5-2.** Start Fields

FWH[3:0]	Indication
1101b	FWH Memory Read
1110b	FWH Memory Write

### 5.4.3 IDSEL (Device Select)

This one-clock field is used to indicate which FWH component is being selected. The four bits transmitted over FWH[3:0] during this clock are compared with values strapped onto pins [ID3:ID0] on the FWH component. If there is a match, the FWH component will continue to decode the cycle to determine which bytes are requested on a read or which bytes to update on a write. If there isn't a match, the FWH component may discard the rest of the cycle and go into a standby power state.

### 5.4.4 MADDR (Memory Address)

This is a seven-clock field, which gives a 28-bit memory address. This allows for up to 256 MB per memory device, for a total of a 4 GB addressable space. The address is transferred with the most significant nibble first.

### 5.4.5 MSIZE (Memory Size)

"0000b" will be sent in this field. A value of "0000b" corresponds to a single byte transfer.

## 6. Device Operation

### 6.1 Read

Read operations consist of preamble, TAR, SYNC and data fields as shown in [Figure 6-1](#) and described in [Table 6-2](#). TAR and SYNC fields are described below. Commands using the read mode include the following functions: reading memory from the array, reading the identifier codes, reading the lock bit registers and reading the GPI registers. Memory information, identifier codes, or the GPI registers can be read independent of the  $V_{PP}$  voltage. Upon initial device power-up or after exit from reset mode, the device automatically resets to read array mode.

#### 6.1.1 Read Cycle, Single Byte

For read cycles, after the preamble, the master drives a TAR field to give ownership of the bus to the FWH. After the second clock of the TAR phase the FWH assumes the bus and begins driving SYNC values. When it is ready, it drives the low nibble, then the high nibble of data, followed by a TAR field to give control back to the master.

[Figure 6-1](#) shows a device that requires three SYNC clocks to access data. Since the access time can begin once the address phase has been completed, the two clocks of the TAR phase can be considered as part of the access time of the part. For example, a device with a 120 ns access time could assert "0101b" for clocks 1 and 2 of the SYNC phase and "0000b" for the last clock of the SYNC phase. This would be equivalent to five clocks worth of access time if the device started that access at the conclusion of the preamble phase. Once SYNC is achieved, the device then returns the data in two clocks and gives ownership of the bus back to the master with a TAR phase.



## 6.1.2 Turn-around (TAR)

This field is two clocks wide, and is driven by the master when it is turning control over to the FWH, (for example, to read data), and is driven by the FWH when it is turning control back over to the master. On the first clock of this two-clock-wide field, the master or FWH drives the FWH[3:0] lines to “1111b”. On the second clock of this field, the master or peripheral tri-states the FWH[3:0] lines.

## 6.1.3 SYNC

This field is used to add wait states. It can be several clocks in length. On target or DMA cycles, this field is driven by the FWH. If the FWH needs to assert wait states, it does so by driving “0101b” (short SYNC) on FWH[3:0] until it is ready. When ready, it will drive “0000b”. Valid values for this field are shown in [Table 6-1](#).

**Table 6-1.** Valid SYNC Values

Bits[3:0]	Indication
0000	Ready: SYNC achieved with no error.
0101	Short Wait: Part indicating wait states.

**Figure 6-1.** FWH Single-byte Read Waveforms

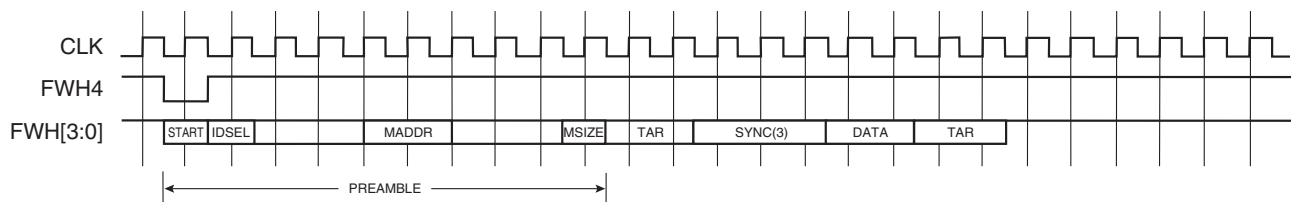

**Table 6-2.** FWH Read Cycle

Clock Cycle	Field Name	Field Contents <sup>(1)</sup> FWH[3:0]	FWH[3:0] Direction	Comments
1	START	1101b	IN	FWH4 must be active (low) for the part to respond. Only the last start field (before FWH4 transitioning high) should be recognized. The START field contents indicate an FWH memory read cycle.
2	IDSEL	0000b to 1111b	IN	Indicates which FWH device should respond. If the IDSEL (ID select) field matches the value ID[3:0], then that particular device will respond to subsequent commands.
3 - 9	MADDR	YYYY	IN	These seven clock cycles make up the 28-bit memory address. YYYY is one nibble of the entire address. Addresses are transferred most significant nibble first.
10	MSIZE	0000b (1 byte)	IN	The FWH will only support single-byte transfers.
11	TAR0	1111b	IN then Float	In this clock cycle, the master (ICH) has driven the bus to all 1s and then floats the bus, prior to the next clock cycle. This is the first part of the bus "turnaround cycle".
12	TAR1	1111b (float)	Float then OUT	The FWH takes control of the bus during this cycle. During the next clock cycle, it will be driving "sync data".
13 - 14	WSYNC	0101b (WAIT)	OUT	The FWH outputs the value 0101, a wait-sync (WSYNC, a.k.a. "short-sync"), for two clock cycles. This value indicates to the master (ICH) that data is not yet available from the part. This number of wait-syncs is a function of the device's access time.
15	RSYNC	0000b (READY)	OUT	During this clock cycle, the FWH will generate a "ready-sync" (RSYNC) indicating that the least significant nibble of the least significant byte will be available during the next clock cycle.
16	DATA	YYYY	OUT	YYYY is the least significant nibble of the least significant data byte.
17	DATA	YYYY	OUT	YYYY is the most significant nibble of the least significant data byte.
18	TAR0	1111b	OUT then Float	The FWH Flash memory drives FWH0 - FWH3 to 1111b to indicate a turnaround cycle.
19	TAR1	1111b (float)	Float then IN	The FWH Flash memory floats its outputs, the master (ICH) takes control of FWH3 - FWH0.

Note: 1. Field contents are valid on the rising edge of the present clock cycle.

## 6.2 Write

Write operations consist of preamble, data, TAR and SYNC fields as shown in Figure 6-2 and described in Table 6-3.

### 6.2.1 Write Cycles, Single Byte

All devices that support FWH Memory Write cycles must support single-byte writes. FWH Memory Write cycles use the same preamble as FWH Memory Read cycles.

For write cycles, after the preamble, the master writes the low nibble, then the high nibble of data. After that the master drives a TAR field to give ownership of the bus to the FWH. After the second clock of the TAR phase, the target device assumes the bus and begins driving SYNC values. A TAR field to give control back to the master follows this.

Figure 6-2. FWH Single-byte Write Waveforms

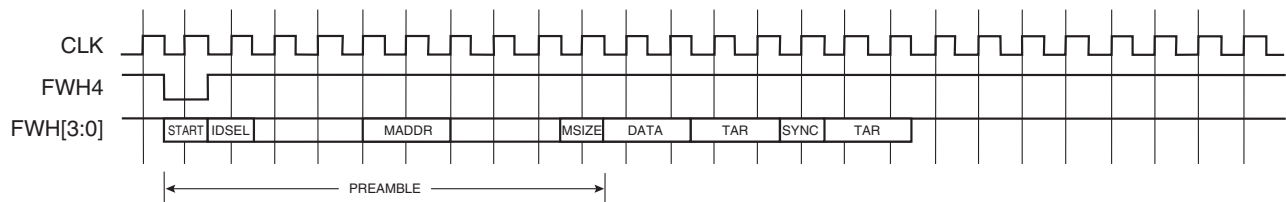

Table 6-3. FWH Write Cycle

Clock Cycle	Field Name	Field Contents <sup>(1)</sup> FWH[3:0]	FWH[3:0] Direction	Comments
1	START	1110b	IN	FWH4 must be active (low) for the part to respond. Only the last start field (before FWH4 transitioning high) should be recognized. The START field contents indicate an FWH memory write cycle.
2	IDSEL	0000b to 1111b	IN	Indicates which FWH device should respond. If the IDSEL (ID select) field matches the value ID[3:0], then that particular device will respond to subsequent commands.
3 - 9	MADDR	YYYY	IN	These seven clock cycles make up the 28-bit memory address. YYYY is one nibble of the entire address. Addresses are transferred most significant nibble first.
10	MSIZE	0000b (1 byte)	IN	The FWH only supports single-byte writes.
11	DATA	YYYY	IN	This field is the least significant nibble of the data byte. This data is either the data to be programmed into the Flash memory or any valid Flash command.
12	DATA	YYYY	IN	This field is the most significant nibble of the data byte.
13	TAR0	1111b	IN then float	In this clock cycle, the master (ICH) has driven the bus to all 1s and then floats the bus prior to the next clock cycle. This is the first part of the bus "turnaround cycle".
14	TAR1	1111b (float)	Float then OUT	The FWH takes control of the bus during this cycle. During the next clock cycle it will be driving the "sync" data.
15	RSYNC	0000b	OUT	The FWH outputs the values 0000, indicating that it has received data or a Flash command.
16	TAR0	1111b	OUT then Float	The FWH Flash memory drives FWH0 - FWH 3 to 1111b to indicate a turnaround cycle.
17	TAR1	1111b (float)	Float then IN	The FWH Flash memory floats its outputs, the master (ICH) takes control of FWH3 - FWH0.

Note: 1. Field contents are valid on the rising edge of the present clock cycle.

### 6.3 Output Disable

When the FWH is not selected through a FWH read or write cycle, the FWH interface outputs (FWH[3:0]) are disabled and will be placed in a high-impedance state.

### 6.4 Response to Invalid Fields

During FWH operations, the FWH will not explicitly indicate that it has received invalid field sequences. The response to specific invalid fields or sequences is as follows:

- **Address out of range:** The FWH address sequences is seven fields long (28 bits), but only the last five address fields (20 bits) will be decoded by an 8-Mbit FWH. The FWH will respond to these lower addresses, regardless of the value of the more-significant address bits. Address A22 has the special function of directing reads and writes to the Flash core (A22 = 1) or to the register space (A22 = 0).
- **Invalid MSIZE field:** If the FWH receives an invalid size field during a read or write operation, the internal state machine will reset and no operation will be attempted. The FWH will generate no response of any kind in this situation. Invalid-size fields for a read cycle are anything but 0000. Invalid-size fields for a write cycle are anything but 0000. When accessing register space, invalid field sizes are anything but 0000.

Once valid START, IDSEL, and MSIZE fields are received, the FWH always will respond to subsequent inputs as if they were valid. As long as the states of FWH [3:0] and FWH4 are known, the response of the FWH to signals received during the FWH cycle should be predictable. The FWH will make no attempt to check the validity of incoming Flash operation commands.

### 6.5 Bus Abort

The Bus Abort operation can be used to immediately abort the current bus operation. A Bus Abort occurs when FWH4 is driven Low,  $V_{IL}$ , during the bus operation; the memory will tri-state the Input/Output Communication pins, FWH3 - FWH0 and the FWH state machine will reset. During a write cycle, there is the possibility that an internal Flash write or erase operation is in progress (or has just been initiated). If the FWH4 is asserted during this time frame, the internal operation will not abort. The software must send an explicit Flash command to terminate or suspend the operation. The internal FWH state machine will not initiate a Flash write or erase operation until it has received the last nibble from the chipset. This means that FWH4 can be asserted as late as cycle 12 (Table 6-3) and no internal Flash operation will be attempted.

### 6.6 Hardware Write-protect Pins $\overline{TBL}$ and $\overline{WP}$

Two pins are available with the FWH to provide hardware write-protect capabilities.

The Top Sector Lock ( $\overline{TBL}$ ) pin is a signal, when held low (active), prevents program or sector erase operations in the top sector of the device (15) where critical code can be stored. When  $\overline{TBL}$  is high, hardware write protection of the top sector is disabled. The write-protect ( $\overline{WP}$ ) pin serves the same function for all the remaining sectors except the top sector.  $\overline{WP}$  operates independently from  $\overline{TBL}$  and does not affect the lock status of the top sector.

The  $\overline{TBL}$  and  $\overline{WP}$  pins must be set to the desired protection state prior to starting a program or erase operation since they are sampled at the beginning of the operation. Changing the state of  $\overline{TBL}$  or  $\overline{WP}$  during a program or erase operation may cause unpredictable results.

If the state of  $\overline{TBL}$  or  $\overline{WP}$  changes during a program suspend or erase suspend state, the changes to the device's locking status do not take place immediately. The suspended operation

may be resumed to successfully complete the program or erase operation. The new lock status will take place after the program or erase operation completes.

These pins function in combination with the register-based sector locking (to be explained later). These pins, when active, will write-protect the appropriate sector(s), regardless of the associated sector locking registers. (For example, when  $\overline{\text{TBL}}$  is active, writing to the top sector is prevented, regardless of the state of the Write Lock bit for the top sector's locking register. In such a case, clearing the write-protect bit in the register will have no functional effect, even though the register may indicate that the sector is no longer locked. The register may still be set to read-lock the sector, if desired.)

**Table 6-4.** Device Memory Map with FWH Hardware Lock Architecture

Sector	Size (Bytes)	Address Range	Hardware Write-protect Pin
SA0	64K	00000 - 0FFFF	$\overline{\text{WP}}$
SA1	64K	10000 - 1FFFF	$\overline{\text{WP}}$
SA2	64K	20000 - 2FFFF	$\overline{\text{WP}}$
SA3	64K	30000 - 3FFFF	$\overline{\text{WP}}$
SA4	64K	40000 - 4FFFF	$\overline{\text{WP}}$
SA5	64K	50000 - 5FFFF	$\overline{\text{WP}}$
SA6	64K	60000 - 6FFFF	$\overline{\text{WP}}$
SA7	64K	70000 - 7FFFF	$\overline{\text{WP}}$
SA8	64K	80000 - 8FFFF	$\overline{\text{WP}}$
SA9	64K	90000 - 9FFFF	$\overline{\text{WP}}$
SA10	64K	A0000 - AFFFF	$\overline{\text{WP}}$
SA11	64K	B0000 - BFFFF	$\overline{\text{WP}}$
SA12	64K	C0000 - CFFFF	$\overline{\text{WP}}$
SA13	64K	D0000 - DFFFF	$\overline{\text{WP}}$
SA14	64K	E0000 - EFFFF	$\overline{\text{WP}}$
SA15	64K	F0000 - FFFFF	$\overline{\text{TBL}}$

## 6.7 Register-based Locking and General-purpose Input Registers

A series of registers are available in the FWH to provide software read and write locking and GPI feedback. These registers are accessible through standard addressable memory space.

### 6.7.1 Registers

The AT49LW080 has two types of registers: sector-locking registers and general-purpose input registers. The two types of registers appear at their respective address locations in the 4 GB system memory map.

### 6.7.2 Sector-locking Registers

The AT49LW080 has 16 (LR0 - LR15) sector-locking registers. Each sector-locking register controls the lock protection for 64K bytes of memory as shown in [Table 6-5](#). The sector-locking registers are accessible through the register memory address shown in the third column of [Table 6-5](#). The sector-locking registers are read/write as shown in the last column of [Table 6-5](#). Each sector has three dedicated locking bits as shown in [Table 6-6](#) and [Table 6-7](#).

**Table 6-5.** Sector-locking Registers for AT49LW080

Register Name	Sector Size	Register Memory Address	Default Value	Type
LR0	64K	FFB0002H	01H	R/W
LR1	64K	FFB1002H	01H	R/W
LR2	64K	FFB2002H	01H	R/W
LR3	64K	FFB3002H	01H	R/W
LR4	64K	FFB4002H	01H	R/W
LR5	64K	FFB5002H	01H	R/W
LR6	64K	FFB6002H	01H	R/W
LR7	64K	FFB7002H	01H	R/W
LR8	64K	FFB8002H	01H	R/W
LR9	64K	FFB9002H	01H	R/W
LR10	64K	FFBA002H	01H	R/W
LR11	64K	FFBB002H	01H	R/W
LR12	64K	FFBC002H	01H	R/W
LR13	64K	FFBD002H	01H	R/W
LR14	64K	FFBE002H	01H	R/W
LR15	64K	FFBF002H	01H	R/W
FGPI-REG		FFBC0100H	N/A	RO

**Table 6-6.** Function of Sector-locking Bits

Bit	Function
7:3	<b>Reserved</b>
2	<b>Read Lock</b> 1 = Prevents read operations in the sector where set. 0 = Normal operation for reads in the sector where clear. This is the default state.
1	<b>Lock-down</b> 1 = Prevents further set or clear operations to the Write Lock and Read Lock bits. Lock-down can only be set, but not cleared. The sector will remain locked-down until reset (with $\overline{RST}$ or $\overline{INIT}$ ), or until the device is power-cycled. 0 = Normal operation for Write Lock and Read Lock bits altering in the sector where clear. This is the default state.
0	<b>Write Lock</b> 1 = Prevents program or erase operations in the sector where set. This is the default state. 0 = Normal operation for programming and erase in the sector where clear.

**Table 6-7.** Register-based Locking Value Definitions

Data	Reserved Data 7 - 3	Read Lock, Data 2	Lock-down, Data 1	Write Lock, Data 0	Resulting Sector State <sup>(1)</sup>
00	00000	0	0	0	Full access
01	00000	0	0	1	Write locked. <b>Default state at power-up</b>
02	00000	0	1	0	Locked open (full access locked down)
03	00000	0	1	1	Write locked down
04	00000	1	0	0	Read locked
05	00000	1	0	1	Read and write locked
06	00000	1	1	0	Read locked down
07	00000	1	1	1	Read and write locked down

Note: 1. The Write Lock bit must be set to the desired protection state prior to starting a program or erase operation since it is sampled at the beginning of the operation. Changing the state of the Write Lock bit during a program or erase operation may cause unpredictable results. If the state of the Write Lock bit changes during a program suspend or erase suspend state, the changes to the sector's locking status do not take place immediately. The suspended operation may be resumed successfully. The new lock status will take place after the program or erase operation completes. The individual bit functions are described in the following sections.

### 6.8 Read Lock

The default read status of all sectors upon power-up is read-unlocked. When a sector's read-lock bit is set (1 state), data cannot be read from that sector. An attempted read from a read-locked sector will result in data 00H being read. (Note that failure is not reflected in the status register). The read-lock status can be unlocked by clearing (0 state) the read-lock bit, provided the lock-down bit has not been set. The current read-lock status of a particular sector can be determined by reading the corresponding read-lock bit.

### 6.9 Write Lock

The default write status of all sectors upon power-up is write-locked (1 state). Any program or erase operations attempted on a locked sector will return an error in the status register (indicating sector lock). The status of the locked sector can be changed to unlocked (0 state) by clearing the write-lock bit, provided the lock-down bit is not also set. The current write-lock status of a particular sector can be determined by reading the corresponding write-lock bit. Any program or erase operations attempted on a locked sector will return an error in the status register (indicating sector lock). The write-lock functions in conjunction with the hardware write-lock pins,  $\overline{\text{TBL}}$  and  $\overline{\text{WP}}$ . When active, these pins take precedence over the register-locking function and write-lock the top sector or remaining sectors, respectively. Reading this register will not read the state of the  $\overline{\text{TBL}}$  or  $\overline{\text{WP}}$  pins.

## 6.10 Lock-down

When in the FWH interface mode, the default lock-down status of all sectors upon power-up is not-locked-down (0 state). The lock-down bit for any sector may be set (1 state), but only once, as future attempted changes to that sector locking register will be ignored. The lock-down bit is only cleared upon a device reset with  $\overline{RST}$  or  $\overline{INIT}$ . The current lock-down status of a particular sector can be determined by reading the corresponding lock-down bit. Once a sector's lock-down bit is set, the read- and write-lock bits for that sector can no longer be modified and the sector is locked down in its current state of read and write accessibility.

## 6.11 General-purpose Inputs Register

This register reads the status of the FGPI[4:0] pins on the FWH at power-up. Since this is a pass-through register, there is no default value as shown in [Table 6-5](#). It is recommended that the GPI pins be in the desired state before FWH4 is brought low for the beginning of the next bus cycle, and remain in that state until the end of the cycle.

**Table 6-8.** General-purpose Input Registers

Bit	Function
7:5	Reserved
4	<b>FGPI[4]</b> Reads status of general-purpose input pin (PLCC-30/TSOP-7)
3	<b>FGPI[3]</b> Reads status of general-purpose input pin (PLCC-3/TSOP-15)
2	<b>FGPI[2]</b> Reads status of general-purpose input pin (PLCC-4/TSOP-16)
1	<b>FGPI[1]</b> Reads status of general-purpose input pin (PLCC-5/TSOP-17)
0	<b>FGPI[0]</b> Reads status of general-purpose input pin (PLCC-6/TSOP-18)



## 7. Command Definitions Table

Command Sequence	Bus Cycles	Operation	1st Bus Cycle		Operation	2nd Bus Cycle	
			Addr	Data		Addr	Data
Read Array/Reset	1	Write	XXXX	FF			
Sector Erase <sup>(2)(3)</sup>	2	Write	SA	20	Write	SA	D0
Byte Program <sup>(2)(4)</sup>	2	Write	Addr	40 or 10	Write	Addr	D <sub>IN</sub>
Sector Erase Suspend <sup>(2)</sup>	1	Write	XXXX	B0			
Program Suspend <sup>(2)</sup>		Write					
Sector Erase Resume <sup>(2)</sup>	1	Write	XXXX	D0			
Program Resume <sup>(2)</sup>		Write					
Product ID Entry <sup>(5)</sup>	2	Write	XXXX	90	Read	AID <sup>(6)</sup>	D <sub>OUT</sub>
Read Status Register	2	Write	XXXX	70	Read	XXXX	SRD <sup>(7)</sup>
Clear Status Register	1	Write	XXXX	50			

- Notes:
1. X = Any valid address within the device
  2. The sector must not be write locked when attempting sector erase or program operations. Attempts to issue a sector erase or byte program to a write locked sector will fail.
  3. SA = Sector address. Any byte address within a sector can be used to designate the sector address (see [page 13](#)).
  4. Either 40H or 10H is recognized as the program setup.
  5. Following the Product ID Entry command, read operations access manufacture and device ID. See [Table 7-1](#).
  6. AID = Address used to read data for manufacture or device ID
  7. SRD = Data Read from status register

### 7.1 Read Array

Upon initial device power-up and after exit from reset, the device defaults to read array mode. This operation is also initiated by writing the Read Array command. The device remains enabled for reads until another command is written. Once the internal state machine (WSM) has started a block erase or program operation, the device will not recognize the Read Array Command until the operation is completed, unless the operation is suspended via an Erase Suspend or Program Suspend Command. The Read Array command functions independently of the V<sub>PP</sub> voltage.

### 7.2 Product Identification

The product identification mode identifies the device and manufacturer as Atmel.

Following the Product ID Entry command, read cycles from the addresses shown in [Table 7-1](#) retrieve the manufacturer and device code. To exit the product identification mode, any valid command can be written to the device. The Product ID Entry command functions independently of the V<sub>PP</sub> voltage.

**Table 7-1.** Identifier Codes

Code	Address (AID)	Data
Manufacturer Code	000000	1F
Device Code	000001	E1

### 7.3 Sector Erase

Before a byte can be programmed, it must be erased. The erased state of the memory bits is a logical “1”. Since the AT49LW080 does not offer a complete chip erase, the device is organized into multiple sectors that can be individually erased. The Sector Erase command is a two-bus cycle operation.

Successful sector erase requires that the corresponding sector’s Write Lock bit be cleared and the corresponding write-protect pin ( $\overline{\text{TBL}}$  or  $\overline{\text{WP}}$ ) be inactive. If sector erase is attempted when the sector is locked, the sector erase will fail, with the reason for failure in the status register.

Successful sector erase only occurs when  $V_{\text{PP}} = V_{\text{PPH1}}$  or  $V_{\text{PPH2}}$ . If the erase operation is attempted at  $V_{\text{PP}} \neq V_{\text{PPH1}}$  or  $V_{\text{PPH2}}$  erratic results may occur.

### 7.4 Byte Programming

The device is programmed on a byte-by-byte basis. Programming is accomplished via the internal device command register and is a two-bus cycle operation. The programming address and data are latched in the second bus cycle. The device will automatically generate the required internal programming pulses. Please note that a “0” cannot be programmed back to a “1”; only an erase operation can convert “0”s to “1”s.

After the program command is written, the device automatically outputs the status register data when read. When programming is complete, the status register may be checked. If a program error is detected, the status register should be cleared before corrective action is taken by the software. The internal WSM verification Error Checking only detects “1”s that do not successfully program to “0”s.

Reliable programming only occurs when  $V_{\text{PP}} = V_{\text{PPH1}}$  or  $V_{\text{PPH2}}$ . If the program operation is attempted at  $V_{\text{PP}} \neq V_{\text{PPH1}}$  or  $V_{\text{PPH2}}$  erratic results may occur.

A successful program operation also requires that the corresponding sector’s Write Lock bit be cleared, and the corresponding write-protect pin ( $\overline{\text{TBL}}$  or  $\overline{\text{WP}}$ ) be inactive. If a program operation is attempted when the sector is locked, the operation will fail.

### 7.5 Erase Suspend

The Erase Suspend command allows sector-erase interruption to read or program data in another sector of memory. Once the sector erase process starts, writing the sector erase suspend command requests that the WSM suspend the sector erase sequence at a predetermined point in the algorithm. The device outputs status register data when read after the sector erase suspend command is written. Polling the status register can help determine when the sector erase operation was suspended. After a successful suspend, a Read Array command can be written to read data from a sector other than the suspended sector. A program command sequence may also be issued during erase suspend to program data in sectors other than the sector currently in the erase suspend mode.

The other valid commands while sector erase is suspended include Read Status Register and Sector Erase Resume. After a Sector Erase Resume command is written, the WSM will continue the sector erase process.  $V_{\text{PP}}$  must remain at  $V_{\text{PPH1/2}}$  (the same  $V_{\text{PP}}$  level initially used for sector erase) while sector erase is suspended.  $\overline{\text{RST}}$  or  $\overline{\text{INIT}}$  must also remain at  $V_{\text{IH}}$ . Sector erase cannot resume until program operations initiated during sector erase suspend have completed.

## 7.6 Program Suspend

The Program Suspend command allows program interruption to read data in other memory locations. Once the program process starts, writing the Program Suspend Command requests that the WSM suspend the program sequence at a predetermined point in the algorithm. The device continues to output status register data when read after the program suspend command is written. Polling the status register can help determine when the program operation was suspended. After a successful suspend, a Read Array command can be written to read data from locations other than that which is suspended. The only other valid commands while program is suspended are Read Status Register and Program Resume.  $V_{PP}$  must remain at  $V_{PPH1/2}$  (the same  $V_{PP}$  level used for program) while in program suspend mode.  $\overline{RST}$  or  $\overline{INIT}$  must also remain at  $V_{IH}$ .

## 7.7 Read Status Register

The status register may be read to determine when a sector erase or program completes and whether the operation completed successfully. The status register may be read at any time by writing the Read Status Register command. After writing this command, all subsequent read operations will return data from the status register until another valid command is written. The Read Status Register command functions independently of the  $V_{PP}$  voltage.

## 7.8 Clear Status Register

Error flags in the status register can only be set to "1"s by the WSM and can only be reset by the Clear Status Register command. These bits indicate various failure conditions. The Clear Status Register command functions independently of the applied  $V_{PP}$  voltage.

## 7.9 Status Register Definition

B7	Write State Machine Status <sup>(1)</sup>	1	Ready
		0	Busy
B6	Erase Suspend Status	1	Sector Erase Suspended
		0	Sector Erase in Progress/Completed
B5	Erase Status <sup>(2)</sup>	1	Error in Sector Erasure
		0	Successful Sector Erase
B4	Program Status	1	Error in Program
		0	Successful Program
B3	V <sub>PP</sub> Status <sup>(3)</sup>	1	V <sub>PP</sub> Low Detect, Operation Abort
		0	V <sub>PP</sub> OK
B2	Program Suspend Status	1	Program Suspended
		0	Program in Progress/Completed
B1	Device Protect Status <sup>(4)</sup>	1	Write Lock Bit, $\overline{\text{TBL}}$ Pin or $\overline{\text{WP}}$ Pin Detected, Operation Abort
		0	Unlock
B0	Reserved for Future Enhancements <sup>(5)</sup>		

- Notes:
1. Check B7 to determine sector erase or program completion. B6 - B0 are invalid while B7 = "0".
  2. If both B5 and B4 are "1"s after a sector erase attempt, an improper command sequence was entered.
  3. B3 does not provide a continuous indication of V<sub>PP</sub> level. The WSM interrogates and indicates the V<sub>PP</sub> level only after a sector erase or program operation. B3 is not guaranteed to report accurate feedback only when V<sub>PP</sub> ≠ V<sub>PPH1/2</sub>.
  4. B1 does not provide a continuous indication of Write Lock bit,  $\overline{\text{TBL}}$  pin or  $\overline{\text{WP}}$  pin values. The WSM interrogates the Write Lock bit,  $\overline{\text{TBL}}$  pin or  $\overline{\text{WP}}$  pin only after a sector erase or program operation. Depending on the attempted operation, it informs the system whether or not the selected sector is locked.
  5. B0 is reserved for future use and should be masked out when polling the status register.

## 8. A/A Mux Interface

The following information applies *only* to the AT49LW080 when in A/A Mux Mode. Information on FWH Mode (the standard operating mode) is detailed earlier in this document. Electrical characteristics in A/A Mux Mode are provided on pages starting from [page 28](#)

The AT49LW080 is designed to offer a parallel programming mode for faster factory programming. This mode, called A/A Mux Mode, is selected by having this IC pin high. The IC pin is pulled down internally in the AT49LW080, so a modest current should be expected to be drawn (see [Table 4-1 on page 4](#) for further information). Four control pins dictate data flow in and out of the component:  $\overline{R/C}$ ,  $\overline{OE}$ ,  $\overline{WE}$ , and  $\overline{RST}$ .  $\overline{R/C}$  is the A/A Mux control pin used to latch row and column addresses.  $\overline{OE}$  is the data output control pin (I/O0 - I/O7), drives the selected memory data onto the I/O bus, when active  $\overline{WE}$  and  $\overline{RST}$  must be at  $V_{IH}$ .

### 8.1 Bus Operation

All A/A Mux bus cycles can be conformed to operate on most automated test equipment and PROM programmers.

Mode	$\overline{RST}$	$\overline{OE}$	$\overline{WE}$	Address	$V_{PP}$	I/O0 - I/O7
Read <sup>(1)(2)(6)</sup>	$V_{IH}$	$V_{IL}$	$V_{IH}$	X	X	$D_{OUT}$
Output Disable <sup>(6)</sup>	$V_{IH}$	$V_{IH}$	$V_{IH}$	X	X	High-Z
Product ID Entry <sup>(6)</sup>	$V_{IH}$	$V_{IL}$	$V_{IH}$	<sup>(3)</sup>	X	Note 3
Write <sup>(4)(5)(6)</sup>	$V_{IH}$	$V_{IH}$	$V_{IL}$	X	X	$D_{IN}$

- Notes:
1. When  $V_{PP} \leq V_{PPLK}$ , the memory contents can be read, but not altered.
  2. X can be  $V_{IL}$  or  $V_{IH}$  for control and address input pins and  $V_{PPLK}$  or  $V_{PPH1/2}$  for the VPP supply pin. See the “DC Characteristics” for  $V_{PPLK}$  and  $V_{PPH1/2}$  voltages.
  3. See [Table 7-1 on page 17](#) for Product ID Entry data and addresses.
  4. Command writes involving sector erase or program are reliably executed when  $V_{PP} = V_{PPH1/2}$  and  $V_{CC} = V_{CC} \pm 0.3V$ .
  5. Refer to “A/A Mux Read-only Operations” for valid  $D_{IN}$  during a write operation.
  6.  $V_{IH}$  and  $V_{IL}$  refer to the DC characteristics associated with Flash memory output buffers:  $V_{IL\ min} = 0.5V$ ,  $V_{IL\ max} = 0.8V$ ,  $V_{IH\ min} = 2.0V$ ,  $V_{IH\ max} = V_{CC} + 0.5V$ .

### 8.2 Output Disable/Enable

With  $\overline{OE}$  at a logic-high level ( $V_{IH}$ ), the device outputs are disabled. Output pins I/O0 - I/O7 are placed in the high-impedance state. With  $\overline{OE}$  at a logic-low level ( $V_{IL}$ ), the device outputs are enabled. Output pins I/O0 - I/O7 are placed in a output-drive state.

### 8.3 Row/Column Addresses

$\overline{R/C}$  is the A/A Mux control pin used to latch row (A0 - A10) and column addresses (A11 - A19).  $\overline{R/C}$  latches row addresses on the falling edge and column addresses on the rising edge.

### 8.4 RDY/ $\overline{BUSY}$

An open drain Ready/ $\overline{Busy}$  output pin provides a hardware method of detecting the end of a program or erase operation. RDY/ $\overline{Busy}$  is actively pulled low during the internal program and erase cycles and is released at the completion of the cycle.

## 9. Absolute Maximum Ratings\*

Voltage on Any Pin (except $V_{PP}$ ) .....	-0.5V to $V_{CC} + 0.5V$ <sup>(1)(2)(4)</sup>
$V_{PP}$ Voltage .....	-0.5V to +13.0V <sup>(1)(2)(3)</sup>

\*NOTICE: Stresses beyond those listed under “Absolute Maximum Ratings” may cause permanent damage to the device. This is a stress rating only and functional operation of the device at these or any other conditions beyond those indicated in the operational sections of this specification is not implied. Exposure to absolute maximum rating conditions for extended periods may affect device reliability.

- Notes:
1. All specified voltages are with respect to GND. Minimum DC voltage on the  $V_{PP}$  pin is -0.5V. During transitions, this level may undershoot to -2.0V for periods of <20 ns. During transitions, this level may overshoot to  $V_{CC} + 2.0V$  for periods <20 ns.
  2. Maximum DC voltage on  $V_{PP}$  may overshoot to +13.0V for periods <20 ns.
  3. Connection to supply of  $V_{HH}$  is allowed for a maximum cumulative period of 80 hours.
  4. Do not violate processor or chipset limitations on the  $\overline{INIT}$  pin.

## 10. Operating Conditions

Temperature and  $V_{CC}$

Symbol	Parameter	Test Condition	Min	Max	Unit
$T_C$	Operating Temperature <sup>(1)</sup>	Case Temperature	0	+85	°C
$V_{CC}$	$V_{CC}$ Supply Voltage ( $3.3V \pm 0.3V$ )		3.0	3.6	V

- Note: 1. This temperature requirement is different from the normal commercial operating condition of Flash memories.

## 11. FWH Interface DC Input/Output Specifications

Symbol	Parameter	Conditions	Min	Max	Units
$V_{IH}$ <sup>(3)</sup>	Input High Voltage		0.5 $V_{CC}$	$V_{CC} + 0.5$	V
$V_{IH}(\overline{INIT})$ <sup>(5)</sup>	$\overline{INIT}$ Input High Voltage		1.35	$V_{CC} + 0.5$	V
$V_{IL}(\overline{INIT})$ <sup>(5)</sup>	$\overline{INIT}$ Input Low Voltage			0.85	V
$V_{IL}$ <sup>(3)</sup>	Input Low Voltage		-0.5	0.3 $V_{CC}$	V
$I_{IL}$ <sup>(4)</sup>	Input Leakage Current <sup>(1)</sup>	$0 < V_{IN} < V_{CC}$		$\pm 10$	$\mu A$
$V_{OH}$	Output High Voltage	$I_{OUT} = -500 \mu A$	0.9 $V_{CC}$		V
$V_{OL}$	Output Low Voltage	$I_{OUT} = 1500 \mu A$		0.1 $V_{CC}$	V
$C_{IN}$	Input Pin Capacitance			13	pF
$C_{CLK}$	CLK Pin Capacitance		3	12	pF
$L^{pin}$ <sup>(2)</sup>	Recommended Pin Inductance			20	nH

- Notes:
1. Input leakage currents include high-Z output leakage for all bi-directional buffers with tri-state outputs.
  2. Refer to PCI spec.
  3. Inputs are not “5-volt safe.”
  4.  $I_{IL}$  may be changed on IC and ID pins (up to 200  $\mu A$ ) if pulled against internal pull-downs. Refer to the pin descriptions
  5. Do not violate processor or chipset specifications regarding the  $\overline{INIT}$  pin voltage.

## 12. Power Supply Specifications – All Interfaces

Symbol	Parameter	Conditions	Min	Max	Units
V <sub>PPH1</sub>	V <sub>PP</sub> Voltage		3.0	3.6	V
V <sub>PPH2</sub>	V <sub>PP</sub> Voltage		11.4	12.6	V
V <sub>PPLK</sub>	V <sub>PP</sub> Lockout Voltage		1.5		V
V <sub>LKO</sub>	V <sub>CC</sub> Lockout Voltage		1.5		V
I <sub>CCSL1</sub>	V <sub>CC</sub> Standby Current (FWH Interface) <sup>(2)</sup>	Voltage range of all inputs is V <sub>IH</sub> to V <sub>IL</sub> , FWH4 = V <sub>IH</sub> , <sup>(3)</sup>  V <sub>CC</sub> = 3.6V, CLK f = 33 MHz  No internal operations in progress		100 <sup>(4)</sup>	μA
I <sub>CCSL2</sub>	V <sub>CC</sub> Standby Current (FWH Interface) <sup>(2)</sup>	FWH4 = V <sub>IL</sub> , <sup>(3)</sup>  V <sub>CC</sub> = 3.6V, CLK f = 33 MHz  No internal operations in progress		10 <sup>(4)</sup>	mA
I <sub>CCA</sub>	V <sub>CC</sub> Active Current <sup>(2)</sup>	V <sub>CC</sub> = V <sub>CC</sub> Max, <sup>(3)</sup> CLK f = 33 MHz  Any internal operation in progress,  I <sub>OUT</sub> = 0 mA		67 <sup>(4)</sup>	mA
I <sub>PPR</sub>	V <sub>PP</sub> Read Current <sup>(2)</sup>	V <sub>PP</sub> ≥ V <sub>CC</sub>		200	μA
I <sub>PPWE</sub>	V <sub>PP</sub> Program or Erase Current	V <sub>PP</sub> = 3.0 - 3.6V <sup>(2)</sup>		40	mA
		V <sub>PP</sub> = 11.4 - 12.6V <sup>(2)</sup>		15	mA

- Notes:
1. All currents are in RMS unless otherwise noted. These currents are valid for all packages.
  2. V<sub>PP</sub> = V<sub>CC</sub>.
  3. V<sub>IH</sub> = 0.9 V<sub>CC</sub>, V<sub>IL</sub> = 0.1 V<sub>CC</sub> per the PCI output V<sub>OH</sub> and V<sub>OL</sub> spec.
  4. This number is the worst case of I<sub>PP</sub> + I<sub>CC</sub> Memory Core + I<sub>CC</sub> FWH Interface.

### 13. FWH Interface AC Input/Output Specifications

Symbol	Parameter	Condition	Min	Max	Units
$I_{oh}(AC)$	Switching Current High	$0 < V_{OUT} \leq 0.3 V_{CC}$	$-12 V_{CC}$		mA
		$0.3 V_{CC} < V_{OUT} < 0.9 V_{CC}$	$-17.1 (V_{CC} - V_{OUT})$		mA
		$0.7 V_{CC} < V_{OUT} < V_{CC}$		Note 2	
	(Test Point)	$V_{OUT} = 0.7 V_{CC}$		$-32 V_{CC}$	mA
$I_{ol}(AC)$	Switching Current Low	$V_{CC} > V_{OUT} \geq 0.6 V_{CC}$	$16 V_{CC}$		mA
		$0.6 V_{CC} > V_{OUT} > 0.1 V_{CC}$	$-17.1 (V_{CC} - V_{OUT})$		mA
		$0.18 V_{CC} > V_{OUT} > 0$		Note 3	
		(Test Point)	$V_{OUT} = 0.18 V_{CC}$		$38 V_{CC}$
$I_{cl}$	Low Clamp Current	$-3 < V_{IN} \leq -1$	$-25 + (V_{IN} + 1)/0.015$		mA
$I_{ch}$	High Clamp Current	$V_{CC} + 4 > V_{IN} \geq V_{CC} + 1$	$25 + (V_{IN} - V_{CC} - 1)/0.015$		mA
slewr	Output Rise Slew Rate	$0.2 V_{CC} - 0.6 V_{CC}$ load <sup>(1)</sup>	1	4	V/ns
slewf	Output Fall Slew Rate	$0.6 V_{CC} - 0.2 V_{CC}$ load <sup>(1)</sup>	1	4	V/ns

- Notes:
1. PCI specification output load is used.
  2.  $I_{OH} = (98.0/V_{CC}) * (V_{OUT} - V_{CC}) * (V_{OUT} + 0.4 V_{CC})$ .
  3.  $I_{OL} = (256/V_{CC}) * V_{OUT} (V_{CC} - V_{OUT})$ .

### 14. FWH Interface AC Timing Specifications

#### 14.1 Clock Specification

Symbol	Parameter	Condition	Min	Max	Units
$t_{CYC}$	CLK Cycle Time <sup>(1)</sup>		30	•	ns
$t_{HIGH}$	CLK High Time		11		ns
$t_{LOW}$	CLK Low Time		11		ns
-	CLK Slew Rate	peak-to-peak	1	4	V/ns
-	$\overline{RST}$ or $\overline{INIT}$ Slew Rate <sup>(2)</sup>		50		mV/ns

- Notes:
1. PCI components must work with any clock frequency between nominal DC and 33 MHz. Frequencies less than 16 MHz may be guaranteed by design rather than testing.
  2. Applies only to rising edge of signal.

#### 14.2 Clock Waveform

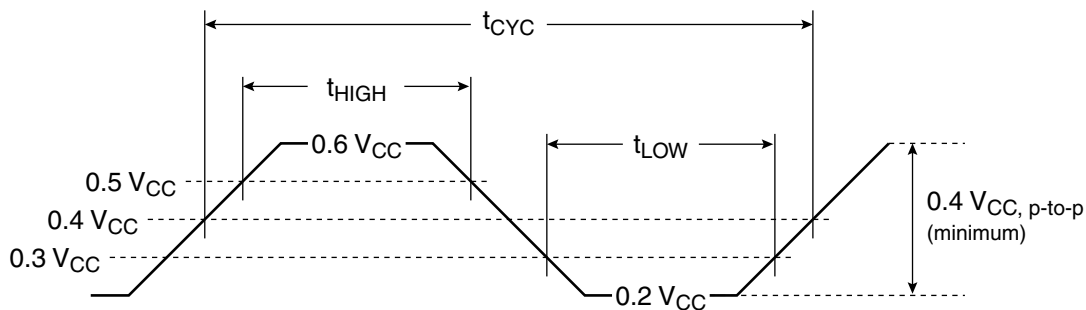



### 15. Signal Timing Parameters

Symbol	PCI Symbol	Parameter	Min	Max	Units
$t_{CHQX}$	$t_{VAL}$	CLK to Data Out <sup>(1)</sup>	2	11	ns
$t_{CHQX}$	$t_{ON}$	CLK to Active (Float to Active Delay) <sup>(2)</sup>	2		ns
$t_{CHQZ}$	$t_{OFF}$	CLK to Inactive (Active to Float Delay) <sup>(2)</sup>		28	ns
$t_{AVCH}$ $t_{DVCH}$	$t_{SU}$	Input Set-up Time <sup>(3)</sup>	9		ns
$t_{CHAX}$ $t_{CHDX}$	$t_H$	Input Hold Time <sup>(3)</sup>	0		ns
$t_{VSPL}$	$t_{RST}$	Reset Active Time after Power Stable	1		ms
$t_{CSPL}$	$t_{RST-CLK}$	Reset Active Time after CLK Stable	100		$\mu$ s
$t_{PLQZ}$	$t_{RST-OFF}$	Reset Active to Output Float Delay <sup>(2)</sup>		48	ns

- Notes:
1. Minimum and maximum times have different loads. See PCI spec.
  2. For purposes of Active/Float timing measurements, the high-Z or "off" state is defined to be when the total current delivered through the component pin is less than or equal to the leakage current specification.
  3. This parameter applies to any input type (excluding CLK).

### 16. Output Timing Parameters

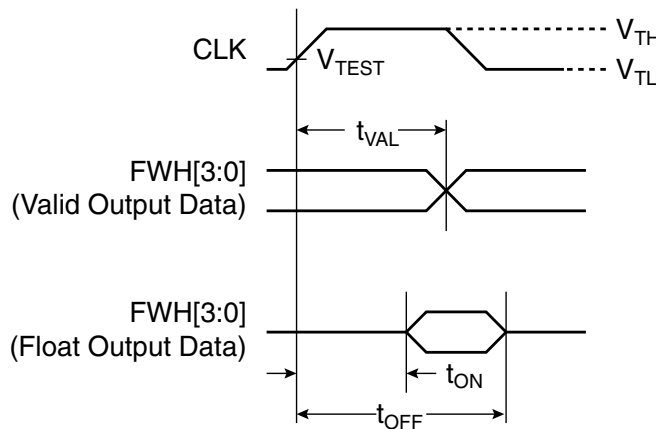

### 17. Input Timing Parameters

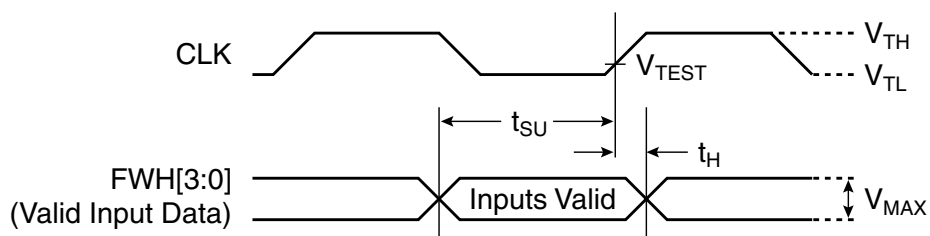

## 18. Interface Measurement Condition Parameters

Symbol	Value	Units
$V_{TH}^{(1)}$	$0.6 V_{CC}$	V
$V_{TL}^{(1)}$	$0.2 V_{CC}$	V
$V_{TEST}$	$0.4 V_{CC}$	V
$V_{MAX}^{(1)}$	$0.4 V_{CC}$	V
Input Signal Edge Rate	1 V/ns	

Note: 1. The input test environment is done with  $0.1 V_{CC}$  of overdrive over  $V_{IH}$  and  $V_{IL}$ . Timing parameters must be met with no more overdrive than this.  $V_{MAX}$  specifies the maximum peak-to-peak waveform allowed for measuring the input timing. Production testing may use different voltage values, but must correlate results back to these parameters.

## 19. Reset Operations

Symbol	Parameter	Min	Max	Unit
$t_{PLPH}^{(1)}$	$\overline{RST}$ or $\overline{INIT}$ Pulse Low Time (If $\overline{RST}$ or $\overline{INIT}$ is tied to $V_{CC}$ , this specification is not applicable)	100		ns

Note: 1. A reset latency of 20  $\mu$ s will occur if a reset procedure is performed during a programming or erase operation.

## 20. AC Waveform for Reset Operation

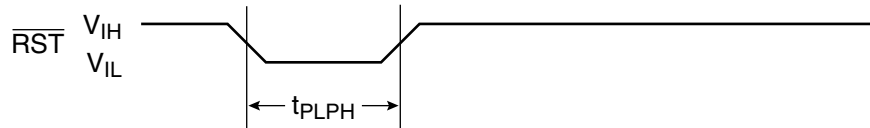

## 21. Sector Programming Times

Parameter	3.3V $V_{PP}$		12V $V_{PP}$		Unit
	Typ <sup>(1)</sup>	Max	Typ <sup>(1)</sup>	Max	
Byte Program Time <sup>(2)</sup>	30.0	300	12.0	125	$\mu$ s
Sector Program Time <sup>(2)</sup>	2.0	20.0	0.8	8.0	sec
Sector Erase Time <sup>(2)</sup>	0.8	1.0	0.35	0.6	sec

Notes: 1. Typical values measured at  $T_A = +25^\circ\text{C}$  and nominal voltages.  
2. Excludes system-level overhead.

## 22. Electrical Characteristics in A/A Mux Mode

Certain specifications differ from the previous sections, when programming in A/A Mux Mode. The following subsections provide this data. Any information that is not shown here is not specific to A/A Mux Mode and uses the FWH Mode specifications.

When the  $V_{PP}$  voltage is  $\leq V_{PPLK}$ , read operations from memory or reading the Product ID are enabled, but programming and erase functions are disabled. Placing  $V_{PPH1/2}$  on  $V_{PP}$  enables successful sector erase and program operations.

## 23. A/A Mux Mode Interface DC Input/Output Specifications

Symbol	Parameter	Conditions	Min	Max	Unit
$V_{IH}^{(3)}$	Input High Voltage		$0.5 V_{CC}$	$V_{CC} + 0.5$	V
$V_{IL}^{(3)}$	Input Low Voltage		-0.5	0.8	V
$I_{IL}^{(4)}$	Input Leakage Current	$V_{CC} = V_{CC} \text{ max,}$ $V_{out} = V_{CC} \text{ or GND}$		$\pm 10$	$\mu\text{A}$
$V_{OH}$	Output High Voltage	$V_{CC} = V_{CC} \text{ min, } I_{OH} = -2.5 \text{ mA}$ $V_{CC} = V_{CC} \text{ min, } I_{OH} = -100 \mu\text{A}$	$0.85 V_{CC} \text{ min}$ $V_{CC} = 0.4$		V V
$V_{OL}$	Output Low Voltage	$V_{CC} = V_{CC} \text{ min, } I_{OL} = 2 \text{ mA}$		0.4	V
$C_{IN}$	Input Pin Capacitance			13	pF
$C_{CLK}$	CLK Pin Capacitance		3	12	pF
$L_{PIN}^{(2)}$	Recommended Pin Inductance			20	nH

- Notes:
- Input leakage currents include high-Z output leakage for all bi-directional buffers with tri-state outputs.
  - Refer to PCI spec.
  - Inputs are not "5-volt safe."
  - $I_{IL}$  may be changed on IC and ID pins (up to 200  $\mu\text{A}$ ) if pulled against internal pull-downs. Refer to the pin descriptions.

## 24. Reset Operations

Symbol	Parameter	Min	Max	Unit
$t_{PLPH}$	$\overline{\text{RST}}$ Pulse Low Time (If $\overline{\text{RST}}$ is tied to $V_{CC}$ , this specification is not applicable.)	100		ns
$t_{PLRH}$	$\overline{\text{RST}}$ Low to Reset during Sector Erase or Program <sup>(1)(2)</sup>		20	$\mu\text{s}$

- Notes:
- If  $\overline{\text{RST}}$  is asserted when the WSM is not busy ( $\text{RY}/\overline{\text{BY}} = 1$ ), the reset will complete within 100 ns.
  - A reset time,  $t_{PHAV}$ , is required from the latter of  $\text{RY}/\overline{\text{BY}}$  or  $\overline{\text{RST}}$  going high until outputs are valid.

## 25. AC Waveforms for Reset Operations

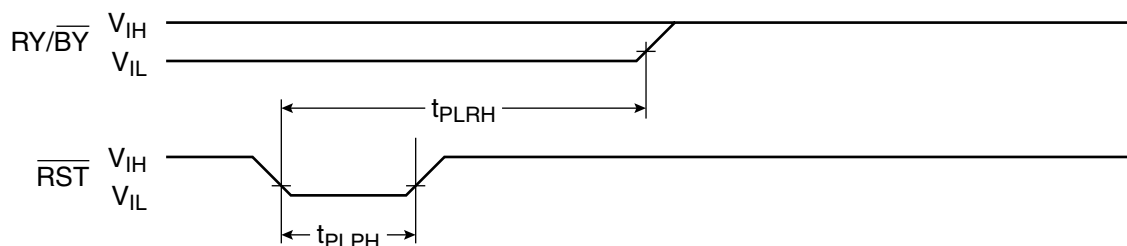

## 26. A/A Mux Read-only Operations<sup>(1)(2)</sup>

Symbol	Parameter	Min	Max	Units
$t_{AVAV}$	Read Cycle Time	250		ns
$t_{AVCL}$	Row Address Setup to $R/\bar{C}$ Low	50		ns
$t_{CLAX}$	Row Address Hold from $R/\bar{C}$ Low	50		ns
$t_{AVCH}$	Column Address Setup to $R/\bar{C}$ High	50		ns
$t_{CHAX}$	Column Address Hold from $R/\bar{C}$ High	50		ns
$t_{CHQV}$	$R/\bar{C}$ High to Output Delay <sup>(2)</sup>		150	ns
$t_{GLQV}$	$\overline{OE}$ Low to Output Delay <sup>(2)</sup>		50	ns
$t_{PHAV}$	$\overline{RST}$ High to Row Address Setup	1		$\mu$ s
$t_{GLQX}$	$\overline{OE}$ Low to Output in Low-Z	0		ns
$t_{GHQZ}$	$\overline{OE}$ High to Output in High-Z		50	ns
$t_{QXGH}$	Output Hold from $\overline{OE}$ High	0		ns

- Note:
1. See AC Input/Output Reference Waveform for maximum allowable input slew rate.
  2.  $\overline{OE}$  may be delayed up to  $t_{CHQV} - t_{GLQV}$  after the rising edge of  $R/\bar{C}$  without impact on  $t_{CHQV}$ .
  3.  $T_C = 0^\circ\text{C}$  to  $+85^\circ\text{C}$ ,  $3.3\text{V} + 0.3\text{V } V_{CC}$ .

## 27. A/A Mux Read Timing Diagram

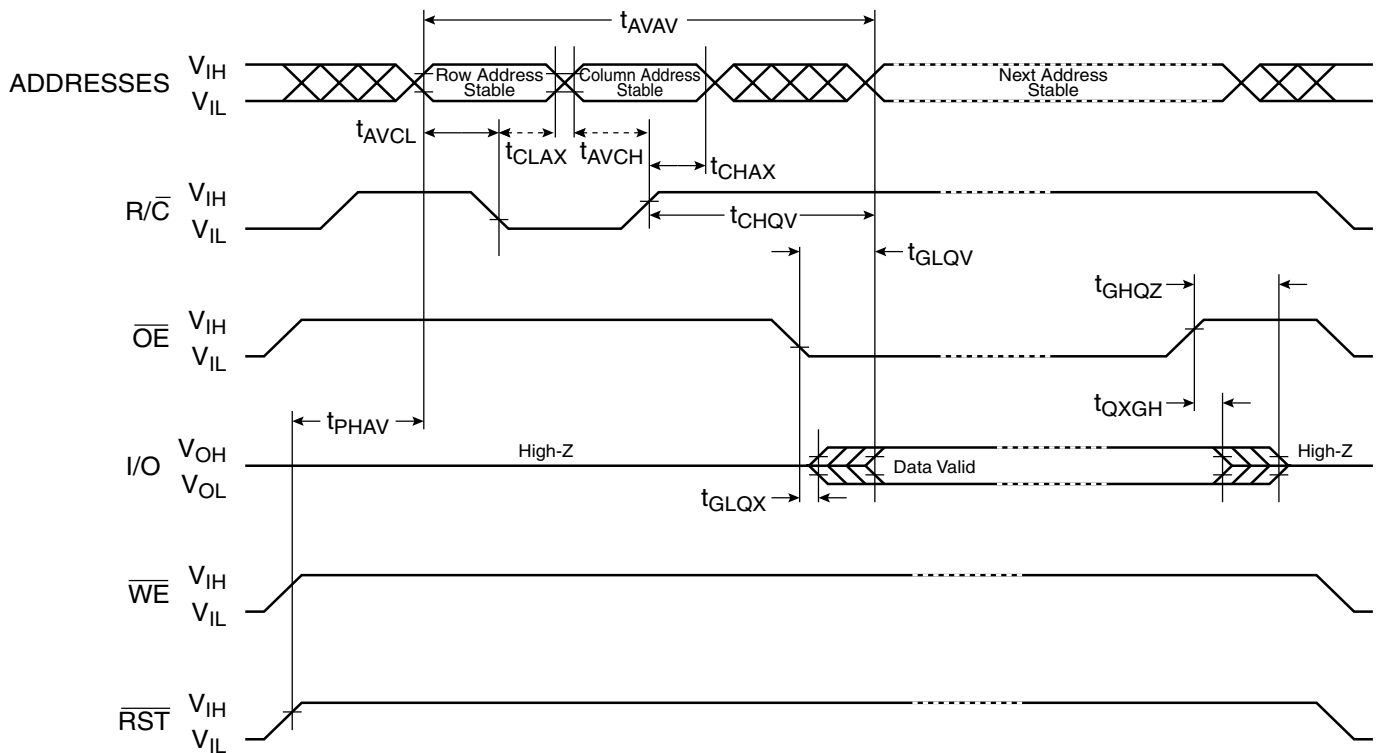

28. A/A Mux Write Operations<sup>(1)(2)</sup>

Symbol	Parameter	Min	Max	Units
$t_{PHWL}$	$\overline{RP}$ High Recovery to $\overline{WE}$ Low	1		$\mu s$
$t_{WLWH}$	Write Pulse Width Low	100		ns
$t_{DVWH}$	Data Setup to $\overline{WE}$ High <sup>(1)</sup>	50		ns
$t_{WHDX}$	Data Hold from $\overline{WE}$ High <sup>(1)</sup>	8		ns
$t_{AVCL}$	Row Address Setup to $R/\overline{C}$ Low <sup>(1)</sup>	50		ns
$t_{CLAX}$	Row Address Hold from $R/\overline{C}$ Low <sup>(1)</sup>	50		ns
$t_{AVCH}$	Column Address Setup to $R/\overline{C}$ High <sup>(1)</sup>	50		ns
$t_{CHAX}$	Column Address Hold from $R/\overline{C}$ High <sup>(1)</sup>	50		ns
$t_{WHWL}$	Write Pulse Width High	100		ns
$t_{CHWH}$	$R/\overline{C}$ High Setup to $\overline{WE}$ High	50		ns
$t_{VPWH}$	$V_{PP1,2}$ Setup to $\overline{WE}$ High	100		ns
$t_{WHGL}$	Write Recovery before Read		150	ns
$t_{WHRL}$	$\overline{WE}$ High to $RY/\overline{BY}$ Going Low	0		ns
$t_{QVVL}$	$V_{PP1,2}$ Hold from Valid SRD, $RY/\overline{BY}$ High	0		ns

- Notes: 1. Refer to "A/A Mux Read-only Operations" for valid  $A_{IN}$  and  $D_{IN}$  for sector erase or program, or other commands.  
 2.  $T_C = 0^\circ C$  to  $+85^\circ C$ ,  $3.3V \pm 0.3V V_{CC}$ .

## 28.1 A/A Mux Write Timing Diagram

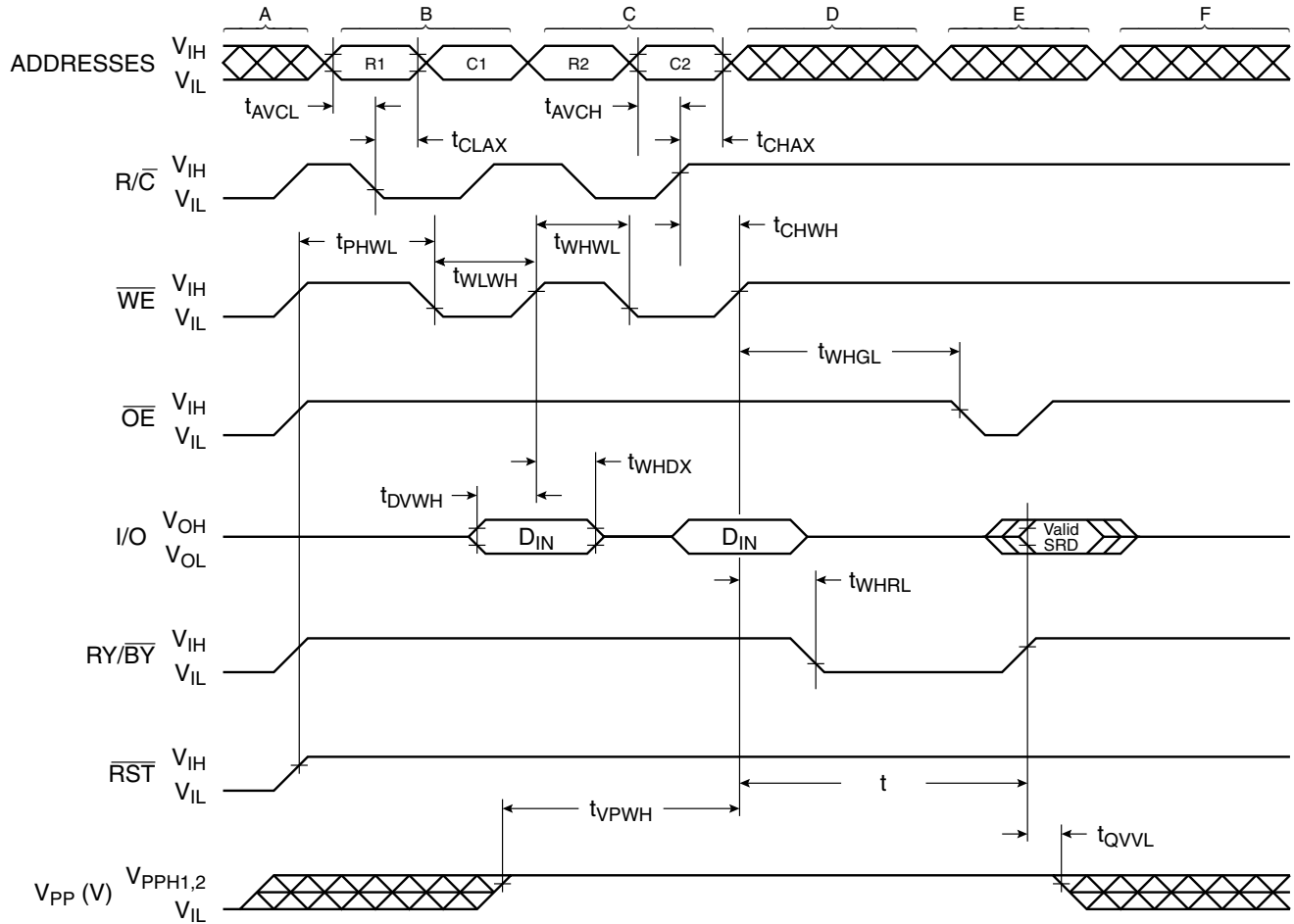

### NOTES

- A =  $V_{CC}$  power-up and standby
- B = Write sector erase or program setup
- C = Write sector erase confirm or valid address and data
- D = Automated erase or program delay
- E = Read status register data
- F = Ready to write another command

**29. Ordering Information**

**29.1 Standard Package**

$I_{CC}$ (mA)		Ordering Code	Package	Operation Range
Active	Standby			
67	0.10	AT49LW080-33JC AT49LW080-33TC	32J 40T	Extended Commercial (0° to 85°C)

**29.2 Green Package Option (Pb/Halide-free)**

$I_{CC}$ (mA)		Ordering Code	Package	Operation Range
Active	Standby			
67	0.10	AT49LW080-33JX	32J	Extended Commercial (0° to 85°C)

Package Type	
<b>32J</b>	32-lead, Plastic J-leaded Chip Carrier Package (PLCC)
<b>40T</b>	40-lead, Thin Small Outline Package (TSOP)

## 30. Packaging Information

### 30.1 32J – PLCC

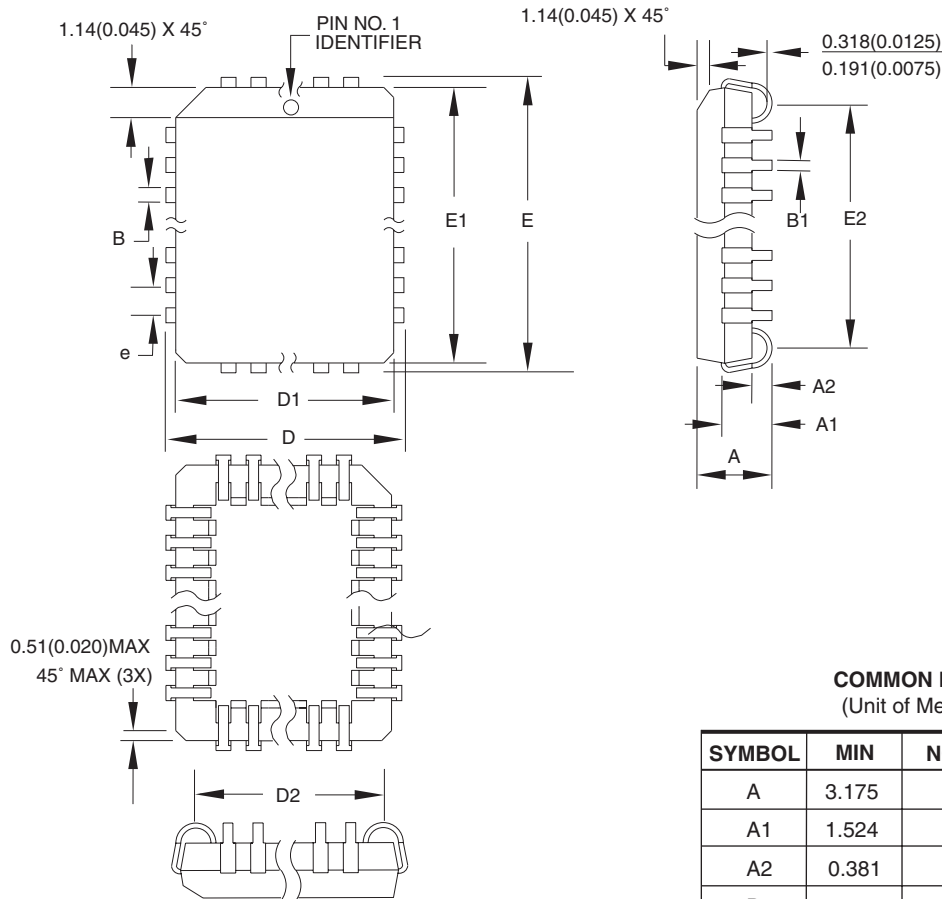

**COMMON DIMENSIONS**  
(Unit of Measure = mm)

SYMBOL	MIN	NOM	MAX	NOTE
A	3.175	-	3.556	
A1	1.524	-	2.413	
A2	0.381	-	-	
D	12.319	-	12.573	
D1	11.354	-	11.506	Note 2
D2	9.906	-	10.922	
E	14.859	-	15.113	
E1	13.894	-	14.046	Note 2
E2	12.471	-	13.487	
B	0.660	-	0.813	
B1	0.330	-	0.533	
e	1.270 TYP			

- Notes:
1. This package conforms to JEDEC reference MS-016, Variation AE.
  2. Dimensions D1 and E1 do not include mold protrusion. Allowable protrusion is .010" (0.254 mm) per side. Dimension D1 and E1 include mold mismatch and are measured at the extreme material condition at the upper or lower parting line.
  3. Lead coplanarity is 0.004" (0.102 mm) maximum.

10/04/01



2325 Orchard Parkway  
San Jose, CA 95131

**TITLE**

**32J, 32-lead, Plastic J-leaded Chip Carrier (PLCC)**

**DRAWING NO.**

32J

**REV.**

B



30.2 40T – TSOP

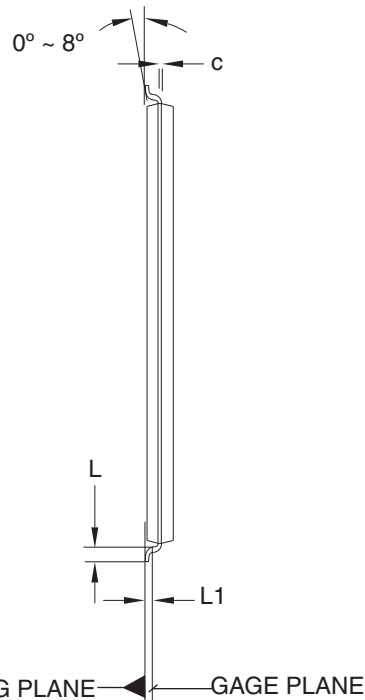
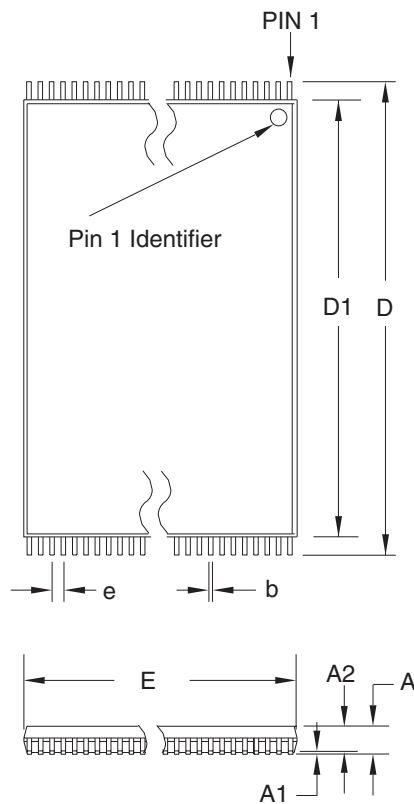

COMMON DIMENSIONS  
(Unit of Measure = mm)

SYMBOL	MIN	NOM	MAX	NOTE
A	–	–	1.20	
A1	0.05	–	0.15	
A2	0.95	1.00	1.05	
D	19.80	20.00	20.20	
D1	18.30	18.40	18.50	Note 2
E	9.90	10.00	10.10	Note 2
L	0.50	0.60	0.70	
L1	0.25 BASIC			
b	0.17	0.22	0.27	
c	0.10	–	0.21	
e	0.50 BASIC			

- Notes:
1. This package conforms to JEDEC reference MO-142, Variation CD.
  2. Dimensions D1 and E do not include mold protrusion. Allowable protrusion on E is 0.15 mm per side and on D1 is 0.25 mm per side.
  3. Lead coplanarity is 0.10 mm maximum.

10/18/01



2325 Orchard Parkway  
San Jose, CA 95131

TITLE

40T, 40-lead (10 x 20 mm Package) Plastic Thin Small Outline Package, Type I (TSOP)

DRAWING NO.

40T

REV.

B





## Atmel Corporation

2325 Orchard Parkway  
San Jose, CA 95131, USA  
Tel: 1(408) 441-0311  
Fax: 1(408) 487-2600

## Regional Headquarters

### Europe

Atmel Sarl  
Route des Arsenalux 41  
Case Postale 80  
CH-1705 Fribourg  
Switzerland  
Tel: (41) 26-426-5555  
Fax: (41) 26-426-5500

### Asia

Room 1219  
Chinachem Golden Plaza  
77 Mody Road Tsimshatsui  
East Kowloon  
Hong Kong  
Tel: (852) 2721-9778  
Fax: (852) 2722-1369

### Japan

9F, Tonetsu Shinkawa Bldg.  
1-24-8 Shinkawa  
Chuo-ku, Tokyo 104-0033  
Japan  
Tel: (81) 3-3523-3551  
Fax: (81) 3-3523-7581

## Atmel Operations

### Memory

2325 Orchard Parkway  
San Jose, CA 95131, USA  
Tel: 1(408) 441-0311  
Fax: 1(408) 436-4314

### Microcontrollers

2325 Orchard Parkway  
San Jose, CA 95131, USA  
Tel: 1(408) 441-0311  
Fax: 1(408) 436-4314

La Chantrerie  
BP 70602  
44306 Nantes Cedex 3, France  
Tel: (33) 2-40-18-18-18  
Fax: (33) 2-40-18-19-60

### ASIC/ASSP/Smart Cards

Zone Industrielle  
13106 Rousset Cedex, France  
Tel: (33) 4-42-53-60-00  
Fax: (33) 4-42-53-60-01

1150 East Cheyenne Mtn. Blvd.  
Colorado Springs, CO 80906, USA  
Tel: 1(719) 576-3300  
Fax: 1(719) 540-1759

Scottish Enterprise Technology Park  
Maxwell Building  
East Kilbride G75 0QR, Scotland  
Tel: (44) 1355-803-000  
Fax: (44) 1355-242-743

### RF/Automotive

Theresienstrasse 2  
Postfach 3535  
74025 Heilbronn, Germany  
Tel: (49) 71-31-67-0  
Fax: (49) 71-31-67-2340

1150 East Cheyenne Mtn. Blvd.  
Colorado Springs, CO 80906, USA  
Tel: 1(719) 576-3300  
Fax: 1(719) 540-1759

### Biometrics/Imaging/Hi-Rel MPU/ High Speed Converters/RF Datacom

Avenue de Rochepleine  
BP 123  
38521 Saint-Egreve Cedex, France  
Tel: (33) 4-76-58-30-00  
Fax: (33) 4-76-58-34-80

---

## Literature Requests

[www.atmel.com/literature](http://www.atmel.com/literature)

**Disclaimer:** The information in this document is provided in connection with Atmel products. No license, express or implied, by estoppel or otherwise, to any intellectual property right is granted by this document or in connection with the sale of Atmel products. **EXCEPT AS SET FORTH IN ATMEL'S TERMS AND CONDITIONS OF SALE LOCATED ON ATMEL'S WEB SITE, ATMEL ASSUMES NO LIABILITY WHATSOEVER AND DISCLAIMS ANY EXPRESS, IMPLIED OR STATUTORY WARRANTY RELATING TO ITS PRODUCTS INCLUDING, BUT NOT LIMITED TO, THE IMPLIED WARRANTY OF MERCHANTABILITY, FITNESS FOR A PARTICULAR PURPOSE, OR NON-INFRINGEMENT. IN NO EVENT SHALL ATMEL BE LIABLE FOR ANY DIRECT, INDIRECT, CONSEQUENTIAL, PUNITIVE, SPECIAL OR INCIDENTAL DAMAGES (INCLUDING, WITHOUT LIMITATION, DAMAGES FOR LOSS OF PROFITS, BUSINESS INTERRUPTION, OR LOSS OF INFORMATION) ARISING OUT OF THE USE OR INABILITY TO USE THIS DOCUMENT, EVEN IF ATMEL HAS BEEN ADVISED OF THE POSSIBILITY OF SUCH DAMAGES.** Atmel makes no representations or warranties with respect to the accuracy or completeness of the contents of this document and reserves the right to make changes to specifications and product descriptions at any time without notice. Atmel does not make any commitment to update the information contained herein. Atmel's products are not intended, authorized, or warranted for use as components in applications intended to support or sustain life.

© Atmel Corporation 2005. All rights reserved. Atmel®, logo and combinations thereof, and others, are registered trademarks, and Everywhere You Are<sup>SM</sup> and others are the trademarks of Atmel Corporation or its subsidiaries. Other terms and product names may be trademarks of others.



Printed on recycled paper.

1966G-FLASH-3/05

/xM