

# Triple Port USB Power Distribution Switch and Over-Current Protection

## General Description

The LM3543 is a triple high-side power switch that is an excellent choice for use in Root, Self-Powered and Bus-Powered USB (Universal Serial Bus) Hubs. Independent port enables, flag signals to alert USB controllers of error conditions, controlled start-up in hot-plug events, and short circuit protection all satisfy USB requirements.

The LM3543 accepts input voltages between 2.7V and 5.5V. The Enable logic inputs, available in active-high and active-low versions, can be powered off any voltage in the 2.7V to 5.5V range. The LM3543 limits the continuous current through a single port to 1.25A (max.) when it is shorted to ground.

The low on-state resistance of the LM3543 switches ensures the LM3543 will satisfy USB voltage drop requirements, even when current through a switch reaches 500 mA. Thus, High-Powered USB Functions, Low-Powered USB Functions, and Bus-Powered USB Hubs can all be powered off a Root or Self-Powered USB Hub containing the LM3543.

Added features of the LM3543 include current foldback to reduce power consumption in current overload conditions, thermal shutdown to prevent device failure caused by high-current overheating, and undervoltage lockout to keep switches from operating if the input voltage is below acceptable levels.

## Features

- Compatible with USB1.1 and USB 2.0
- 90mΩ (typ.) High-Side MOSFET Switch
- 500mA Continuous Current per Port
- 7 ms Fault Flag Delay Filters Hot-Plug Events
- Industry Standard Pin Order
- Short Circuit Protection with Power-Saving Current Foldback
- Thermal Shutdown Protection
- Undervoltage Lockout
- Recognized by UL and Nemko
- Input Voltage Range: 2.7V to 5.5V
- 5 μA Maximum Standby Supply Current
- 16-Pin SOIC Package
- Ambient Temperature Range: -40°C to 85°C

## Applications

- USB Root, Self-Powered, and Bus-Powered Hubs
- USB Devices such as Monitors and Printers
- General Purpose High Side Switch Applications



## Functional Diagram

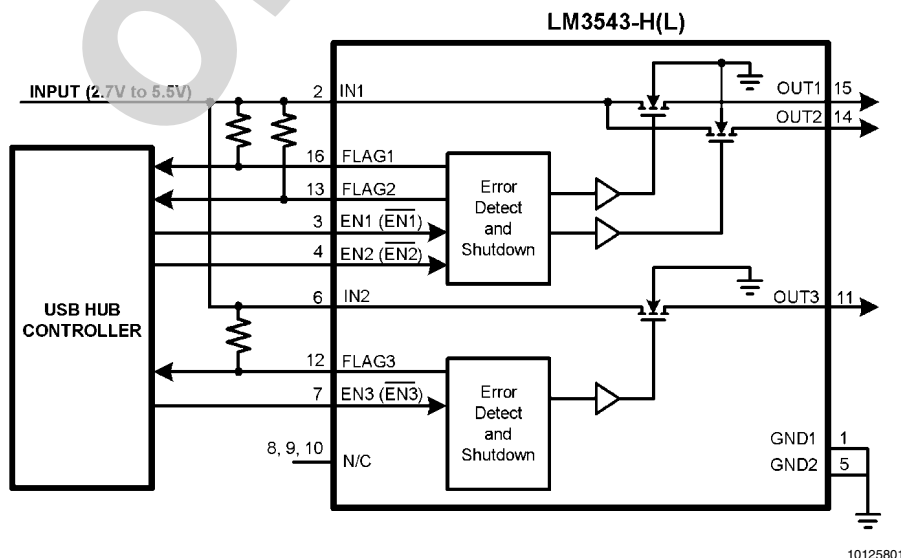

## Connection Diagrams

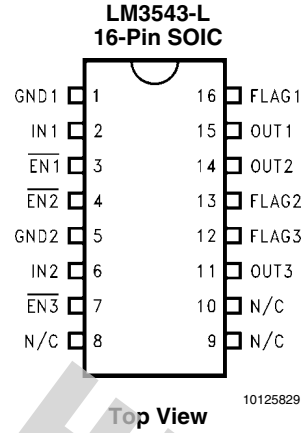
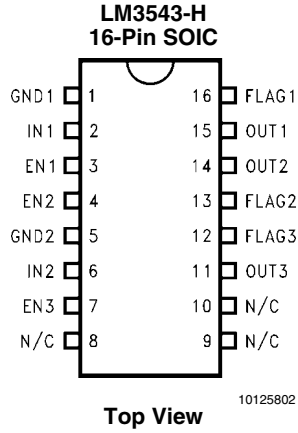

## Ordering Information

Part Number	Enable, Delivery Option	Package Type
LM3543M-H	Active High Enable	SO-16 NS Package Number M16A
LM3543M-L	Active Low Enable	
LM3543MX-H	Active High Enable, 2500 units per reel	
LM3543MX-L	Active Low Enable, 2500 units per reel	

## Typical Application Circuit

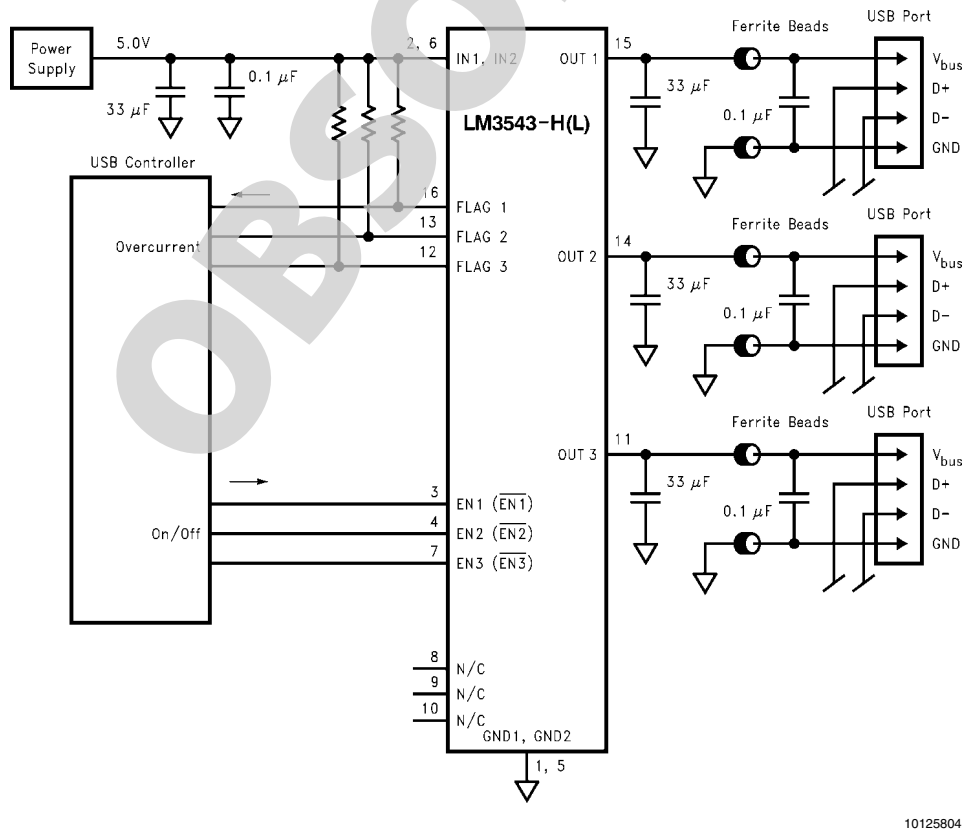

FIGURE 1. The LM3543 used in a Self-Powered or Root USB Hub

## Absolute Maximum Ratings *(Note 1)*

If Military/Aerospace specified devices are required, please contact the National Semiconductor Sales Office/Distributors for availability and specifications.

Voltage at IN <sub>x</sub> and OUT <sub>x</sub> pins	-0.3V to 6V
Voltage at EN <sub>x</sub> ( $\overline{\text{EN}}_x$ ) and FLAG <sub>x</sub> pins	-0.3V to 5.5V
Power Dissipation <i>(Note 2)</i>	Internally Limited

Maximum Junction Temperature	150°C
Storage Temperature Range	-65°C to 150°C

Lead Temperature Range (Soldering, 5 sec.) 260°C

ESD Rating *(Note 3)* 2 kV

## Operating Ratings

Supply Voltage Range	2.7V to 5.5V
Continuous Output Current Range (Each Output)	0 mA to 500 mA
Junction Temperature Range	-40°C to 125°C

## DC Electrical Characteristics

Limits in standard typeface are for T<sub>J</sub> = 25°C, and limits in **boldface** type apply over the full operating temperature range. Unless otherwise specified: V<sub>IN</sub> = 5.0V, EN<sub>x</sub> = V<sub>IN</sub> (LM3543-H) or  $\overline{\text{EN}}_x = 0\text{V}$  (LM3543-L).

Symbol	Parameter	Conditions	Min	Typ	Max	Units
R <sub>ON</sub>	On Resistance	V <sub>IN</sub> = 5V, I <sub>OUTX</sub> = 0.5A		90	125	mΩ
		V <sub>IN</sub> = 3.3V, I <sub>OUTX</sub> = 0.5A		95	130	
I <sub>OUT</sub>	OUT <sub>x</sub> Continuous Output Current	3.0V ≤ V <sub>IN</sub> ≤ 5.5V	<b>0.5</b>			A
I <sub>LEAK-OUT</sub>	OUT <sub>x</sub> Leakage Current	EN <sub>x</sub> = 0 ( $\overline{\text{EN}}_x = V_{IN}$ ); T <sub>J</sub> = 25°C		0.01	1	μA
		EN <sub>x</sub> = 0 ( $\overline{\text{EN}}_x = V_{IN}$ ); -40 ≤ T <sub>J</sub> ≤ 85°C			<b>10</b>	μA
I <sub>SC</sub>	OUT <sub>x</sub> Short-Circuit Current <i>(Note 4)</i>	OUT <sub>x</sub> Connected to GND		0.8	1.25	A
OC <sub>THRESH</sub>	Overcurrent Threshold			2.0	3.2	A
V <sub>L-FLAG</sub>	FLAG <sub>x</sub> Output-Low Voltage	I(FLAG <sub>x</sub> ) = 10 mA		0.1	<b>0.3</b>	V
I <sub>LEAK-FLAG</sub>	FLAG <sub>x</sub> Leakage Current	2.7 ≤ V <sub>FLAG</sub> ≤ 5.5V		0.2	1	μA
I <sub>LEAK-EN</sub>	EN <sub>x</sub> Input Leakage Current	EN <sub>x</sub> / $\overline{\text{EN}}_x$ = 0V or EN <sub>x</sub> / $\overline{\text{EN}}_x$ = V <sub>IN</sub>	<b>-0.5</b>		<b>0.5</b>	μA
V <sub>IH</sub>	EN/ $\overline{\text{EN}}$ Input Logic High	2.7V ≤ V <sub>IN</sub> ≤ 5.5V	2.4			V
V <sub>IL</sub>	EN/ $\overline{\text{EN}}$ Input Logic Low	4.5V ≤ V <sub>IN</sub> ≤ 5.5V			0.8	V
		2.7V ≤ V <sub>IN</sub> ≤ 4.5V			0.4	V
V <sub>UVLO</sub>	Under-Voltage Lockout Threshold			1.8		V
I <sub>DDON</sub>	Operational Supply Current	EN <sub>x</sub> = V <sub>IN</sub> ( $\overline{\text{EN}}_x = 0$ ); T <sub>J</sub> = 25°C		375	600	μA
		EN <sub>x</sub> = V <sub>IN</sub> ( $\overline{\text{EN}}_x = 0$ ); -40°C ≤ T <sub>J</sub> ≤ 125°C			<b>800</b>	μA
I <sub>DDOFF</sub>	Shutdown Supply Current	EN <sub>x</sub> = 0 ( $\overline{\text{EN}}_x = V_{IN}$ ); T <sub>J</sub> = 25°C			1	μA
		-40°C ≤ T <sub>J</sub> ≤ 125°C			<b>5</b>	μA

**Note 1:** Absolute Maximum Ratings indicate limits beyond which damage to the device may occur. Electrical specifications do not apply when operating the device beyond its rated operating conditions.

**Note 2:** The maximum allowable power dissipation is a function of the Maximum Junction Temperature (T<sub>JMAX</sub>), Junction to Ambient Thermal Resistance (θ<sub>JA</sub>), and the Ambient Temperature (T<sub>A</sub>). The LM3543 in the 16-pin SOIC package has a T<sub>JMAX</sub> of 150°C and a θ<sub>JA</sub> of 130°C/W. The maximum allowable power dissipation at any temperature is P<sub>MAX</sub> = (T<sub>JMAX</sub> - T<sub>A</sub>)/θ<sub>JA</sub>. Exceeding the maximum allowable power dissipation will cause excessive die temperature, and the part will go into thermal shutdown.

**Note 3:** The Human body model is a 100 pF capacitor discharged through a 1.5 kΩ resistor into each pin.

**Note 4:** Thermal Shutdown will protect the device from permanent damage.

## AC Electrical Characteristics

Limits are for  $T_J = 25^\circ\text{C}$  and  $V_{IN} = 5.0\text{V}$ .

Symbol	Parameter	Conditions	Min	Typ	Max	Units
$t_r$	OUT <sub>x</sub> Rise Time ( <i>Note 5</i> )	$C_L = 33\ \mu\text{F}$ , $I_{LOAD} = 500\text{mA}$		1.5		ms
$t_f$	OUT <sub>x</sub> Fall Time ( <i>Note 6</i> )	$C_L = 33\ \mu\text{F}$ , $I_{LOAD} = 500\text{mA}$		0.9		ms
$t_{ON}$	Turn-on Delay ( <i>Note 7</i> )	$C_L = 33\ \mu\text{F}$ , $I_{LOAD} = 500\text{mA}$		2.9		ms
$t_{OFF}$	Turn-off Delay ( <i>Note 8</i> )	$C_L = 33\ \mu\text{F}$ , $I_{LOAD} = 500\text{mA}$		0.7		ms
$t_F$	Flag Delay ( <i>Note 9</i> )	$I_{FLAG} = 10\ \text{mA}$		7		ms

**Note 5:** Time for OUT<sub>x</sub> to rise from 10% to 90% of its enabled steady-state value after EN<sub>x</sub> ( $\overline{\text{EN}}_x$ ) is asserted.

**Note 6:** Time for OUT<sub>x</sub> to fall from 10% to 90% of its enabled steady-state value after EN<sub>x</sub> ( $\overline{\text{EN}}_x$ ) is deasserted.

**Note 7:** Time between EN<sub>x</sub> rising through  $V_{IH}$  ( $\overline{\text{EN}}_x$  falling through  $V_{IL}$ ) and OUT<sub>x</sub> rising through 90% of its enabled steady-state voltage.

**Note 8:** Time between EN<sub>x</sub> falling through  $V_{IL}$  ( $\overline{\text{EN}}_x$  rising through  $V_{IH}$ ) and OUT<sub>x</sub> falling through 10% of its enabled steady-state voltage.

**Note 9:** Time between EN<sub>x</sub> rising through  $V_{IN}$  ( $\overline{\text{EN}}_x$  falling through  $V_{IN}$ ) and FLAG<sub>x</sub> falling through 0.3V when OUT<sub>x</sub> is connected to GND.

## Pin Descriptions

Pin Number	Pin Name	Pin Function
2, 6	IN 1, 2	Supply Inputs: These pins are the inputs to the power switches and the supply input for the IC. In most applications they are connected together externally and to a single input voltage supply.
1, 5	GND 1, 2	Grounds: Must be connected together and to a common ground.
15, 14, 11	OUT 1, 2, 3	Switch Outputs: These pins are the outputs of the high side switches.
3, 4, 7	LM3543-H: EN 1, 2, 3 LM3543-L: $\overline{\text{EN}}$ 1, 2, 3	Enable (Inputs): Active-high (or active-low) logic enable inputs.
16, 13, 12	FLAG 1, 2, 3	Fault Flag (Outputs): Active-low open drain outputs. Indicates over-current, UVLO or thermal shutdown.
8, 9, 10	N/C	No Internal Connection.

**Typical Performance Characteristics**

$V_{IN} = 5.0$ ,  $I_{OUT\_X} = 500\text{mA}$ ,  $T_A = 25^\circ\text{C}$  unless otherwise specified.

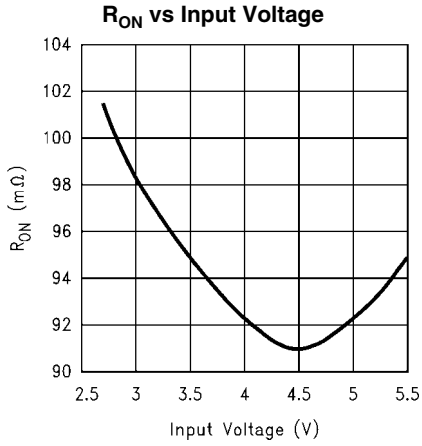

10125805

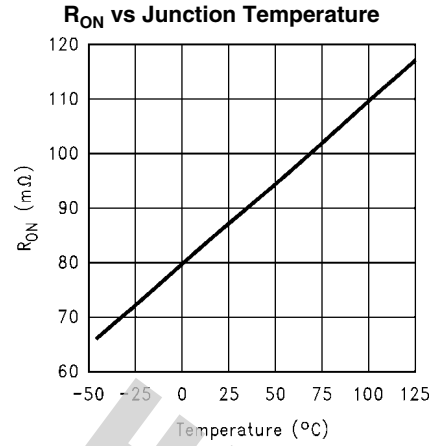

10125806

**Quiescent Current, Output(s) Enabled vs Junction Temperature**

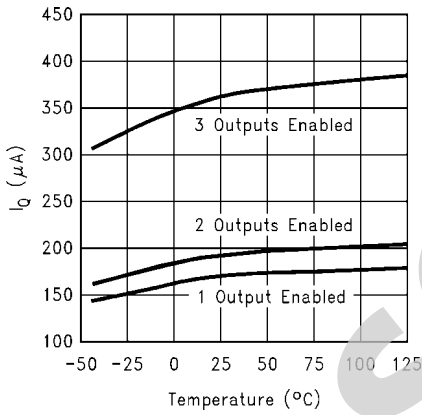

10125807

**Quiescent Current, Output(s) Disabled vs Junction Temperature**

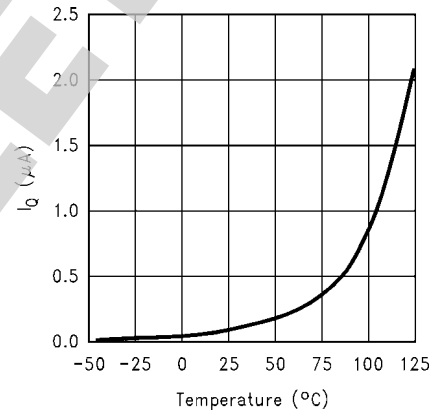

10125808

**Quiescent Current, Output(s) Enabled vs Input Voltage**

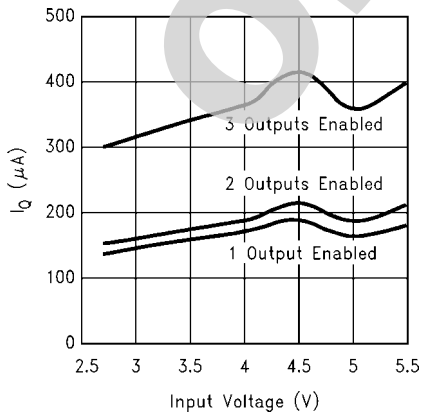

10125809

**Quiescent Current, Output(s) Disabled vs Input Voltage**

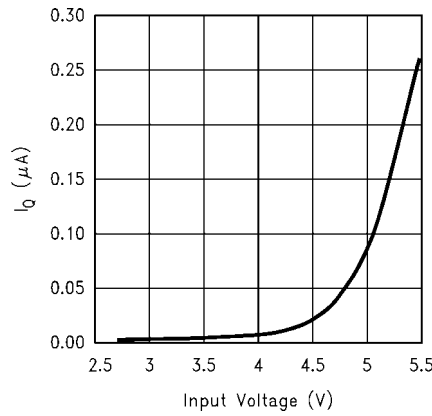

10125810

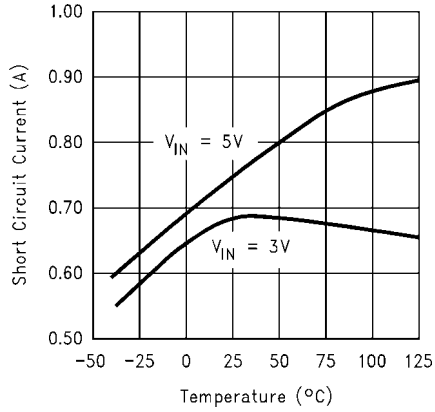
**Short-Circuit Output Current vs Junction Temperature** (Note 10)

10125813

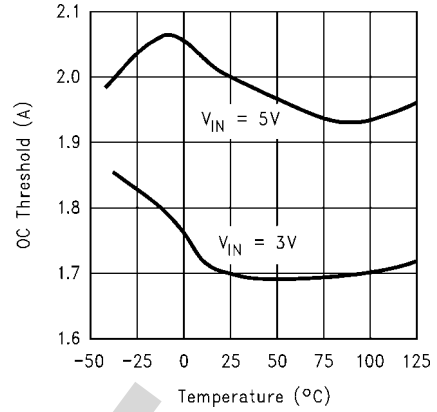
**Over-Current Threshold vs Junction Temperature** (Note 10)

10125814

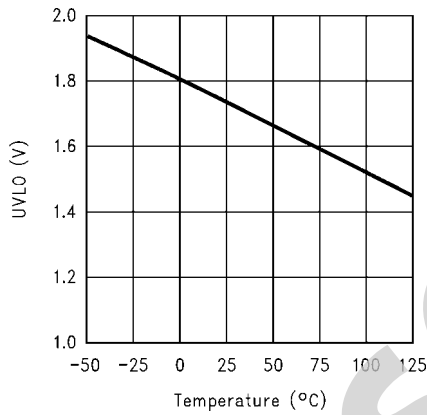
**Under-Voltage Lockout (UVLO) Threshold vs Junction Temperature**

10125815

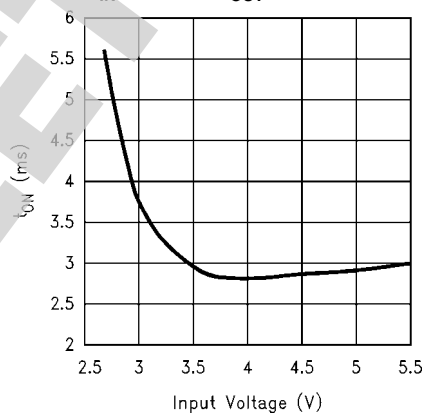
**Turn-On Delay vs Input Voltage** ( $C_{IN} = 33 \mu F$ ,  $C_{OUT} = 33 \mu F$ )

10125811

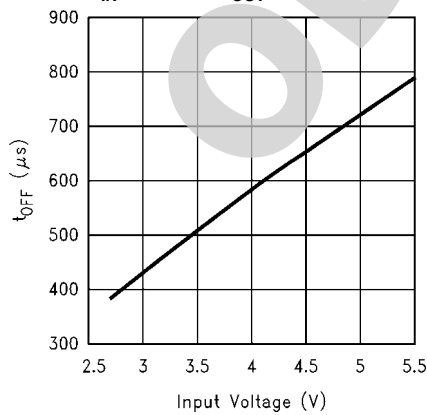
**Turn-Off Delay vs input Voltage** ( $C_{IN} = 33 \mu F$ ,  $C_{OUT} = 33 \mu F$ )

10125812

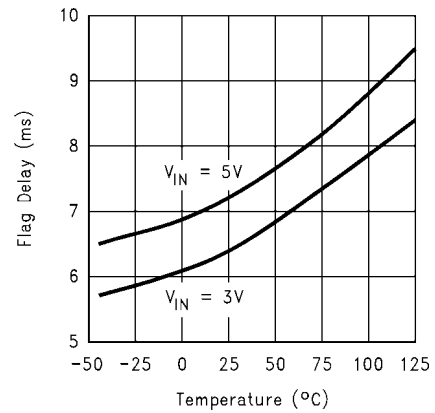
**Fault Flag Delay Time vs Junction Temperature**

10125816

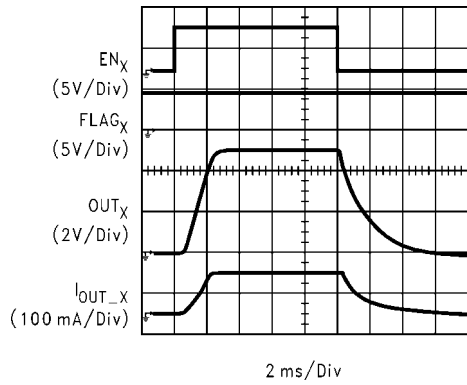
Turn-On/Turn-Off Response with 47 $\Omega$ /33 $\mu$ F Load

10125818

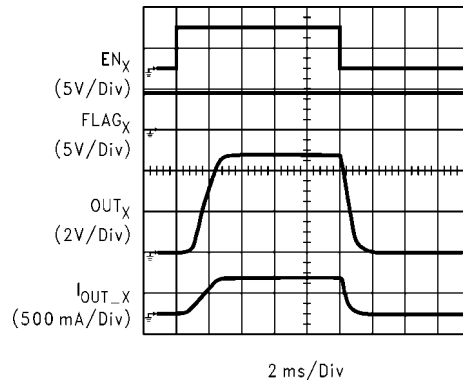
Turn-On/Turn-Off Response with 10 $\Omega$ /33 $\mu$ F Load

10125819

## Enable Into a Short (Note 10)

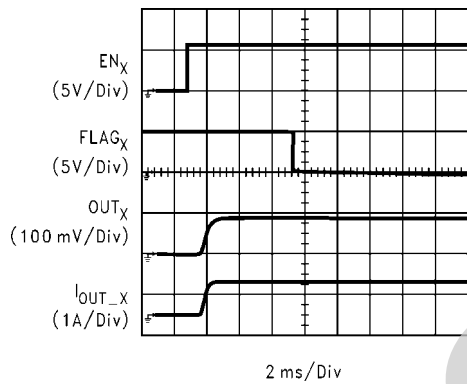

10125820

## Short Connected to Enabled Device (Note 10)

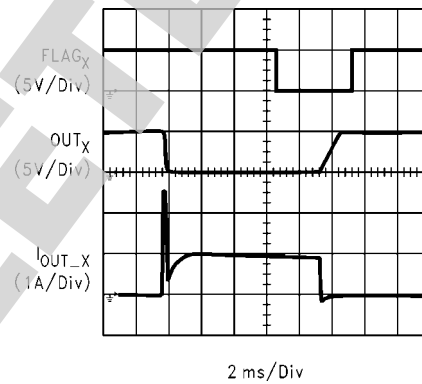

10125821

## Over-Current Response with Ramped Load on OUT1 and Fixed Load on OUT2 (Note 10)

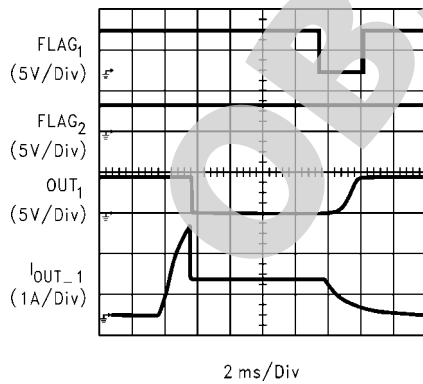

10125822

## Inrush Current to Downstream Device when LM3543 is Enabled (Note 11)

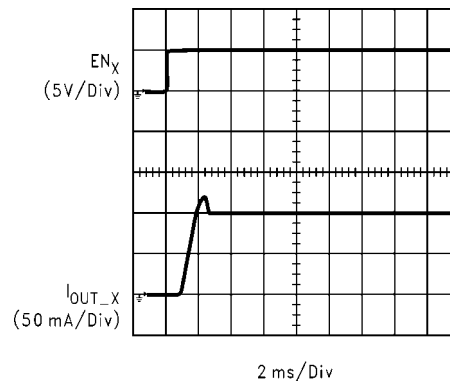

10125823

**Note 10:** Output is shorted to Ground through a 100 m $\Omega$  resistor.

**Note 11:** Load is two capacitors and one resistor in parallel to model an actual USB load condition. The first capacitor has a value of 33  $\mu$ F to model the LM3543 output capacitor. The second capacitor has a value of 10  $\mu$ F to model the maximum allowable input capacitance of the downstream device. The resistor is a 47 $\Omega$  resistor to model the maximum allowable input resistance of the downstream device.

## Functional Descriptions

### POWER SWITCHES

The power switches that comprise the three ports of the LM3543 are N-Channel MOSFETs. They have a typical on-state drain-to-source resistance of 90 mΩ when the input voltage is 5 V. When enabled, each switch will supply a 500 mA minimum current to its load. In the unlikely event that a switch is enabled and the output voltage of that switch is pulled above the input voltage, the bi-directional nature of the switch results in current to flow from the output to the input. When a switch is disabled, current flow through the switch is prevented in both directions.

### CHARGE PUMP AND DRIVER

The gate voltages of the high-side NFET power switches are supplied by an internal charge-pump and driver circuit combination. The charge pump is a low-current switched-capacitor circuit that efficiently generates voltages above the LM3543 input supply. The charge pump output is used to supply a transconductance amplifier driver circuit that controls the gate voltages of the power switches. Rise and fall times on the gates are typically kept between 2 ms and 4 ms to limit large current surges and associated electromagnetic interference (EMI).

### ENABLE ( $EN_x$ or $\overline{EN}_x$ )

The LM3543 comes in two versions: an active-high enable version, LM3543-H, and an active-low enable version, LM3543-L. In the LM3543-H, the  $EN_x$  pins are active-high logic inputs that, when asserted, turn on the associated power supply switch(es). Power supply switches are controlled by the  $\overline{EN}_x$  active-low logic inputs in the LM3543-L. With all three ports disabled on either version of the LM3543, less than 5 μA of supply current is consumed. Both types of enable inputs, active-high and active-low, are TTL and CMOS logic compatible.

### INPUT AND OUTPUT

The power supply to the control circuitry and the drains of the power-switch MOSFETs are connected to the two input pins, IN1 and IN2. These two pins are connected externally in most standard applications. The two ground nodes GND1 and GND2 must be connected externally in all applications.

Pins OUT1, OUT2, and OUT3 are connections to the source nodes of the power-switch MOSFETs. In a typical application circuit, current flows through the switches from IN1 and IN2 to  $OUT_x$  toward the load.

### UNDERVOLTAGE LOCKOUT (UVLO)

Undervoltage Lockout (UVLO) prevents the MOSFET switches from turning on until the input voltage exceeds a typical value of 1.8V.

If the input voltage drops below the UVLO threshold, the MOSFET switches are opened and fault flags are activated. UVLO flags function only when one or more of the ports is enabled. Due to the paired nature of the design, both FLAG1 and FLAG2 will assert if either port1 or port2 is enabled in a UVLO condition.

### CURRENT LIMIT AND FOLDBACK

The current limit circuit is designed to protect the system supply, the LM3543 switches, and the load from potential damage resulting from excessive currents. If a direct short occurs on an output of the LM3543, the input capacitor(s) rapidly discharge through the part, activating current limit circuitry. The threshold for activating current limiting is 2.0A (typ.). Protec-

tion is achieved by momentarily opening the MOSFET switch and then gradually turning it on. Turn-on is halted when the current through the switch reaches the current-limit level of 1.0A (typ.) The current is held at this level until either the excessive load/short is removed or the part overheats and thermal shutdown occurs (see Thermal Shutdown section, below). The fault flag of a switch is asserted whenever the switch is current limiting.

If a port on the LM3543 is enabled into a short condition, the output current of that port will rise to the current-limit level and hold there.

When a port is in a current-limit condition, the LM3543 senses the output voltage on that port and, if it is less than 1.0V (typ.), will reduce the output current through that port. This operation is shown in [Figure 2](#), below. The current reduction, or foldback, reduces power dissipation through the overloaded MOSFET switch. An additional advantage of the foldback feature is the reduction of power required from the source supply when one or more output ports are shorted.

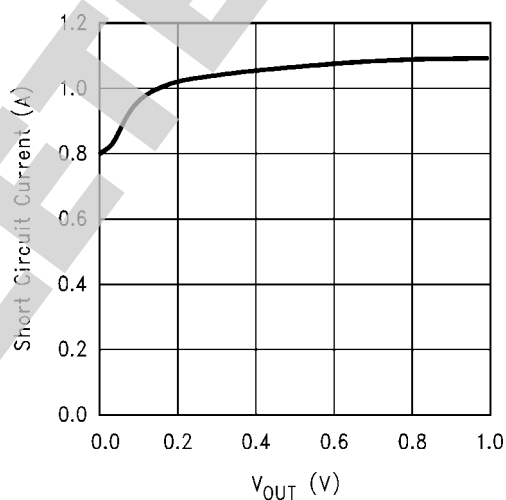

10125817

**FIGURE 2. Short-Circuit Output Current (with Foldback) vs. Output Voltage**

### THERMAL SHUTDOWN

The LM3543 is internally protected against excessive power dissipation by a two-stage thermal protection circuit. If the device temperature rises to approximately 145°C, the thermal shutdown circuitry turns off any switch that is current limited. Non-overloaded switches continue to function normally. If the die temperature rises above 160°C, all switches are turned off and all three fault flag outputs are activated. Hysteresis ensures that a switch turned off by thermal shutdown will not be turned on again until the die temperature is reduced to 135°C. Shorted switches will continue to cycle off and on, due to the rising and falling die temperature, until the short is removed.

The thermal shutdown function is shown graphically in [Figure 3](#) and [Figure 4](#).



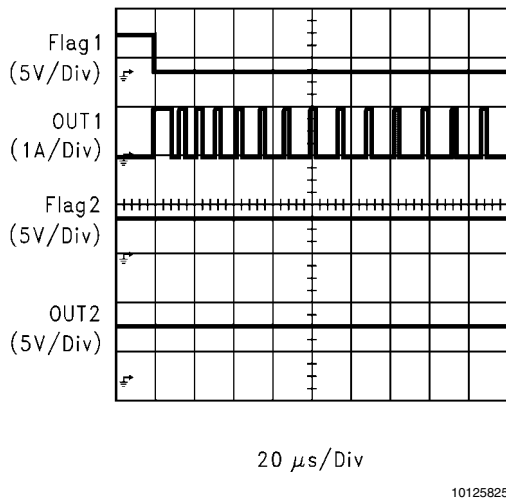

**FIGURE 3. Thermal Shutdown Characteristics when only the First-Stage Thermal-Shutdown Mode is Needed**

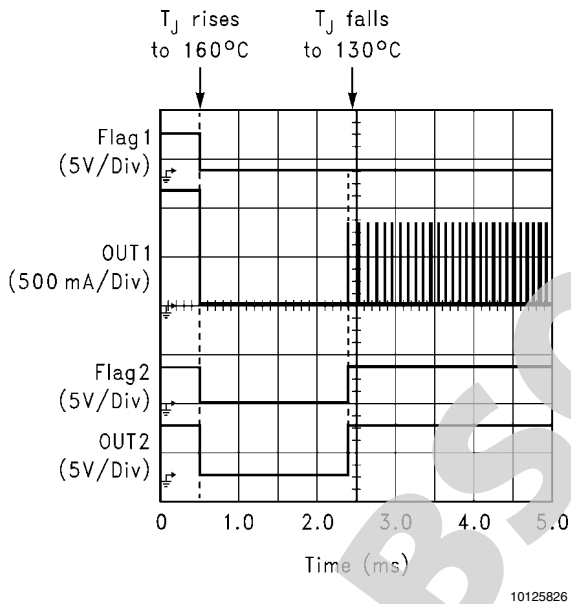

**FIGURE 4. Thermal Shutdown Characteristics when Both First-Stage and Second-Stage Thermal-Shutdown Modes are Needed**

In *Figure 3*, port 1 is enabled into a short. When this occurs, the MOSFET switch of port 1 repeatedly opens and closes as the device temperature rises and falls between 145°C and 135°C. In this example, the device temperature never rises above 160°C. The second stage thermal shutdown is not used and port 2 remains operational.

When port 1 is enabled into a short in the example illustrated in *Figure 4*, the device temperature immediately rises above 160°C. A higher ambient temperature or a larger number of shorted outputs can cause the junction temperature to increase, resulting in the difference in behavior between the current example and the previous one. When the junction temperature reaches 160°C, all three ports are disabled (port 3 is not shown in the figure) and all three fault-flag signals are asserted. Just prior to time index 2.5 ms, the device temperature falls below 135°C, all three ports activate, and all three fault flags are removed. The short condition remains on port 1, however. For the remainder of the example, the device

temperature cycles between 135°C and 145°C, causing port 1 to repeatedly turn on and off but allowing the un-shortened ports to function normally.

### SOFT START

When a power switch is enabled, high levels of current will flow instantaneously through the LM3543 to charge the large capacitance at the output of the port. This is likely to exceed the over-current threshold of the device, at which point the LM3543 will enter its current-limit mode. The amount of current used to charge the output capacitor is then set by the current-limit circuitry. The device will exit the current-limit mode when the current needed to continue to charge the output capacitor is less than the LM3543 current-limit level.

### FAULT FLAG

The fault flags are open-drain outputs, each capable of sinking up to a 10 mA load current to typically 100 mV above ground.

A parasitic diode exists between the flag pins and  $V_{IN}$  pins. Pulling the flag pins to voltages higher than  $V_{IN}$  will forward bias this diode and will cause an increase in supply current. This diode will also clamp the voltage on the flag pins to a diode drop above  $V_{IN}$ .

The fault flag is active (pulled low) when any of the following conditions are present: under-voltage, current-limit, or thermal-shutdown.

The LM3543 has an internal delay in reporting fault conditions that is typically 7 ms in length. In start-up, the delay gives the device time to charge the output capacitor(s) and exit the current-limit mode before a flag signal is set. This delay also prevents flag signal glitches from occurring when brief changes in operating conditions momentarily place the LM3543 into one of its three error conditions. If an error condition still exists after the delay interval has elapsed, the appropriate fault flag(s) will be asserted (pulled low) until the error condition is removed. In most applications, the 7 ms internal flag delay eliminates the need to extend the delay with an external RC delay network.

## Application Information

### OUTPUT FILTERING

The schematic in *Figure 1* showed a typical application circuit for the LM3543. The USB specification requires 120  $\mu\text{F}$  at the output of each hub. A three-port hub with 33  $\mu\text{F}$  tantalum capacitors at each port output meets the specification. These capacitors provide short-term transient current to drive downstream devices when hot-plug events occur. Capacitors with low equivalent-series-resistance should be used to lower the inrush current flow through the LM3543 during a hot-plug event.

The rapid change in currents seen during a hot plug event can generate electromagnetic interference (EMI). To reduce this effect, ferrite beads in series between the outputs of the LM3543 and the downstream USB port are recommended. Beads should also be placed between the ground node of the LM3543 and the ground nodes of connected downstream ports. In order to keep voltage drop across the beads to a minimum, wire with small DC resistance should be used through the ferrite beads. A 0.01  $\mu\text{F}$  - 0.1  $\mu\text{F}$  ceramic capacitor is recommended on each downstream port directly between the  $V_{BUS}$  and ground pins to further reduce EMI effects.

**POWER SUPPLY FILTERING**

A sizable capacitor should be connected to the input of the LM3543 to ensure the voltage drop on this node is less than 330 mV during a heavy-load hot-plug event. A 33  $\mu$ F, 16V tantalum capacitor is recommended. The input supply should be further bypassed with a 0.01  $\mu$ F - 0.1  $\mu$ F ceramic capacitor, placed close to the device. The ceramic capacitor reduces ringing on the supply that can occur when a short is present at the output of a port.

**EXTENDING THE FAULT FLAG DELAY**

While the 7 ms (typical) internal delay in reporting flag conditions is adequate for most applications, the delay can be extended by connecting external RC filters to the FLAG pins, as shown in *Figure 5*.

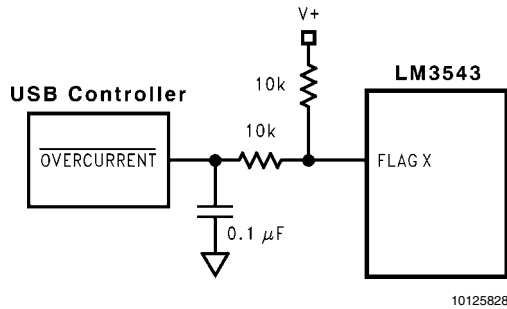

**FIGURE 5. Typical Circuit for Lengthening the Internal Flag Delay**

**POWER DISSIPATION AND JUNCTION TEMPERATURE**

A few simple calculations will allow a designer to calculate the approximate operating temperature of the LM3543 for a given application. The large currents possible through the low resistance power MOSFET combined with the high thermal resistance of the SOIC package, in relation to power packages, make this estimate an important design step. Begin the estimate by determining  $R_{ON}$  at the expected operating temperature using the graphs in the Typical Performance

Characteristics section of this datasheet. Next, calculate the power dissipation through the switch with *Equation 1*.

$$PD = R_{ON} * I_{DS}^2 \tag{1}$$

**Note:** Equation for power dissipation neglects portion that comes from LM3543 quiescent current because this value will almost always be insignificant.

Using this figure, determine the junction temperature with *Equation 2*.

$$T_J = PD * \theta_{JA} + T_A \tag{2}$$

Where:

$\theta_{JA}$  = SOIC Thermal Resistance: 130°C/W and  $T_A$  = Ambient Temperature (°C).

Compare the calculated temperature with the expected temperature used to estimate  $R_{ON}$ . If they do not reasonably match, re-estimate  $R_{ON}$  using a more appropriate operating temperature and repeat the calculations. Reiterate as necessary.

**PCB LAYOUT CONSIDERATIONS**

In order to meet the USB requirements for voltage drop, droop and EMI, each component used in this circuit must be evaluated for its contribution to the circuit performance. These principles are illustrated in *Figure 6*. The following PCB layout rules and guidelines are recommended

1. Place the switch as close to the USB connector as possible. Keep all  $V_{BUS}$  traces as short as possible and use at least 50-mil, 1 ounce copper for all  $V_{BUS}$  traces. Solder plating the traces will reduce the trace resistance.
2. Avoid vias as much as possible. If vias are used, use multiple vias in parallel and/or make them as large as possible.
3. Place the output capacitor and ferrite beads as close to the USB connector as possible.
4. If ferrite beads are used, use wires with minimum resistance and large solder pads to minimize connection resistance.

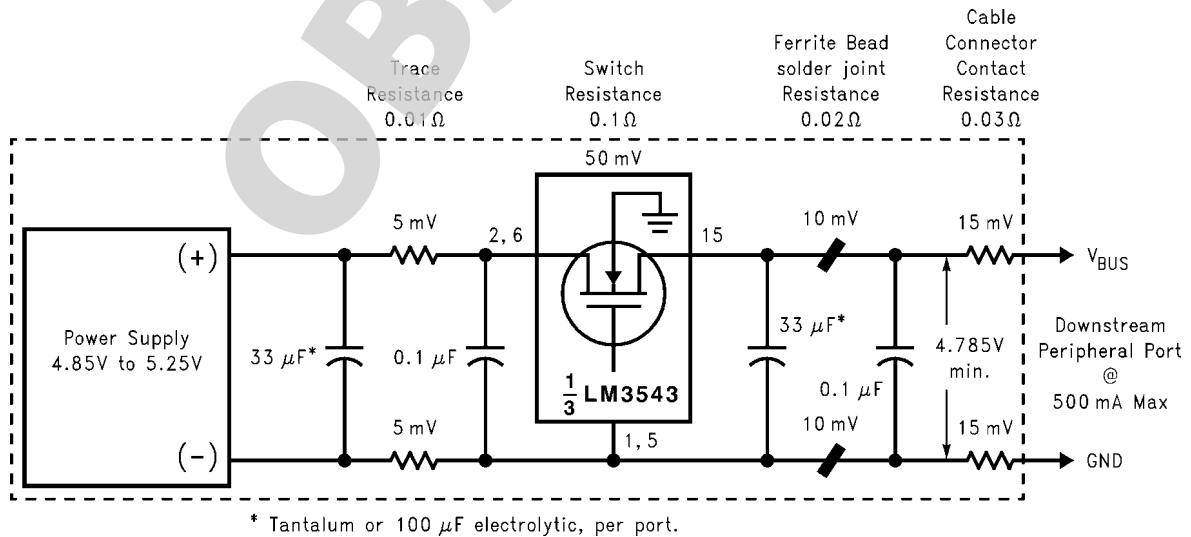

**FIGURE 6. Self-Powered Hub Connections and Per-Port Voltage Drop**

## Typical Applications

### ROOT AND SELF-POWERED USB HUBS

The LM3543 has been designed primarily for use in root and self-powered USB hubs. In this application, the switches of the LM3543 are used to connect the power source of the hub to the power bus used by downstream devices and to protect the hub from dangerously excessive loads and shorts to ground. A high-power bus-powered function, low-power bus-powered function, or a bus-powered hub can be driven through a single port of the LM3543. A schematic of a circuit that uses the LM3543 for power-supply switching in a typical root or self-powered hub was shown earlier in this datasheet in [Figure 1](#).

Voltage drop requirements of USB power supplies require the power outputs of the root and self-powered hubs to be no less than 4.75V. For this reason, it is recommended that a 5V power supply with a  $\pm 3\%$  output voltage tolerance is used in this application. Combining a 3% supply with a low-resistance PCB design and the low on-resistance of the LM3543 power switches will ensure that the hub power outputs meet the USB voltage drop specification even with a 500mA load, the maximum allowed in the USB standard.

### BUS-POWERED USB HUBS

The LM3543 is capable of performing the power supply switching functions required in Bus-Powered hubs. Use here is very similar to the configuration used in root and self-powered hubs. With bus-powered hubs, however, there is no internal power supply to drive the input pins of the LM3543.

Instead, the input pins should be connected to the power bus supplied by the upstream hub.

### USB BUS-POWERED FUNCTIONS AND GENERAL IN-RUSH CURRENT LIMITING APPLICATIONS

The LM3543 can be placed at the power-supply input of USB bus-powered functions, or other similar devices, to protect them from high in-rush currents. If the current being delivered to the device were to exceed the 2.0A over-current threshold (typ.) of the LM3543, switches in violation would open to protect the device from damage.

In addition to in-rush current limiting, the LM3543 can be used in high-power bus-powered functions to keep current levels of the function in compliance during power-up. The USB specification requires the staged switching of power when connecting high-power functions to the bus. When a high-power function is initially connected to the bus, it must not draw more than one unit supply (100mA). After a connection is detected and enumerated, and if the upstream device is capable of supplying the required power, the high-power function may draw up to five unit loads (500mA). With the proper control signals, the LM3543 can be used to achieve this staged power connection. When the function is connected to the bus, one or more of the LM3543 switches can be closed to connect bus power only to circuitry needed during the connection and enumeration process. If the function is to be powered fully, remaining switches on the LM3543 can be closed to connect all blocks of the function to the power bus. [Figure 7](#) illustrates how the LM3543 can be connected for use in bus powered functions.

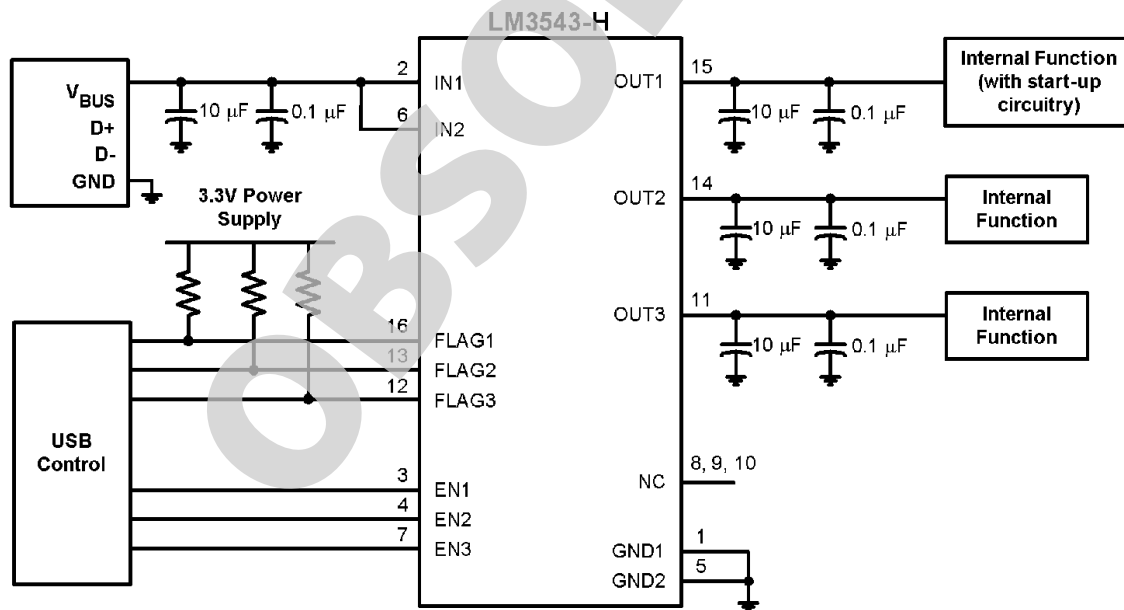

10125831

FIGURE 7. Using the LM3543 in USB Bus-Powered Functions

**Physical Dimensions** inches (millimeters) unless otherwise noted

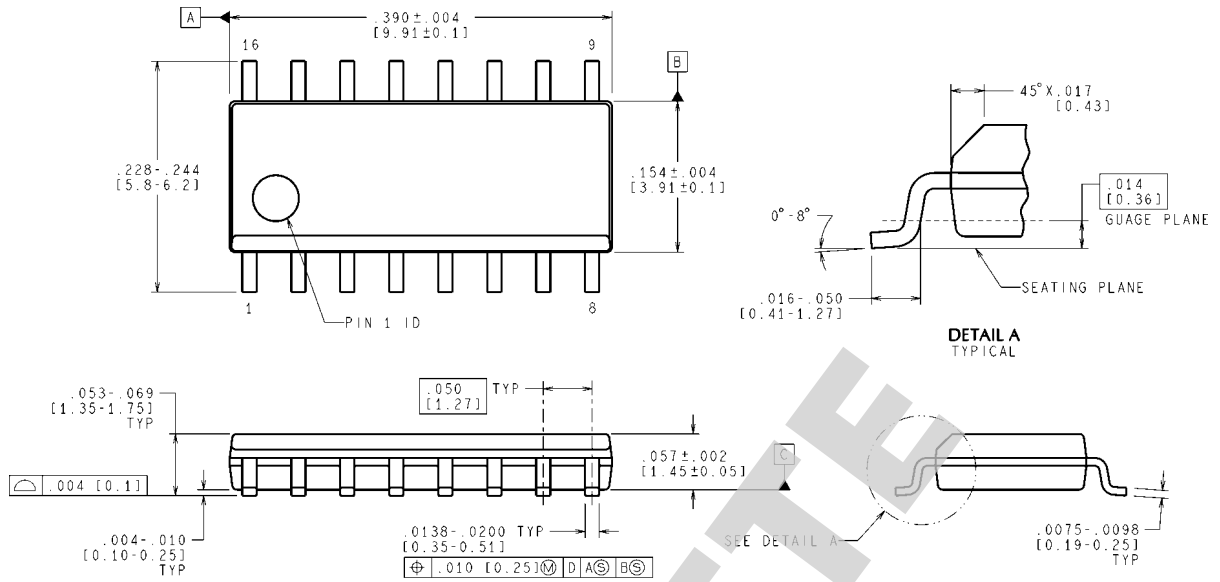

CONTROLLING DIMENSION IS INCH  
VALUES IN [ ] ARE MILLIMETERS

Order Number LM3543M-H, LM3543M-L, LM3543MX-H or LM3543MX-L  
NS Package Number M16A

M16A (Rev J)

## Notes

LM3543

**OBSOLETE**

## Notes

For more National Semiconductor product information and proven design tools, visit the following Web sites at:  
[www.national.com](http://www.national.com)

Products		Design Support	
Amplifiers	<a href="http://www.national.com/amplifiers">www.national.com/amplifiers</a>	WEBENCH® Tools	<a href="http://www.national.com/webench">www.national.com/webench</a>
Audio	<a href="http://www.national.com/audio">www.national.com/audio</a>	App Notes	<a href="http://www.national.com/appnotes">www.national.com/appnotes</a>
Clock and Timing	<a href="http://www.national.com/timing">www.national.com/timing</a>	Reference Designs	<a href="http://www.national.com/refdesigns">www.national.com/refdesigns</a>
Data Converters	<a href="http://www.national.com/adc">www.national.com/adc</a>	Samples	<a href="http://www.national.com/samples">www.national.com/samples</a>
Interface	<a href="http://www.national.com/interface">www.national.com/interface</a>	Eval Boards	<a href="http://www.national.com/evalboards">www.national.com/evalboards</a>
LVDS	<a href="http://www.national.com/lvds">www.national.com/lvds</a>	Packaging	<a href="http://www.national.com/packaging">www.national.com/packaging</a>
Power Management	<a href="http://www.national.com/power">www.national.com/power</a>	Green Compliance	<a href="http://www.national.com/quality/green">www.national.com/quality/green</a>
Switching Regulators	<a href="http://www.national.com/switchers">www.national.com/switchers</a>	Distributors	<a href="http://www.national.com/contacts">www.national.com/contacts</a>
LDOs	<a href="http://www.national.com/ldo">www.national.com/ldo</a>	Quality and Reliability	<a href="http://www.national.com/quality">www.national.com/quality</a>
LED Lighting	<a href="http://www.national.com/led">www.national.com/led</a>	Feedback/Support	<a href="http://www.national.com/feedback">www.national.com/feedback</a>
Voltage References	<a href="http://www.national.com/vref">www.national.com/vref</a>	Design Made Easy	<a href="http://www.national.com/easy">www.national.com/easy</a>
PowerWise® Solutions	<a href="http://www.national.com/powerwise">www.national.com/powerwise</a>	Applications & Markets	<a href="http://www.national.com/solutions">www.national.com/solutions</a>
Serial Digital Interface (SDI)	<a href="http://www.national.com/sdi">www.national.com/sdi</a>	Mil/Aero	<a href="http://www.national.com/milaero">www.national.com/milaero</a>
Temperature Sensors	<a href="http://www.national.com/tempensors">www.national.com/tempensors</a>	SolarMagic™	<a href="http://www.national.com/solarmagic">www.national.com/solarmagic</a>
PLL/VCO	<a href="http://www.national.com/wireless">www.national.com/wireless</a>	PowerWise® Design University	<a href="http://www.national.com/training">www.national.com/training</a>

THE CONTENTS OF THIS DOCUMENT ARE PROVIDED IN CONNECTION WITH NATIONAL SEMICONDUCTOR CORPORATION ("NATIONAL") PRODUCTS. NATIONAL MAKES NO REPRESENTATIONS OR WARRANTIES WITH RESPECT TO THE ACCURACY OR COMPLETENESS OF THE CONTENTS OF THIS PUBLICATION AND RESERVES THE RIGHT TO MAKE CHANGES TO SPECIFICATIONS AND PRODUCT DESCRIPTIONS AT ANY TIME WITHOUT NOTICE. NO LICENSE, WHETHER EXPRESS, IMPLIED, ARISING BY ESTOPPEL OR OTHERWISE, TO ANY INTELLECTUAL PROPERTY RIGHTS IS GRANTED BY THIS DOCUMENT.

TESTING AND OTHER QUALITY CONTROLS ARE USED TO THE EXTENT NATIONAL DEEMS NECESSARY TO SUPPORT NATIONAL'S PRODUCT WARRANTY. EXCEPT WHERE MANDATED BY GOVERNMENT REQUIREMENTS, TESTING OF ALL PARAMETERS OF EACH PRODUCT IS NOT NECESSARILY PERFORMED. NATIONAL ASSUMES NO LIABILITY FOR APPLICATIONS ASSISTANCE OR BUYER PRODUCT DESIGN. BUYERS ARE RESPONSIBLE FOR THEIR PRODUCTS AND APPLICATIONS USING NATIONAL COMPONENTS. PRIOR TO USING OR DISTRIBUTING ANY PRODUCTS THAT INCLUDE NATIONAL COMPONENTS, BUYERS SHOULD PROVIDE ADEQUATE DESIGN, TESTING AND OPERATING SAFEGUARDS.

EXCEPT AS PROVIDED IN NATIONAL'S TERMS AND CONDITIONS OF SALE FOR SUCH PRODUCTS, NATIONAL ASSUMES NO LIABILITY WHATSOEVER, AND NATIONAL DISCLAIMS ANY EXPRESS OR IMPLIED WARRANTY RELATING TO THE SALE AND/OR USE OF NATIONAL PRODUCTS INCLUDING LIABILITY OR WARRANTIES RELATING TO FITNESS FOR A PARTICULAR PURPOSE, MERCHANTABILITY, OR INFRINGEMENT OF ANY PATENT, COPYRIGHT OR OTHER INTELLECTUAL PROPERTY RIGHT.

#### LIFE SUPPORT POLICY

**NATIONAL'S PRODUCTS ARE NOT AUTHORIZED FOR USE AS CRITICAL COMPONENTS IN LIFE SUPPORT DEVICES OR SYSTEMS WITHOUT THE EXPRESS PRIOR WRITTEN APPROVAL OF THE CHIEF EXECUTIVE OFFICER AND GENERAL COUNSEL OF NATIONAL SEMICONDUCTOR CORPORATION.** As used herein:

Life support devices or systems are devices which (a) are intended for surgical implant into the body, or (b) support or sustain life and whose failure to perform when properly used in accordance with instructions for use provided in the labeling can be reasonably expected to result in a significant injury to the user. A critical component is any component in a life support device or system whose failure to perform can be reasonably expected to cause the failure of the life support device or system or to affect its safety or effectiveness.

National Semiconductor and the National Semiconductor logo are registered trademarks of National Semiconductor Corporation. All other brand or product names may be trademarks or registered trademarks of their respective holders.

Copyright© 2010 National Semiconductor Corporation

For the most current product information visit us at [www.national.com](http://www.national.com)

  
**National Semiconductor**  
**Americas Technical**  
**Support Center**  
 Email: [support@nsc.com](mailto:support@nsc.com)  
 Tel: 1-800-272-9959

**National Semiconductor Europe**  
**Technical Support Center**  
 Email: [europe.support@nsc.com](mailto:europe.support@nsc.com)

**National Semiconductor Asia**  
**Pacific Technical Support Center**  
 Email: [ap.support@nsc.com](mailto:ap.support@nsc.com)

**National Semiconductor Japan**  
**Technical Support Center**  
 Email: [jpn.feedback@nsc.com](mailto:jpn.feedback@nsc.com)